

Experimental study of cathodic protection for reinforced concrete submerged in saline water

H. Oleiwi^{1,4}, *Y.Wang¹, M. Curioni², L. Augustus-Nelson¹, X. Chen³, I. Shabalin¹

1. School of Computing, Science & Engineering, University of Salford, Manchester M5 4WT, UK

2. Corrosion and Protection Centre, University of Manchester, Manchester M13 9PL, UK

3. Charter Coating Service (2000) Ltd, Calgary AB T2E 6P1, Canada

4. College of Engineering, University of Thi-Qar, Nasiriyah, Iraq

**Corresponding Author: y.wang@salford.ac.uk*

Abstract

Cathodic protection (CP) has been approved in practice to be an effective technique to protect steel reinforcement in concrete from corrosion under severe environmental conditions. Using constant current for CP is the most popular approach in practice, particularly for the structures exposed to atmospheric conditions. However, for submerged structures, the situation of the reinforcement is quite different, if the constant current approach is efficient to provide adequate protection is still not very clear. To have a deep understanding for the question, an experimental investigation has been conducted for reinforced concrete specimens protected by impressed electrical current of both constant current density and constant potentiostatically controlled potential, respectively. Reinforced concrete specimens had varied chloride contents and submerged into salty solutions that have the same amount of chloride added in the concrete mixture have been examined. The performance of protection has been evaluated and discussed. Corrosion potentials and concrete resistivity were also measured and compared with those of chloride content/corrosion rate.

Keywords: “Corrosion potential; corrosion rate; design criteria; impressed cathodic protection; reinforced concrete”

Introduction

Steel in concrete is in a passive state, safe from corrosion, due to high alkalinity of concrete typically of pH 12.5-13.5. A very thin protective films formed on the steel surface which prevent the steel from corrosion [1].

According to Pithouse [2], the highly alkalinity of concrete mainly comes from calcium hydroxide which is a result of the hydration of cement compounds (namely C3S and C2S) as explained below:

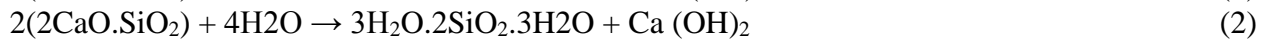
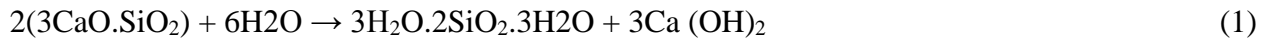

However, despite the high protective ability of concrete, corrosion of steel reinforcement is becoming the most common cause of the deterioration of concrete structures due to the chloride ability to depassivate the steel in concrete [3]. Coastal and offshore structures, sewers, structures in aggressive soils, bridge decks and other structures subjected to chloride contaminated water are some examples where severe corrosion attack occurs [4].

It is very crucial to protect reinforcing steel from corrosion in order to extend the durability and increase the service life of reinforced concrete structures [5]. Different chemical, mechanical and electrochemical methods are adopted to protect or prevent concrete structures from corrosion [5, 6]. Most of the non-electrochemical repair techniques are not very effective in reducing the corrosion rate, since they may arrest the problem with little or no success [7].

Among the various corrosion control methods available, cathodic protection (CP) is an electrochemical and a major repair technique that has increasingly been used for the maintenance of corrosion damaged reinforced concrete structures around the world [8-10].

CP can be applied using either sacrificial anodes or impressed current systems. Sacrificial anodes are preferred to be adopted where the electrolyte conductivity is relatively high like buried and submerged concrete structures. But the voltage difference between the anode and the protected steel is limited to a maximum of 1V. In addition, it is less adjustable after installation and protective current is controlled by the environment around the structure [11]. Impressed current CP is usually the most appropriate technique to stop corrosion in different severe circumstances like structures with high concrete resistivity, and high chloride presented in the environment of the structures due to the high voltage, reached to 100V, that can be generated by this system between the anode and the cathode [11].

The two major criteria to control the performance of cathodic protection are the potential of the steel (Instant-off potential) and potential decay (depolarization) [12, 13]. The development of these criteria is still based on empirical evaluation of data obtained from successfully operated CP [14].

BS EN ISO 12696:2012 [15] specified that the Instant-off potential should be more negative than -720 mV Ag/AgCl/0.5KCl for any structure under CP. While more negative potentials of -850 mV with respect to copper sulphate electrode (CSE) (\approx -800 mV vs Ag/AgCl/0.5KCl) has been suggested by NASE SP0408 standard as criteria for the protected reinforcing steel in submerged concrete structures [14]. The BS [15] stated that to avoid hydrogen evolution at the steel surface,

the potential (instant-off) should be kept at a low limit value of -1100 mV Ag/AgCl/0.5KCl for normal reinforcing steel and -900 mV with respect to Ag/AgCl/0.5KCl for high strength steel reinforcement which is used for pre-stressed structures.

The other most widely adopted performance criteria based on potential decay is the 100-mV depolarization criterion. In order to ensure that the protection is achieved and overprotection is avoided, and more generally to determine the performance of the CP system, potential of reinforcement should decay (become less negative) by at least 100 mV from the instant-off potential over a period between 4 and 24 hours after the CP system is switched off [14-16].

The amount of required current to achieve cathodic protection must be enough to lower the potential of the reinforcing steel towards the immunity zone, and electrochemical attack cannot occur, so that all the reinforcement become cathodic and corrosion will be stopped [17].

The amount of current or potential difference between anode or cathode is the vital factor that needs to be designed to provide protection for the corroded reinforcement and to ensure that the anode has the ability to supply a current across the affected structure at a reasonable DC output voltage [18]. The current density required to maintain a metal surface cathodically protected must be not only high enough but also low enough to reduce the adverse effects on the anode to increase its life. The current density varies from 1-2 mA/m² of total surface area of the protected steel, applied to new structures, to 5-20 mA/m², applied to structures that already suffered from corrosion [3].

The present research work was designed to provide new information and to achieve a better understanding on the influence of the surrounding environment on the behaviour of the reinforcement embedded in submerged concrete specimens, and to evaluate the CP which has been applied using constant values of both current and potential. Corrosion potentials and resistivity results were compared with those of chloride content/corrosion rate. The design criteria has also been evaluated.

Material and Specimens

Reinforced concrete specimens of 150x90x93 mm illustrated in Figure 1 were prepared in the lab to perform electrochemical measurements for submerged concrete specimens. Three reinforcing bars of 10 mm in diameter were embedded in each concrete specimen with an exposed total area of 6880 mm². A layer of carbon fibre (CF) sheet was embedded in each specimen to represent the anode with an area of 13392 mm².

Concrete cubes of size of 100mm x 100mm x 70mm were also made and cured following the same procedure as that used for the cathodic protection test. Each of the concrete cubes had two embedded electrodes of carbon fibre fabric for resistivity measurement. More details about preparing the specimens for CP and resistivity tests are available elsewhere [19].

The concrete specimens were made with 390 kg/m³ of cement and water to cement ratio of 0.4. Table 1 presents the quantities and properties of the ingredient of concrete used to give compressive strength of 35 MPa at 28 days under wet exposure conditions.



(A) The casted reinforced specimen

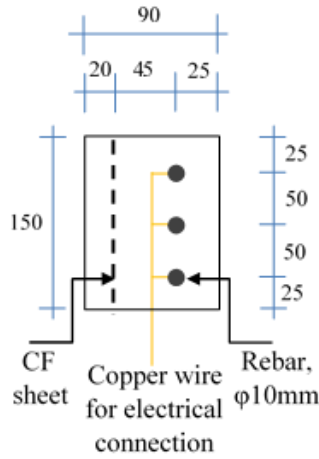

(B) Top view

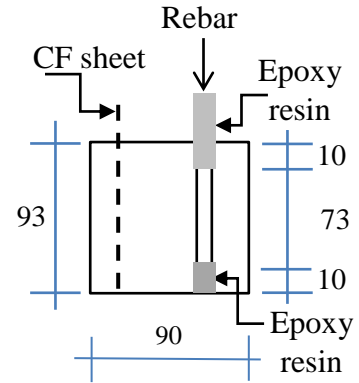

(C) Front view

Figure 1: Details of CP specimen, all dimensions are in mm

Different concentrations of chloride as pure NaCl of 1, 2, 3.5 and 5% of the cement mass, respectively, were added into the mix water at the time of concrete casting. Two specimens were made for the cathodic protection test and three specimens for the electrical concrete resistivity for each single chloride content.

All the specimens were cured for 28 days in solutions that have the same percentage of NaCl that specimens have (i.e., samples that mixed with 2%NaCl were immersed in a solution of 2% NaCl by weight of curing water).

Table 1: Quantities of used materials

Properties of materials	Quantity Kg/m ²
Portland cement with limestone CEM II/A-LL	390
Limestone coarse aggregates 10 mm maximum size, relative density of 2.49	580
Fine aggregates, 4.75mm maximum size, relative density of 2.47	1125
Water	156

Electrochemical Measurements

Corrosion Potential, Corrosion Rate and Electrical Concrete Resistivity

ASTM C876-2015 was followed to measure the corrosion potential of the rebars as shown in Figures 2 using a silver/silver chloride (Ag/AgCl/0.5M KCl) reference electrode and high impedance digital voltmeter. All the concrete specimens were immersed in salty water for two weeks before implement of the electrochemical measurements of this work. The concentration of the NaCl in curing water used was exactly the same amount that has already added to the mixing water during making the concrete, so that the chlorides do not depart the body of the concrete.

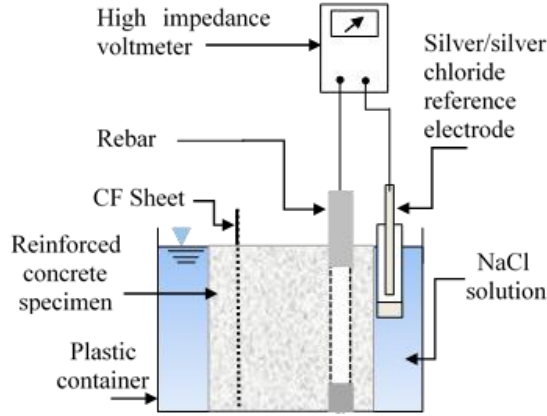

Figure 2: Schematic drawing for testing corrosion potential

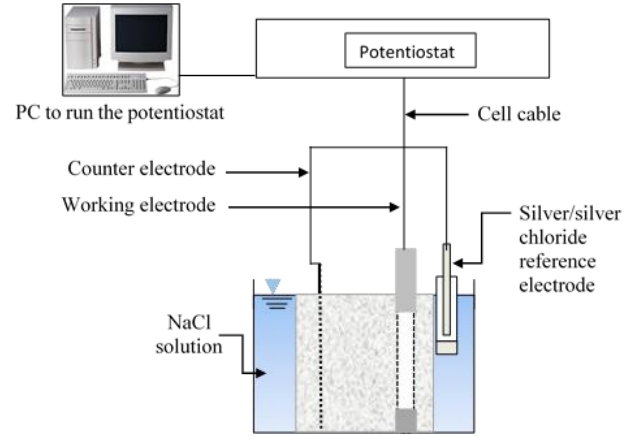

Figure 3: Experimental scheme of polarization resistance test

Linear polarization method described by [20] was performed before performing CP test. A potential shift to the open circuit potential of rebars of the maximum 20 mV for cathodic and 20 mV for anodic [21, 22] were applied at a scan rate of 0.125 mV/s, using a computer controlled Gamry potentiostat. A three-electrode technique was used to set the potential of the reinforcing bars as shown in Figure 3. The ohmic drop between the working and the reference electrode is auto compensated.

Polarization resistance, R_p , then was determined as the slop of the plot, at zero current, between the applied voltage and the measured current. The R_p at zero current on the potential versus current graph obtained from the experiment was considered for all specimens for comparison [23]. The corrosion rate is then determined using the Stern-Geary equation as below.

$$I_{corr} = \frac{B}{R_p} \quad (3)$$

Where,

B: a constant in mV which equals to $(\beta_a \cdot \beta_c / 2.3 (\beta_a + \beta_c))$

β_a and β_c are the anodic and cathodic Tafel constants

R_p : the polarization resistance in Ω ($\Delta E / \Delta I$)

I_{corr} : is the corrosion rate in mA

A value of 26 mV has been used for the constant B for steel that is actively corroded in concrete [9, 24]. I_{corr} is related to the area of the rebar under test. From the measured I_{corr} value, the corrosion current density, i_{corr} , expressed in mA/m², was determined from the relationship below [25], where A was the surface area of the rebar.

$$i_{corr} = \frac{I_{corr}}{A} \quad (4)$$

Two-electrode technique has been used for the resistivity measurement and more details are available in reference [19].

Cathodic Protection Test

Galvanostatic polarization technique were used to apply three different levels of constant current densities using Gamry potentiostat 1000E to produce a cathodic polarization at the rebars of the specimens. These levels were chosen depends on the obtained results of corroion rates of each chloride group, and they should be equal or less than the measured corrosion rate. The set up of the expriment used is illustrated in Figure 4. The rebars were connected to the working electrode of the potentiostat whereas the anode was connected to the counter electrode. The reference electrode was partially submerged in the solution and connected to the reference electrode terminal of the potentiostat. Each level of CP current was applied for 5 days and the potential of rebars was recorded during the operation using data logger. After the day 5 of operation, the sysetem was switched-off and the depolarazation was monitored using data logger for 24 hours to evaluate the performace of CP. Instant off potential was measured at 1 minutes after the CP was switched off.

The potential difference between the instant-off potential and the potential measured at 4 and 24 hours after switching off the CP current were also measured to be used to evaluate the efficiency of PC protection [26, 27].

A CP technique using constant potential controlled potentiostatically was also applied for comparison with the application of constant current technique in order to highlight the most convenient technique than can be used in practice. The potential of the reinforcement was polarized to -800 mV with respect to Ag/AgCl/0.5KCl reference electrode. This level represents the recommended potential for the normal protection in practice. The test was operated for 5 days and then switched-off for 24 hrs. The variation of the passing current was recorded during the operation, and the potential variation after switching off the system was also monitored using data logger to evaluate the technique for protection.

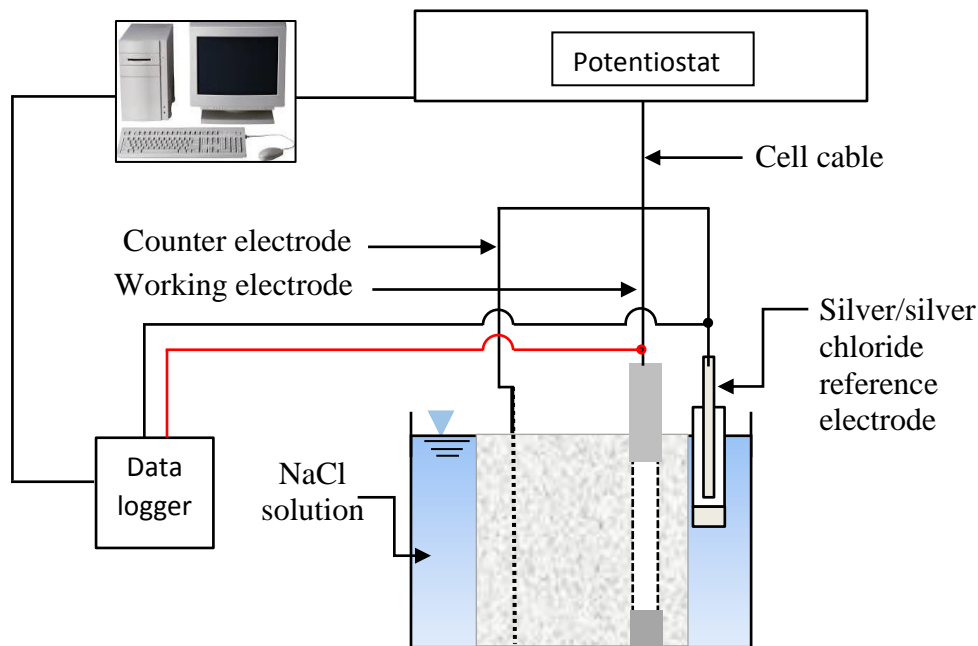

Figure 4: Scheme of CP experimental arrangement

Results and Discussion

Corrosion Potential, Corrosion Rate and Electrical Resistivity

Figure 5 shows a plot of corrosion potential of reinforcement against chloride content added to concrete specimens as NaCl. It can be seen there was no clear correlation, and changing the amount of NaCl did not show a noticeable difference in potential readings, but an increase in corrosion potential was observed for all specimens. All the specimens show values of potential more negative than -300 mV vs Ag/AgCl 0.5KCl (-350 vs CSE), indicative of a high risk of corrosion and there is probability of 90% to corrode according to the ASTM standard C876. Severe corrosion can be noticed is due to the existence of chloride (NaCl) in concrete specimens that breakdown the passive layer of rebars.

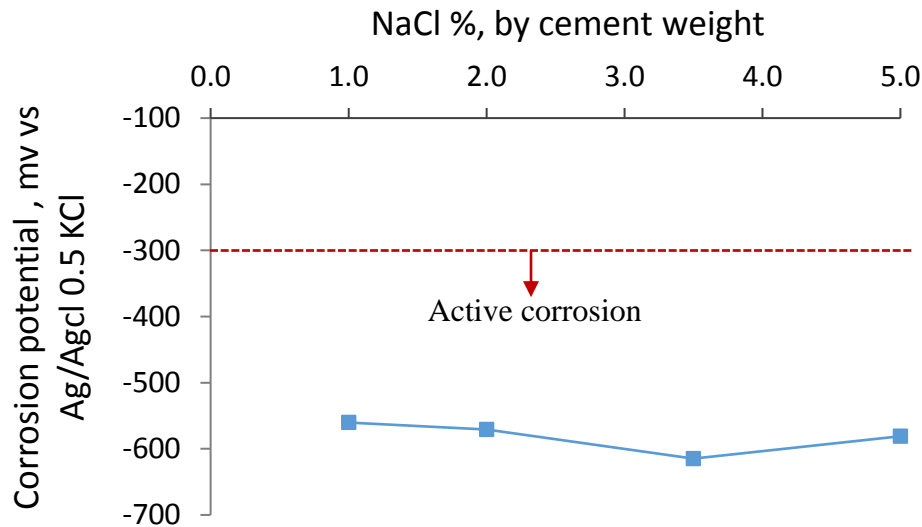

Figure 5: Corrosion potential of steel in saturated concrete with chloride concentration

Very negative potentials in saturated concrete may not be applicable to ASTM standard C876 because more negative potential values with no signs of corrosion could be attributed to the limited amount of the oxygen presence in water saturated structures, and the increase in corrosion potential may not necessarily be associated with an increase in corrosion, but could reflect a limited availability of oxygen at the steel/concrete interface [12]. However, highly water saturated structures can corrode rapidly without signs of the corrosion process occurring [28] and significant corrosion can be developed

It could be lead to conclude that corrosion potential can be used to indicate a probability of corrosion and provide a general sense but not to be used as a stand-alone technique. Other measurements such as corrosion rate, concrete resistivity and chloride analysis could be required for more information in such ambiguous conditions.

Figure 6 shows the corrosion rates worked out on the obtained R_p at different chloride concentration. It is evident that corrosion rate increases when chloride content increases in specimens. The corrosion current density was 41, 75.5, 110.1 and 142.2 mA/m² for the specimens of 1%, 2%, 3.5% and 5 % NaCl, respectively. Increased chloride content from 1% to 5% NaCl

caused increase in corrosion rate by two times and a half. Unlike corrosion potential, corrosion rate presents a very good correlation with the chloride content.

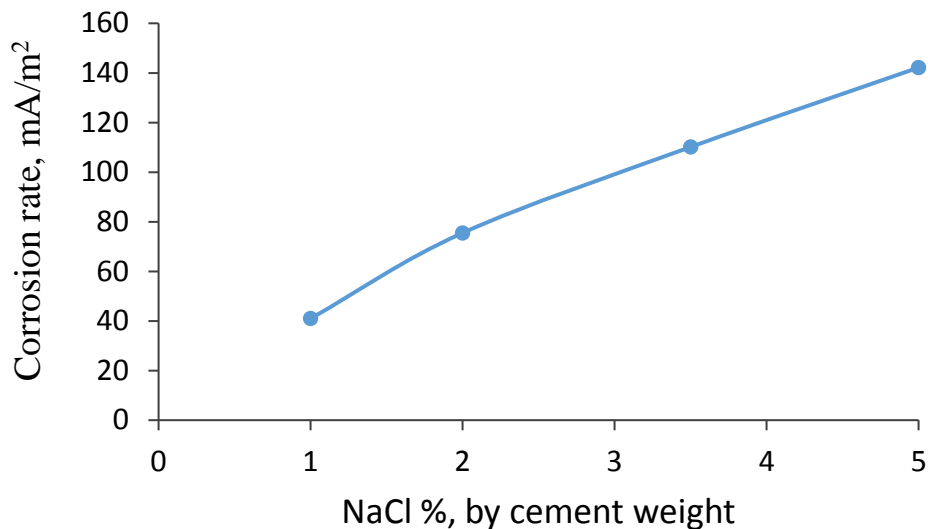

Figure 6: Influence of chloride concentration on steel corrosion rate in concrete

Broomfield [28] proposed that the corrosion rate is considered to be high when corrosion current density is greater than 10 mA/m². In terms of this classification, all the specimens fell within the high corrosion severity zone. In fact, the values of the corrosion rate obtained are much higher than that expected, because corrosion rate under saturated states is assumed to be low due to oxygen availability limited by slow transportation in water [29, 30]. The obtained results confirm what stated by Broomfield [28] which said that significant corrosion can be developed in concrete structures with high moisture content.

Similar as corrosion potential and corrosion rate, electrical resistivity of concrete is also a very important parameter determining the risk of corrosion of rebars, which should be considered in the design of cathodic protection system. Figure 7 presents the resistivity of concrete at varied chloride contents under saturated state. It shows that concrete resistivity decreases with chloride content. A correlation between corrosion rate and resistivity values of concrete is presented in Figure 8, which shows severity of corrosion increased as concrete resistivity decreased.

An earlier study [31] concluded that very high corrosion occurs when resistivity is less than 10000 Ω.cm. Another study by [32] showed a very high probability of reinforcement corrosion in concrete of the resistivity lower than 5000 Ω.cm. The finding of this work was almost similar to previous research as high corrosion rates, in the range of (40 to 140) mA/m², has been measured for the specimens with various chloride content, and all the resistivity values were less than 4000 Ω.cm. It can be concluded that all specimens with different chlorides were active to corrode.

Based on above, measurements of chloride content, concrete resistivity and reinforcement corrosion rate are highly recommended in order to evaluate the activity of corrosion in concrete structures submerged in salty water.

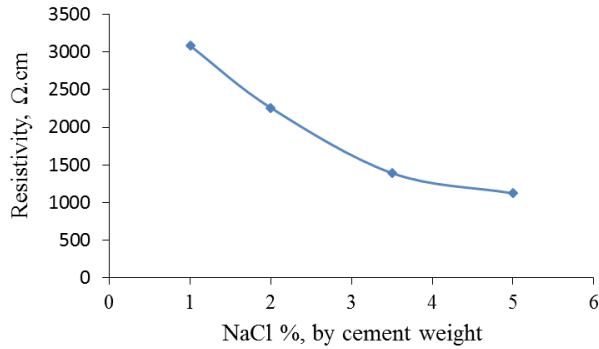

Figure 7: Dependence of resistivity of concrete on chloride content

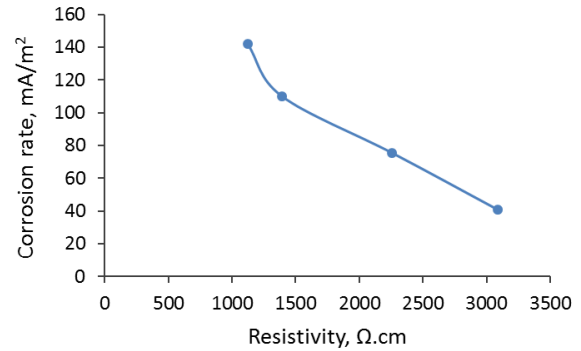

Figure 8: The relationship between the resistivity of concrete and the corrosion rate

Constant Current Technique

Figure 9 shows the shifted rebar potential during the application of different levels of CP currents for 5 days, and the depolarization for 24 hours. It can clearly be noted that the measured potential decreases with the activation period. Also, it clearly shows that the longer the operating time the higher the potential in the negative direction. For example, in the case of 1% NaCl specimens, the polarization of rebars was 82mV and 164mV after 1 day and 5 days of operation respectively when current density of 5 mA/m² was applied. In addition, the rate of potential shift in time (the slope of these curves) is proportional to the density of the applied current. For instance, the polarization in the case of 1% NaCl specimens increased from 164mV to 276mV when 5 and 20 mA/m² were applied for 5 days respectively, and this means that the potential shift is proportional with the passing current.

This trend has been noticed for all other chloride contents and applied levels of currents, as shown in Figures, and does not tend to stabilize during the 5 days of operation period. This is likely lead to overprotection and causing hydrogen evolution at the reinforcement surface. BS criteria specified that instant-off potential more negative than -720 mV vs Ag/AgCl/0.5 M KCl is sufficient to provide adequate CP for submerged structures and no instant-off potential should exceed a limit of -1100 mV with respect to Ag/AgCl/0.5 M KCl for reinforced concrete.

A depolarization test was also conducted after CP has been interrupted and the potential was allowed to decay for 24 hours as shown in Figure 9. The characterisation of potential decay is considering as one of the major consideration for the evaluation of protection efficiency. It can be seen that the potential moves at very slow rate towards the original potential before applying CP. Also, the 4 hours and 24 hours decay was in all cases less than 100 mV.

In terms of 100 mV depolarisation criterion, 4 or 24 hours does work for concrete structures exposed to high moisture where the oxygen availability is low. Longer periods for the depolarization may be required for CP evaluation.

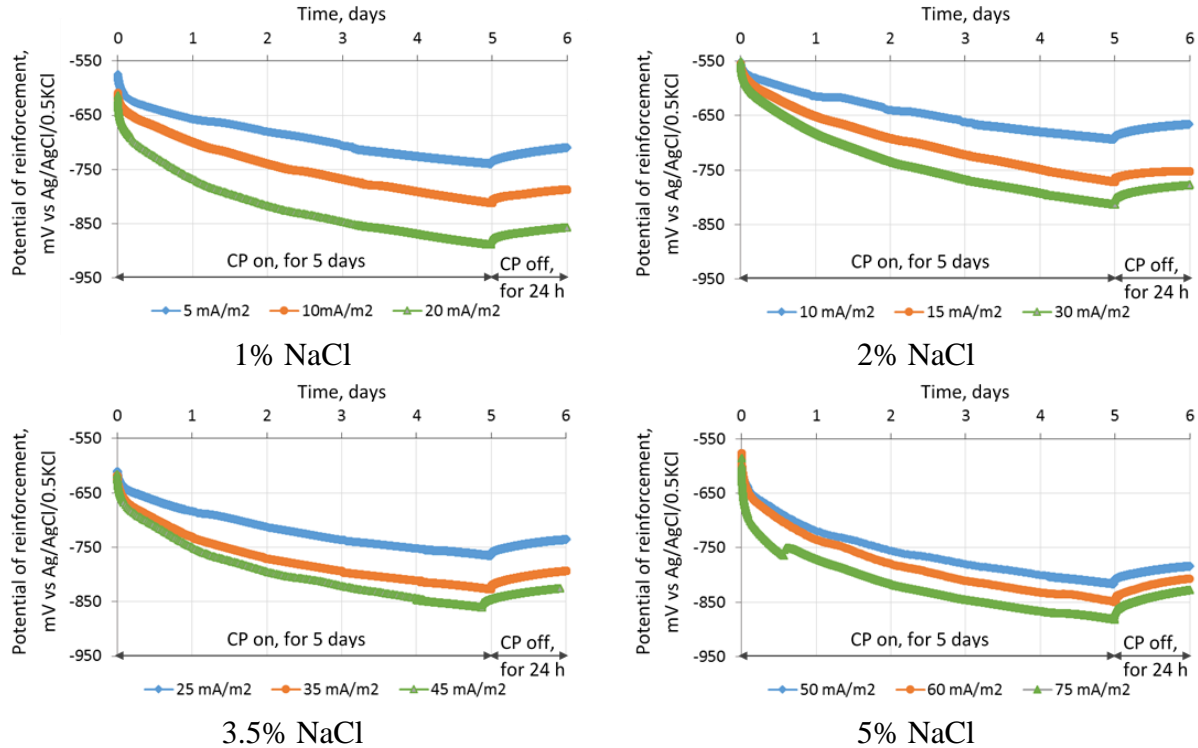

Figure 9: Potential variation with time for specimens submerged in solutions with different NaCl concentration at various applied CP current densities, and the corresponding potential decay curves.

Constant Potential Technique

In order to be away from overprotection that constant current technique may cause, a constant potential mode could be a good choice in such submerged concrete elements. In this technique, the potential of rebars was forced to be at a consistent protection level of -800 mV vs Ag/AgCl/0.5KCl (\approx -850 vs CSE) during an activation period of 2 to 5 days using potentiostatically controlled potential technique. Due to the limited time, only the specimens of 2, 3.5 and 5% NaCl were examined for this test. The variation of passing current has been monitored and presented in Figure 10. The passing current for the potential demand of protection is another way of expressing the current required to produce the specified potential. It is evident that the current decreases with time. The rate of decreasing was noticeably high at early stage of operation. After that, it was gradually decreased until tend to stabilized after about 2 days of operation to a value of tens of milliamperere per square metre. All the specimens with different chloride contents show the same behaviour. However, the results showed that passing current which reflect the current demand to provide the required potential increases with chloride content. For instance, the flowing currents were 116, 201 and 296 μ A (17, 29 and 43 mA/m²) after 2 days of operation for the specimens of 2, 3.5 and 5% NaCl respectively.

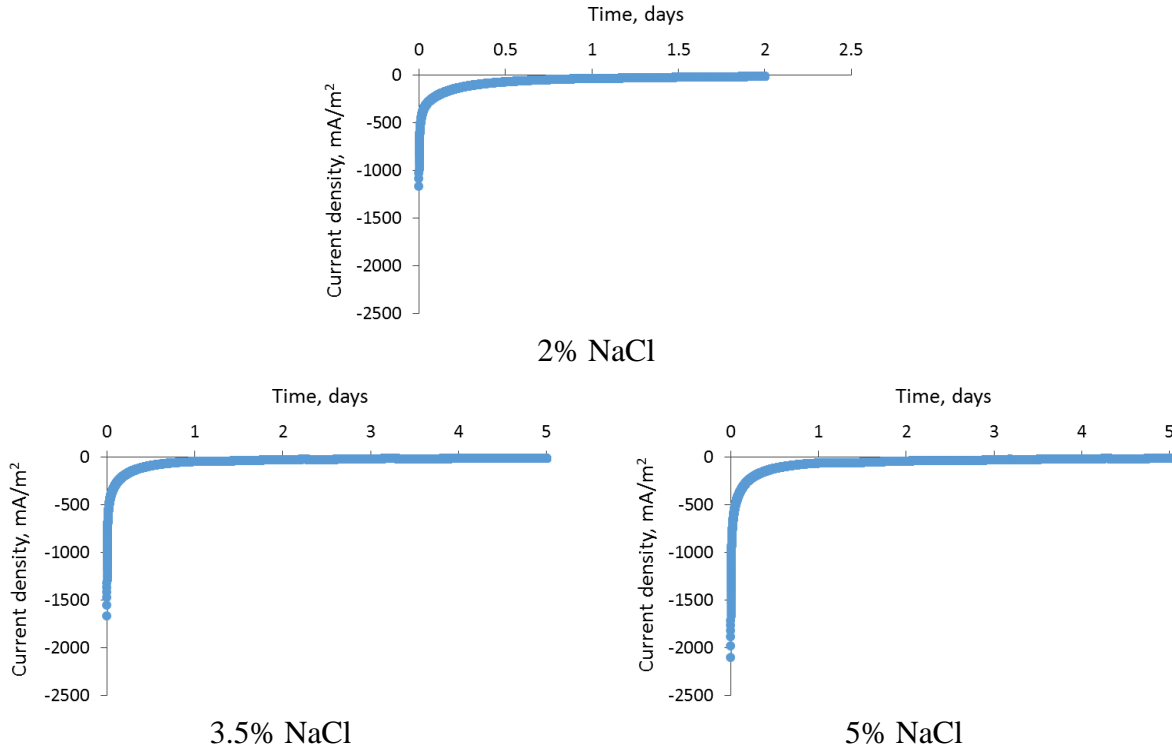

Figure 10: Variation of flowing current with time for the potential demand of CP for specimens immersed in solutions with various concentration of NaCl

Similar observations in which the initial current density is higher by several times of magnitude than the stabilised current density has been reported [12]. This was attributed to the re-alkalisation and chloride removal at the steel/concrete interface, and possibly resulting in an increase in the steel surface polarisation resistance.

A depolarization test, as shown in Figure 11, was also performed after CP has been stopped and the potential decay was recorded for 24 hours using data logger to evaluate the effectiveness of the protection based on 100 mV depolarization criteria recommended by standards [15]. Same result has been recorded for those obtained using constant current technique, all the potentials at 4 and 24 hours were in the range of (5-10) mV and (10-20) mV respectively, and it is obvious less than the value stated in standards for efficiency of protection. It is worth noting that the instant off potential is approximately the same of the on potential.

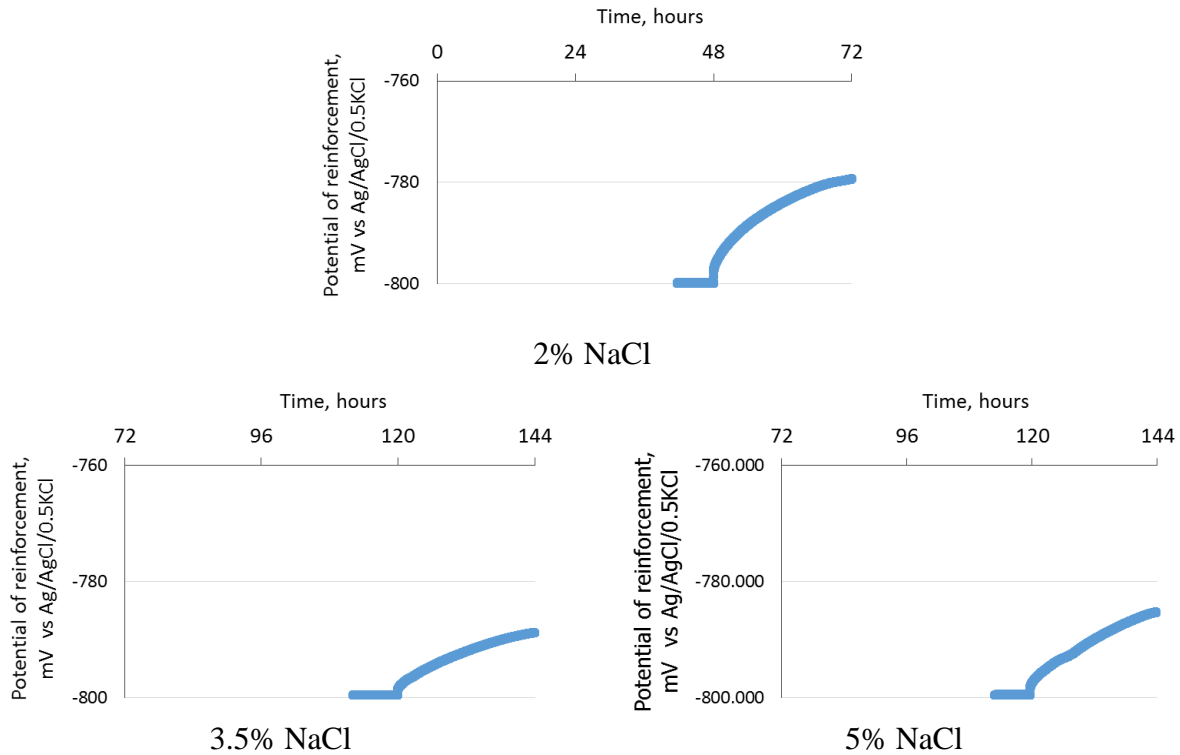

Figure 11: Potential decay with time for specimens submerged in solutions with various concentration of NaCl

Conclusion

Based on the obtained results for the submerged concrete specimens in salty solutions, the following conclusion can be drawn:

1. In terms of 100 mV depolarisation criterion, 4 or 24 hours does work for concrete structures exposed to high moisture where the oxygen availability is low. Longer periods for the depolarization may be required for CP evaluation.
2. Adopting constant current mode for CP is likely lead to overprotection and causing hydrogen evolution at the reinforcement surface.
3. Applying CP using a constant potential mode is more convenient than applying constant current mode.
4. Levels of measured corrosion rate were greater by several orders of magnitude than typically observed in practice.
5. No clear relationship was observed between the corrosion potential with chloride content/corrosion rate. However, a very clear relation has been obtained between the resistivity and the chloride content/corrosion rate.
6. Chloride analysis, concrete resistivity and corrosion rate are therefore required measurements for clear vision of the corrosion activity in structures exposed to high moisture.

Acknowledgement

This work is a part of an ongoing Ph.D. project funded by the Iraqi Ministry of Higher Education and Scientific Research Scholarship Program.

References

- [1] I. Solomon, M.F. Bird, B. Phang, An economic solution for the cathodic protection of concrete columns using a conductive tape system, *Corrosion science* 35 (1993) 1649-1660.
- [2] K.B. Pithouse, The cathodic protection of steel reinforcement in concrete, *CORROSION PREVENTION & CONTROL* (1986) 113-119.
- [3] L. Bertolini, B. Elsener, P. Pedferri, E. Redaelli, R.B. Polder, *Corrosion of steel in concrete: prevention, diagnosis, repair*, Second ed., John Wiley & Sons, Germany, 2013.
- [4] M.J. Katwan, Corrosion of steel reinforcement in concrete, in: *Proceeding of the fourth conference for corrosion and corrosion prevention in industry*, Iraq, 1999.
- [5] S.K. Verma, S.S. Bhadauria, S. Akhtar, Monitoring corrosion of steel bars in reinforced concrete structures, *The scientific world journal* (2014).
- [6] A. Popoola, O. Olorunniwo, O. Ige, Corrosion resistance through the application of anti-corrosion coatings, in: M. Aliofkhazraei (Ed.) *Developments in Corrosion Protection*, InTech, DOI: 10.5772/57420, 2014, pp. 241-270.
- [7] D. Hong, W. Fan, D. Luo, Y. Ge, Y. Zhu, Study and application of impressed current cathodic protection technique for atmospherically exposed salt-contaminated reinforced concrete structures, *ACI Materials Journal* 90 (1993).
- [8] G.T. Parthiban, T. Parthiban, R. Ravi, V. Saraswathy, N. Palaniswamy, V. Sivan, Cathodic protection of steel in concrete using magnesium alloy anode, *Corrosion Science* 50 (2008) 3329-3335.
- [9] I. Martínez, C. Andrade, Application of EIS to cathodically protected steel: Tests in sodium chloride solution and in chloride contaminated concrete, *Corrosion Science* 50 (2008) 2948-2958.
- [10] K. Wilson, M. Jawed, V. Ngala, The selection and use of cathodic protection systems for the repair of reinforced concrete structures, *Construction & Building Materials* 39 (2013) 19-25.
- [11] Y. Liu, X. Shi, Cathodic protection technologies for reinforced concrete: introduction and recent developments, *Reviews in Chemical Engineering* 25 (2009) 339-388.
- [12] P.M. Chess, J.P. Broomfield, *Cathodic protection of steel in concrete and masonry*, Second ed., CRC Press, USA, 2013.
- [13] M.M.S. Cheung, C. Cao, Application of cathodic protection for controlling macrocell corrosion in chloride contaminated RC structures, *Construction & Building Materials* 45 (2013) 199-207.
- [14] NACE SP0408-2008, *Cathodic protection of reinforcing steel in buried or submerged concrete structures*, NACE International, Houston, TX, USA, 2008.
- [15] BS EN ISO 12696:2012, *Cathodic protection of steel in concrete*, British Standards Institution, 2012.
- [16] C.L. Page, G. Sergi, Developments in cathodic protection applied to reinforced concrete, *Journal of Materials in Civil Engineering* 12 (2000) 8-15.
- [17] P. Pedferri, Cathodic protection and cathodic prevention, *Construction and Building Materials* 10 (1996) 391-402.
- [18] J.L. Kepler, D. Darwin, C.E. Locke, Evaluation of corrosion protection methods for reinforced concrete highway structures, Kansas department of transportation K-tran project No. Ku-99-6, University of Kansas centre for research, Inc. Lawrence, Kansas (2000).
- [19] H. Oleiwi, Y. Wang, M. Curioni, L. Augusthus-Nelson, X. Chen, I. Shabalin, An experimental study of the cathodic polarization of the reinforcement in chloride contaminated concrete, in: *EUROCORR*, Prague, 2017.
- [20] M. Stern, A.L. Geary, Electrochemical polarization I. A theoretical analysis of the shape of polarization curves, *Journal of the electrochemical society* 104 (1957) 56-63.
- [21] K. Kupwade-Patil, E.N. Allouche, Examination of chloride-induced corrosion in reinforced geopolymer concretes, *Journal of Materials in Civil Engineering* 25 (2012) 1465-1476.
- [22] S. Sathiyarayanan, P. Natarajan, K. Saravanan, S. Srinivasan, G. Venkatachari, Corrosion monitoring of steel in concrete by galvanostatic pulse technique, *Cement and concrete composites* 28 (2006) 630-637.
- [23] R. Huang, J.-J. Chang, J.-K. Wu, Correlation between corrosion potential and polarization resistance of rebar in concrete, *Materials Letters* 28 (1996) 445-450.

- [24] G. Qiao, B. Guo, J. Ou, F. Xu, Z. Li, Numerical optimization of an impressed current cathodic protection system for reinforced concrete structures, *Construction and Building Materials* 119 (2016) 260-267.
- [25] T. Zafeiropoulou, E. Rakanta, G. Batis, Carbonation resistance and anticorrosive properties of organic coatings for concrete structures, *Journal of Surface Engineered Materials and Advanced Technology* 3 (2013) 67.
- [26] J.-A. Jeong, C.-K. Jin, W.-S. Chung, Tidal water effect on the hybrid cathodic protection systems for marine concrete structures, *Journal of Advanced Concrete Technology* 10 (2012) 389-394.
- [27] J. Carmona, P. Garcés, M. Climent, Efficiency of a conductive cement-based anodic system for the application of cathodic protection, cathodic prevention and electrochemical chloride extraction to control corrosion in reinforced concrete structures, *Corrosion Science* 96 (2015) 102-111.
- [28] J.P. Broomfield, *Corrosion of steel in concrete: understanding, investigation and repair*, Second ed., Taylor & Francis, UK, 2007.
- [29] H.R. Soleymani, M.E. Ismail, Comparing corrosion measurement methods to assess the corrosion activity of laboratory OPC and HPC concrete specimens, *Cement and concrete research* 34 (2004) 2037-2044.
- [30] A. Poursaei, C. Hansson, Potential pitfalls in assessing chloride-induced corrosion of steel in concrete, *Cement and Concrete Research* 39 (2009) 391-400.
- [31] W. Morris, A. Vico, M. Vázquez, Chloride induced corrosion of reinforcing steel evaluated by concrete resistivity measurements, *Electrochimica Acta* 49 (2004) 4447-4453.
- [32] L. Sadowski, Methodology for assessing the probability of corrosion in concrete structures on the basis of half-cell potential and concrete resistivity measurements, *The scientific world journal* (2013).