

## PROPOSED PERMISSIBLE LIMIT STATE ASSESSMENT CRITERIA FOR MASONRY ARCH BRIDGES

M. Gilbert<sup>1</sup>, C. Melbourne<sup>2</sup>, C. C. Smith<sup>1</sup>, L. Augusthus-Nelson<sup>2</sup>, G. Swift<sup>3</sup>

<sup>1</sup> University of Sheffield, Department of Civil and Structural Engineering, Sheffield, UK.

<sup>2</sup> University of Salford, School of Computing, Science and Engineering, Manchester, UK.

<sup>3</sup> University of Portsmouth, School of Earth and Environmental Sciences, Portsmouth, UK.

e-mails: [m.gilbert@sheffield.ac.uk](mailto:m.gilbert@sheffield.ac.uk), [c.melbourne@salford.ac.uk](mailto:c.melbourne@salford.ac.uk), [c.c.smith@sheffield.ac.uk](mailto:c.c.smith@sheffield.ac.uk),  
[laugusthusnelson@salford.ac.uk](mailto:laugusthusnelson@salford.ac.uk), [garth.swift@port.ac.uk](mailto:garth.swift@port.ac.uk)

---

### SUMMARY

The Ultimate Limit State (ULS) is commonly used when assessing masonry arch bridges. Traditionally one or more, relatively large, partial factors are applied to the ULS to determine the level of service loading that can be safely applied to a given bridge. However the resulting limit on the live load capacity will sometimes prove conservative, and in other cases non-conservative, depending on the bridge makeup. To address this, an alternative, more discriminating, measure, the 'Permissible Limit State' (PLS) has recently been proposed, to be checked in conjunction with the ULS. The PLS is defined as the state which, if not exceeded, will ensure the lifespan of the bridge is not measurably reduced by repeated live loading. In this paper limiting PLS criteria based on both masonry stress range and soil-arch interaction considerations which are simple enough to be included in existing masonry arch bridge analysis software programs are considered and then applied to a bridge cyclically tested in the laboratory.

**Keywords:** *Masonry arch bridges, Permissible Limit State.*

### 1. INTRODUCTION

It is estimated that there are approximately one million masonry arch bridge spans currently in service around the world. Most are in excess of 100 years old and carry traffic which is very different to that envisaged by their constructors. Existing bridges incorporate a wide range of construction details, with one or more masonry arch elements acting as a principal means of load transfer.

In recent years there have been great advances in both the analysis tools that can be applied to masonry arch bridges, and also in available monitoring equipment, enabling collection of almost limitless amounts of data and opening up the possibility for 'smart' monitoring. However, the decision support tools currently used by bridge owners and their consultants tend to be highly simplified, and are not capable of identifying bridges which are prone to load induced deterioration. This can lead to expensive problems, something that was witnessed following the introduction of long wheelbase freight wagons in the North West of England, which led to a significant number of railway masonry arch bridges exhibiting rapid deterioration, requiring many of them to be

replaced at significant cost. Given that approaching half of the bridge spans carrying railway traffic in the UK are currently masonry, amounting to >25,000 spans [1], the need to manage them effectively is obvious (with an estimated average masonry reconstruction cost of £800k per underbridge [2], the cost to replace all bridges would be more than £20bn at 2011/12 prices). The development of predictive tools capable of discriminating between bridges with the ability to carry increased traffic loads and those which do not is therefore a pressing priority; in the absence of such tools a sound bridge may be condemned needlessly and, equally, an inadequate bridge inadvertently overloaded, potentially necessitating costly emergency intervention. In 2014 the body responsible for railway infrastructure in the UK, Network Rail, sought to take account of the uncertainty in this area by adding masonry arch bridges to their Variable Usage Charge (VUC) model, designed to pass on to freight operators the costs of usage induced wear and tear. However, Network Rail acknowledged that the new charge was quantified based on ‘top down’ engineering judgement rather than on a ‘bottom up’ estimate founded on sound understanding, because *‘the relationship between traffic growth and cost is a complex one’*; they also noted that *‘there would be considerable merit in undertaking further research in this area, particularly for brick and masonry underbridges’* [2]. The paybacks are likely to be huge. For example, research leading to the development of an improved predictive tool capable of increasing the effectiveness of the projected £3.2bn renewal cost spend [3] for railway masonry arch bridges by 10% (e.g. from 70% to 80%) would provide a payback of £320M.

Given the large numbers of bridges currently in service on our transport networks, assessment methods which are simple and quick to apply, yet which can reliably identify masonry arch bridges which are likely to degrade rapidly under a new loading regime, are clearly required. A pragmatic way forward is to enhance existing (generally ‘Ultimate Limit State’, ULS, based) masonry arch bridge analysis software to provide this capability. An alternative approach is to undertake an ‘assessment based on observation’, which can either be done in isolation, or in conjunction with an ‘assessment based on analysis’.

The paper first considers the ultimate limit state (ULS) criteria commonly applied to masonry bridges before moving on to examine potential permissible limit state (PLS) criteria, where the PLS is defined as the state which, if not exceeded, will ensure the lifespan of the bridge is not measurably reduced by repeated live loading.

## 2. CURRENT ULTIMATE LIMIT STATE ASSESSMENT CRITERIA

### 2.1. Background

At present masonry arch bridges are generally primarily assessed using Ultimate Limit State (ULS) criteria, with substantial factors of safety applied to seek to ensure that serviceability problems do not arise. The latter stems from the fact that widely accepted Serviceability Limit State (SLS) criteria for masonry arch bridges currently do not exist.

In this section some of the fundamental criteria underpinning a ULS analysis are briefly reviewed, with a view to seeing whether these can be adapted for use at other limit states.

## 2.2. Assessment based on analysis

### 2.2.1. Underpinning criteria

The ULS analysis methods currently applied to masonry arch bridges generally draw upon the theorems of plastic limit analysis, which were firmly established in the middle of the last century, and shortly afterwards interpreted in the context of masonry arch bridges by workers such as Kooharian, Heyman and others [4,5,6]. Considering the lower bound (or ‘safe’) theorem of plastic analysis, this states that the structure can be deemed to be safe providing an equilibrium state can be identified, and applicable ‘yield’ criteria are not violated. (In a masonry structure applicable ‘yield’ criteria will differ markedly to those for a steel structure, as will become evident.)

In the case of a masonry arch bridge it is usual to neglect the tensile strength of the masonry, such that bending resistance is provided by the normal force, much of it arising from gravity loads, and the thickness of the masonry cross-section. If the compressive strength of the masonry is assumed to be infinite then the applicable yield criteria for bending of a given section is shown in Fig. 1a. If Heyman’s geometrical factor of safety is used (e.g. with a value of 2, leading to a ‘middle half rule’) then the yield criteria changes to that shown in Fig. 1b. Alternatively, if no geometrical factor of safety is applied, but the finite masonry compressive strength of the masonry is accounted for, then the applicable yield criteria is as shown in Fig. 1c.

These bending ‘yield’ criteria can conveniently be shown to be satisfied by demonstrating that the thrust line (or, when masonry strength is included, ‘thrust zone’) lies within a given thickness of the masonry. Other yield criteria can be accounted for in a similar way; for example the line/zone of thrust should cross voussoirs at a sufficiently steep an angle to ensure that applicable shear (sliding) failure criteria are not violated.

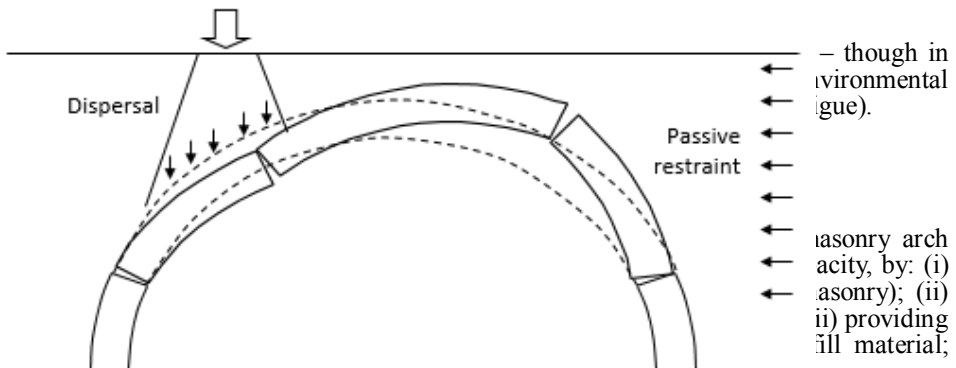
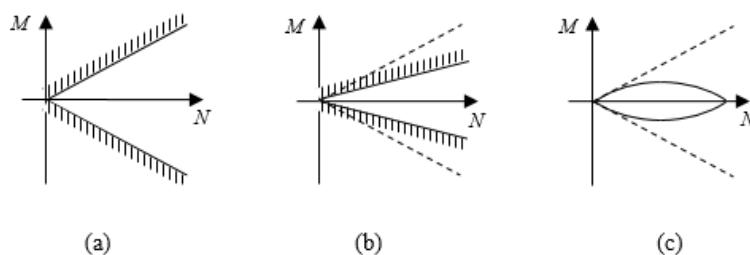
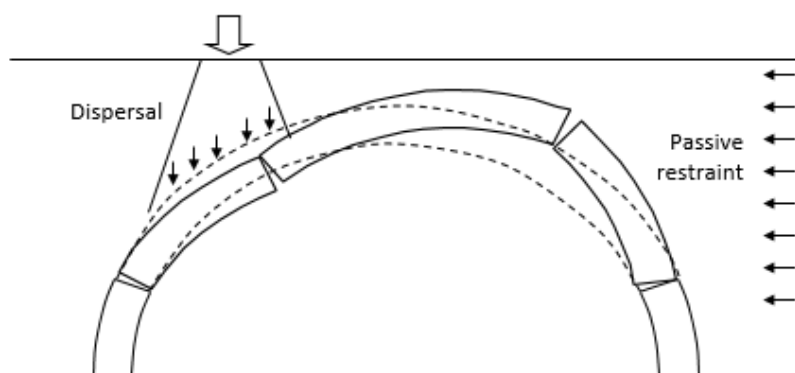

Fig. 2.



**Fig. 1.** Applicable 'yield' criteria for masonry in bending: a) at a masonry section assuming no crushing; b) as a) but with a geometrical factor of safety applied; c) as a) but with crushing

In his proposed analysis method for masonry arch bridges Heyman [5] took account of (i) and (ii), but ignored (iii). This apparent shortcoming was addressed by others in the years that followed (e.g. [6]). However, horizontal soil pressures generally require large displacements of the constituent masonry elements in order to be mobilized. Thus whilst it is justifiable to include these pressures in a ULS model, it is not so when normal vehicle load levels are involved.



**Fig. 2.** Soil-arch interaction in a masonry arch bridge (after [7]).

#### 2.2.4. The influence of live load

As pointed out by Robert Hooke in the 17<sup>th</sup> century, the pattern of loading in relation to the shape of a masonry structure governs its stability – thus it is always preferable to use real, or at least representative, loading vehicles when assessing a masonry arch bridge.

#### 2.2.5. Partial factors

For the purposes of assessment partial factors are applied to loads and materials; suitable values have been developed over time based on experience and are usually somewhat less than the values used in new design.

### 2.3. Assessment based on observation

When damage is identified that is deemed to endanger a bridge will be closed or weight restrictions will be imposed. This is clearly an inexact science, calling upon engineering judgement.

## 3. PROPOSED PERMISSIBLE LIMIT STATE ASSESSMENT CRITERIA

### 3.1. Background

Current ULS criteria are useful for guarding against collapse but do not provide an indication to bridge owners of the level of service load likely to have a detrimental effect on the life of a structure. The so-called 'Permissible Limit State' (PLS) load can be defined as the level of load which, if not exceeded, will not measurably affect the lifespan of the bridge however many times it is applied. Potential means of establishing the PLS load, drawing on methods already familiar to assessment engineers are briefly described in this section.

Key symptoms of the PLS load being exceeded include the following:

- I. Excessive deformation under a traversing vehicle, allowing progressive distortion of shape ('ratcheting') and/or loosening of masonry units etc.
- II. Material degradation due to cyclic loading effects.

(In reality I and II are clearly interlinked – with each of the above potentially exacerbating the other.)

### 3.2. Assessment based on analysis

PLS criteria I and II can be checked by analysis, utilizing some of the same methods as used for a ULS analysis.

#### 3.2.1. Criteria I: Excessive deformation under a traversing vehicle

The masonry elements of a soil-filled masonry arch bridge are usually considerably stiffer than the surrounding soil material. In particular, significant deformation of the soil is required in order to mobilize the large horizontal passive pressures encountered as the structure approaches the ULS. However, as pointed out by Smith et al. [7], the point at which these pressures *start* to be mobilized will generally lead to a break in the load-deflection curve, as the stiffness of the system starts to degrade. Thus a limit on the PLS load can be established by performing an analysis where passive pressures are ignored, with for example the soil assumed to exert 'at rest' earth pressures (i.e.  $K = K_0$ ) on the arch barrel.

Thus Fig. 3 shows sample axle load vs. position plots for a 3m span bridges backfilled either with strong ( $\phi = 50^\circ$ ) or weak ( $\phi = 30^\circ$ ) granular fill materials, showing both ULS and PLS results. All results were obtained using the LimitState:RING software [8].

It is evident from Fig. 3 that the soil strength has a significant impact on the ULS load, but does not influence the PLS significantly. This suggests that there is no fixed ratio

linking the ULS and PLS load, as has often been assumed. i.e. the application of a uniform factor on ULS (e.g. 2) is over-simplistic.

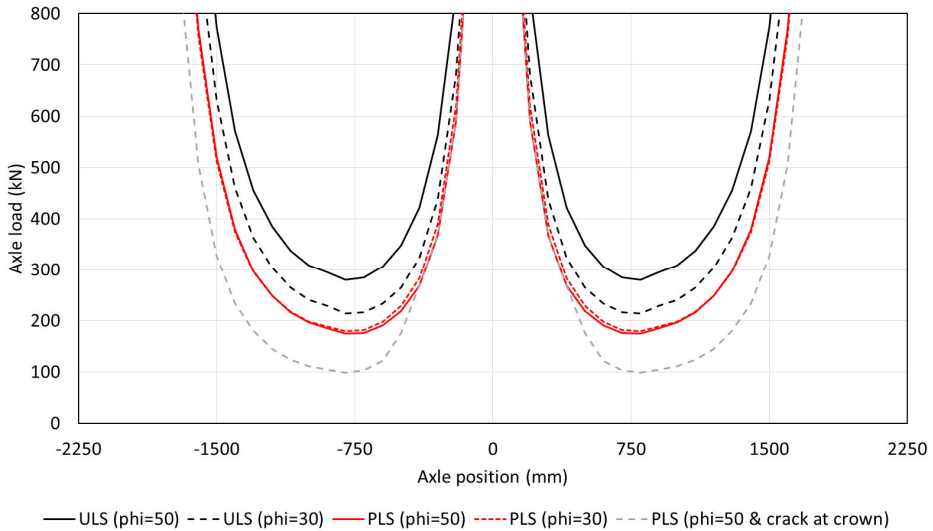

**Fig. 3.** Sample ULS & PLS axle load vs. position plots.

Also, if the arch barrel contains one or more pre-existing cracks these will affect the point at which significant movements occur, and hence should probably be included in the PLS analysis; Fig. 3 also shows the effect of including a fine transverse crack at the crown that extends halfway through the (215mm thick) arch barrel, showing that this appears to have a major impact on the computed PLS load.

### 3.2.2. Criteria II: Material degradation due to cyclic loading effects

The yield criteria presented in section 3.1 involved stress resultants rather than stresses, which need to be quantified in order for the effects of cyclic loads on masonry elements to be modelled. However, stress magnitudes can be inferred from the former if a stress distribution is prescribed. For example, considering bending, if an elasto-plastic, no-tension, stress distribution is assumed (Fig. 4) then the following relations hold [9]:

$$N = \sigma_c \frac{b}{2} (x + y) \tag{1}$$

$$M = \sigma_c \frac{b}{2} \left[ \frac{h}{2} (x + y) - \frac{1}{3} (x^2 + xy + y^2) \right] \tag{2}$$

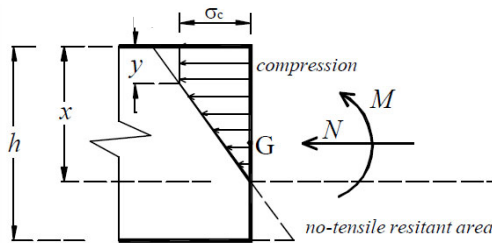

Fig. 4. Elasto-plastic stress distribution in a masonry section (after [9]).

where  $b$  is the breadth of the section and all other terms are as indicated on Fig. 4. If  $M$  and  $N$  are known then  $y$  and then  $x$  can be determined, and thus the stress at any depth  $x$  can be calculated.

In general due to its inherent statical indeterminacy, the stresses in a masonry arch bridge prior to collapse will not be known. However, bounds can be obtained simply by moving the abutments outwards and inwards (the former was assumed by Smith et al. [10] in their proposed ‘3 hinge’ analysis model). If an axle or vehicle of varying magnitude is traversed across the bridge the resulting influence line diagram for stresses can now be plotted for any location in the arch barrel. This also means that the effects of stress cycles can potentially be taken account of.

Research on the influence of the number of load cycles on the mechanical properties of masonry has been carried out by a number of workers (e.g. [11, 12]). To take account of the importance of the stress range, Casas [13] proposed an expression for compressive loading of the form:

$$S = 1.106N^{-0.1024(1-R)}, S > 0.5 \quad (3)$$

Where  $S$  is the reduction multiplier applied to the monotonic material strength,  $N$  is the number of cycles and  $R$  is the stress ratio. The stress ratio can be obtained by undertaking a numerical analysis (e.g. as outlined above) and obtaining the number of cycles can be gleaned from data on current/projected traffic on the bridge.

Alternatively equation (3), or similar equations put forward by others, can be rearranged with  $S$  set as the endurance limit (0.5, for example). This would give the number of cycles  $N_i$  ( $i = 1..k$ ) for different stress ratios  $R_i$  ( $i = 1..k$ ), where the load spectrum has been divided into  $k$  quantum steps. A ‘Miner’s Rule’ type accumulated damage calculation could then be undertaken to ensure that the cumulative effect within the whole loading spectrum is compliant with:

$$\sum_{i=1}^k \frac{n_i}{N_i} \leq 1 \quad (4)$$

where  $n_i$  is the actual number of cycles experienced at stress ratio  $R_i$ .

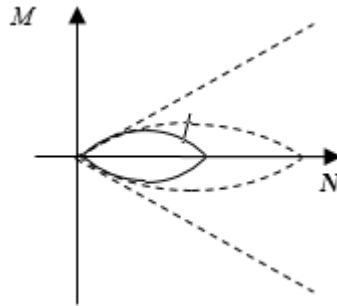

**Fig. 5.** *Cyclic loading considerations can potentially be expressed as suitably reduced yield envelopes, determined on a per section basis.*

Whatever the nature of the restrictions imposed to account for cyclic loading, these can potentially be expressed as revised ‘yield’ envelopes for masonry in bending, determined on a per section basis; e.g. see sample reduced envelope in Fig. 5.

Finally, in the aforementioned discussion the stresses have been assumed to be uniform across the width of the bridge, whereas in reality stresses are likely to be more concentrated directly under wheel loads; assuming a 3D analysis will normally be deemed unwarranted, the calculated stresses can potentially be adjusted to account for this.

### 3.3. Assessment based on observation

PLS criteria I and II described in section 3.1 can be checked for in a visual inspection, and/or via the use of suitable monitoring equipment. Caveats include: (i) it will often be quite difficult to detect minor deterioration in performance, and hence the PLS may be exceeded for some time before such deterioration is noticed; (ii) an assessment based on observation is only useful when the vehicle loading regime is not scheduled to change. This is because the observational approach brings no predictive capability *per se*. In other words evidence of previous satisfactory performance cannot be used to infer that a bridge will perform satisfactorily under a new pattern of loading, even if the axle loads themselves are not scheduled to increase significantly.

### 3.4. Commentary

The well-known MEXE method of assessment is considered to be a method of determining the service load that can be carried, and contains both ‘analysis’ and ‘observational’ elements. However, given the known limitations of the ‘analysis’ element of the method [14], the observational element of the method is arguably more useful. The lack of predictive capability associated with all such methods must however be borne in mind.



#### 4. EXAMPLE

The 3m span soil-filled brickwork arch bridge described in the paper by Augustin et al. [15] in the current conference proceedings was subjected to progressively increasing cyclic load levels (50kN, 60kN, 70kN,...), with 100,000 cycles applied in each case up until the point at which the applied loading could no longer be sustained. The load was applied via five actuators positioned across the span of the bridge, to approximately replicate the passage of a vehicle. It was found that very little damage was observed up until 70kN, though at this level a fine crack was observed between the arch barrel and one of the skewbacks. Slippage of bricks started to occur when the load level reached 80kN, with deformations under the action of the loading then increasing gradually up until 100kN, at which point falling bricks abruptly reduced the stiffness of the bridge under loading, and prevented the test from proceeding further.

For this bridge the PLS load computed using criteria I (see section 3.2.1) was found to be 70kN, which coincides with the load level at which a fine crack was observed between the arch barrel and one of the skewbacks. This suggests that the PLS calculation method proposed is likely to be reasonable (though it can also be said that 70kN coincides with half the expected collapse load for this bridge – based on the behaviour of a similar bridge subjected to a quasi-static load test to collapse).

For this bridge the use of high strength masonry units meant that PLS criteria II (material degradation due to cyclic loading) was deemed unlikely to be critical, at least if compressive failure criteria are considered. Although bricks did start to loosen and then fall out of the arch barrel at higher levels of cyclic loading, this can be considered to be linked to the increased flexibility of the bridge system, which leads to repeated opening and closing of joints. This allows non-header bricks located in tensile areas of the arch barrel to become loose and subsequently slide out under the action of gravity.

#### 5. CONCLUSIONS

The Permissible Limit State (PLS) is defined as the state which, if not exceeded, will ensure the lifespan of the bridge is not measurably reduced by repeated application of live loading. Means of checking the PLS which are relatively easy to understand and which are simple enough to be embedded in widely used masonry arch bridge analysis tools (e.g. [8]) have been outlined. Although it can be argued that considerable additional validation data is required in order for these checks to provide reliable results, particularly checks involving the fatigue performance of masonry, it can alternatively be argued that one has to start somewhere, and that even if the checks are used in conjunction with relatively generic input data, this would represent a step in the right direction.

#### ACKNOWLEDGEMENTS

The authors gratefully acknowledge the support of EPSRC (under grant references EP/I014489/1 and EP/I014357/1), Network Rail, Balfour Beatty, ADEPT and the International Union of Railways (UIC).

## REFERENCES

- [1] NETWORK RAIL, *Asset Management Policy: Civil Engineering Policy*, 2010.
- [2] NETWORK RAIL, *Letter to the ORR: Response to the Morgan Tucker report reviewing our Variable Usage Charge estimates and freight caps*, May 2012.
- [3] NETWORK RAIL, *Letter: Freight caps – consultation on variable usage charge (VUC) and freight only line charge initial cost estimates*, Nov 2011.
- [4] KOOHARIAN A., Limit Analysis of Voussoir (Segmental) and Concrete Arches, *Proc. American Concrete Institute*, Vol. 49, No. 12, 1952, pp. 317-328.
- [5] HEYMAN J., *The masonry arch*, Ellis Horwood, Chichester, 1982.
- [6] HARVEY W.J., Application of the mechanism analysis to masonry arches, *Struct. Eng. A*, Vol. 66 No. 5, 1988 pp. 77-84.
- [7] SMITH C.C., GILBERT M. and CALLAWAY P.A., Geotechnical issues in the analysis of masonry arch bridges, *Proc. 4th Int. Arch Bridges Conf.*, Barcelona, 2004, pp. 343-352.
- [8] LIMITSTATE LTD, *LimitState:RING masonry arch bridge analysis software, version 3.1b*, 2014.
- [9] BRENCICH A., DE FRANCESCO U. and GAMBAROTTA L., Elastic no tensile resistant-plastic analysis of masonry arch bridges as an extension of Castigliano's method, *Proc. 9th Canadian Masonry Symposium*, 2001.
- [10] SMITH F.W., HARVEY W.J. and VARDY A.E., Three-hinge analysis of masonry arches, *Structural Engineer*, Vol. 68 No. 11, 1990, pp. 203-207.
- [11] ROBERTS T.M., HUGHES T.G., DANDAMUDI V.R., AND BELL B., Quasi-static and high-cycle fatigue strength of brick masonry, *Construction and Building Materials*, Vol. 20, pp. 603-14.
- [12] WANG J., TOMOR A.K., MELBOURNE C. AND YOUSIF S., Critical review of research on high-cycle fatigue behaviour of brick masonry, *Construction and Building Materials*, 38, 2013, pp. 602-609.
- [13] CASAS J.R., A probabilistic fatigue strength model for brick masonry under compression, *Construction and Building Materials*, Vol. 23, No. 8, 2009, pp. 2964–72.
- [14] WANG J. and MELBOURNE C., Mechanics of MEXE method for masonry arch bridge assessment. *Proc. ICE - Engineering and Computational Mechanics*, Vol. 163, No. 3, 2010, pp. 187-202.
- [15] AUGUSTHUS-NELSON L., SWIFT G, SMITH C.C., GILBERT M. and MELBOURNE C., Behaviour of backfilled masonry arch bridges subjected to cyclic loading, *Proc. 8th Int. Arch Bridges Conf.*, Wroclaw, 2016, submitted.