

**DEVELOPMENT OF TRAFFIC MICRO-SIMULATION  
MODEL FOR MOTORWAY MERGES WITH RAMP  
METERING**

**Jalal Taqi Shaker AL-OBAEDI**

School of Computing, Science and Engineering (CSE)  
University of Salford, Salford, UK

Submitted in Partial Fulfilment of the Requirements of the Degree of Doctor  
of Philosophy, 2011

# Table of contents

Table of contents.....	ii
List of Tables .....	vii
List of Figures.....	ix
Acknowledgements.....	xv
Declaration.....	xvi
Dedication.....	xvii
Abbreviations.....	xviii
Symbols .....	xix
Abstract.....	xxi
Chapter One : INTRODUCTION.....	1
1.1. Background.....	1
1.2. Aim and objectives .....	2
1.3. Thesis outline.....	2
Chapter Two : TRAFFIC SIMULATION MODELS.....	4
2.1. Introduction.....	4
2.2. Simulation approaches.....	4
2.3. Micro-simulation modelling process .....	5
2.3.1. Car following (CF) models.....	5
2.3.2. Lane changing (LC) models .....	11
2.3.3. Merging models.....	13
2.3.4. Review of gap acceptance models.....	16
2.4. Summary.....	18
Chapter Three : TRAFFIC CONGESTION AND MANAGEMENT CONTROLS.....	19
3.1. Introduction.....	19
3.2. Causes of traffic congestion.....	19
3.3. Effect of congestion on motorway capacity .....	20
3.4. Traffic congestion solutions.....	21
3.5. Speed limit controls .....	21
3.6. Ramp metering (RM) controls.....	22
3.6.1. Evolution of RM.....	22
3.6.2. RM components.....	23
3.6.3. RM algorithms .....	24
3.6.3.1. Demand-Capacity (D-C) algorithm.....	25
3.6.3.2. Demand Capacity INRETS.....	25
3.6.3.3. RWS algorithm .....	26
3.6.3.4. Percent occupancy algorithm.....	26
3.6.3.5. ALINEA algorithm .....	26
3.6.3.6. ALINEA extended algorithms .....	26
3.6.3.7. Speed-Occupancy algorithm.....	29
3.6.3.8. ANCONA algorithm.....	29



3.6.3.9. Ramp metering pilot scheme algorithm (RMPS) .....	30
3.6.3.10. Other RM algorithms .....	30
3.6.4. Summary of the RM algorithms .....	31
3.6.5. Queue override strategies (QOSs) .....	32
3.6.6. Evaluation studies for RM .....	34
3.6.6.1. Empirical studies.....	34
3.6.6.2. Simulation studies.....	36
3.6.6.3. Limitations in the RM evaluation studies .....	38
3.7. Summary .....	38
Chapter Four : DATA COLLECTION AND ANALYSIS .....	40
4.1. Introduction.....	40
4.2. Methods of data collection.....	40
4.3. Site selection and description of the data obtained.....	41
4.4. Effect of vehicle types on “close following” behaviour .....	42
4.4.1. Background.....	43
4.4.2. Description of the data.....	44
4.4.3. Methodology .....	45
4.4.4. Results and discussion .....	52
4.4.5. Comparison with other models .....	59
4.5. Lane utilisation .....	60
4.5.1. Introduction and background .....	60
4.5.2. Lane utilisation for motorway traffic at normal sections.....	62
4.5.2.1. Testing of previous models.....	62
4.5.2.2. Development of new regression models.....	64
4.5.3. Lane utilisation for motorway traffic at merge sections .....	68
4.5.4. Lane utilisation of slip road (merge) traffic .....	70
4.5.4.1. Lane utilisation before the merge section (Position 1) .....	70
4.5.4.2. Lane utilisation at the start of merge section (Position 2) .....	71
4.5.5. Lane utilisation of heavy goods vehicles .....	71
4.5.5.1. Testing of previous HGVs’ lane utilisation models.....	72
4.5.5.2. Development of new models .....	74
4.6. Headway distribution.....	76
4.6.1. Simple headway models .....	76
4.6.2. Composite headway models .....	77
4.6.3. Testing headway models using real data .....	78
4.7. Lane changing.....	82
4.7.1. Frequency of lane changes (FLC).....	82
4.7.2. Manoeuvring time for lane changing.....	84
4.8. Merging behaviour.....	85
4.8.1. Merging position.....	85
4.8.2. Gap selection behaviour.....	86
4.8.3. Merge ratio.....	87

4.8.4.	Cooperative and yielding behaviour .....	88
4.8.5.	Size of accepted gaps .....	89
4.9.	Data related to RM.....	90
4.9.1.	Estimation of critical occupancy values for UK motorways .....	90
4.9.1.1.	Introduction and background .....	90
4.9.1.2.	Application of occupancy in RM.....	92
4.9.1.3.	Methodology .....	92
4.9.1.4.	Results and discussions.....	93
4.9.2.	Compliance of drivers with the timings of RM signals .....	98
4.9.3.	Effectiveness of RM .....	98
4.10.	Summary .....	101
Chapter Five : MODEL DEVELOPMENT .....		102
5.1.	Introduction.....	102
5.2.	Geometric layouts .....	102
5.3.	Count stations .....	103
5.4.	Scanning time .....	103
5.5.	General structure of the simulation model.....	105
5.6.	Drivers`/vehicles` characteristics.....	106
5.6.1.	Drivers` reaction time .....	106
5.6.2.	Vehicle lengths .....	107
5.6.3.	Vehicle acceleration and deceleration rates.....	110
5.7.	Traffic flow characteristics` inputs .....	111
5.7.1.	Flow rates and traffic composition .....	111
5.7.2.	Headway distribution.....	111
5.7.3.	Desired speed.....	114
5.8.	Car following rules .....	116
5.8.1.	Introduction.....	116
5.8.2.	Types of acceleration rates .....	116
5.8.3.	Selection criteria for the acceleration rate .....	119
5.8.4.	Comparison with CARSIM .....	120
5.9.	Lane changing rules .....	121
5.9.1.	Discretionary lane changing (DLC) rules.....	122
5.9.1.1.	The desirability of LC .....	123
5.9.1.2.	The feasibility of LC .....	123
5.9.1.3.	Additional rules.....	126
5.9.2.	Merging (mandatory) rules .....	127
5.9.2.1.	Merging traffic behaviour .....	128
5.9.2.2.	Motorway traffic behaviour .....	132
5.9.2.3.	Drivers` behaviour during and after the merging process .....	132
5.10.	Modelling of ramp metering (RM) .....	133
5.10.1.	Turn on/off criteria.....	133
5.10.2.	Calculation of the metering rate.....	134

5.10.3.	Calculation of signal timings .....	134
5.10.4.	Modelling of drivers' compliance with signal timings .....	135
5.11.	Model capabilities .....	136
5.12.	Summary .....	136
Chapter Six : MODEL VERIFICATION, CALIBRATION AND VALIDATION .....		137
6.1.	Introduction .....	137
6.2.	Statistical tests .....	138
6.3.	Model verification .....	140
6.3.1.	Car following rules (CFR) .....	140
6.3.2.	Lane changing rules .....	141
6.3.3.	Merging rules .....	141
6.4.	Model calibration .....	143
6.4.1.	Car following rules (CFR) .....	143
6.4.2.	Lane changing rules .....	148
6.4.3.	Merging rules .....	154
6.5.	Model validation .....	157
6.5.1.	Comparison with M56 J2 data .....	158
6.5.2.	Comparison with M62 J11 data .....	162
6.5.3.	Comparison with M6 J20 data .....	165
6.6.	Comparison with S-Paramics' software .....	168
6.7.	Summary .....	169
Chapter Seven : MODEL APPLICATIONS (WITHOUT THE USE OF RAMP METERING) .....		170
7.1.	Introduction .....	170
7.2.	Effect of HGVs on capacity .....	170
7.2.1.	Background .....	170
7.2.2.	Methodology .....	170
7.2.3.	Results .....	171
7.2.4.	Estimation of HGVs' equivalency factor .....	173
7.3.	Effect of merge ratio on capacity .....	174
7.4.	Effect of cooperative behaviour .....	175
7.4.1.	Effect of cooperative behaviour on stopping cases .....	175
7.4.2.	Effect of cooperative behaviour on travel time .....	176
7.5.	Management of merge sections without the use of RM .....	179
7.5.1.	Effect of speed limits .....	179
7.5.2.	Effect of Lane Changing Restrictions (LCR) .....	181
7.6.	Summary .....	184
Chapter Eight : MODEL APPLICATIONS (WITH RAMP METERING) .....		185
8.1.	Introduction .....	185
8.2.	Optimum parameters of RM algorithms .....	185
8.2.1.	Introduction .....	185
8.2.2.	Methodology .....	185

8.2.3.	Results from selected RM algorithms.....	187
8.2.3.1.	ALINEA algorithm.....	187
8.2.3.2.	D-C algorithm.....	191
8.2.3.3.	ANCONA algorithm.....	192
8.3.	Effectiveness of RM controls .....	195
8.3.1.	Effect of RM on time spent for different algorithms.....	195
8.3.2.	Effect of RM on traffic delay (a typical example).....	198
8.4.	Improvements to the ANCONA algorithm.....	199
8.4.1.	Introduction.....	199
8.4.2.	New ANCONA derivative algorithms.....	200
8.4.2.1.	(ANCONA-M1): Enhancing the shutting downing criteria .....	200
8.4.2.2.	(ANCONA-M2): Based on different speed levels.....	200
8.4.2.3.	(ANCONA-M3): Considering the ramp flow rates .....	201
8.4.2.4.	Hybrid ALINEA-ANCONA (AL-AN) algorithm .....	202
8.4.3.	Selected parameters .....	202
8.4.4.	Effectiveness of the ANCONA derivative algorithms .....	204
8.5.	Further tests using a selection of RM algorithms .....	206
8.5.1.	Effect of ramp length .....	206
8.5.1.1.	Effect of ramp length using the ALINEA algorithm .....	206
8.5.1.2.	Effect of ramp length using the ANCONA-M2 algorithm.....	208
8.5.2.	Effectiveness of RM under different peak periods .....	209
8.5.3.	Effectiveness of RM with a one lane ramp section .....	214
8.5.4.	Effectiveness of RM with further downstream bottlenecks.....	216
8.5.5.	Effect of traffic signals' position .....	219
8.5.6.	Effect of total cycle length.....	219
8.5.7.	Testing of queue override strategies (QOSs).....	221
8.6.	Comparison between RM and LCR.....	223
8.7.	Summary.....	225
Chapter Nine : CONCLUSIONS AND FURTHER RESEARCH.....		226
9.1.	Conclusions.....	226
9.1.1.	Data collection and analysis .....	226
9.1.2.	Model development .....	228
9.1.3.	Model applications (without the use of RM).....	229
9.1.4.	Model applications (with RM).....	230
9.2.	Recommendations and further research.....	232
9.2.1.	Data collection and analysis .....	232
9.2.2.	Enhancing the developed simulation model .....	233
9.2.3.	Modelling of RM .....	233
9.2.4.	Practical implementations.....	233
References.....		234
References from the web .....		243
Appendix A : Effect of vehicle type on the following behaviour.....		244

Appendix B : Computer programs used in analysing the individual vehicles' data (IVD).....	256
Appendix C : Computer program used for estimating the critical occupancy.....	261
Appendix D : Effectiveness of ramp metering .....	262
Appendix E : Verification of the car following rules .....	265

## List of Tables

Table 2-1 Critical gap for merge traffic (Source: Worrall <i>et al.</i> , 1967) .....	17
Table 3-1 Signal timings for the M60 J2 RM site, UK.....	30
Table 3-2 The required measurements for each RM algorithm.....	31
Table 3-3 Summary of some of the empirical studies that have evaluated RM .....	36
Table 3-4 Summary of some of the simulation studies that have evaluated RM .....	39
Table 4-1 Summary of the selected sites and how the data was used .....	42
Table 4-2 Summary of some previous studies examining "close following" behaviour....	44
Table 4-3 Typical ranges for lengths of vehicles (Source: Yousif and Al-Obaedi, 2011) .	45
Table 4-4 Summary of selected criteria for tests .....	48
Table 4-5 Size of the analysed sample with respect to the selected criteria for the M25 ...	51
Table 4-6 Size of the analysed sample with respect to the selected criteria for the M42 ...	51
Table 4-7 Differences in the average following distance (m) for test No.1 for the M25 ...	56
Table 4-8 Differences in the average following distance (m) for test No.1 for the M42 ...	57
Table 4-9 Testing some of the previous lane utilisation models (using existing traffic data).....	63
Table 4-10 Testing previous models of HGVs' lane utilisation using data from the M42 and M25 motorways.....	72
Table 4-11 Regression models for HGVs' lane utilisation.....	75
Table 4-12 Statistical results for testing goodness of fit for the headway distribution models using K-S test .....	82
Table 4-13 Traffic that merge before and after the nose length .....	86
Table 4-14 Estimated $O_{cr}$ and $O_{des}$ values in use in some RM sites in UK .....	97
Table 4-15 Vehicles going through during cycle time periods for the M56 J2 RM.....	98
Table 5-1 Summary of drivers' reaction time based on previous research .....	106
Table 5-2 Vehicle lengths (Source: El-Hanna, 1974).....	107
Table 5-3 Vehicle lengths (m) based on data from the M42 .....	108
Table 5-4 The mechanical limit for acceleration rates ( $m/sec^2$ ) for passenger cars and HGVs for different speed levels (Source: ITE, 1999) .....	111
Table 5-5 Mean speed and standard deviation for motorway lanes (Source: Burrow, 1974) .....	115
Table 5-6 Mean speeds and standard deviations for 3-lane motorway (Source: Yousif, 1993) .....	115
Table 5-7 Average and standard deviation (sec) for manoeuvring time for LC .....	127
Table 6-1 Summary for the RMSE values obtained from the simulation .....	148
Table 6-2 The selected parameters for calibration of lane changing rules .....	149
Table 6-3 Real traffic data from the M25 J11 (Source: Wang, 2006).....	154

Table 6-4	Kolmogorov-Smirnov test for the distribution of simulated lead and lag gaps	156
Table 6-5	Flow inputs of the M60 J10.....	156
Table 6-6	Statistical tests for the developed model based on data from the M56 J2.....	162
Table 6-7	Statistical tests for the developed model based on data from the M62 J11.....	165
Table 6-8	Statistical tests for the developed model based on data from the M6 J20.....	168
Table 6-9	RMSEP (%) obtained from the model and from the S-Paramics model.....	169
Table 7-1	Flow levels used in testing the effect of cooperative behaviour .....	175
Table 8-1	Flows selected in finding the optimum parameters for RM algorithms.....	186
Table 8-2	Optimum $O_{des}$ at each selected loop detectors' position .....	188
Table 8-3	The combinations of Sp1 and P used in optimisation of the ANCONA algorithm.....	194
Table 8-4	Saving in TTSM, TTSR and TTS with a 90 minutes' peak period.....	210
Table 8-5	Saving in TTSM, TTSR and TTS with a 60 minutes' peak period.....	211
Table 8-6	Saving in TTSM, TTSR and TTS with a 30 minutes' peak period.....	212
Table 8-7	Saving in TTSM, TTSR and TTS with a 15 minutes' peak period.....	213
Table 8-8	Flow rates (veh/hr) that used in testing the effect of cycle length .....	219
Table A-1	Typical example for the IVD data .....	245
Table A-2	Example for the separated IVD per lane .....	246
Table A-3	Example for the final output.....	246
Table A-4	Average following distance (m) for test No.1 and for the M25 .....	247
Table A-5	Average following distance (m) for test No.1 and for the M42 .....	247
Table A-6	Average following distance (m) for test No.2 and for the M25 .....	248
Table A-7	Average following distance (m) for test No.2 and for the M42 .....	248
Table A-8	Average following distance (m) for test No.3 and for the M25 .....	249
Table A-9	Average following distance (m) for test No.3 and for the M42 .....	249
Table A-10	Average following distance (m) for test No.4 and for the M25 .....	250
Table A-11	Average following distance (m) for test No.4 and for the M42 .....	250
Table A-12	Average following distance (m) for test No.5 and for the M25 .....	251
Table A-13	Average following distance (m) for test No.5 and for the M42 .....	251
Table A-14	Average following distance (m) for test No.6 and for the M25 .....	252
Table A-15	Average following distance (m) for test No.6 and for the M42 .....	252
Table A-16	Average following distance (m) for test No.7 and for the M25 .....	253
Table A-17	Average following distance (m) for test No.7 and for the M42 .....	253
Table A-18	Average following distance (m) for test No.8 and for the M25 .....	254
Table A-19	Average following distance (m) for test No.8 and for the M42 .....	254
Table A-20	Average following distance (m) for test No.9 and for the M25 .....	255
Table A-21	Average following distance (m) for test No.9 and for the M42 .....	255

## List of Figures

Figure 2-1	The visual angle $\theta$ .....	8
Figure 2-2	Illustration of lead and lag gaps .....	11
Figure 2-3	The general structure of the lane changing model .....	11
Figure 2-4	DLC proposed by Ahmed (1999).....	13
Figure 2-5	Position of the merger with respect to the available gaps.....	16
Figure 3-1	Causes of traffic congestion (Source: FHWA, 2004) .....	19
Figure 3-2	Operational capacity (Source: Wu <i>et al.</i> , 2010).....	20
Figure 3-3	Example of RM system (Source: Highways Agency, 2007) .....	24
Figure 3-4	Procedure of estimating the critical occupancy in AD-ALINEA algorithm.....	28
Figure 3-5	Flowchart of Gordon's (1996) QOS .....	33
Figure 4-1	Summary of parameters studied.....	41
Figure 4-2	Following distance for C-C for each lane of the M25 and the M42 .....	50
Figure 4-3	Comparing the following distance and the following headway between the cases of C-C and C-H using data from the M25 for test No.1 .....	53
Figure 4-4	Comparing the following distance and the following headway between the cases of H-H and H-C using data from the M25 for test No.1 .....	54
Figure 4-5	The following distance and the following headway between the cases of C-C and C-H using data from the M42 for test No.1 .....	55
Figure 4-6	The following distance and the following headway between the cases of H-H and H-C using data from the M42 for test No.1 .....	56
Figure 4-7	Examples for the cumulative distribution of the following distances based on the M25 data.....	57
Figure 4-8	Observed average following distance with speeds compared with other theoretical models .....	60
Figure 4-9	Lane utilisation for the M602 motorway (two lanes) .....	65
Figure 4-10	Lane use behaviour in the UK and Germany (Ger) for sections with 2 lanes .....	65
Figure 4-11	Lane utilisation for the M62 motorway (three lanes) .....	66
Figure 4-12	Lane utilisation for the M25 motorway (four lanes).....	67
Figure 4-13	Detectors' locations for the M56 J2 .....	68
Figure 4-14	Average lane utilisation for location U1 .....	68
Figure 4-15	Average lane utilisation in lane 1 for locations U1 and U2 .....	69
Figure 4-16	Average lane utilisation for location D1 .....	69
Figure 4-17	The M56 J2 section showing positions 1 and 2 .....	70
Figure 4-18	Lane utilisation for a 2-lane on-ramp (M56 J2) at Position 1 .....	70
Figure 4-19	Lane utilisation for a 2-lane on-ramp on the nose section for the M56 J2 .....	71
Figure 4-20	HGVs' lane utilisation for the M42 with respect to HGVs' flow ( $q_h$ ) compared with the Hollis and Evans (1976) and the Turner (1983) models.....	73
Figure 4-21	HGVs' lane utilisation for the M42 with respect to total flow ( $q$ ) compared with the Turner (1983) model .....	73
Figure 4-22	Actual and predicted cumulative distribution of headways in lanes 1 and 2 on the M42 using the shifted negative exponential distribution .....	79

Figure 4-23	Actual and predicted cumulative distribution of headways in lane 3 of the M42 using the shifted negative exponential distribution.....	79
Figure 4-24	Actual and predicted cumulative distribution of headways in lanes 1 and 2 of the M42 using the generalised queuing model.....	80
Figure 4-25	Actual and predicted cumulative distribution of headway in lane 3 on the M42 using the generalised queuing model.....	80
Figure 4-26	Actual and predicted cumulative distribution of headways in lanes 1 and 2 on the M42 using the double negative exponential model.....	81
Figure 4-27	Actual and predicted cumulative distribution of headways in lane 3 on the M42 using the double negative exponential model.....	81
Figure 4-28	FLC for 3-lane motorway sections.....	82
Figure 4-29	FLC for the M602 and the M4 with 2 lanes.....	83
Figure 4-30	FLC for the M60 with 4 lanes.....	84
Figure 4-31	Distribution of manoeuvring time for lane changing.....	85
Figure 4-32	Cumulative distribution for merging position based on data from the M60 J10.....	86
Figure 4-33	Illustration of the first, next and previous gaps in merging behaviour.....	87
Figure 4-34	Relationship between relative speeds on the size of accepted lead and lag gaps.....	90
Figure 4-35	Flow-occupancy relationship based on data from the M6 J23 (3-lane motorway).....	91
Figure 4-36	Occupancy-density relationship based on data from the M6 J23 (3-lane motorway).....	91
Figure 4-37	Flow occupancy relationship for the M56 J2 (2-lane motorway) with different trial values of $O_{cr}$ .....	94
Figure 4-38	Flow occupancy relationship for the M60 J2 (3-lane motorway) with different trial values of $O_{cr}$ .....	95
Figure 4-39	Flow occupancy relationship for the M6 J23 (3-lane motorway) with different trial values of $O_{cr}$ .....	96
Figure 4-40	Flow occupancy relationship for the M6 J20 (4-lane motorway) with different trial values of $O_{cr}$ .....	97
Figure 4-41	Average speed and occupancy values for the M6 J20 site.....	100
Figure 5-1	Geometric layout considered in the model (Highways Agency, 2008).....	104
Figure 5-2	Measurements of the timings used in the calculations for speed and occupancy.....	104
Figure 5-3	General structure of the developed model.....	105
Figure 5-4	Numbering (a) and renumbering (b) the vehicles at each scan time.....	106
Figure 5-5	Drivers' reaction time based on Johansson and Rumer (1971) (Source: Yousif, 1993).....	107
Figure 5-6	Distribution of car lengths based on data from the M42.....	108
Figure 5-7	Distribution of HGVs' lengths based on data from the M42.....	109
Figure 5-8	Cumulative distribution for car lengths based on data from the M42.....	109
Figure 5-9	Cumulative distribution for HGVs' lengths based on data from the M42.....	110
Figure 5-10	Method of estimating vehicle lengths.....	110
Figure 5-11	The double exponential distribution model.....	114



Figure 5-12	The generalised queuing model .....	114
Figure 5-13	Cumulative distribution for move-up delay based on data from the M60 ....	119
Figure 5-14	The general structure of the car following rules .....	120
Figure 5-15	Acceleration of vehicles in platoon using CARSIM (Source: Aycin and Benekohal, 2001) .....	121
Figure 5-16	Acceleration rates for vehicles in the platoon.....	121
Figure 5-17	The general structure of DLC .....	122
Figure 5-18	Surrounding traffic that affects the LC of vehicle C.....	123
Figure 5-19	Feasibility of LC towards right lanes.....	124
Figure 5-20	Illustration for the D parameter.....	125
Figure 5-21	Feasibility of LC toward left lanes.....	126
Figure 5-22	Acceleration rates during LC manoeuvring.....	127
Figure 5-23	Structure of drivers' behaviour within a merge section.....	127
Figure 5-24	Drivers' situations with respect to the size of lead and lag gaps .....	130
Figure 5-25	Merger actions with respect to available gaps .....	130
Figure 5-26	Merging interaction – projected positions and speeds of vehicles.....	131
Figure 6-1	Simulation study workflow (Source: Olstam and Tapani, 2011).....	137
Figure 6-2	Typical screen from the model.....	140
Figure 6-3	Merger vehicle with respect to motorway traffic.....	142
Figure 6-4	Instrumented data Set 1 (from Germany) showing clear spacing and leading vehicle speed profiles based on Panwai and Dia (2005).....	144
Figure 6-5	Instrumented data Set 1 (from Germany) showing relative speed between the leading and the following vehicles based on Panwai and Dia (2005) .....	144
Figure 6-6	Actual and simulated clear spacing based on data Set 1 .....	145
Figure 6-7	Actual and simulated clear speed based on data Set 1 .....	145
Figure 6-8	Instrumented data Set 2 (from USA) showing clear spacing and leading vehicle speed profiles based on Sauer and Andersen (2004) .....	146
Figure 6-9	Actual and simulated clear spacing based on data Set 2.....	146
Figure 6-10	Sections covered by video cameras, (Source: <a href="http://ops.fhwa.dot.gov/trafficanalysistools/ngsim.htm">http://ops.fhwa.dot.gov/trafficanalysistools/ngsim.htm</a> ) .....	147
Figure 6-11	Actual time-space diagram for the platoon of vehicles.....	147
Figure 6-12	Simulated time-space diagram for the platoon of vehicles.....	147
Figure 6-13	Lane utilisation coefficients for the M62 (3-lane section).....	148
Figure 6-14	Simulated lane utilisation coefficients for a 3-lane section with different values of the "D" parameter.....	150
Figure 6-15	Simulated FLC for a 3-lane section with different values of the "D" parameter.....	151
Figure 6-16	Simulated FLC for a 3-lane section with different values of the "PD" parameter.....	151
Figure 6-17	Simulated lane utilisation coefficients for a 3-lane section with different values of the "PD" parameter.....	152
Figure 6-18	Actual and simulated lane utilisation factors for a 2-lane motorway .....	153
Figure 6-19	Simulated FLC for a 2-lane section .....	153

Figure 6-20	Actual and simulated distribution for merging lead gaps .....	155
Figure 6-21	Actual and simulated distribution for merging lag gaps .....	155
Figure 6-22	Simulated lead gaps and the minimum observed lead .....	157
Figure 6-23	Simulated lag gaps and the minimum observed lag.....	157
Figure 6-24	Locations of the loop detectors on the M56 J2 .....	158
Figure 6-25	Actual input flow for the motorway and the ramp.....	159
Figure 6-26	Actual and simulated flows and speeds at detectors' station D2 .....	159
Figure 6-27	Actual input flow for the motorway and the ramp sections.....	160
Figure 6-28	Actual and simulated flow and speed at detectors' station D1 .....	161
Figure 6-29	Actual and simulated flow in lanes 1 and 2 at detectors' station D1 .....	161
Figure 6-30	Actual and simulated speed-flow and flow-occupancy relationships.....	162
Figure 6-31	Locations of the loop detectors at the M62 J11 .....	163
Figure 6-32	Actual input flow for the motorway and ramp sections at the M62 J11 .....	163
Figure 6-33	Actual and simulated flow, speed and travel time for the M62 J11.....	164
Figure 6-34	Actual and simulated lane utilisation factors for the M62 J11 .....	165
Figure 6-35	Locations of the loop detectors at the M6 J20 .....	166
Figure 6-36	Actual input flow for the motorway and ramp sections at the M6 J20.....	166
Figure 6-37	Actual and simulated flow, speed and occupancy at detectors' station D1 ..	167
Figure 6-38	Actual and simulated lane utilisation factors for the M6 J20 .....	168
Figure 7-1	The geometry used in testing the effect of HGVs (snapshot from the model)	171
Figure 7-2	Estimation of the capacity value for $q_{in}=5000$ veh/hr with 15% HGVs .....	171
Figure 7-3	Maximum merge traffic prior to occurrence of congestion for a 2-lane section .....	172
Figure 7-4	Maximum merge traffic prior to occurrence of congestion for a 3-lane section .....	172
Figure 7-5	Simulated and actual capacity with respect to the percentage of HGVs for a 2-lane section.....	173
Figure 7-6	Capacity values in pcu/hr corresponding to PCE values .....	174
Figure 7-7	Effect of merge ratio on downstream capacity for a section with 3 lanes .....	175
Figure 7-8	Effect of cooperative drivers on stopping and cooperative cases for flow level 1 .....	176
Figure 7-9	Effect of cooperative drivers on stopping and cooperative cases for flow level 2.....	176
Figure 7-10	Effect of cooperative drivers on travel time for flow level 1 .....	177
Figure 7-11	Effect of cooperative drivers on travel time for flow level 2 .....	178
Figure 7-12	Effect of the length of the auxiliary lane on the time saving obtained from cooperative behaviour .....	178
Figure 7-13	Effect of speed limit on time spent .....	180
Figure 7-14	Effect of speed limit on motorway upstream throughput .....	180
Figure 7-15	Speed profile for motorway lanes without using of speed limits.....	181
Figure 7-16	LCR section.....	182
Figure 7-17	Time spent obtained from without control. speed limit and LCR (Scenario 1).....	183

Figure 7-18 Effect of applying “Scenario 2” on the speed profile .....	183
Figure 7-19 Time spent obtained from without control, speed limit and LCR .....	184
Figure 8-1 The geometry used in testing RM (snapshot from the model).....	185
Figure 8-2 Selected input flows for simulation in the “primary optimisation process” ...	186
Figure 8-3 Effect of selected $O_{des}$ time spent using ALINEA algorithm.....	189
Figure 8-4 Effect of $O_{des}$ on motorway throughput and speed using ALINEA algorithm	189
Figure 8-5 Effect of $O_{des}$ on traffic delay using ALINEA algorithm.....	190
Figure 8-6 Effect of $O_{des}$ on the ramp queue length using ALINEA algorithm .....	190
Figure 8-7 TTS obtained from the ALINEA with the flow rates given in Table 8-1 .....	191
Figure 8-8 Effect of $O_{cr}$ on upstream throughput using the D-C algorithm .....	192
Figure 8-9 Effect of $O_{cr}$ on TTS using the D-C algorithm .....	192
Figure 8-10 TTS obtained from the D-C algorithm with the flow rates given in Table 8-1 .....	192
Figure 8-11 Effect of Sp1 and P parameters of the ANCONA algorithm.....	193
Figure 8-12 TTS obtained from the ANCONA algorithm with P and Sp1 values.....	194
Figure 8-13 TTS obtained from P=10 minutes and variable P value .....	195
Figure 8-14 Saving in TTSM obtained from using different RM algorithms .....	197
Figure 8-15 Saving in TTSR obtained from using different RM algorithms .....	197
Figure 8-16 Saving in TTS obtained from using different RM algorithms.....	198
Figure 8-17 Effect of RM on traffic delay.....	199
Figure 8-18 The ANCONA-M1 algorithm.....	200
Figure 8-19 The ANCONA-M2 algorithm.....	201
Figure 8-20 The ANCONA-M3 algorithm.....	201
Figure 8-21 The hybrid AL-AN algorithm.....	202
Figure 8-22 Effect of Sp1 on travel spent using the ANCONA-M2 algorithm.....	203
Figure 8-23 TTS obtained from the ANCONA-M2 algorithm with flow rates given in Table 8-1 .....	204
Figure 8-24 TTS obtained from the ANCONA-M3 algorithm with flow rates given in Table 8-1 .....	204
Figure 8-25 Saving in time spent obtained from the original ANCONA and its developed derivations.....	205
Figure 8-26 Effect of ramp length on motorway throughput and speed using the ALINEA algorithm.....	207
Figure 8-27 Effect of ramp length on the time spent using the ALINEA algorithm.....	207
Figure 8-28 Effect of selected $O_{des}$ on queue length using the ALINEA algorithm.....	208
Figure 8-29 Effect of selected $O_{des}$ on upstream speed with no queue control .....	208
Figure 8-30 Effect of ramp length on motorway throughput and on motorway upstream speed using the ANCONA-M2 algorithm .....	209
Figure 8-31 Comparison between queue lengths obtained by using the ALINEA and ANCONA-M2 algorithms.....	209
Figure 8-32 Ranges of flows at which RM is effective in reducing the TTS .....	214
Figure 8-33 Savings in TTSM, TTSR and TTS obtained from a single lane ramp section with a 60 minutes` peak period.....	215

Figure 8-34	Savings in TTSM, TTSR and TTS obtained from a single lane ramp section for a 30 minutes' peak period .....	216
Figure 8-35	A snapshot from the model showing the geometry of the two merge sections.....	217
Figure 8-36	Effectiveness of RM with detectors position at 100m upstream of merge 2	218
Figure 8-37	Effectiveness of RM with detectors position at 200m upstream of merge 2	218
Figure 8-38	Effect of the position of the traffic signals on the time spent .....	219
Figure 8-39	Effect of cycle length on travel time using the ALINEA algorithm .....	220
Figure 8-40	Queue lengths created upstream of the stop line.....	220
Figure 8-41	Effect of queue override strategies on TTS .....	222
Figure 8-42	Occupancy obtained from the QOD.....	222
Figure 8-43	Comparing the time savings obtained by using LCR and RM .....	224
Figure D-1	Speed and occupancy values for the M56 J2 (2 lanes) .....	262
Figure D-2	Speed and occupancy values for the M60 J2 (3 lanes) .....	263
Figure D-3	Speed and occupancy values for the M6 J23 (3 lanes) .....	264
Figure E-1	Testing of the model stability .....	265
Figure E-2	Testing the model behaviour according to the following distance .....	266

## Acknowledgements

I would like to thank my supervisor *Dr. Saad Yousif* for his support and guidance during the study. I am grateful for his encouragement which gave me confidence about my work.

The financial support of the Ministry of Higher Education and Scientific Research, Iraq, is gratefully acknowledged. Thanks to the staff of the Iraqi cultural department in London for their support.

Thanks to the staff of the School of Computing, Science and Engineering (CSE) and especially to Mr. Ralph Henson and Prof. Miklas Scholz for their support during this research.

Thanks to the UK Highway Agency for providing an access for the Motorway Incident Detection and Automatic Signalling data (MIDAS).

Thanks to Prof. Eddie Wilson (Formally in Bristol University and now in Southampton University) for providing the individual vehicles raw data from the M25 and the M42 motorway sites.

Thanks to J. Hayden and her colleagues from Atkins Manchester for providing some of the data relating to the operation of ramp metering in the UK.

Thanks to Mr Duncan Bottrill and his colleagues from the technical staff in the School of Computing, Science and Engineering for his help in providing access to a series of PCs that reduced the time of the study.

I would like also to thank Richard Adams for his help during the data collection process.

Thanks to all my friends in the School of Computing, Science and Engineering for their valuable help and support.

## Declaration

Some parts of the work presented in the thesis have been published in the following articles and conferences:

- Al-Obaedi, J. and Yousif, S. (2009a) 'Examining the limitations for visual angle-car following models', *UTSG 41<sup>st</sup> annual conference*, UCL.
- Al-Obaedi, J. and Yousif, S. (2009b) 'The use of visual angle in car following traffic micro-simulation models', *9<sup>th</sup> International Postgraduate Research Conference (IPGRC)*, (ISBN: 978-1-905732-64-7), pp 533-545. *Awarded as the best paper in the conference.*
- Al-Obaedi, J. (2009) 'Calibration of visual angle car following model based on real site traffic data', *Proceeding of Salford Postgraduate Annual Research Conference (SPARC)*, (ISBN: 978-1-905732-88-3), pp 45-55.
- Al-Obaedi, J. and Yousif, S. (2010) 'Testing visual angle-car following models using different sets of data', *UTSG 42 annual conference*, Plymouth University.
- Al-Obaedi, J. and Yousif, S. (2010) 'Estimation of critical occupancy values for UK motorways from traffic loop detectors', *Proceeding of Salford Postgraduate Annual Research Conference (SPARC)*, pp. 22-33.
- Yousif, S. and Al-Obaedi, J. (2011) 'Modelling factors influencing the capacity of motorway merge sections controlled by ramp metering', *TRB 6th International Symposium on Highway Capacity and Quality of Service*, Stockholm, Sweden, *Procedia Social and Behavioral Sciences*, vol. 16, pp 172-183.
- Yousif, S. and Al-Obaedi, J. (2011) 'Close following behaviour: Testing visual angle car following models using various sets of data', *Transportation Research: F*, 14(2), pp 96-110.
- Al-Obaedi, J. (2011) 'Development of traffic micro-simulation model for motorway merges and ramp metering', *UTSG 43 annual conference*, Open University.
- Al-Obaedi, J. and Yousif, S. (2011) 'Micro-simulation model for motorway merges with ramp metering controls', Accepted for publication in *IEEE Transactions on Intelligent Transport System*, DOI: 10.1109/TITS.2011.2169792.

## Dedication

- To my *god*
- To my *father*, he is supporting me even from his grave
- To my *mother*, she has never forgotten me in her prayers
- To my *wife*, my daughter (*Tuqa*) and my son (*Aliridha*).....
- To my *brothers* and *sisters*.....

## Abbreviations

AD-ALINEA:	ADaptive ALINEA
ALINEA:	Asservissement LINéaire d'Entrée Autoroutière
ANCONA:	Congested pattern algorithm
AU-ALINEA:	Adaptive Upstream ALINEA
CARSIM:	CAR following SIMulation model
C-C:	Car following a Car
CF:	Car Following
CFR:	Car Following Rules
C-H:	Car following a Heavy goods vehicle
CONV:	Control variable (%)
CORSIM:	CORnell microSIMulation Model
D-C:	Demand Capacity
DLC:	Discretionary Lane Changing
DRACULA:	Dynamic Route Assignment Combining User Learning and microsimulAtion
DRT:	Driver's Reaction Time
DRTF:	Driver's Reaction Time Factor
EOAL:	End Of the Auxiliary Lane
FHWA:	Federal Highway Administration of America
FL-ALINEA:	FLow ALINEA
FLC:	Frequency of Lane Changes
FORTAN:	FORmula TRANslating System
GHR:	Gazis-Herman-Rothery
H-C:	Heavy goods vehicle following a Car
HCM:	Highway Capacity Manual
HGVs:	Heavy Goods Vehicles
H-H:	Heavy goods vehicle following a Heavy goods vehicle
ITE:	Institute of Transportation Engineering
IVD:	Individual Vehicles' raw Data
JND:	Just Noticeable Difference
K-S:	Kolmogorov-Smirnov
LC:	Lane Changing
LCR:	Lane Changing Restrictions
MALINEA:	Modified ALINEA
METANET:	A macroscopic simulation program for motorway networks
MIDAS:	Motorway Incident Detection and Automatic Signalling
MITSIM:	MIcroscopic Traffic SIMulator
MLC:	Mandatory Lane Changing
PARAMICS:	PARAllel MICroscopic Simulation
PCE:	Passenger Car Equivalency factor
pcu:	Passenger Car Units
PI-ALINEA:	Proportional-Integral ALINEA
QOD:	Queue Override loop Detectors
QOS, QOSs:	Queue Override Strategy, Queue Override Strategies
RM:	Ramp Metering
RMPS:	Ramp Metering Pilot Scheme
RMSE:	Root Mean Square Error
RMSEP:	Root Mean Square Error Percentage
SATMS:	Semi Actuated Metering System
TTS:	Total Time Spent
TTSM:	Total Time Spent for Motorway Traffic
TTSR:	Total Time Spent for Ramp traffic
UF-ALINEA:	Upstream Flow ALINEA
UP-ALINEA:	UPstream ALINEA
VISSIM:	VISual SIMulation



## Symbols

- $\alpha$ : Calibration parameter for lead and lag gaps  
 $\emptyset$ : Proportion of restrained vehicles  
 $\sigma$ : Standard deviation  
 $\Theta$ : Visual angle (rad/sec)  
 $\Delta t$ : Scanning time (sec)  
A: Slope of the curve relating to the downstream and upstream occupancies  
 $a_1$  to  $a_3$ : Acceleration rates used in CARSIM  
 $a_C$ : Acceleration of the follower ( $m/sec^2$ )  
 $a_{C1}$ : Acceleration required to reach the desired speed ( $m/sec^2$ )  
 $a_{C2}$ : Acceleration required to keep the desired spacing ( $m/sec^2$ )  
 $a_{C3}$ : Acceleration for non collision criteria ( $m/sec^2$ )  
 $a_{C4}$ : Acceleration from a stationary condition ( $m/sec^2$ )  
 $a_{C5}, a_{C6}$ : Normal and maximum acceleration rates of the follower ( $m/sec^2$ )  
 $a_{C7}, a_{C8}$ : Normal and maximum deceleration rates of the follower ( $m/sec^2$ )  
 $acc_1$  to  $acc_5$ : Acceleration rates used in PARAMICS  
buf: Minimum separation distance between vehicles at stationary conditions (m)  
 $d(k-1)$ : Demand flow entering the ramp in the previous time interval (veh/hr)  
D: Distance ahead of a lane changer vehicle, in considering the effect of vehicles in other lanes, used in discretionary lane changing rules (m)  
D1, D2, D3: Locations of motorway's downstream detectors  
 $D_{cr}$ : Critical difference in the cumulative distributions between two samples  
 $D_{max}$ : Maximum difference in the cumulative distributions between two samples  
DRT<sub>C</sub>: Driver's reaction time of vehicle C (sec)  
 $DV_C$ : Desired speed of vehicle C  
g: Effective vehicle length (m)  
 $g_{min}$ : Minimum gap  
h: Headway (sec)  
H: Space headway (m)  
 $h'$ : Average headway of successive vehicles crossing the stop line during green (sec)  
h1: Headway of free following vehicle (sec)  
h2: Headway of restrained vehicle (sec)  
HGVs%: Proportion of Heavy Goods Vehicles  
 $h_{min}$ : Average minimum headway (sec)  
 $K_R, K_P, K_{R2}$ : Regulator parameters  
 $L_A$ : Length of auxiliary lane (m)  
 $L_L$ : Length of leader (m)  
M: Merge ratio  
 $m'$ : Mean headway parameter of the lognormal distribution  
md: Maximum deceleration rate ( $m/sec^2$ )  
Minlag: Minimum lag gap (sec)  
Minlead: Minimum lead gap (sec)  
N: Number of vehicles per lane that would be released during the cycle (veh)  
nd: Normal deceleration rate ( $m/sec^2$ )  
 $NP_C$ : New position of vehicle C (m)  
 $NP_L$ : Anticipated new position of the leader (m)  
 $NV_C$ : New speed of vehicle (C) (km/hr)  
 $O_{cr}$ : Critical occupancy (%)  
 $O_{des}$ : Desired occupancy (%)  
 $O_f$ : Filtered occupancy (%)  
 $O_{in}$ : Motorway upstream occupancy (%)  
 $O_{out}$ : Motorway downstream occupancy (%)  
P: Period of time used to shutdown the RM for the ANCONA algorithm

$P_C$ : Position of vehicle C (m)  
 $PD$ : Proportion of drivers prefer to return to their original lanes after overtaking (%)  
 $P_{H1}, P_{H2}, P_{H3}$ : Proportions of HGVs in lane1, lane2 and lane 3  
 $q^*$ : Flow rate of free flowing vehicles  
 $q$ : Flow rate  
 $q_0$ : Flow rate at zero percentage of HGVs (veh/hr)  
 $q_{cap}$ : Motorway capacity (veh/hr)  
 $q_h$ : Flow rate of HGVs (veh/hr)  
 $q_{in}$ : Motorway upstream flow (veh/hr)  
 $q_{max}$ : Maximum metering rate (veh/hr)  
 $q_{out}$ : Motorway downstream flow (veh/hr)  
 $Q_r$ : Merging capacity (veh/hr)  
 $q_r$ : Metering rate (veh/hr)  
 $q_{ramp}$ : Ramp flow rate (veh/hr)  
 $q_{rl}$ : Metering rate per lane (veh/hr)  
 $q_{rmin}$ : Minimum metering rate (veh/hr)  
 $r$ : Coefficient of correlation  
 $r'$ : Minimum rate to prevent queue build up  
 $r^2$ : Coefficient of determination  
 $Ran, R_i, R_j$ : Random number [0-1.0]  
 $ROC$ : Rate of change of flow to occupancy values  
 $S.D$ : Stopping distance (m)  
 $S$ : Saturation flow rate (veh/hr)  
 $s'$ : Mean standard deviation of the lognormal distribution  
 $S_f$ : Speed of the follower (m/sec)  
 $S_{min}$ : Minimum separation distance between vehicles plus the leading vehicle length (m)  
 $S_{p1}$ : Speed used in the ANCONA algorithm  
 $S_{p2}$ : Speed used in the ANCONA modified algorithms  
 $T.T$ : Travel time  
 $T1$ : Average headway of restrained vehicles (sec)  
 $T2$ : Average headway of free vehicles (sec)  
 $U(U^*)$ : Theil's inequality coefficient  
 $U1, U2$ : Locations of motorway's upstream detectors  
 $U_c$ : Theil's inequality coefficient to measure the unsystematic error  
 $U_m$ : Theil's inequality coefficient to measure the error in the mean  
 $U_s$ : Theil's inequality coefficient to measure the error in the standard deviation  
 $V_C$ : Current speed of vehicle C  
 $V_{cr}$ : Critical speed (km/hr)  
 $V_u$ : Upstream speed (km/hr)  
 $W(k)$ : Ramp queue length (veh) at time interval k  
 $W$ : Width of the leading vehicle (m)  
 $W_{max}$ : Maximum allowable queue length (veh)  
 $x_i$ : Actual data at time interval i  
 $y_i$ : Simulated data at time interval i

## Abstract

This thesis focuses on the development of a micro-simulation model for motorway merge sections. The aim is to study the effectiveness of applying some traffic management controls and particularly focuses on applying ramp metering (RM) systems.

The new model has been developed based on car-following, lane changing and gap acceptance rules. The model considered the multi-decisions undertaken by merging traffic when a driver, for example, accepts the lead gap and rejects the lag gap. The cooperative nature of drivers is also considered where motorway drivers allow others to merge in front of them either by decelerating or shifting to other lanes (yielding) in the vicinity of motorway merge sections. Video recordings, as well as data from the Motorway Incident Detection and Automatic Signalling (MIDAS) were obtained from a selection of sites. The data was used in the verification, calibration and validation processes of the developed model. Other main sources of information include more than 4 million cases of successive vehicles taken from UK motorway sites. These cases were analysed to study the effect of vehicle types on the following behaviour for drivers. The main finding is that there is no evidence that the average spacing between successive vehicles is significantly affected by the type of leading vehicle.

Different RM algorithms have been integrated within the developed model. The results of testing the effectiveness of RM controls using the developed model reveal the benefits of RM in reducing time spent by motorway traffic (TTSM) but it significantly increases the time spent by the merging traffic (TTSM). The overall benefits of implementing RM in reducing total time spent (TTS) is limited to situations where the sum of motorway and merge flows exceeds the capacity of the downstream section. Other issues related to RM design and effectiveness have been tested such as the effects of having different durations for peak periods, finding the optimum parameters for each algorithm, the effect of ramp length (storage area) and the effect of RM signals position. The results suggest that RM is very efficient when implemented for short peak periods (e.g. less than 30 minutes). The effectiveness of RM in decreasing the travel time for motorway traffic is increased with an increasing ramp length but with a significant increase in ramp traffic delay. No significant effect is obtained from altering the ramp signals' position.

Other tests include the use of other types of traffic management controls (e.g. applying different speed limits and lane changing restrictions (LCR) at the approach to merge sections). No significant improvements were obtained from testing different speed limit values. The results suggest that LCR could reduce travel time for motorway traffic. However, there are other practical considerations which need to be addressed before this could be recommended.

---

## CHAPTER ONE : INTRODUCTION

### 1.1. Background

Merging traffic involves combining two or more traffic streams so that they are travelling together. On motorways, the merging process considers joining traffic coming from slip roads (i.e. on-ramps) onto the main motorway. It is a complicated process since it depends on several factors such as driver behaviour, traffic flows and the geometry of the section. Drivers from the ramp usually merge directly if the available gaps are accepted. If not, they may accelerate/decelerate in order to create safe merging opportunities (Kou and Machemehl, 1997a, Zheng, 2003 and Hidas, 2005).

Traffic congestion is mainly produced when the sum of motorway upstream traffic and the merging traffic exceeds the capacity of the motorway section. The onset of congestion results in longer journey time and also adversely affects the environment as a result of increasing fuel consumption. To deal with motorway traffic congestion, several traffic management controls have been suggested (such as ramp metering (RM)). RM involves installing traffic signals on slip roads to control the rate of vehicles entering the motorway section. This has been applied in the USA since 1963 and since then has been deployed in most European countries. Other traffic management controls such as using speed limits and using the hard shoulder lane for running traffic have also been increasingly used. Consequently, there is a focus in new research on the efficiency of using traffic signals to control main motorway traffic (Carlson *et al.*, 2010).

Application of these traffic management control algorithms requires calibration first to find the optimum parameters for the selected algorithm. Using on-site trials needs extensive time and funding resources and also is not be possible without causing obstruction and disturbance to moving traffic.

Traffic simulation models have been increasingly used in studying and suggesting solutions for traffic problems. Such simulation models provide the opportunity to evaluate traffic controls and design strategies without committing a lot of expensive resources (including time) which are necessary to implement alternative strategies in the field (Clark and Daigle, 1997). According to Kotsialos and Papageorgiou (2001), these models can be used for estimation, prediction and control related tasks for the traffic process and therefore

these simulation models can help in analysing everyday traffic management needs by looking at problems such as congestion and identifying their sources.

## 1.2. Aim and objectives

The aim of this work is to develop a new traffic simulation model to investigate the effectiveness of ramp metering controls in reducing travel time for different flow rates. The objectives of the study are:

- Developing a traffic micro-simulation model for merge traffic which should be capable of taking into consideration the limitations of previous models using the existing rules and algorithms and applying the necessary modifications as required.
- Testing the developed car following, lane changing and the merging rules as well as the whole simulation model using real traffic data.
- Using real traffic data to study the effect of vehicle types on following distance behaviour. This will help in selecting a suitable algorithm for car following to be used in developing the simulation model.
- Using the model in testing factors which can affect the merge section capacity including the effect of heavy good vehicles and the effect of the cooperative behaviour of drivers.
- Integrating different RM algorithms within the logic of the developed model and testing the effectiveness of applying such algorithms.
- Finding the optimum parameters for triggering RM controls for each specific algorithm such as the optimum position of the traffic loop detectors and the critical occupancy.
- Testing the effect of on-ramp storage capacity on overall performance of RM.
- Testing other possible scenarios in order to improve the merging capacity such as applying speed limit controls and lane changing restrictions.

## 1.3. Thesis outline

- Chapter one presents a brief introduction on traffic congestion that is produced on merge sections, RM and using of simulation models. The aim and objectives were also introduced.

- Chapter two presents a review of literature relating to simulation models and the rules used for car following, lane changing and merging.
- Chapter three focuses on the RM algorithms and the relevant evaluation studies for RM controls.
- Chapter four presents the data that have been collected and analysed during this study for some of the parameters relating to traffic characteristics on UK motorway sections.
- Chapter five explains the developed simulation model and focuses on the rules used for car-following, lane changing and merging. The modelling of RM controls is also presented in the chapter.
- Chapter six deals with the process of the verification, calibration and validation of parts of the model (i.e. the car following, lane changing and merging rules) as well as for the whole simulation model using real traffic data from various sites and resources.
- Chapter seven presents the applications conducted using the developed model without the use of RM controls.
- Chapter eight presents the applications relating to the use of RM controls that have been conducted using the developed simulation model.
- Chapter nine presents the conclusions and suggests some possible expansions that could be considered for future research.

---

## CHAPTER TWO : TRAFFIC SIMULATION MODELS

### 2.1. Introduction

Traffic simulation models play a major role in allowing traffic engineers to evaluate complex traffic situations. Such models help in suggesting solutions and recommending alternative scenarios without committing a lot of expensive resources which are necessary to implement alternative strategies in the field (Hidas, 2005). This chapter briefly defines the main types of simulation models and then concentrates on the rules that are applied in microscopic models. The main limitations in the existing simulation models are described at the end of this chapter.

### 2.2. Simulation approaches

Based on the level as to how simulation models describe traffic behaviour, models are classified into macroscopic, mesoscopic and microscopic models (ITE, 2010).

- Macroscopic models describe traffic characteristics based on average parameters such as flow, speed and density by assuming that traffic flow behaves as fluid without representing the interactions between individual vehicles (Skabardonis, 1981).
- Mesoscopic models describe traffic in much more detail than that described in macroscopic models by considering the individual vehicles in groups or cells; however these models ignore the interaction of vehicles in each individual group (Burghout, 2004).
- Microscopic models describe the traffic at a detailed level where specific rules are applied to represent the interactions between individual vehicles such as those rules used for longitudinal movements (i.e. car following) and lateral movements (i.e. lane changing). While the calibration process is not as straightforward as in macroscopic level, micro-simulation models are more efficient in studying complicated situations such as merge sections (Burghout *et al.*, 2005).

The ITE (2010) suggested that microscopic models are not efficient in testing long sections (such as hundreds of miles) since such models require high numbers of computation processes which increase the simulation time. Burghout (2004) and Burghout *et al.* (2005) discussed the advantages and limitations of these three simulation models. They suggested that macroscopic and mesoscopic models are easy to calibrate, but these models are only

capable of simulating situations where the interaction between vehicles are minimal. The macroscopic models are not sensitive enough for geometric factors such as the length of auxiliary (acceleration) lane in the merge area. It is also reported that there is a difficulty in integrating traffic loop detectors within mesoscopic and macroscopic models since these models could not accurately calculate the position of vehicles in the system. In addition, both mesoscopic and macroscopic models are not capable of simulating sections where the adaptive traffic signal is needed such as those used in RM controls.

Regardless of the difficulty of the calibration of microscopic models, there is an agreement about the ability of such an approach to simulate different complicated situations. This is also represented by the increasing use of such models over the last 30 years. A microscopic approach is adopted in this study and therefore the next sections in this chapter focus on explaining the main rules in this approach.

### **2.3. Micro-simulation modelling process**

A micro-simulation model consists of a combination of sub-models called car following (CF), lane changing (LC) and gap acceptance. CF models calculate the acceleration/deceleration rates used in updating the longitudinal positions of vehicles. LC models describe the lateral movements of vehicles based on traffic conditions in the current and the target lanes. The gap acceptance models are used to check the feasibility of executing a lane change.

#### **2.3.1. Car following (CF) models**

Car-following (CF) models describe the relationship between pairs of vehicles in a single lane. This relationship is represented by several mathematical models which basically describe the effect of the leading vehicle on its follower. The reaction of the follower is expressed by his/her acceleration or deceleration depending mainly on the leader's speed and the relative distance between the two vehicles. Previous research has suggested different CF models; below are the main types of these models as classified by Brackstone and McDonald (1999).

##### *a. Gazis Herman Rothery (GHR) model*

This model represents the earlier CF model which was formulated in 1958 at the General Motors' Research Laboratory in Detroit. According to the model, the acceleration of the



follower is based on the relative velocity, the relative spacing and the following vehicle's velocity as shown in the following equation:

$$a_C = c_1(V_C)^{c_2} \frac{V_C - V_L}{(P_L - L_L - P_C)^{c_3}} \quad \text{Equation 2-1}$$

where,

- $a_C$  is acceleration (m/sec<sup>2</sup>) of the follower (C),
- $c_1, c_2, c_3$  are model parameters,
- $L_L$  is the length (m) of the leading vehicle (L),
- $P_C, P_L$  are the positions (m) of the follower (C) and the leader (L), respectively, and
- $V_C$  and  $V_L$  are the speeds (m/sec) of the follower and the leader, respectively.

Brackstone and McDonald (1999) provided detailed information regarding the choice of the model parameters (i.e.  $c_1, c_2$  and  $c_3$ ) and stated that the GHR model was being used less frequently because of the large number of contradictory findings for the values used to represent these parameters. Also, Gipps (1981) reported that the model parameters have no explicit connection with drivers' or vehicles' characteristics. MITSIM (Yang and Koutsopoulos, 1996) is an example of a simulation model that used such a type of CF model. It should be noted that MITSIM is widely used in the simulation studies in the USA (see for example, Ahmed (1999), Toledo *et al.* (2003) and Choudhury (2007)).

#### *b. Collision avoidance models*

According to these models, a safe separation distance is assumed to be maintained between the follower and the leader. Gipps (1981) introduced a CF model assuming that the follower selects his/her speed to ensure that he/she can bring his/her vehicle to a safe stop should the vehicle ahead came to a sudden stop. The model by Gipps (1981) used an additional safety margin of error which is equal to half of the brake reaction time by assuming that a driver makes allowance for a possible additional delay before reacting to the vehicle ahead. The model by Gipps has been used in many micro-simulation models such as the AIMSUN (Barceló and Casas, 2002) and DRACULA (Liu *et al.*, 1995) models.

An additional example of presenting safe conditions in CF models is a CAR following SIMulation model (CARSIM) which has been developed by Benekohal (1986) to simulate traffic in both normal and stop and go conditions. The acceleration rate of the follower according to CARSIM (Benekohal, 1986) is mainly the minimum of the rate required to reach the vehicle's desired speed ( $a_1$ , using Equation 2-2), the engine capability of the vehicle ( $a_2$ ), and the acceleration rate required to maintain the desired headway and the safe spacing ( $a_3$ , using Equation 2-3). The model provides a minimum distance between the leader and the follower equivalent to a driver's reaction time.

The CARSIM model has been used in many micro-simulation applications. For example, Yousif (1993) developed a model based on similar assumptions to those used in CARSIM in order to study the effect of lane changing on traffic operation for dual carriageway roads with roadworks. Wu and McDonald (1995) used CARSIM in developing a simulation model to represent the interactions between light rail transit (LRT) and road vehicles at intersections. Goodman (2001) and Purnawan (2005) used CARSIM when the former developed a model to predict the noise of road traffic and the latter used micro-simulation in evaluating the effect of on-street parking facilities on delay and capacity.

$$a_1 = \frac{DV_C - V_C}{\Delta t} \quad \text{Equation 2-2}$$

$$P_L - V_C \Delta t + 0.5 a_3 \Delta t^2 - S_{\min} \geq \max \left\{ \begin{array}{l} (V_C + a_3 \Delta t) DRT_C \\ (V_C + a_3 \Delta t) DRT_C + \frac{(V_C + a_3 \Delta t)^2}{2 md_C} - \frac{V_L^2}{2 md_L} \end{array} \right. \quad \text{Equation 2-3}$$

where,

$\Delta t$  is the scanning time (sec).

$DRT_C$  is the driver's reaction time of the follower (sec).

$DV_C$  is the desired speed of the follower (m/sec),

$md_C$  is the maximum deceleration rate for the follower,

$md_L$  is the maximum deceleration rate for the leader, and

$S_{\min}$  is the minimum separation between vehicles at stopping conditions (buf) plus leading vehicle's length (m).

### c. Desired spacing models

According to these models, the acceleration of the follower is a function of both relative distance and relative speed between the leader and follower. Also, it is a function of the desired following distance (time spacing) the follower wishes to maintain. The desired distance is a function of the speed of the follower. Panwai and Dia (2005) reported that desired spacing models could present a good fit to observed data. However, they stated that the main difficulty is with the calibration of the constant parameters used for each individual site.

### d. Psychophysical models

These models consider the ability of the human perception of motion which assumes that a driver will accelerate or decelerate depending on a perceived threshold value. Basically, the perceived threshold is related to the difference in speeds or spacing between pairs of vehicles.

Visual angle models are described by researchers such as Brackstone and McDonald (1999) and Panwai and Dia (2005) as one type of psychophysical (or action point models). Michaels (1963) observed that the detection of relative velocity depends on the rate of change of angular motion of an image across the retina of the eyes of the follower. The visual angle ( $\theta$ ) as shown in Figure 2-1 and its rate of change or angular velocity ( $d\theta/dt$ ) are calculated as estimated using Equations 2-4 and 2-5, respectively. Once the absolute value for this threshold ( $d\theta/dt$ ) is exceeded, a driver notices that his/her speed is different from that of the vehicle ahead and reacts with an acceleration/deceleration opposite in sign to that of  $d\theta/dt$  (Ferrari, 1989).

$$\theta = 2 \tan^{-1} \left( \frac{w}{2(P_L - L_L - P_C)} \right) \quad \text{Equation 2-4}$$

$$\frac{d\theta}{dt} = \frac{-w(V_L - V_C)}{(P_L - L_L - P_C)^2} \quad \text{Equation 2-5}$$

where,

$L_L$  is the length of the leading vehicle (m), and

$w$  is the width of the leading vehicle (m).

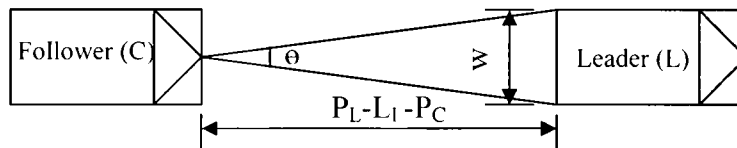

Figure 2-1 The visual angle  $\theta$

According to Michaels (1963), the visual angle threshold ranges between  $3 \times 10^{-4}$  and  $10^{-3}$  rad/sec and it is reasonable to use  $6 \times 10^{-4}$  rad/sec as an average value. Fox and Lehman (1967) described a CF model based on the visual angle concept using a base value of the threshold as used by Michaels (i.e.  $6 \times 10^{-4}$  rad/sec). Ferrari (1989) presented a traffic simulation model for motorway conditions assuming that the angular velocity threshold is identical for all drivers. He used a value of  $3 \times 10^{-4}$  rad/sec with a minimum time gap between two successive vehicles of 1 second.

Hoffman and Mortimer (1994 and 1996) carried out a study to scale the relative velocity between vehicles. They reported that when the rate of change of the subtended angle of a lead vehicle exceeds the threshold value (which is  $3 \times 10^{-3}$  rad/sec), drivers have the information available to subjectively scale the relative motion between the two vehicles and drivers were able to give a reasonable estimate of time to collision.

There is another threshold in the psychophysical models. This threshold is particularly relevant to close distance (spacing) headways where speed differences are always likely to be below the angular velocity threshold (Brackstone and McDonald, 1999). This is related to the well-known Weber's law (according to this law, any change would be noticeable if it exceeds the just noticeable difference (JND) which is about 10%). Therefore, a driver chooses to accelerate or decelerate in the case where the spacing is changed by a value of 10% of their desired spacing.

It should be noted here that some work has been carried out during this study on the use of visual angle CF models. The findings that were reported by Yousif and Al-Obaedi (2011) suggested the ability of the visual angle model to represent the variations in drivers' reaction time with respect to traffic conditions. However, the study suggested that based on a large database of data from UK motorway sites (as will be explained later in this thesis), the average spacing between the cases of car following car (C-C) and car following heavy goods vehicle (C-H) were not significantly different. This is in disagreement with the assumptions of the visual angle model which assumes that drivers leave a higher spacing if they follow heavy good vehicles rather than if they follow small cars.

VISSIM (Wiedemann, 1974) and PARAMICS (Duncan, 1995) are examples of the micro-simulation models that use the psychophysical CF approach. The car following model in PARAMICS is divided into five phases based on the differences in speeds and spacing with respect to the leading vehicle ahead. These phases and their corresponding acceleration/deceleration rates (acc1 to acc5) are described below and shown in [www.paramics-online.com](http://www.paramics-online.com).

Phase 1: This represents the situation where the headway of the follower (C) becomes less than that desired.

$$\text{acc}_1 = k_2(V_L - V_C) \quad \text{Equation 2-6}$$

Phase 2: This represents the situation where the leading vehicle is pulling away from the follower.

$$\text{acc}_2 = k_2(V_L - V_C) + k_1 \frac{(P_L - L_L - P_C) - t}{t} \quad \text{Equation 2-7}$$

$$t = \frac{h^2(V_L - V_C)^2}{P_L - L_L - P_C} \quad \text{Equation 2-8}$$

Phase 3: This represents the situation where there is a constant separation with the leading vehicle.

$$\text{acc}_3 = k_1 \left( \frac{(P_L - L_L - P_c) - 2}{P_L - L_L - P_c} \right) - \left( \frac{(V_L - V_c)^2}{(P_L - L_L - P_c) - t} \right) \quad \text{Equation 2-9}$$

Phase 4: This represents the situation where the spacing between the two vehicles is close enough so as to cause the danger of collision.

$$\text{acc}_4 = k_3 \quad \text{Equation 2-10}$$

Phase 5: This represents the situation where the vehicle ahead is accelerating and the distance between the two vehicles is higher than the required stopping distance.

$$\text{acc}_5 = \text{maximum acceleration} \quad \text{Equation 2-11}$$

where,

$h$  is the time headway (sec) of the follower, and

$k_1$ ,  $k_2$  and  $k_3$  are the calibration parameters with units of  $\text{m}/\text{sec}^2$ ,  $1/\text{sec}$  and  $\text{m}/\text{sec}^2$ , respectively.

It should be noted here that the units in the original document (i.e. [www.paramics-online.com](http://www.paramics-online.com)) for  $k_1$  (which was  $1/\text{sec}^2$ ) were not correct and instead this should be  $\text{m}/\text{sec}^2$ . The said document also suggests that there are still some technical details which have not been reported for commercial reasons. Therefore, it is recommended that one should take extreme care in trying to use these formulae.

#### e. Other CF models

There have been several other attempts by researchers to model CF using alternative methods. The fuzzy system of the CF model describes a follower's response to the change of relative speed and headway to that of the leader according to his/her own free speed and desired safe following distance. The model divides the variables such as speed and headway into a number of overlapping sets associating each one with a particular term such as 'close' and 'very close' (Brackstone and McDonald, 1999).

Cellular automata models represent simple microscopic models which are straightforward with a logic that usually consists of a few integer operations. According to Bham and Benekohal (2004), Nagel (1998) reported that cellular automata models do not have realistic drivers and vehicle behaviour models. In order to reduce the computational process in the simulation model, Bham and Benekohal (2004) developed a cell based traffic simulation model called CELLSIM using a dual-regime constant acceleration model and two deceleration models. Space in the model was divided in cells of 1 ft (0.31m).

**2.3.2. Lane changing (LC) models**

LC models describe the situations where drivers may wish to change lanes. The decision for making a lane change (desirability) depends on many factors such as traffic speed and the densities in both current and destination lanes, approaching a ramp terminal, approaching a ramp merging area and other factors. The feasibility of executing of a lane change is based on many factors such as the benefit obtained from executing a lane change and the availability of sufficient lead and lag gaps (see Figure 2-2) in a target lane. The availability of such gaps is usually controlled by a gap acceptance model. The general structure for LC models is shown in Figure 2-3 which is applicable for most of the existing LC models (see for example, Gipps (1986) and Choudhury (2007)). However, the specific details as to the desirability and feasibility assumptions used in such models may differ from one another as described below.

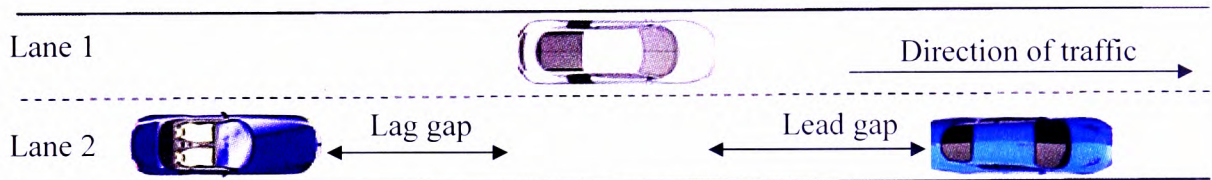

Figure 2-2 Illustration of lead and lag gaps

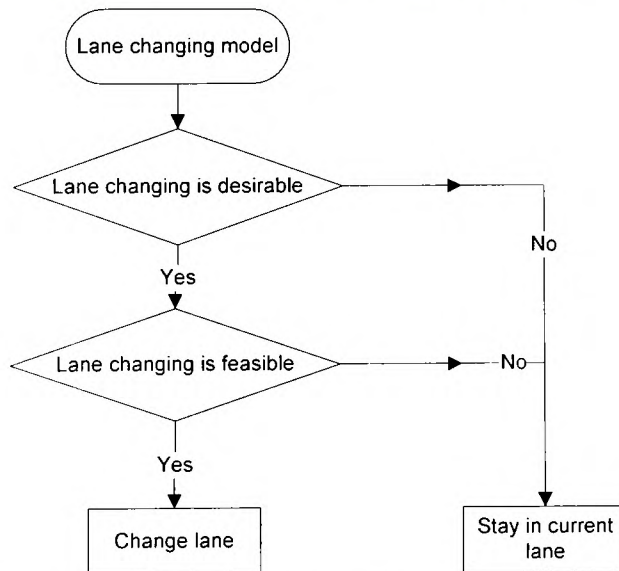

Figure 2-3 The general structure of the lane changing model

Many LC models have been developed since 1978 (Choudhury, 2007). In most of these models, LC is classified into discretionary (DLC) and mandatory LC (MLC) (Ahmed, 1999, Toledo *et al.*, 2003 and Choudhury, 2007). DLC represents the cases where drivers are not forced to change their lanes. In such cases, the main reason for a lane change is to enhance their speeds (Skabardonis, 1981 and Sultan and

McDonald, 2001) or in order to return to their original lanes after the overtaking process (Ferrari, 1989). MLC happens in cases where drivers are forced to change lanes due to, for example, merging from a slip road to join motorway traffic.

Further classifications for LC could be related to the size of the accepted gap. These are forced and unforced “free” LC. Forced LC happens when the lane changer causes speed reduction for the lag vehicle in the destination lane within a short time. Free LC occurs when the process of a lane change does not involve speed reduction for either the lane changer or the new follower (i.e. lag vehicle).

One of the earlier LC models at a microscopic level was introduced by Sparmann (1979). Psychophysical thresholds for relative speed and relative spacing were used to state if a vehicle is impeded by its leader with a consideration of movement toward faster and slower lanes.

Gipps (1986) developed a rule based model which defined the possibility, necessity and desirability of a lane change. For MLC, it was assumed that the maximum deceleration rate for a driver increases as he/she approaches his/her intended turn. This assumption was to reflect the driver’s willingness to brake harder and accept smaller gaps. For DLC, a lane change toward higher speed lanes is feasible if the speed of the new leader is higher by a value of 3.6 km/hr and there are sufficient lead and lag gaps. It was also assumed that a driver will not change to a slower lane if the speed of the new leader is lower by a value of 0.1 m/sec.

Yousif (1993) developed a model for both normal and roadworks conditions. It was assumed that a driver will desire to change if he/she is impeded by a slower vehicle which has a speed less than his/her by a magnitude “R” (in km/hr as described by Ferrari (1989)). The R value is obtained from Equation 2-12. A vehicle may change to a slower speed lane if the follower (in the current lane) is faster by a value of R. The size of the accepted gap was reduced in the situations of MLC. It was assumed that a driver will check his position with the new leader for the next 15 seconds before executing a lane change.

$$R = \frac{1040}{DV_C} \quad \text{Equation 2-12}$$

where  $DV_C$  is the desired speed of vehicle C (km/hr).

In a microscopic traffic simulator (MITSIM), Yang and Koutsopoulos (1996) applied “an impatient factor and a speed indifference factor” in considering D.L.C. The “impatient factor” was used to decide the desirability of a lane change while the “speed indifference

factor” was used to ensure that a lane change would help in increasing the speed of the lane changer. The size of the accepted gap is assumed to be less in MLC than in DLC.

Ahmed (1999), Toledo *et al.* (2003) and Choudhury (2007) developed LC models that were each tested and validated using MITSIMLab. All of these models assumed that a driver can use neighbouring lanes (inside and offside lanes) to enhance his/her speed (see Figure 2-4 for the DLC by Ahmed, 1999). This is not the case in UK motorways where the applied rules, under normal traffic operation, limit overtaking to using the offside lanes only (Highway Code, 2010) rather than undertaking using the inside lane.

Choudhury (2007) developed a LC model which considered the latent plan of a driver when he/she may accept a reduction in his/her speed for a short period, in order to enhance his/her speed later. An example of such a case is when a driver in lane 1 may change to a faster lane (e.g. lane 4) even when the average speeds in lanes 2 and 3 are lower than his/her current speed.

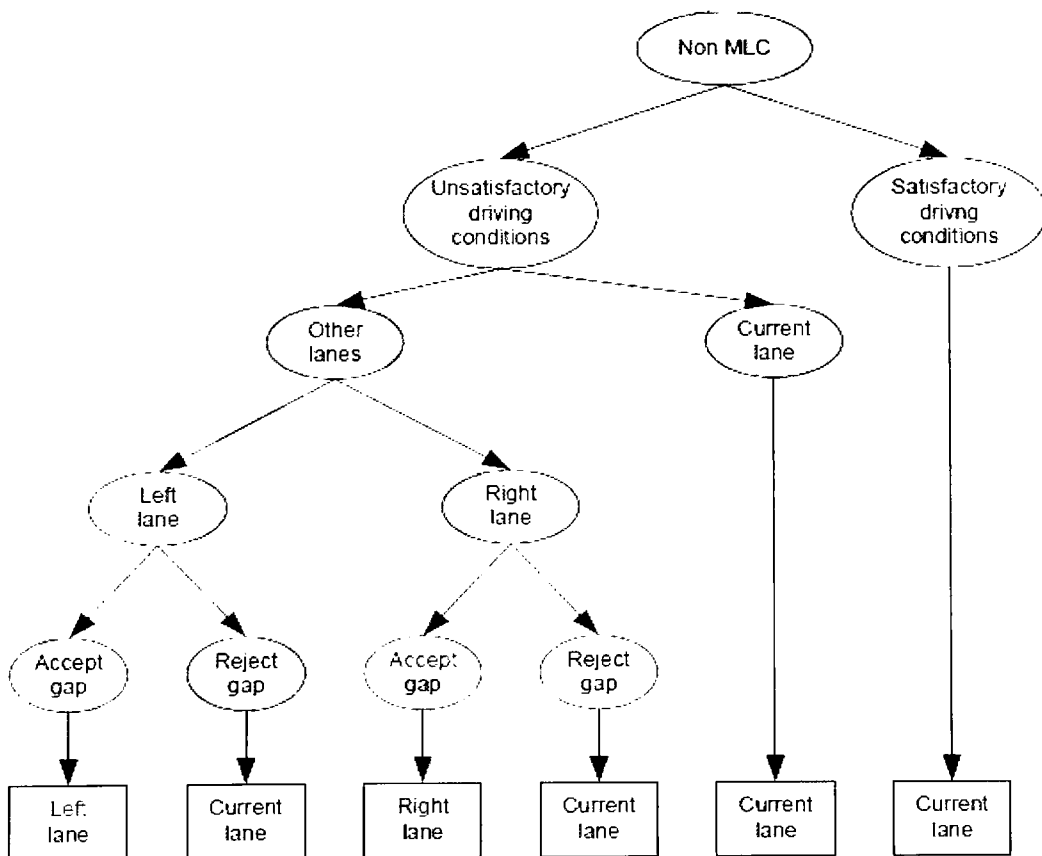

Figure 2-4 DLC proposed by Ahmed (1999)

### 2.3.3. Merging models

Merging models, which are examples of mandatory LC (MLC), describe the interactions that happen between motorway traffic and merge traffic when the latter join a motorway



section. Different merging models have been developed in previous research. Presented below is a critical review of some of these models.

The merging models in the widely used simulation packages such as VISSIM, ALIMSUN and PARAMICS ignore some important interactions between merge and motorway traffic. According to these models, no cooperative (decelerating) behaviour is offered by the motorway traffic. In addition, these models usually give priority to the motorway traffic. Such a priority is not observed from real data according to Hounsell and McDonald (1992) who reported that data taken from many UK motorway sites revealed that observed priority may be in favour of merging traffic.

AIMSUM uses a maximum waiting time for a vehicle before merging after which the vehicle will be deleted from the system (Hidas, 2005). The VISSIM model uses a “waiting time before diffusion” parameter to deal with such cases. A value of 1 second for this parameter was applied by Horowitz *et al.* (2005) when studying the effectiveness of RM.

Zheng (2003) developed a merging model which ignores the cooperative behaviour of drivers. However, he verified the existence of such cooperative behaviour from analysing video recorded data.

Hidas (2005), based on real traffic data, considered three types of merging, namely free, forced and cooperative. The first type is the same as unforced LC as described above. The feasibility of cooperative LC is based on the willingness of the new follower to decelerate based on his/her position and speed with respect to the merger vehicle. The study ignored the effect of LC from the nearest lane to other lanes (i.e. shifting) in order to create gaps for merging traffic.

Wang (2006) developed a model which considered such cooperative nature between drivers on motorway merge sections when the lag driver (in a motorway section) slows down or yields (moving to another lane) in order to help merge traffic coming on from a slip road. Each vehicle on a mainline which is previously assigned to do shifting behaviour (based on binomial distribution) can be easily removed from the system. This assumption suggests that the shifting behaviour in Wang’s model is not related to traffic conditions and also ignores the effect of traffic in other lanes. The model by Wang was designed for a simple geometry consisting of a one lane on-ramp with only the nearest lane of the motorway. The merger vehicle will adjust its speed according to the size of the available gaps on the motorway section. However, the model also removes vehicles from the system once they reach the end of the merging acceleration (auxiliary) lane, and the

probability of a vehicle being removed/deleted increases with the decreasing length of the auxiliary lane. These deletions of vehicles could reach to 20% in some cases. This is not logical since removal of vehicles is not an option and could affect the overall reliability of the results.

Sarvi and Kuwahara (2007) developed a model which considered the cooperative behaviour of drivers in congested situations only. Their model did not consider the condition of ensuring that there were sufficient lead and lag gaps for merging. Instead, they suggested that a lag vehicle (on the motorway section) will follow the merger (on the ramp section) and the latter will follow its new leader (on the motorway section) using a CF rules.

Choudhury (2007) developed a merging model and included within it sequences of decisions made by a merging driver when entering the auxiliary lane. These are normal, cooperative and then forced merging if and when sufficient gaps are not available. Her model ignored the acceleration/deceleration behaviour of the merging vehicle in order to adjust its position with respect to the available lead and lag gaps. Such acceleration/deceleration behaviour was added in the model developed by Choudhury *et al.* (2009). However, such behaviour was only included if a driver failed to execute merging using the above three merging “tactics” (i.e. normal, cooperative and forced). That will affect situations where a merging driver (C) (as shown in Figure 2-5), may prefer to adjust his/her acceleration/deceleration rates earlier depending on the size of the available lead and lag gaps as well as the proximity of the end of the auxiliary lane. For example, in Figure 2-5a, vehicle C may decelerate and merge, while in Figure 2-5b, vehicle C may accelerate sharply and merge without forcing J2 to slow down.

Models developed by Ci *et al.* (2009) and Guan *et al.* (2010) assumed that the merging traffic has no effect on the motorway traffic (i.e. these models ignored the effect of cooperative behaviour amongst drivers).

All the above mentioned microscopic merging models did not consider the “relaxation” process when vehicles C and J2 keep close following behaviour with their leaders within the merging section. Such close following behaviour continues for a relatively short period during and after the merging process (Papageorgiou *et al.* (2008) and Laval and Leclercq (2008)). The existing simulation models made a significant reduction in the size of the accepted gaps without properly dealing with the situations after the merging process.

It is likely that such limitations will affect the capability of these models in dealing with real traffic situations/behavioural issues and therefore, limit their applications and capabilities. This highlights the need for developing a new model to take into consideration such issues, making use of existing rules and algorithms and applying the necessary modifications as required. Therefore, this work focuses on developing a micro-simulation model for merging traffic and then uses the model for further applications such as testing the effectiveness of RM controls.

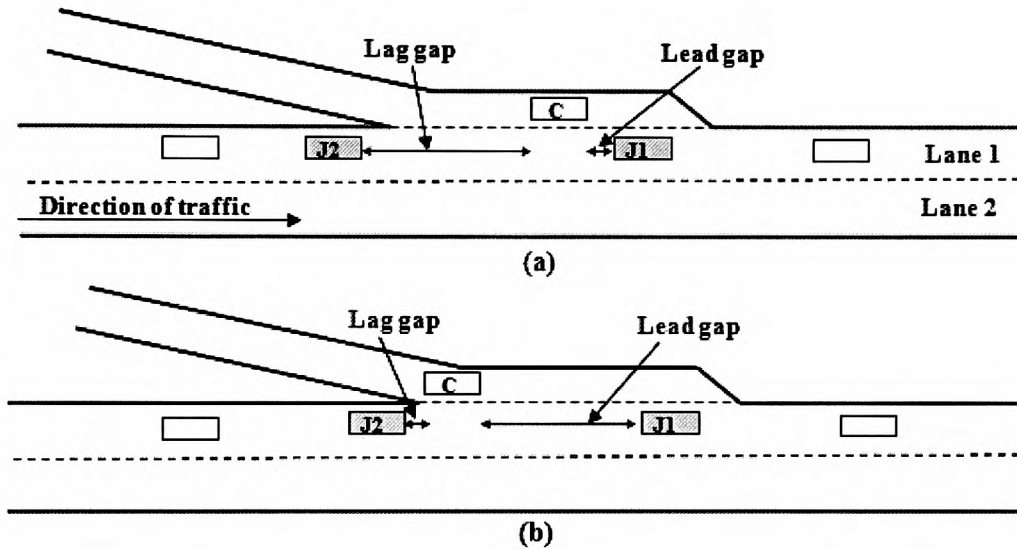

Figure 2-5 Position of the merger with respect to the available gaps

### 2.3.4. Review of gap acceptance models

#### a. *Empirical gap acceptance models*

The possibility of executing LC manoeuvring depends on the availability of sufficient lead and lag gaps in the target lane. The minimum accepted gap is usually defined as a critical gap (Choudhury, 2007). Different gap acceptance models have been developed in previous research. Drew *et al.* (1967) and Miller (1972) suggested some distributions for the size of critical gaps for drivers with a fixed value for each driver at different conditions. Daganzo (1981) suggested a multinomial model to consider the variability between the population of drivers and also within the same driver. Adebisi and Sama (1989) noticed that increasing the delay will result in accepting lower gaps.

For merge traffic, Worrall *et al.* (1967) suggested that the lag gap for individual drivers follows the step function with respect to the relative speed ( $R_v$ ) between the merger and its new follower on a motorway, as shown in Table 2-1.

Kou and Mathemehl (1997b) suggested that the effect of delay on a critical gap is not significant. This may be due to the fact that there are minimal cases when drivers have to stop at the end of the auxiliary lane (EOAL) before merging. Kita (1993) suggested that the size of accepted gaps for merging traffic mainly depends on the relative speed between merge and motorway vehicles and also depends on the remaining distance for the EOAL with a tendency of drivers to accept smaller gaps when reaching the EOAL.

Table 2-1 Critical gap for merge traffic (Source: Worrall *et al.*, 1967)

Relative speed (Rv) (mph)	Mean (sec)	Standard deviation (sec)
$Rv < -5$	2.31	1.0
$-5 \leq Rv < +5$	2.46	1.0
$+5 \leq Rv < +15$	3.0	1.0
$Rv \geq 15$	3.8	1.0

b. Simulation and theoretical gap acceptance models

In simulation models, gap acceptance models are usually selected in order not to provide unrealistic behaviour when integrated with other parts of the simulation model such as CF and LC rules. For example, Gipps (1986) developed a safety gap acceptance model to be used with the Gipps (1981) safety car following model. In the DRACULA model (Liu *et al.*, 1995), the following safety gap acceptance equation was applied and integrated with the Gipps (1981) car following model. The gap obtained from the model was reduced for the case MLC.

$$g_{\min} = V_C \text{DRTc} + \frac{v_C^2}{2md_C} - \frac{v_{J1}^2}{2md_{J1}} + S_{\min} \quad \text{Equation 2-13}$$

where,

$g_{\min}$  is the minimum gap (m),

$md_C$  is the maximum deceleration rate of C ( $\text{m/sec}^2$ ).

$md_{J1}$  is the maximum deceleration rate of the new leader J1 ( $\text{m/sec}^2$ ), and

$V_C$  and  $V_{J1}$  are the speeds of C and J1 (m/sec).

The AIMSUN micro-simulation model which used the safety CF model put forward by Gipps (1981), suggested that the lead and lag gaps will only be accepted if they do not cause the lane changer and the new follower to decelerate with a rate sharper than  $-2\text{m/sec}^2$  (Barcelo and Casas, 2002).

Zia (1992), in his merging model, used 1 second as a critical value for lead gaps for all drivers and used a step function based on the work by Worrall *et al.* (1967) as presented in Table 2-1.

Hidas (2005) developed a simulation model for merge traffic and used Equation 2-14 which considers the effect of speed difference in the calculation of lead and lag gaps. Hidas ignored variability amongst drivers by using such functions. Also the gaps produced according to this formula are not safe since Hidas (2005) suggested a value of 0.9 for the constant part (i.e.  $c$ ) in the calculation of lead and lag gaps.

$$g_{min} = \begin{cases} c(V_C - V_{J1}) & \text{for lead gap} \\ c(V_{J2} - V_C) & \text{for lag gap} \end{cases} \quad \text{Equation 2-14}$$

where  $V_{J1}$  and  $V_{J2}$  are the speeds of the new leader  $J1$  and the new follower  $J2$  (m/sec).

Choudhury (2007) suggested that the accepted gaps are lower in situations of cooperative and forced merging. The trajectory data that were used in the development of the gap acceptance model revealed that there was a slight reduction in the size of the accepted lag gaps with the decrease in the distance to the EOAL.

Guan *et al.* (2010) ignored the variability amongst drivers by assuming that all drivers are homogeneous and will make the same choice for merging under the same conditions. They also assumed that the minimum (critical) gap ( $g_{min}$ ) for drivers decreased linearly with the increase of the driving distance in the auxiliary lane using the following theoretical model:

$$g_{min}(l) = \frac{h_{min} - g_{min}}{L_A} l + g_{min} \quad \text{Equation 2-15}$$

where,

$L_A$  is the length of the auxiliary lane (m),

$l$  is the travelling distance from the start of auxiliary lane (m),

$g_{min}$  is the minimum gap (sec),

$g_{min}(l)$  is the minimum gap at a distance  $l$  from the start of auxiliary lane, and

$h_{min}$  is the average minimum headway of motorway traffic (sec).

## 2.4. Summary

This chapter defined the macroscopic, mesoscopic and microscopic models and then concentrated on reviewing the existing research for the rules applied to microscopic models. The limitations in the existing merging models have been described and have highlighted the need for developing a new model that needs to take into consideration such issues, to make use of existing rules and algorithms and to apply the necessary modifications as required.

## CHAPTER THREE : TRAFFIC CONGESTION AND MANAGEMENT CONTROLS

### 3.1. Introduction

Avoiding traffic congestion is the main concern of traffic engineers since traffic congestion affects people by increasing the journey time and also adversely affecting the environment by increasing fuel consumption (Choudhury, 2007). However, most motorways are still operating under their capacities due to the propagating of traffic congestion for relatively long distances from bottleneck locations (Smaragdis *et al.*, 2004).

This chapter focuses on identifying the causes of traffic congestion and on suggested solutions particularly those solutions conducted by applying ramp metering (RM) controls.

### 3.2. Causes of traffic congestion

Traffic congestion is classified into either recurrent or non-recurrent (Papageorgiou and Kotsialos, 2002). Recurrent congestion involves the usual daily cases where congestion starts due to increasing flow rates within insufficient motorway bottleneck sections. The non-recurrent congestion involves other cases where congestion starts due to other reasons such as bad weather conditions, special events and roadworks. According to the Federal Highway Administration of America (FHWA, 2004), and as shown in Figure 3-1, 40% of traffic congestion cases involve recurrent congestion while 60% are related to non-recurrent congestions. The validity of these percentages for UK highways could not be confirmed since no similar data are available.

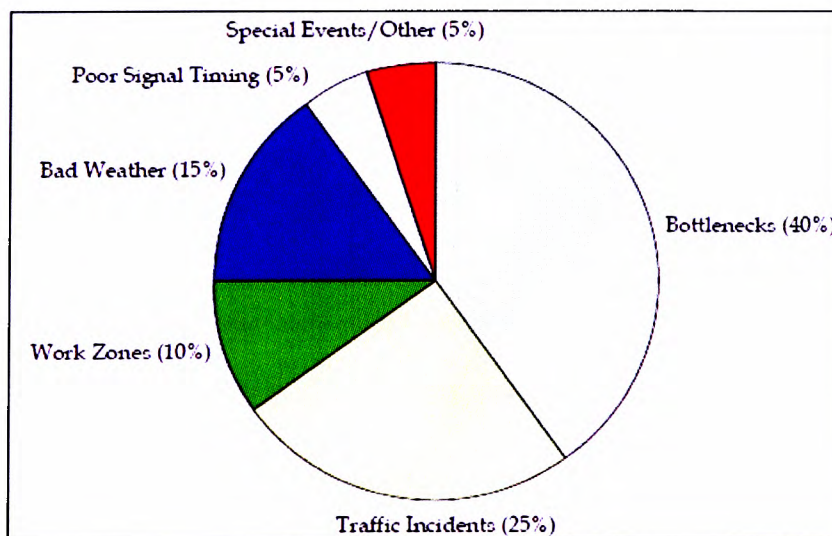

Figure 3-1 Causes of traffic congestion (Source: FHWA, 2004)



### 3.3. Effect of congestion on motorway capacity

Capacity is the maximum flow rate that could use a motorway section prior to the occurrence of traffic breakdown (Hounsell and McDonald, 1992). When traffic demands become higher than the capacity value, traffic congestion will be created. The maximum flow rates that the section could serve after the creation of traffic congestion is called “operational capacity” (Wu *et al.*, 2010).

Hounsell and McDonald (1992), based on data collected from UK motorway sites, found that the capacity value after the onset of congestion (i.e. operational capacity) was lower than the capacity value by about 7%. Papageorgiou and Kotsialos (2002) suggested that the operational capacity is lower than the capacity value by about 5-10%. Similarly, Zhang and Levinson (2010) found that the onset of traffic congestion causes 3-12% reduction in motorway capacity.

Wu *et al.* (2010) agreed with other studies about the stochastic nature of the capacity and concluded that the operational capacity is also varied based on the severity of traffic congestion. The severity of congestion is represented by the occupancy values as shown in Figure 3-2. The occupancy is defined as the percentage of time a traffic loop detector embedded in the road pavement is occupied by vehicles (Hall *et al.*, 1986). Increasing the occupancy value within the congested regions (as shown in the figure) means further decreasing in the operational capacity.

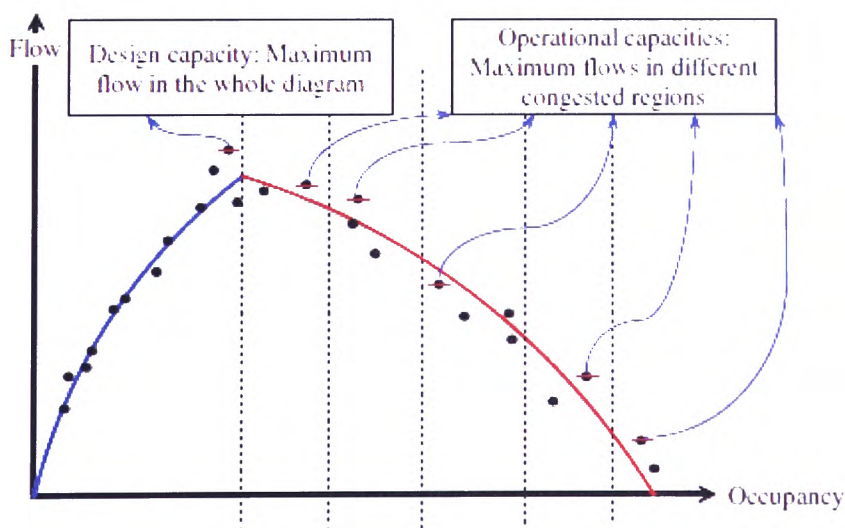

Figure 3-2 Operational capacity (Source: Wu *et al.*, 2010)

### 3.4. Traffic congestion solutions

The FHWA (2004) suggested possible solutions to traffic congestion as follows:

- Extension of the networks' infrastructure by adding lanes to the existing roads or building new ones. This solution is limited by many factors such as funding resources, land use, environmental constraints and others. Therefore, this seems not to be applicable for most metropolitan areas especially for those in developed countries.
- Manage the demand by using a variety of options to make more people travel using fewer vehicles and making trips during less congested periods. Example of such solutions is by encouraging public transport, road-pricing for travelling at peak periods and making the working hours more flexible.
- Operating the existing facilities more efficiently by applying Intelligent Transportation System (ITS) tools on the existing roads. Examples within this group are by using speed limits, RM and giving real time information to travellers. Currently, this group of solutions is widely used by local highway agencies with a popular use for the RM and speed limit controls.

This research focuses on RM applications and therefore RM will be explained in more details in the next sections of this chapter. Some studies related to the use of speed limit controls have also been described.

### 3.5. Speed limit controls

Speed limits are applied on motorway sections in order to reduce accident rates through reducing the variation in speed amongst drivers and are also used to enhance traffic conditions such as speed and capacity (Lu *et al.*, 2010). On UK motorways, the 70 mph (equivalent to 110 km/hr) is the national speed limit under normal traffic conditions. According to Heydecker and Addison (2011), and based on data from the M25 motorway, 40, 50 and 60 mph speed limit values are also applied in some instances at peak periods. The value of 40 mph is reported to be more frequently applied than the 50 and 60 mph values and is used in order to reduce flow rates joining downstream bottleneck sections.

In terms of the optimum speed limit, Heydecker and Addison (2011) reported that the optimum speed limit for the M25 motorway with 4 lanes is 50 to 60 mph depending on the



lane. The findings presented by Heydecker and Addison (2011) suggested that 50 mph is the optimum for lanes 1 and 2 while 60 mph is the limit for lanes 3 and 4.

According to Hegyi *et al.* (2005), field tests in the Netherlands showed that the applying of a 50 mph speed limit could enhance traffic safety without improving traffic speed and capacity. Similarly, Nissan and Koutsopoulos (2011) examined the effect of the advisory speed limit applied on the E4 motorway in Stockholm and reported that the speed limit did not have any significant effect on traffic conditions. Geistefeldt (2011) evaluated the effect of permanent and variable speed limits on capacity based on data from Germany. The results showed that the variance in the observed capacity was significantly reduced while the average capacity is slightly increased.

Papageorgiou *et al.* (2008) concluded that the applying of speed limits on sections that carry flow rates lower than the capacity (referred to as “under-critical sections”) will increase the travel time and reduce the capacity. They also concluded that there is no clear evidence that the speed limit could improve traffic conditions.

### **3.6. Ramp metering (RM) controls**

#### **3.6.1. Evolution of RM**

RM is one type of traffic management control which involves installing traffic signals on slip roads (on ramps) to control the rate of vehicles entering the motorway sections. The idea is to avoid/alleviate congestion by preventing the sum of the motorway upstream flows and merge flows from being higher than the capacity of the downstream section. This is conducted by storing some of the merge traffic on slip roads through setting the signals to different metering rates (veh/hr) during peak periods. Another objective of applying RM control is to enhance traffic safety through making the merging smoother.

This type of traffic control started in the 1960s with the basic idea when a police officer managed the entering traffic into a freeway system in the USA in a manual way (Levinson *et al.*, 2004). The idea was then transferred to fixed time signal controls in Chicago in 1963. Currently, RM operates smart signals which release traffic from slip roads based on specific algorithms.

The success of RM applications in the USA led to the deployment of RM to be installed in several countries in Europe including the United Kingdom, Germany, France, Belgium and the Netherlands. According to the UK Highways Agency (<http://www.highways.gov.uk/>).

the first application for RM in UK was on the M6 J10 near Birmingham in 1986. As a result of this successful implementation, RM systems were subsequently installed during 1988 on many other junctions on the same motorway. The system remained in operation until May 2000 when the equipment became obsolete and was consequently switched off. The Ramp Metering Pilot Scheme (RMPS) developed a new control system for the M3/M27 pilot project (Gould *et al.*, 2002). The original RM equipment on the M6 was replaced by similar systems to that developed by the RMPS. Due to the success in implementing RM (according to the Highways Agency), in 2010 there were 88 RM sites deployed across the UK.

### 3.6.2. RM components

In addition to traffic signal devices, the main components required to operate RM controls include installing traffic loop detectors and advance warning signs. A typical example for the RM system that is applied at UK sites is shown in Figure 3-3. For the main motorway, upstream and downstream detectors are required to decide whether or not RM needs to be operated and also in updating the traffic signal timings based on certain traffic variables such as speed, flow and occupancy. For the slip roads, the following types of loop detectors are required (Highways Agency, 2008):

- Release loop detectors installed at a distance of 2m downstream of the stop line to estimate the flow rates that have left the stop line.
- Presence loop detectors installed at a distance of up to 50m upstream of the stop line to indicate the presence of stopped vehicles at the stop line.
- Queue override loop detectors (QOD) installed at a distance of 39 meters from the start of the slip road to indicate queues reaching the end of the storage area (i.e. the slip road).
- Queue detection loop detectors installed between the presence loops and the queue override loops at each 25m interval. These loop detectors are used in estimating the queue lengths that are created upstream of the stop line.

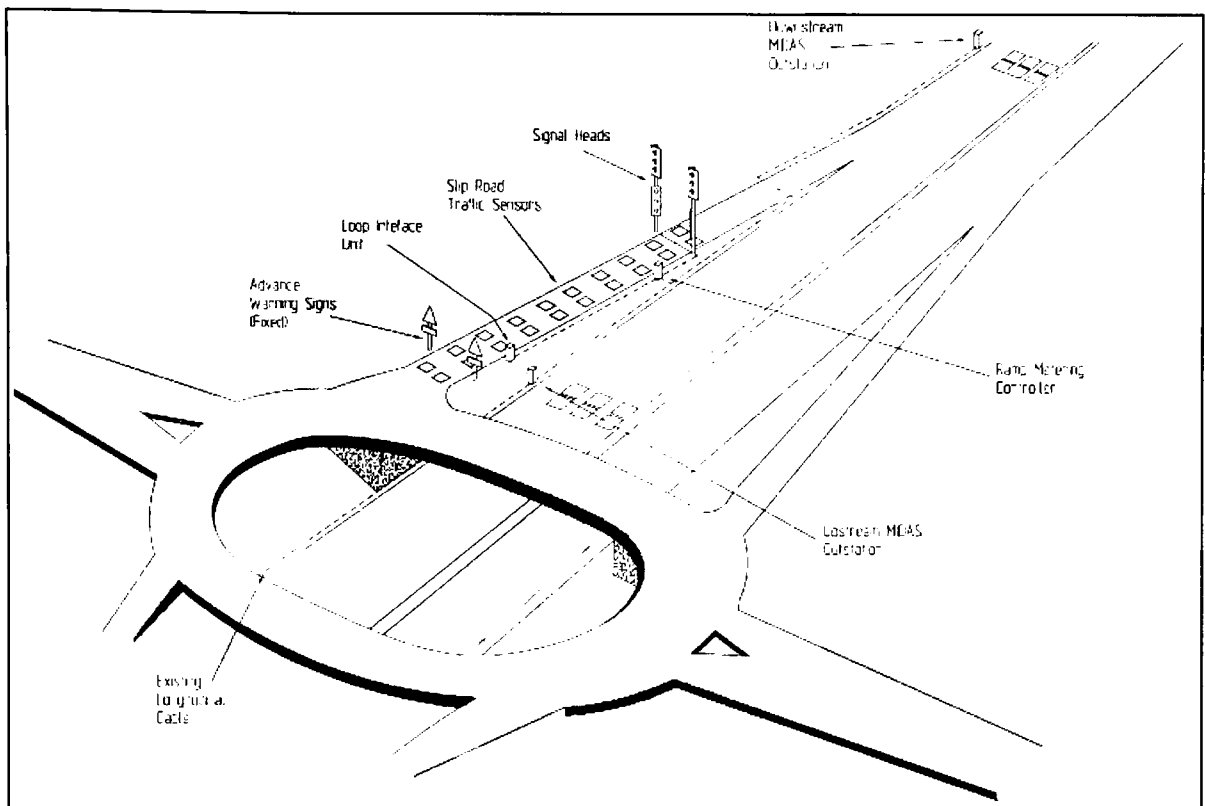

Figure 3-3 Example of RM system (Source: Highways Agency, 2007)

### 3.6.3. RM algorithms

On the basis of operational level, RM can be classified into local and area wide. Local RM calculates the metering rate for an isolated on-ramp to control the traffic characteristics of a motorway section. There are two types of area-wide RM namely, coordinated and integrated. Coordinated RM uses traffic measurements from different locations to calculate the metering rate for a series of traffic signals on successive ramp sections. Integrated RM does not only include information from motorways, but also information from the arterial system in order to provide metering rate calculations (Sarintorn, 2007). Because the local RM system is widely applied in the UK, this research will focus on this type only. Based on how the individual algorithm is sensitive to real time traffic, local RM strategies are divided into fixed time and reactive strategies. The cycle timings in the fixed time RM signals (which represents the earlier version of RM controls) are derived from historical demand data without considering any live measurements (Papageorgiou and Kotsialos, 2002). Various types of reactive local RM strategies have been developed. Below is the description of the main types of these reactive algorithms.

### 3.6.3.1. Demand-Capacity (D-C) algorithm

This algorithm (see Equation 3-1) was derived based on the principle that the metering rate should not exceed the difference between the capacity of the motorway downstream section and the motorway upstream flow rates. In cases where traffic congestion is identified, where the downstream occupancy exceeds a critical value ( $O_{cr}$ ), only the minimum metering rate ( $qr_{min}$ ) will be released from the RM signals (Masher *et al.*, 1975). The critical occupancy ( $O_{cr}$ ) is the occupancy value which corresponds to motorway capacity (Hall *et al.*, 1986).

$$qr(k) = \begin{cases} q_{cap} - q_{in} & \text{if } O_{out} < O_{cr} \\ qr_{min} & \text{else} \end{cases} \quad \text{Equation 3-1}$$

where,

- $O_{out}$  is the measured downstream occupancy in (%),
- $O_{cr}$  is the critical occupancy in (%),
- $q_{cap}$  is the motorway capacity in (veh/hr),
- $q_{in}$  is the upstream flow in (veh/hr), and
- $qr(k)$  is the metering rate for current time interval (k) in (veh/hr).

When the loop detectors are only available on the upstream section of the main motorway, the occupancy  $O_{out}$  is replaced by the occupancy taken from the upstream detectors in identifying whether congestion is occurring.

Applying the D-C algorithm requires knowledge of the motorway capacity from historical data. This capacity is subject to change due to many factors such as environmental conditions (Papamichail and Papageorgiou, 2008) as well as the percentage of heavy goods vehicles within the traffic (Hounsell and McDonald, 1992).

### 3.6.3.2. Demand Capacity INRETS

This algorithm requires three mainstream detectors stations to estimate the degree of congestion and to state the required metering rate. The strategy works exactly as in the D-C algorithm for free-following conditions and under severe congestion conditions. For slight and stronger congestion (Haj-Salem *et al.*, 1990) the metering rate is calculated using the following formula:

$$r(k) = B q_{out} - q_{in} \quad \text{Equation 3-2}$$

where,

- B is a constant equal to 1.0 for slight congestion and 0.9 for stronger congestion, and
- $q_{out}$  is the downstream capacity.

### 3.6.3.3. RWS algorithm

This algorithm has been applied in the Netherlands since 1989 and operates in a similar way to the D-C algorithm (Taale and Middelham, 2000). The only difference is that the RWS algorithm uses the upstream speed calculation to indicate the onset of congestion rather than using the downstream occupancy.

### 3.6.3.4. Percent occupancy algorithm

The calculation of the metering rate in this algorithm is identical to that obtained from the demand capacity (D-C) algorithm as in Equation 3-1. However, the upstream flow ( $q_{in}$ ) is estimated from a linear approximation for the flow-occupancy relationship (Smaragdis and Papageorgiou, 2003).

### 3.6.3.5. ALINEA algorithm

According to Smaragdis *et al.* (2004), using a critical occupancy which corresponds to the maximum flow gives more stable results than relying on the capacity value. Based on this approach, the ALINEA algorithm, which stands for Asservissement LINéaire d'Entrée Autoroutière (Papageorgiou *et al.*, 1991), tries to keep occupancy levels downstream of the merging area close to the critical occupancy. This requires only one detector stationed downstream of the merge area to measure occupancy ( $O_{out}$ ). The algorithm uses the system output  $qr(k-1)$  from the previous cycle (which normally ranges between 10 and 40 seconds) as an input into the calculation of the current metering rate  $qr(k)$ , as in Equation 3-3.

$$qr(k) = qr(k - 1) + K_R(O_{des} - O_{out}(k - 1))100 \quad \text{Equation 3-3}$$

where,

- $K_R$  is the regulator parameter which was found to be 70 veh/hr based on work undertaken by Haj-Salem *et al.* (1990), and
- $O_{des}$  is the desired occupancy (%) which may equal, but not necessarily, to the critical occupancy ( $O_{cr}$ ).

### 3.6.3.6. ALINEA extended algorithms

Although ALINEA has been used in different countries, there has been a lot of research to enhance this algorithm to address some of its limitations. Here is a summary of these studies.

a. MALINEA algorithm (Oh and Sisiopiku, 2001)

The Modified ALINEA (MALINEA) algorithm was designed to address two possible difficulties in applying ALINEA. The first is that ALINEA could not prevent congestion in the upstream merge section. The second is related to the difficulties associated with selecting the optimum position for the downstream detectors' station. MALINEA uses the upstream occupancy ( $O_{in}$ ) rather than the downstream one ( $O_{out}$ ). The formula for this algorithm is:

$$qr(k) = qr(k - 1) + \frac{K_R}{A} (O_{in}(k) - O_{in}(k - 1)) \quad \text{Equation 3-4}$$

where A is the slope of the curve relating to the downstream and upstream occupancies.

b. FL-ALINEA (Smaragdis and Papageorgiou, 2003)

The Flow ALINEA (FL-ALINEA) algorithm requires the flow measurement ( $q_{out}$ ) taken from downstream detectors as well as the occupancy measurement, as in Equation 3-5. The regulator parameter ( $K_R$ ) for this algorithm is reported to be around 1.0.

$$qr(k) = \begin{cases} qr(k - 1) + K_R(q_{cap} - q_{out}(k - 1)) & \text{if } O_{out} < O_{cr} \\ qr_{min} & \text{else} \end{cases} \quad \text{Equation 3-5}$$

c. UP-ALINEA (Smaragdis and Papageorgiou, 2003)

The upstream ALINEA (UP-ALINEA) algorithm was designed to be relevant for main motorway sections that only have upstream detectors. The algorithm uses the measured upstream occupancy in estimating the downstream occupancy, as in Equation 3-6.

$$O_{out}(k) = O_{in}(k) \left[ 1 + \frac{q_{ramp}(k)}{q_{in}(k)} \right] \frac{\lambda_{in}}{\lambda_{out}} \quad \text{Equation 3-6}$$

where,

$\lambda_{in}$  and  $\lambda_{out}$  are number of lanes in the upstream and downstream merge area, respectively, and  
 $q_{ramp}(k)$  is the flow (veh/hr) of the merge section during interval k.

The algorithm then applies the same equation as the original ALINEA (i.e. Equation 3-3) to calculate the metering rate. Equation 3-6 is derived based on the assumption that average downstream speed is equal to that in the upstream section.

d. UF-ALINEA (Smaragdis and Papageorgiou, 2003)

This algorithm is also relevant for main motorway sections that do not have downstream loop detectors. The Upstream Flow ALINEA (UF-ALINEA) estimates the downstream

flow as the sum of the motorway upstream and the ramp flow while the downstream occupancy is estimated from Equation 3-6. Then the algorithm applies the same equation as in the FL-ALINEA algorithm.

e. AD-ALINEA (Smaragdis et al., 2004).

The Adaptive ALINEA (AD-ALINEA) algorithm was designed to use real time critical occupancy rather than relying on a fixed value. This is to deal with situations where the critical occupancy becomes changeable due to, for example, weather conditions and in situations where the congestion starts further downstream and propagates to reach the merge section. The procedure adopted in estimating the real time critical occupancy (see Figure 3-4) is by adding ( $\Delta\%$ ) to the critical occupancy value based on the rate of change of flow to occupancy values (i.e. ROC) using Equations 3-7 and 3-8. This algorithm then applies Equation 3-3 for estimating the metering rate by assuming that  $O_{des}$  is equal to  $O_{cr}$ .

$$ROC = \frac{q_{out}(k) - q_{out}(k-1)}{O_{out}(k) - O_{out}(k-1)} \quad \text{Equation 3-7}$$

$$O_{cr}(k) = O_{cr}(k-1) + \begin{cases} -\Delta & \text{if } ROC < 0 \\ +\Delta & \text{if } ROC > 0 \\ 0 & \text{Else} \end{cases} \quad \text{Equation 3-8}$$

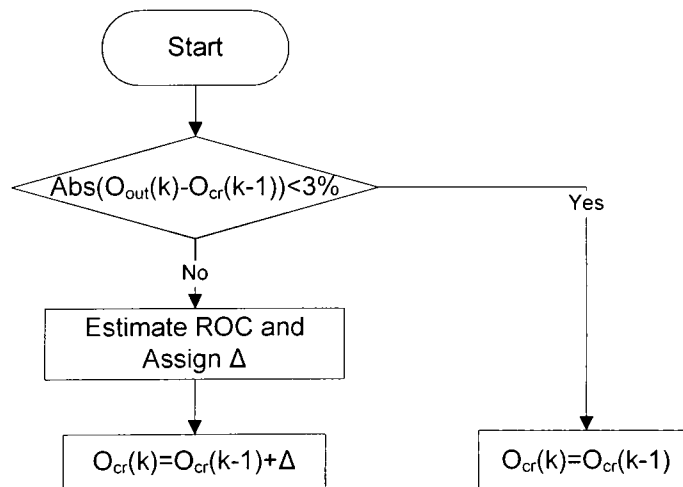

Figure 3-4 Procedure of estimating the critical occupancy in AD-ALINEA algorithm

f. AU-ALINEA (Smaragdis et al., 2004).

The Adaptive Upstream ALINEA algorithm (AU-ALINEA) was proposed to modify AD-ALINEA to be based on the upstream measurements of occupancy by applying a similar procedure to that used in UP-ALINEA.

g. PI-ALINEA (Wang and Papageorgiou, 2006)

The Proportional-Integral algorithm (PI-ALINEA) considered cases that have a distant downstream bottleneck (i.e. when congestion starts further downstream of the merge section). The algorithm uses the occupancy measurement ( $O(k)$ ) from the further downstream location to calculate the metering rate using the following equation:

$$qr(k) = qr(k - 1) + K_P[O_{out}(k) - O_{out}(k - 1)] + K_R[O_{cr} - O_{out}(k)] \quad \text{Equation 3-9}$$

where  $K_P$  is the additional regulator parameter ( $K_P > 0$ )

Wang *et al.* (2010) extended the PI-ALINEA to be based on different locations for the loop detectors downstream rather than relying on just one location in order to consider situations when downstream bottlenecks occurred in random locations.

### 3.6.3.7. Speed-Occupancy algorithm

From studying traffic characteristics on the Beijing urban expressway in China, Xuewen *et al.* (2007) found that both speed and occupancy parameters could reflect traffic conditions. Therefore, they developed a RM algorithm using both speed and occupancy.

Two metering rates are calculated. The first ( $qr_1(k)$ ) is exactly as in ALINEA using the upstream occupancy measurement. The second ( $qr_2(k)$ ) is based on upstream speed measurements using Equation 3-10. The applied metering rate during the next signal timings is the smoothed metering rate between  $qr_1(k)$  and  $qr_2(k)$ .

$$qr_2(k) = qr_2(k - 1) + K_{R2} \left( \frac{V_u(k-1)}{V_{cr}} - 1 \right) \quad \text{Equation 3-10}$$

where,

$K_{R2}$  is the regulator parameter based on speed calculations,

$V_{cr}$  is the critical speed, and

$V_u$  is the upstream speed (km/hr).

### 3.6.3.8. ANCONA algorithm

Kerner (2007a, b, c and d) opened a wide discussion on the effectiveness of the ALINEA algorithms. Kerner (2007b) suggested that relying on the downstream detectors to trigger the RM signals is not efficient because such locations will be downstream of the active bottleneck location and therefore it could not be sensitive to the occurrence of traffic congestion. Kerner (2007c) developed a congested pattern algorithm "ANCONA" which triggers RM just in the cases where traffic congestion propagates upstream of the active bottleneck location. ANCONA uses one detectors' station to measure the average speed



upstream of the merge area. The algorithm only works when speed is reduced below that of the “congested indicator,  $S_{p1}$ ” of 60-80 km/hr. In such situations, the metering rate is assumed to be ( $q_1$ ) which is less than the ramp flow. When the speed is increased above that of the “congestion indicator”, the metering rate is assumed to be ( $q_2$ , where  $q_2 > q_1$ ). The ramp traffic signals will be turned off (shut down) only when the upstream speed is higher than the “congestion indicator” for a relatively long period ( $P$ ).

### 3.6.3.9. Ramp metering pilot scheme algorithm (RMPS)

This strategy has been implemented by the UK Highways Agency using various rules to control traffic signal timings. These include switch on/off algorithms to trigger on or off the RM based on motorway traffic conditions. The metering rate is fairly obtained based on ALINEA (Highways Agency, 2007). In addition, there are additional rules to ensure that the metering rate does not enable the created queues on the ramp section to be extended further back into other network(s) (i.e. queue override strategy as will be explained later). Examples of the metering rates and the signal timings for the RMPS algorithm are shown in the Table 3-1, which is currently applied to the M60 J2 RM site. The M60 is the outer ring road of Manchester. The signal timings in the UK system include the “red-amber” period to alert drivers about the forthcoming green period (EURAMP, 2007). As shown in the table, the red periods decrease with increases in the metering rate while other timings are fixed.

Table 3-1 Signal timings for the M60 J2 RM site, UK

Release Stage	Metering rate (veh/hr)	Timing (sec)			
		Green time	Stop amber	Red time	Red-amber
1	500	2	3	25	2
2	650	2	3	17	2
3	800	2	3	12.5	2
4	950	2	3	9.5	2
5	1100	2	3	7.25	2
6	1250	2	3	5.5	2
7	1400	2	3	4.25	2
8	1550	5	3	5	2
9	1700	5	3	3.75	2
10	1850	5	3	3	2
11	2000	RM turn off (shutdown)			
12	2600				

### 3.6.3.10. Other RM algorithms

Currently, the Demand-Capacity (D-C) and the ALINEA local RM algorithms are widely used across many countries. However, local highways' agencies usually modify these

methods based on their local traffic conditions. For example, the RMPS algorithm which applies in the UK is originally based on the ALINEA algorithm with some changes. In the USA where the D-C algorithm is more popular, some slight modifications were made to the method such as those modifications made by the Semi Actuated Metering System (SATMS) algorithm which uses different minimum metering rates in congested situations rather than using a fixed minimum rate (Chu *et al.*, 2009).

### 3.6.4. Summary of the RM algorithms

Section 3.6.3 gives details on some of the local reactive RM algorithms. The summary for the parameters required for each algorithm is presented in Table 3-2. Some of these algorithms (e.g. UP-ALINEA and ANCONA) require measurements from upstream detectors while others (e.g. ALINEA and RMPS) require measurements from the downstream ones. The operational procedure for these algorithms is also different whereby most use occupancy measurements (e.g. ALINEA and D-C), while some use speed measurements (e.g. RWS and ANCONA). In determining the approach used for these algorithms, some rely on feed-forward information from loop detectors (i.e. stimulus corresponds to anticipation of future demand), others on feedback (i.e. stimulus corresponds to measure performance) or even a combination of the two.

Table 3-2 The required measurements for each RM algorithm

Algorithm	Motorway						Ramp
	Flow		Occupancy		Speed		Flow
	Down <sup>1</sup>	Up <sup>2</sup>	Down	Up	Down	Up	
D-C		√	√				
D-C INRETS		√	√				
RWS		√				√	
Percent occupancy		√		√			
ALINEA			√				
MALINEA			√	√			
FL-ALINEA	√		√				
UP-ALINEA		√		√			√
UF-ALINEA		√		√			√
AD-ALINEA	√		√				
AU-ALINEA		√		√			
PI-ALINEA			√				
Speed-Occupancy				√		√	
ANCONA						√	
RMPS	√		√				

(1) Downstream, (2) Upstream

As previously discussed in section 3.6.3, the ALINEA and its derivatives algorithms are based on the feedback control theory where these algorithms estimate the metering rate by comparing the current occupancy with that desired and use the system output (i.e. metering rate) from the previous cycle length in calculating of the new metering rate. The other algorithms such as D-C, RWS and ANCONA algorithms are not based on feedback calculations where the calculation of the metering rate is not affected by that rate obtained from the previous cycle. Some of the above algorithms (and their assumptions) have been selected for testing the effectiveness of RM controls as shown in Chapter 8.

### 3.6.5. Queue override strategies (QOSs)

The negative effect caused by RM controls is the formation of queues on ramp sections upstream of the traffic signals. If the operation of RM is not properly considered such queues, and the spilling back of such queues, may affect the adjacent network(s). Therefore, different QOSs are applied taking the effect of ramp queue length into the calculation of the metering rates.

Hadj-Salem *et al.* (1990) reported that queue override strategy (QOS) is applied at different sites in Paris by using a fixed time cycle length with higher values for green periods. This is applied once the queue on slip roads occupies the whole storage (ramp) length. Similarly, Zheng (2003) stated that the procedure adopted for the QOS at M27 J10 (near Southampton, UK) is by triggering a 20 second green time signal (based on a cycle time of 30 seconds) when the queues on the ramp section reach the queue override detectors (QOD-as described above in section 3.6.2). Such queues are identified when the occupancy value at the QOD exceeds a specific threshold (about 50% according to Smaragdis and Papageorgiou (2003) and others). If after these 20 seconds of green time, the estimated occupancy is lower than the selected value, the calculation of the next metering rate will revert back to the normal RM rates' calculations.

Gordon (1996) reported that most QOSs assign one or two occupancy threshold values to the QOD. Once the first limit is exceeded, the metering rate will be increased. If the second threshold is also exceeded, the signals will be turned off. The latter process will allow for platoons of vehicles to merge together and this will reduce motorway speed and capacity. This also causes significant oscillation in the queue length (i.e. without sufficient use for the available storage length). The developed QOS by Gordon (1996), as shown in Figure 3-5, suggested increasing the metering rate to between 700 and 900 veh/hr in the case where the "control variable (CONV)" is higher than a limit of 30-40%, while the

normal metering rate taken from the RM algorithm is applied in other cases. The “control variable” is estimated (see Equation 3-11) based on the filtered occupancy as well as the rate of change in the filtered occupancy value compared with the previous time interval. The filtered occupancy is estimated as the average occupancy values at the current and the previous time intervals.

$$\text{CONV} = O_f(k) + K1\left(\frac{O_f(k) - O_f(k-1)}{T}\right) \quad \text{Equation 3-11}$$

where,

$K1$  is a constant (about 10 based on Gordon (1996)),

$O_f(k)$  and  $O_f(k-1)$  are the filtered occupancy values at the current and previous time intervals, respectively, and

$T$  is the time period over which measurements are taken (sec).

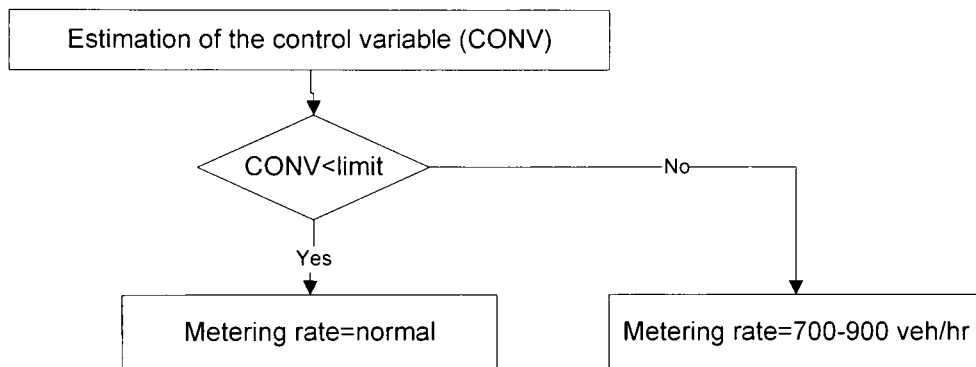

Figure 3-5 Flowchart of Gordon's (1996) QOS

Smaragdis and Papageorgiou (2003) proposed the X-ALINEA/Q algorithm to deal with ramp queues when the ALINEA (or any of its derivatives) algorithms are applied. Two metering rates are calculated. The first ( $r(k)$ ) is derived from the applied RM algorithm such as those described above and the second ( $r'(k)$ ) is the minimum rate to keep the ramp queue length below the maximum allowable queue length ( $w_{\max}$ ) using Equation 3-12.

$$r'(k) = \frac{-1}{T} [w_{\max} - w(k)] + d(k-1) \quad \text{Equation 3-12}$$

The selected metering rate in the current time interval is the maximum of these two metering rates. The number of vehicles in the ramp queue is calculated using Equation 3-13.

$$w(k) = w(k-1) + T[d(k-1) - r'(k-1)] \quad \text{Equation 3-13}$$

where,

$d(k-1)$  is the demand flow entering the ramp in the previous time interval.

$r'(k)$  is the minimum rate to prevent queue build up.

$r'(k-1)$  is the minimum rate to prevent queue build up in the previous time interval.

$T$  is the time period over which measurements are taken (hr).

$w(k)$  is the number of vehicles in ramp queue (veh),  
 $w(k-1)$  is the number of vehicles in ramp queue in the previous time interval, and  
 $w_{\max}$  is the maximum allowable queue length (veh).

Chu *et al.* (2009) reported that the Semi Actuated Metering System (SATMS) algorithm uses a cycle length with enough green time to release 900 veh/hr/lane. This is applied once the queue reaches the QOD.

### 3.6.6. Evaluation studies for RM

Many studies have investigated the effectiveness of RM controls utilised all over the world using either real traffic data or using simulation models. The main factors that were considered covered total time spent for motorway traffic (TTSM), total time spent (TTS) (i.e. the overall time spent for motorway and ramp traffic), capacity (throughput), speed and safety. Below is a description of some of these studies.

#### 3.6.6.1. Empirical studies

Owens and Schofield (1990) evaluated the effectiveness of RM at the M6 J10, UK. According to their study, the morning peak downstream flow was increased by 3.2% and the journey time was reduced by 2-13%.

Hadj-Salem *et al.* (1990) tested several RM strategies including ALINEA and D-C algorithms on the southern part of the Boulevard (Paris). The study showed that ALINEA could increase the throughput by 3% and decrease the total travel time by 19%. The QOS were used by triggering only green time if the queues on the ramps reached the ramp queue detectors.

Endo and Janoyan (1991) found that time-responses RM could reduce the overall delay by about 5% compared with fixed time RM.

Hadj-Salem and Papageorgiou (1995) evaluated the ALINEA algorithm using data from a series of ramps in Paris. The results of testing three RM sites suggested some variation in the effectiveness of RM as there were 8.1% and 6.9% saving in total travel time for two of the sites while there was an increase of about 20% for the third RM site. The average reduction in travel time was 5.9% for the whole network.

Taale and Middelham (2000) summarised the work which had been conducted in the Netherlands regarding the performance of RM controls for a period between 1990 and 2000. The positive effect of RM on capacity varied from 0 to 5%. Speeds on the motorways were increased by 5-30 km/hr and the motorway travel time was reduced by

3-10%. The applied RM algorithms were ALINEA, D-C and an algorithm based on fuzzy logic.

The Minnesota Department of Transportation (MnDOT, 2001) conducted an evaluation study on RM in the Twin Cities metropolitan area in the USA. The results showed that RM was capable of increasing the flow by 9% and decreasing the travel time for motorway traffic by 22%. The negative effect of RM on merge traffic delay was pronounced when such delays reached about 2.3 minute/vehicle while there was no considerable delay for merge traffic in the case of being “without” RM. With regard to safety, it was found that RM reduced crashes during peak periods by 26%. The overall annual benefit and cost study showed that the benefit/cost ratio was 5:1.

Cassidy and Rudjanakanoknad (2005) evaluated the performance of the D-C algorithm in the USA and suggested that RM could increase the capacity by about 10%. The maximum metering rate of 700 veh/hr was applied with occupancy value below 22% or during the transition period when the occupancy rises from 22 to 27%. The minimum metering rate of 400 veh/hr was used for an occupancy value higher than 27% or during the transition period when the occupancy drops from 27 to 22%. No QOS was applied during their data collection.

The UK Highways Agency (2007) issued a summary report based on data taken from 30 RM sites. The report suggested that RM increased the overall peak period flows and speeds by 1-8% and 3.5-35%, respectively. The average saving in travel time of the mainline traffic was about 13% for all sites. The average delay for slip road vehicles varied from 15 to 78 seconds.

A detailed evaluation study of the impact of RM on drivers' behaviour was conducted by Wu *et al.* (2007) mainly using instrumented vehicle data from the M27 J11 in the UK. The RM control at this site was based on the RMPS algorithm which is fairly similar to the ALINEA algorithm (Highways Agency, 2007). The main findings of their study came out in contradiction to other work. Although RM was found to improve the merge condition, the study showed that the average motorway speeds were slightly reduced. Merging speeds (speeds of merging traffic) in the case of “with” RM were lower than those in the case of “without” RM. The study showed that the operation of RM may significantly increase the number of lane changes from lane 1 to lane 2 in the pre-merge zone.

Zhang and Levinson (2010), using data from the USA, reported that RM could increase the discharge flow by 3% and could also prevent the creation of a bottleneck in 14 out of the

27 studied sites. No information was given about the methods that were used to trigger the RM controls. However, and according to Chu *et al.*, (2009), most of the RM sites in the USA are working under logic similar to that in the D-C algorithm.

A summary of the above points and some other empirical studies are shown in Table 3-3.

Table 3-3 Summary of some of the empirical studies that have evaluated RM

Country	Algorithm	Reported effectiveness	Reference
UK	Fixed time	Capacity (+3.2%) TTSM (-2 to -13%)	Owens and Schofield (1990)
	RMPS	Capacity (+1 to +8%) Speed (+3.5 to +35%) TTSM (-13%) Ramp delay (78sec/veh)	Highways Agency (2007)
		Speed was slightly reduced	Wu <i>et al.</i> (2007)
France	ALINEA	Capacity (+3%) TTS (-19%)	Hadj-Salem <i>et al.</i> (1990)
		TTS (-5.9%)	Hadj-Salem and Papageorgiou (1995)
Netherlands	ALINEA and D-C	Capacity (0 to +5%) Speed (5 to +30%) TTSM (-3 to -10%)	Taale and Middelham (2000)
USA	D-C	Capacity (+9%) TTSM (-22%) Crashes (-26%) Ramp delay (2.3min/veh)	MnDOT (2001)
		Capacity (+10%)	Cassidy and Rudjanakanoknad (2005)
		Prevented congestion on 14 out of 27 RM sites	Zhang and Levinson (2010)

### 3.6.6.2. Simulation studies

Hasan *et al.* (2002) and Ben-Akiva *et al.* (2003) used MITSIMLab micro-simulator to test the effectiveness of ALINEA with and without the use of QOS. Their study showed that for the case of no queue control, ALINEA increased ramp delay by 133.4% and the overall time delay for motorway plus merge traffic was increased by 18.5%.

Smaragdis and Papageorgiou (2003) suggested that the ALINEA algorithm and its derivatives could successfully prevent congestion where there is no limit for the ramp queue length. However their simulation results showed that the created queue length on the ramp section reached about 500 vehicles (equivalent to 4-5 km long). The same study showed that if the QOS are applied, ALINEA is still capable of preventing traffic congestion until the ramp queue reaches the maximum allowable length of 300 vehicles

(equivalent to 2.5-3 km long). Indeed, such storage lengths are not available in real life as most existing ramps do not exceed 300m in length (Highways Agency, 2008).

Sisiopiku *et al.* (2005) used CORSIM model (FHWA, 2007) to investigate the performance of the ALINEA and D-C algorithms. Mainline flow rates were varied from 2000 to 5500 veh/hr and the ramp flows ranged from 200 to 1500 veh/hr. No limitations for the ramp queue length were applied (i.e. no QOS were used). The main finding was that the RM was able to prevent congestion from spillbacks upstream by keeping speeds higher than 60 mph (96 km/hr). Surprisingly, the results of their study suggested that RM will operate even under low traffic demand when the flow of a 3-lane motorway plus ramp flow is under 3000 veh/hr.

Bellemans *et al.* (2006) applied a macro-simulation model to test ALINEA in Belgium and concluded that the algorithm could reduce travel time by about 0.2-0.9%. The QOS were operated when the created queues on the ramp section reached a maximum length of 100 vehicles.

Horowitz *et al.* (2005) used a VISSIM micro-simulation model to study the performance of some of the RM algorithms. The storage length was assumed to be lower than 40 vehicles for most of the simulation runs. However, the QOS were only applied when the speed of the motorway was higher than 35 mph. Their results showed that the ALINEA has a negative impact on travel time. The study used 1 second for the “waiting time before diffusion” parameter (see section 2.3.3) to remove the stopped vehicles from the simulation system once these vehicles reached the end of the auxiliary lane. This assumption is not logical and therefore may affect their results.

Papamichail *et al.* (2010) used a METANET macro-simulation model and concluded that using a coordinated control approach to meter all junctions in Amsterdam’s ring-road (including freeway to freeway (ftf) junctions) could enhance traffic conditions for the whole network. This was subject to the availability of sufficient ramp storage spaces. The maximum storage lengths of (100 and  $\infty$ ) vehicles for “ftf” on-ramps and (30 and  $\infty$ ) vehicles for urban on-ramps were used in their study. The results from the ALINEA control showed that when there was no limit for the ramp queue length, the total travel time was reduced by 45%. The scenario of a (30,  $\infty$ ) vehicle queue length for urban and “ftf” ramps respectively, gave only a 2% reduction in travel time while the ramp queue length reached about 1200 vehicles (equivalent to about 10 km long) on the “ftf” ramps.

Wang *et al.* (2010) used the extended version of PI-ALINEA (see section 3.6.3) with



random bottleneck locations and suggested that the algorithms could prevent congestion on a motorway section for different locations of downstream bottlenecks. Their simulation results (using flow rates of 4400 and 1350 veh/hr for motorway and merge traffic, respectively) suggested that the ramp queues reached about 800 vehicles (equivalent to about 6-7 km long).

Studies by Kotsialos and Papageorgiou (2004), Kotsialos and Papageorgiou (2005), Smaragdis *et al.* (2004) and Papamichail *et al.* (2010) used a macroscopic approach and suggested that ALINEA is useful in reducing the travel time if there is to be no consideration of the maximum queue length on the ramp sections (i.e. no QOS were used).

A summary of the above and some other studies are shown in Table 3-4.

### 3.6.6.3. Limitations in the RM evaluation studies

The above section revealed some limitations in the existing studies which deal with RM. The main limitations can be summarised as follows:

- Some studies have applied micro-simulation models which have unrealistic assumptions in representing traffic in merge sections.
- Some studies have used a macroscopic approach and have ignored the interactions between individual vehicles.
- Most of the simulation studies that have supported the use of RM did not consider the effect of having limited storage lengths.
- The existing studies did not explain why RM is useful in some situations and not in others.
- The range of flow rates at which RM is useful need to be obtained through testing different ranges of motorway and merging flow rates.

Such limitations in the simulation approach are considered in this study by developing a new traffic micro-simulation model which could reasonably represent real traffic behaviour at a merge section and which is also able to include different RM algorithms to test their effectiveness and by suggesting some modifications to enhance the performance of RM.

## 3.7. Summary

This chapter discussed the effect of traffic congestion on the capacity of motorway sections and presented some of the traffic management control systems such as speed limits and ramp metering (RM). The chapter focused on describing the main local RM algorithms and

the evaluation studies for the RM systems. Some of the limitations in these studies were described. For the purpose of this study, ALINEA, D-C, ANCONA and RMPS were selected taking on board the described limitations in testing the effectiveness of these RM algorithms.

Table 3-4 Summary of some of the simulation studies that have evaluated RM

No.	Simulation model	Algorithm	Ramp storage length	Impact	Reference
1	Macro-simulation using METANET	ALINEA UP-ALINEA FL-ALINEA UF-ALINEA	∞	Prevent congestion	Smaragdis and Papageorgiou (2003)
2		X-ALINEA/Q	300 veh	No congestion before operating the QOS	
3		ALINEA	∞	TTS (-44%)	Kotsialos and Papageorgiou (2005)
4			100-200 veh	TTS (-26%)	
5		Coordinated RM	40-100 veh 80-120 ∞	TTS (-31.7%) TTS (-37.8%) TTS (-43.5%)	Kotsialos and Papageorgiou (2004)
6		ALINEA	∞	Prevent congestion	Smaragdis <i>et al.</i> (2004)
7	Micro-simulation using MITSIMLab	RMPS ALINEA X-ALINEA/Q	Real length from the M27	TTS (+1%) TTS (+0.2%) TTS (+0%)	Scariza (2003)
8	Micro-simulation using AIMSUN	ALINEA	∞	Capacity (+16%) Speed (+58%)	Sarintorn (2007)
9	Micro-simulation using CORSIM	D-C	∞	No congestion	Sisiopiku <i>et al.</i> (2005)
10	Micro-simulation using VISSIM	ALINEA Occupancy	Not given	TTS (increased)	Horowitz <i>et al.</i> (2005)
11	Macro-simulation using METANET	ALINEA	50 veh	TTS (-9.2%)	Papamichail and Papageorgiou (2008)
12			100 veh	TTS (-0.9%)	Bellemans <i>et al.</i> (2006)
13			30 veh for urban on-ramps and ∞ for ftf on ramps	TTS (-5%)	Papamichail <i>et al.</i> (2010)
14			∞	TTS (-45%)	
15			Micro-simulation using MITSIM lab	∞	TTSM (-23.6%) TTS (+ 8.5%)
16	Macro-simulation model	Extended PI-ALINEA	∞	No congestion	Wang <i>et al.</i> (2010)

## CHAPTER FOUR : DATA COLLECTION AND ANALYSIS

### 4.1. Introduction

This chapter shows the work which has been undertaken for collecting and analysing the data. The objective is to get a better understanding of drivers' behaviour and to use the obtained data in developing, calibrating and validating the simulation model. Data taken from motorway normal sections (i.e. far away from merge or diverge sections) have been mainly used to study the effect of the type of vehicles on the following distance behaviour, lane utilisation, arrivals (headways) of vehicles and frequency of lane changing. Data taken from merge sections have been used in studying some issues such as the position of merge, gap selection behaviour and the cooperative behaviour of motorway drivers. Some other data from ramp metering (RM) sites have been used in studying critical occupancy, compliance of drivers with RM signals and the effectiveness of RM systems in preventing traffic congestion.

### 4.2. Methods of data collection

Different methods of data collection of traffic parameters such as flow and speed have been reported in previous research. Video recording, loop detectors and radar speedometers are examples of these methods. The selection of the appropriate method depends on many factors such as availability and the accuracy of the given method. Using one method to collect all the required parameters accurately is not feasible. For example, using video recordings may provide reasonable data to estimate traffic flow, headway, lane utilisation and type of vehicles but it could not be applied for the estimation of time occupancy. Also, loop detectors can provide detailed information on traffic flow, average spot speed, vehicle length, lane utilisation and time occupancy; however they are not capable of providing, for example, vehicle type, the number of lane changes and the manoeuvring time for lane changing.

Instrumented vehicles have been used over the past decades in order to obtain some microscopic parameters such as the acceleration/deceleration rates of vehicles at small time intervals (see for example, Brackstone and McDonald (1993) and also Brackstone *et al.* (2009)). The accuracy of the extracted data provided by this technique is not influenced by human errors. However, the driver's behaviour of the instrumented vehicle may be affected since the driver may receive some information to follow a specific

route or vehicle type during the data collection process and also the driver is aware that he/she is monitored.

Recently, traffic studies have started to rely on data taken from loop detectors since such data are widely available and can be collected and analysed with less effort. The accuracy of data given by loop detectors is not affected by human errors, such as in the case of video recordings. Moreover, research focusing on traffic management controls (e.g. RM) depends on average one minute (or less) of traffic data which can be accurately measured by loop detectors. On the other hand, collecting data using video recordings from cameras may not be possible without getting some agreements from local authorities. In this study, both techniques of video recording and loop detectors were used. However, the use of video recordings was limited to obtaining the parameters which cannot be estimated from the loop detectors' data. In addition, some published data taken from instrumented vehicles as well as other resources were used in the calibration of the developed simulation model as will be discussed later in Chapter 6.

### 4.3. Site selection and description of the data obtained

Figure 4-1 illustrates the main classifications for the sites used (i.e. normal and merge sections) and the parameters that have been studied for these sites. Table 4-1 represents a summary of the data collected in this study, the sites details, duration and type of the data and finally the parameters obtained from the data. The next sections in this chapter describe these parameters.

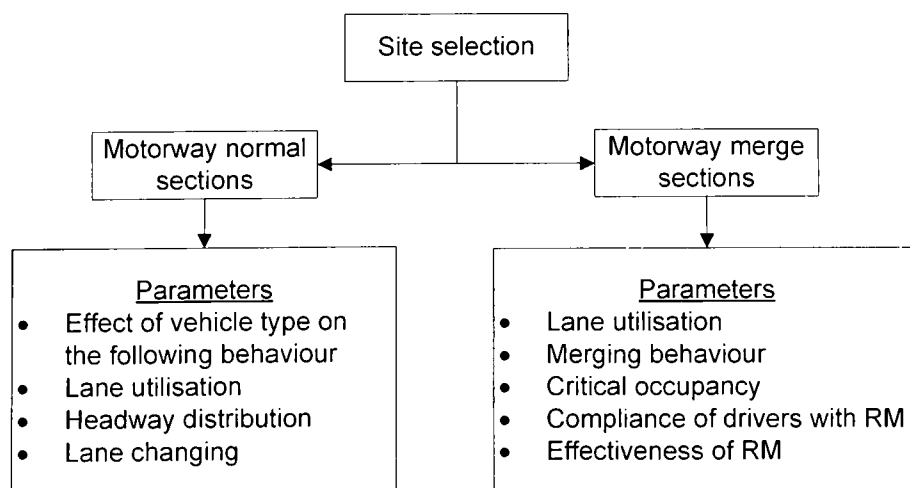

Figure 4-1 Summary of parameters studied

Table 4-1 Summary of the selected sites and how the data was used

Site	Site	Date	Duration	Type	Purpose
1	M60 J2	30/08/2009	2 hr (AM)	Video	-Position of merging
2	M60 J3		2 hr (AM)	Video	-Position of merging -Gap selection behaviour
3	M56 J2	14/09/2009 15/09/2009 08/10/2010	1 hr (AM) 1 hr (AM) 2 hr (PM)	Video	- Position of merging -Compliance of drivers with RM -Lane utilisation for ramp traffic
4	M60 J22	01/09/2009	30min (PM)	Video	Position of merging
5	M60 J10	19/03/2010	3 hr (PM)	Video	-Gap acceptance and gap selection behaviour - Position of merging -Cooperative behaviour
6	M60-M602 J12	17/03/20	90 min (PM)	Video	- Position of merging -Gap selection behaviour
7	M60 J22-J23 with 4 lanes	12/03/2010	3 hr (AM)	Video	-No. of lane changes
8	M60 J1-J2	15/03/2010	1 hr (PM)	Video	-No. of lane changes
9	M6 & M602	31/03/2009	2 hr (AM)	Video	-Manoeuvring time for lane changing
10	M56 J2, M60 J2, M6 J20 and M6 J23	27/04 to 01/05/2009	5 days	Loop detectors	-Critical occupancy
11	M25 normal section M42 normal section	4 to 18/5/2002 22/08 to 4/09/2002	14 days	Individual vehicles' data	-Lane utilisation -HGVs' lane utilisation -Vehicle types -Vehicle lengths' distribution
12	M602 (2 lanes)	14 to 18/6/2010	5 days	Loop detectors	-Lane utilisation
13		16/03/2010	2 hr (PM)	Video	-No. of lane changes
14	M62 (3 lanes)	1 to 7/6/2010	7 days	Loop detectors	-Lane utilisation

#### 4.4. Effect of vehicle types on “close following” behaviour

This section describes the work which has been carried out in order to test the effect of vehicle type on the clear spacing (following distance) as well as the time headway between successive vehicles. The aim is to get a better understanding of drivers' behaviour while following each other and also to test the validity of car following models, particularly for those models that use the size of vehicles (width) as a factor (such as the visual angle models (Hoffman and Mortimer, 1994).

Four “types of movements” are considered in this study similar to those adopted by Parker (1996). These are car following car (C-C), car following heavy goods vehicle (C-H), heavy goods vehicle following car (H-C) and heavy goods vehicle following heavy goods vehicle (H-H).

#### 4.4.1. Background

Drivers' "close following" behaviour is a noticeable phenomenon on motorways and it is a crucial factor when considering safe driving. Understanding how drivers control their vehicles in such situations requires more attention (Brackstone and McDonald, 2007).

In the context of this work "clear spacing" (in metres) and "gap headway" (in seconds) are terms used to describe the spacing from the rear of the leading vehicle to the front of the following vehicle. Also, the terms "clear spacing" and "following distance", which are both used by other researchers, are used in this work to give the same meaning. "Headway" or "time headway" (in seconds) is measured from the front of the leading vehicle to the front of the following one.

Several studies have dealt with the following distance according to the type of the leader/follower's vehicles. Some groups of researchers claim that the following distance between C-C is always less than that for the case of C-H while others have suggested the opposite. Researchers who have supported the use of visual angle car following models (see section 2.3.1) are examples of the first group. The other types of movements (i.e. H-C and H-H) have received little attention in previous research.

Parker (1996) examined the following distance between successive vehicles travelling in a platoon (assuming a maximum time headway of 5 seconds as a criteria for identifying platoons) on some sites where roadwork was being undertaken in the UK. The speed classes considered were 20-30 km/hr and 60-70 km/hr in order to represent lower and higher speeds at these sites. To estimate the following distance, average lengths of 4.2 and 11.2m for cars and HGVs respectively, were used. His results showed that the clear spacing for the case of C-H was slightly less than that in the case of C-C and also suggested that the following distance in the case of H-C was closer than in the case of H-H.

Yoo and Green (1999), based on a total sample size of 768,000, found that the following distance in the case of C-C was "slightly" 10% less than that in the case of C-H. The study did not exclude the "free following" cases from their data.

Sayer *et al.* (2003) compared the average following distance between the cases where the leader is a passenger car with the cases where the leader is a light truck for speeds higher than 64 km/hr. The study used 108 participants to drive an instrumented passenger car. To exclude "free following" cases from the data, the maximum headway of 3 seconds and the maximum difference in speed between the leader and the follower of 1.5 m/sec were used.

A total of 1845 cases were analysed to establish that light trucks were followed by 5.6m (0.19 sec) shorter than when passenger cars were followed.

Recently, Brackstone *et al.* (2009) used data from an instrumented vehicle to study the effect of the leader on the gap headway in urban and rural areas in the UK. Data were obtained from six primary drivers while they were driving an instrumented vehicle and 123 drivers while they were following the subject (instrumented) vehicle. A maximum following headway (gap headway) of 2 seconds was used while speeds were grouped for every 5 m/sec. Cases where the acceleration exceeded  $+0.6 \text{ m/sec}^2$  were ignored based on findings by Sultan (2000). The main finding of Brackstone *et al.* (2009) was that trucks/vans are followed by a shorter distance than that where cars are followed.

So far, no agreement has been reached on this subject. Table 4-2 summarises the main findings of the above studies for the cases of C-C and C-H. The type of data and the criterion used to distinguish between “free following” and “car following” behaviour are also described in the table.

Regarding the time headway, it seems there is conformity that the average time headway in the case of C-C is always less than that for the case of C-H. Wasielewski (1981), Cunagin and Chang (1982), Bennett (1994) and Parker (1996) are examples of studies which confirm this finding. The study by Wasielewski (1981) used a sample of 25,000 vehicles obtained from using a video camera for flow rates near to capacity and showed that the average time headway for C-C was found to be 5% less than that for C-H.

Table 4-2 Summary of some previous studies examining “close following” behaviour

Author	Type/source of data	Sample size	Maximum headway/spacing (m or sec)	Maximum speed difference (km/hr)	Speed range (km/hr)	Findings
Yoo and Green (1999)	Instrumented vehicle	768,000	(183 m) following distance		80	C-H > C-C (10%)
Sayer <i>et al.</i> (2003)	Instrumented vehicle	1,698	3 sec time headway	5.4 km/hr	>64	C-H < C-C (5.6 m)
Brackstone <i>et al.</i> (2009)	Instrumented vehicle	501	2 sec gap headway	3.6 km/hr	72-90 90-108 108-126	C-H < C-C
Parker (1996)	Videos from roadwork sites	7199	5 sec time headway	7.2 km/hr	20-30 60-70	C-H < C-C (slightly)

#### 4.4.2. Description of the data

A full 14 days of individual vehicles’ raw data (IVD), extracted from inductive loop detectors on sections from the so called ‘Managed Motorways’ (Klein and Barton, 2010) of

the M42 between Junctions 5-6 and the M25 between Junctions 15-16, are used. As shown in Table A-1 in Appendix A, the data represent speed, headway and length for each vehicle reaching the detector for each specific lane and direction. The whole data represent more than 4 million pairs of leader/follower cases. This readily available electronic data may be regarded to be more reliable than other sources of data, such as using instrumented vehicles, in terms of the size of the sample and the accuracy in estimating speeds, headways and length of vehicles. Moreover, drivers' behaviour will not be affected by this method of data collection as might be the case in using instrumented vehicles (see section 4.2).

#### 4.4.3. Methodology

This section describes the methodology that has been used to filter and analyse the data. The main purpose of the filtering process is to exclude any cases of "free flowing" conditions and concentrate on those cases with "close following" as well as identifying the type of vehicles. Further tests were carried out to show the effect of "following" (but not just "close following") behaviour. There might be cases where lane changes have occurred at the position of the loop detectors; however, this is likely to be minimal due to the limited area covered by these detectors and hence the low probability that this will happen at such locations.

##### *a. Defining vehicle types*

The types of vehicles are not readily obtained from the data provided (i.e. cars or HGVs). Therefore, and for the purpose of this study, it is important to define the type of each vehicle based on its length. The lengths of vehicles are investigated from typical manufacturers' data sources. Three main categories of vehicles are considered. These are cars, vans and HGVs. Table 4-3 represents a summary for the typical ranges of vehicle length commonly found on British roads for each of these categories (Yousif and Al-Obaedi, 2011).

Table 4-3 Typical ranges for lengths of vehicles (Source: Yousif and Al-Obaedi, 2011)

Vehicle type	Length (m)	Remarks
Cars	2.6-5.4	Limousine vehicles are not considered
Vans	3.4-6.4	Includes small vans
HGVs	5.6-25.5	Includes light goods' vehicles



While the table suggests a value of 5.4m as a limit between cars and HGVs, it is not possible, for example, to distinguish between cars and vans or between vans and HGVs just by the lengths of vehicles obtained from the loop detectors data. Therefore, and in order to satisfy the assumption that cars and HGVs are not combined in one group, it was decided to exclude any such uncertainty in the lengths of vehicles when trying to identify the type of vehicles. For this reason, a value of 4.5m has been used as a maximum length for cars and a value of 6.6m as a minimum length for HGVs. The second value of 6.6m for HGVs is used by the Highways Agency, UK to define HGVs. This means that any vehicle with a length between these two values is ignored and is not considered in the calculations in order to be certain that cars and HGVs are identified from the loop detectors data. Using a higher value of 7.0m to define HGVs' length as used by the Highways Agency's National Traffic Control Centre (NTCC) (TIS, 2003) has also been considered (see Yousif and Al-Obaedi, 2011). However, one could argue that excluding the vehicles which have lengths between 4.5 and 6.6m may bias the results. Therefore, other tests have also been carried out assuming that all vehicles with lengths of less than 6.6m are cars and all vehicles that have lengths higher than 6.6m are HGVs.

*b. Selection of maximum headway*

Vehicles travelling on a specific roadway section are either in free, following or emergency regimes (Yang and Koutsopoulos, 1996). A free vehicle is unaffected by the preceding vehicle due to either a large spacing between the vehicles or because the speed of the leader is reasonably higher than that of the follower. A following vehicle is forced to travel at a speed close to that of the leader due to absence of opportunities to overtake (Bennett, 1994). Therefore, maximum (critical) headway (Bennett, 1994) is the limit between the free and the following regimes. An emergency case happens when a vehicle is forced to travel with a headway less than the driver's desired one due to, for example, forced lane changing.

Different maximum headway values, expressed as time headway, gap headway or following distance, have been suggested according to previous research work as presented in Table 4-2.

For the purpose of this study, it is believed that drivers' decisions to accelerate or decelerate are mainly based on the clear spacing and relative speed between the successive vehicles. This assumption is supported by most of the existing car following models (see for example, Gipps, 1981 and Hidas, 1996). Moreover, the use of critical headway based

on the time headway criteria (i.e. front to front of vehicles), as used by the majority of previous studies, will result in ignoring the effect of vehicles' lengths on clear spacings between successive vehicles and hence affect drivers' behaviour. Also, real traffic data suggests that the length of vehicles have increased in recent years. Based on the above, a value of 2 seconds for the gap headway (as also used by Brackstone *et al.*, 2009) has been selected as the critical headway for "close following" behaviour.

In addition, other values of "following behaviour" were tested to eliminate cases of "free flowing" conditions. These include a maximum of 3, 4 and 5 seconds respectively to see if these will have any effect on the following distance between the selected "types of movements" This is supported by the fact that some drivers may follow the official Highway Code (2010) in which they were advised, for safety reasons, to leave a minimum of 2 seconds between themselves and the vehicle in front.

*c. Selection of maximum relative speed difference*

A value of 1.5 m/s (5.4 km/hr) was selected as the maximum relative speed difference between the leading and the following vehicles to identify the following behaviour. This value was suggested by other previous studies (see for example Sayer *et al.*, 2003) and Zhang and Bham, 2007) to represent the maximum speed difference at steady state conditions (car following regime). In addition, this value of 5.4 km/hr was considered to be reasonable in order to avoid those cases involving lane changing since the relative difference in speeds between vehicles in such cases were likely to be higher. Another criterion used in the analysis was to have a 10 km/hr maximum speed difference. The 10 km/hr value was selected based on the finding by Ferrari (1989) who suggested that drivers may prefer to stay in their lanes if the differences between their desired speeds and the speeds of their leading vehicles are within a value,  $R$  (in km/hr), which is equal to  $1040/\text{desired speed (km/hr)}$  as defined in section 2.3.2.

*d. Summary of the tested criteria*

As discussed above, different values to define the gap headways, the difference in relative speeds and vehicles types are selected in order to examine the following distance and headway behaviour. A summary of the selected criteria and the number of tests are shown in Table 4-4.

Table 4-4 Summary of selected criteria for tests

Test No.	Max gap headway (sec)	Max. speed difference (km/hr)	Vehicle type	
			Cars	HGVs
1	2	5.4	<=4.5m	>6.6m
2	3			
3	4			
4	5			
5	2	10.0	<=4.5m	>6.6m
6	3			
7	4			
8	5			
9	2	5.4	<=6.6m	>6.6m

e. *Analysing method*

As mentioned before, the raw data from the M25 and the M42 motorway sites combined all vehicles in all lanes and in both directions based on time events (see Table A-1 in Appendix A). Therefore, it is necessary to separate the successive vehicles according to their lanes and their directions.

There are limitations in the use of Excel spread sheets in analysing such large sample of data which represents more than 4 million pairs of leader/follower. The use of Excel spread sheets does not help in testing different scenarios such as those given in Table 4-4. Therefore, it was decided to write additional computer programs for the purpose of analysing the data.

A computer program (see Program 1 in Appendix B) using Compaq Visual FORTRAN-2005 was written and used to separate the data into files representing successive vehicles for each lane and for each site (e.g. see Table A-2 in Appendix A). These produced files have then been further analysed using another computer program (see Program 2 in Appendix B) to filter the data using the above described methodology (i.e. for vehicle type, critical headway and relative speed). The final outputs of the latter program (e.g. see Table A-3 in Appendix A) are the average speed, headway and following distance for each speed class interval and according to the "types of movements" leading vehicle's type (i.e. C-C, C-H, H-C and H-H). The clear spacing (in metres) between successive vehicles is obtained from the following equation:

$$\text{clear spacing} = (V_C h) - L_L \quad \text{Equation 4-1}$$

where,

h is the headway of the following vehicle (sec),  
 $L_L$  is the length of the leading vehicle (m), and

$V_C$  is the speed of the follower (m/s).

To compare the results among the referred “types of movements” for different speed ranges, the output results were grouped in 10 km/hr class intervals. This is lower than the value of 18 km/hr used by Brackstone *et al.* (2009) in order to provide a more detailed analysis. For the statistical analysis, the non parametric Kolmogorov-Smirnov (K-S) statistics is used in testing whether there is a significant difference between the various cases of following distances. This test compares the maximum difference ( $D_{\max}$ ) between two cumulative distribution functions with the critical value ( $D_{cr}$ ) which is either obtained from K-S tables or as shown in Equation 4-2 (Hayter, 2002).

$$D_{cr} = 1.36 \sqrt{\frac{n_1+n_2}{n_1n_2}} \quad (\text{for 95\% confidence level}) \quad \text{Equation 4-2}$$

where,  $n_1$  and  $n_2$  are the sample sizes.

*f. Errors in the data*

It should be noted that random sets of the results of this filtering process have been examined further for any errors or unusual/unexplained data. In general the results of the filtering process seemed logical. However, in relatively very few instances, the results showed that there have been cases where the headway reading between “successive vehicles” was very small (i.e. less than 0.2 seconds) involving, in some cases, high speeds for “successive vehicles”. In practice, this is not possible and a closer manual look into such abnormal cases indicates that the indicative loop detectors have failed to recognise that this involve trailers (i.e. one long vehicle) rather than two vehicles (a leader and a follower with such small headways). It should be noted that such error cases are expected to occur according to Slinn *et al.* (2005) who reported that the loops can fail to read a vehicle pulling trailer as one vehicle. Such minor cases were deleted from the final set of data which was used in the main analysis.

*g. Lanes to be considered*

To decide whether or not to combine the results for all the lanes together, initial tests were undertaken to compare the following distance for the case C-C on lane basis. The results presented in Figure 4-2 reveal that there are pronounced differences in the following distance among the tested lanes for speeds higher than 80 km/hr for both the M25 and the M42 data.

Drivers in the offside lanes and with speeds higher than 80 km/hr seem to leave a lower following distance than those drivers in the inside lanes. This behaviour is identical for both motorways as shown in the figure. Therefore, the results have been presented for each lane separately. For speeds lower than 80 km/hr, the average following distances were identical for all lanes. That indicates that drivers in congested situations maintain their minimum following distance since there are insufficient gaps in other lanes operating more or less with similar speeds (Sultan and McDonald, 2001). It should be noted here that Heydecker and Addison (2011) found similar need to consider the data from each lane separately when modelling the speed-occupancy relationship based on data from the M25 motorway under different speed limit values.

Since the offside lanes on motorways are not usually utilised by HGVs the data from these lanes (i.e. the third lane of the M42 and the fourth lane of the M25) have not been considered.

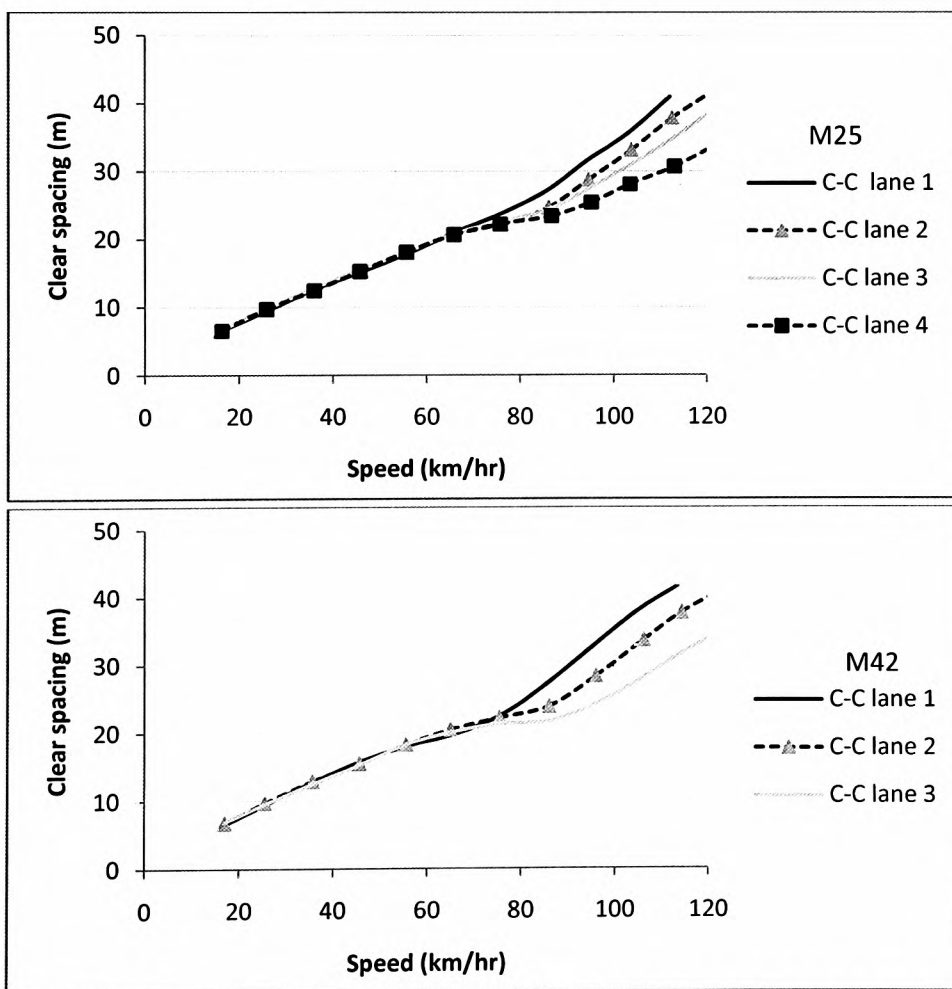

Figure 4-2 Following distance for C-C for each lane of the M25 and the M42

### *h. Size of the analysed sample*

While the initial data represent over 4 million cases, Table 4-5 and Table 4-6 represent the size of the remaining sample after filtering the raw data for the M25 and M42 for the tests given in Table 4-4.

Table 4-5 Size of the analysed sample with respect to the selected criteria for the M25

Lane No.	Case	Test No.								
		1	2	3	4	5	6	7	8	9
1	C-C	13497	17508	19609	20932	15814	21153	24266	26305	64459
	C-H	9360	12013	13407	14293	10933	14514	16576	17992	22053
	H-C	4577	6701	8284	9504	5822	8873	11306	13193	10619
	H-H	15144	22360	27793	32144	18633	28110	35571	41596	15144
2	C-C	56142	128134	76381	80270	69862	21153	99089	105242	170471
	C-H	16775	10002	21357	22100	19952	14514	26360	27539	30836
	H-C	9369	8166	14660	15950	11882	8873	19542	21565	17384
	H-H	9430	1856	13740	14687	11340	28110	17089	18424	9430
3	C-C	108920	99386	135947	139550	142440	171216	183900	190186	287948
	C-H	8632	1839	10511	10756	10305	12164	12894	13263	14985
	H-C	6818	1718	8783	9070	8601	10508	11437	11889	11870
	H-H	1577	80	1978	2026	1871	2254	2421	2487	1577
Total		260241	309763	352450	371282	327455	341442	460451	489681	656776

Table 4-6 Size of the analysed sample with respect to the selected criteria for the M42

Lane No.	Case	Test No.								
		1	2	3	4	5	6	7	8	9
1	C-C	37429	48465	54598	58610	49724	66338	76092	82648	58495
	C-H	19355	25222	28212	30027	24699	33210	37962	40916	25697
	H-C	8584	13050	16360	18787	12091	18994	24320	28389	11806
	H-H	21078	30372	37190	42201	27101	40011	49726	56896	21078
2	C-C	119775	146886	159860	166785	168867	212231	234433	246729	182538
	C-H	13034	15156	16069	16508	16823	20053	21554	22274	16816
	H-C	7450	9278	10299	10890	10372	13324	15068	16055	9712
	H-H	4275	5009	5402	5645	5427	6501	7087	7435	4275
Total		230980	293438	327990	349453	315104	410662	466242	76092	330417

#### 4.4.4. Results and discussion

The results presented here are just for the case of “close following” behaviour corresponding to test No.1 (see Table 4-1). The numerical results for the all tests given in Table 4-1 are presented in Table A-4 to Table A-21 in Appendix A.

For the M25 data, Figure 4-3 compares the average following distance and the average headway between the cases of C-C and C-H. Figure 4-4 compares the cases of H-H and H-C. Similarly, the results from the M42 are presented in Figure 4-5 and Figure 4-6. In general, these figures show that the average following distance increases with increasing of the average speed.

For the differences in the following distance, Figure 4-3 to Figure 4-6 suggest that there are no significant differences in the average following distance between the cases of C-C and C-H and also between the cases of H-H and H-C. In most cases, only slight differences were observed (not exceeding 4%) for speeds higher than 80 km/hr. In addition, identical results were obtained for speeds lower than 80 km/hr.

For the differences in the time headway, the results are in agreement with previous studies as the average time headway for the cases of C-C is lower than the cases of C-H. This is found to be so for all the tested scenarios which is due to the fact that HGVs are longer than cars. For example, the results in Figure 4-3 for lane 1 suggest that the differences are about 1.8 seconds at 20 km/hr, 0.9 sec at 40 km/hr and 0.45 sec at 80 km/hr. These differences are consistent with the time required to travel a distance equivalent to the difference between a typical length of an HGV and that of a car (i.e. of about 10m) at such speeds. The same applies for other lanes (e.g. lanes 2 and 3 of the M25). However, there are smaller differences in the time when HGVs are involved for lanes 2 and 3 when compared with those for lane 1 (as shown in Figure 4-3). This could be attributed to the fact that the typical length of HGVs using lanes 2 and 3 of the M25 are likely to be lower than those in lane 1.

Table 4-7 and Table 4-8 show the numerical differences in the average following distance between the cases of C-C and C-H and also between the cases of H-C and H-H for the M25 and the M42 respectively. The Kolmogorov-Smirnov test suggested minimal cases where there are significant differences in the cumulative distributions (see the emboldened and underlined values in the tables). Figure 4-7 shows examples for the cumulative distributions of the following distances based on data from lane 1 of the M25 for average

speeds of 65, 75, 85 and 95 km/hr. The figure suggests similar cumulative distribution for the cases of C-C and C-H.

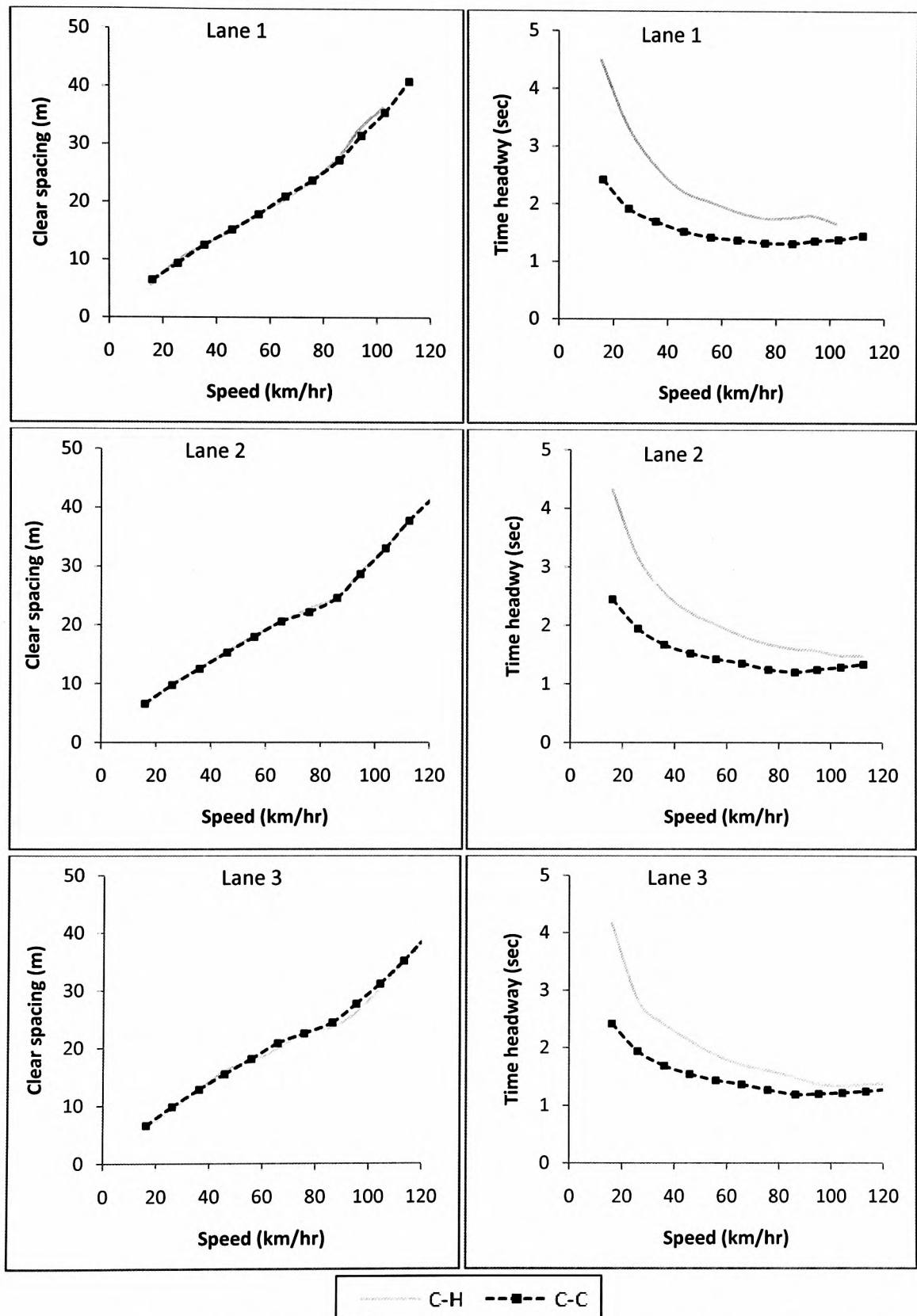

Figure 4-3 Comparing the following distance and the following headway between the cases of C-C and C-H using data from the M25 for test No.1



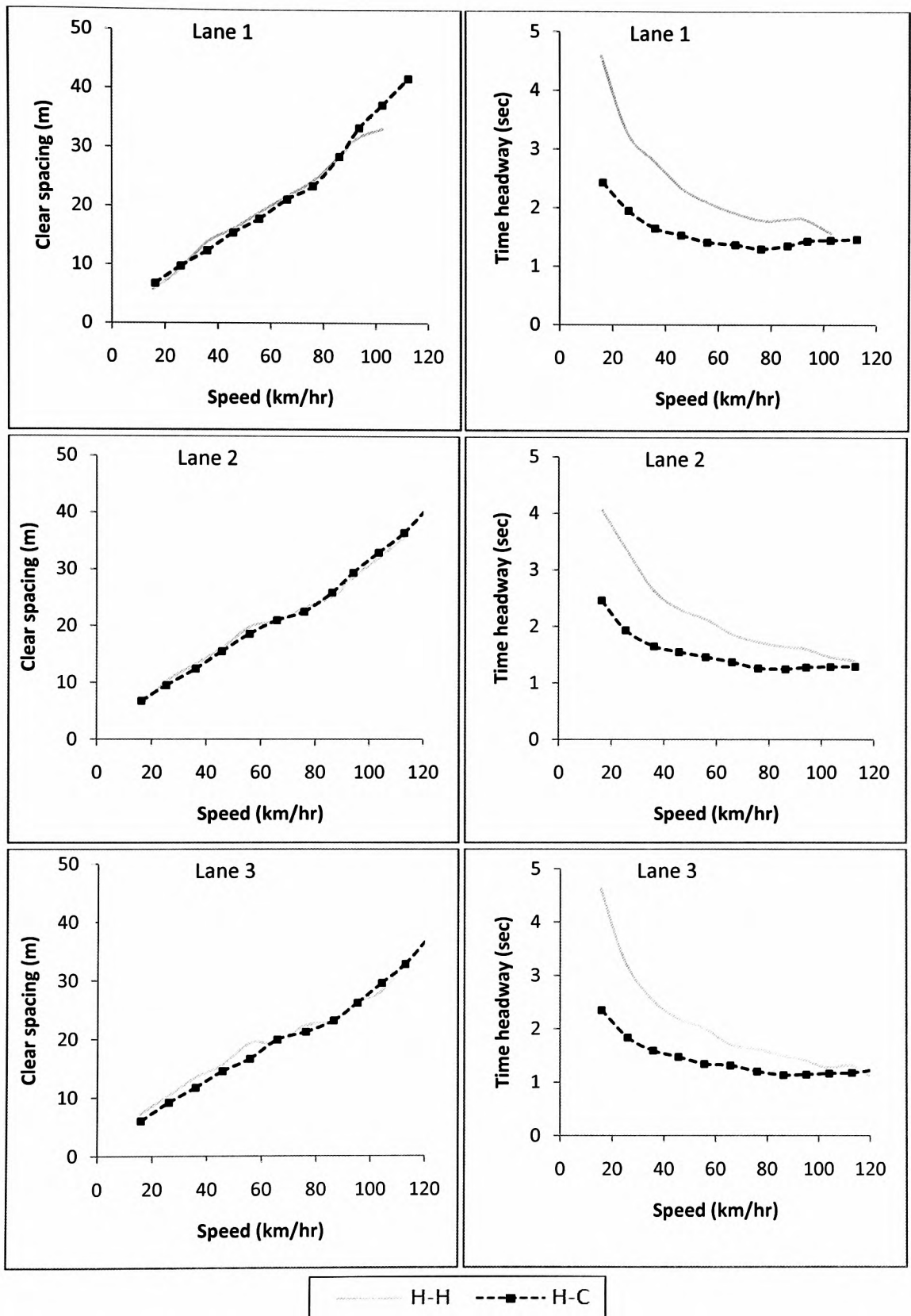

Figure 4-4 Comparing the following distance and the following headway between the cases of H-H and H-C using data from the M25 for test No.1

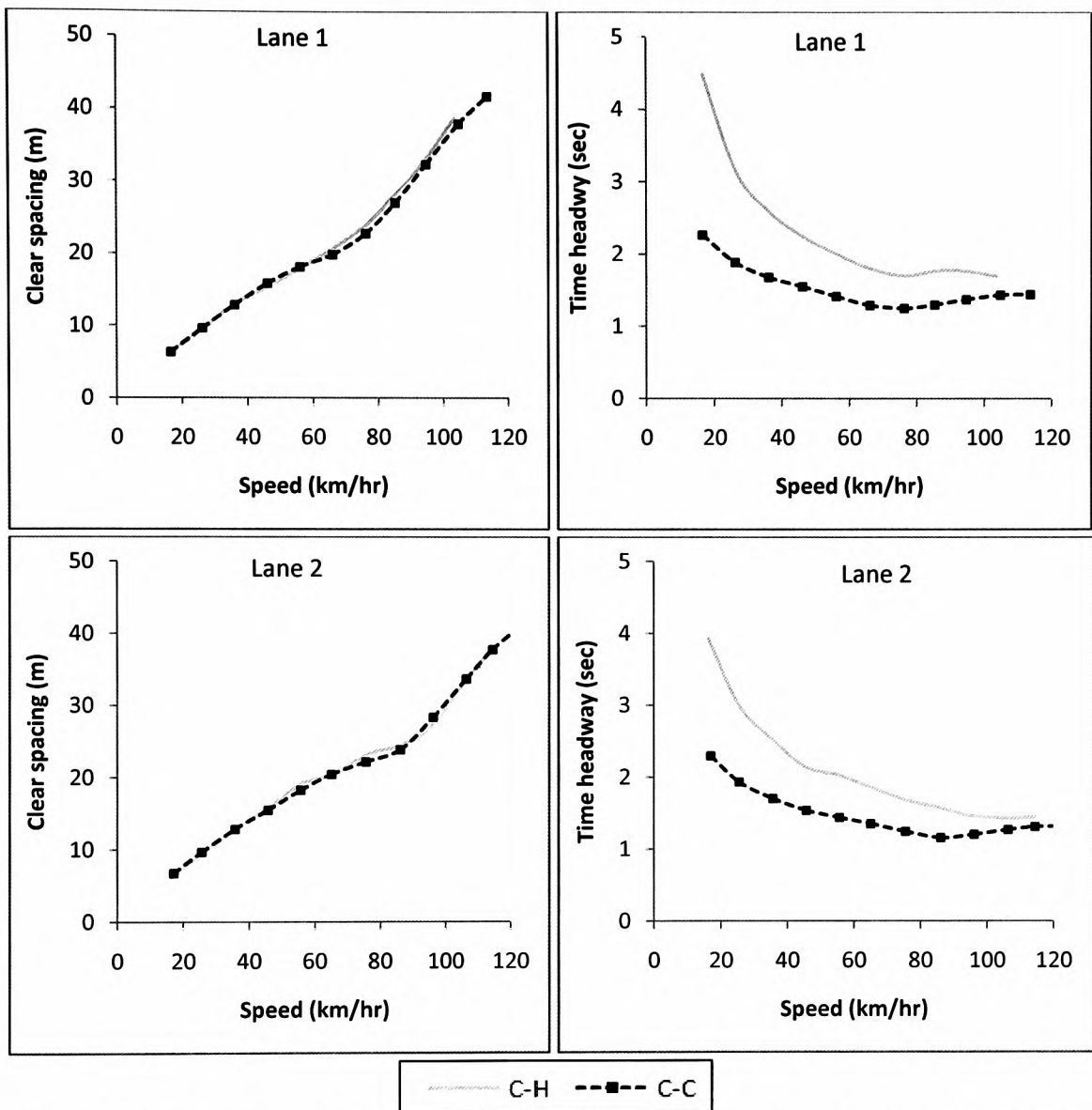

Figure 4-5 The following distance and the following headway between the cases of C-C and C-H using data from the M42 for test No.1

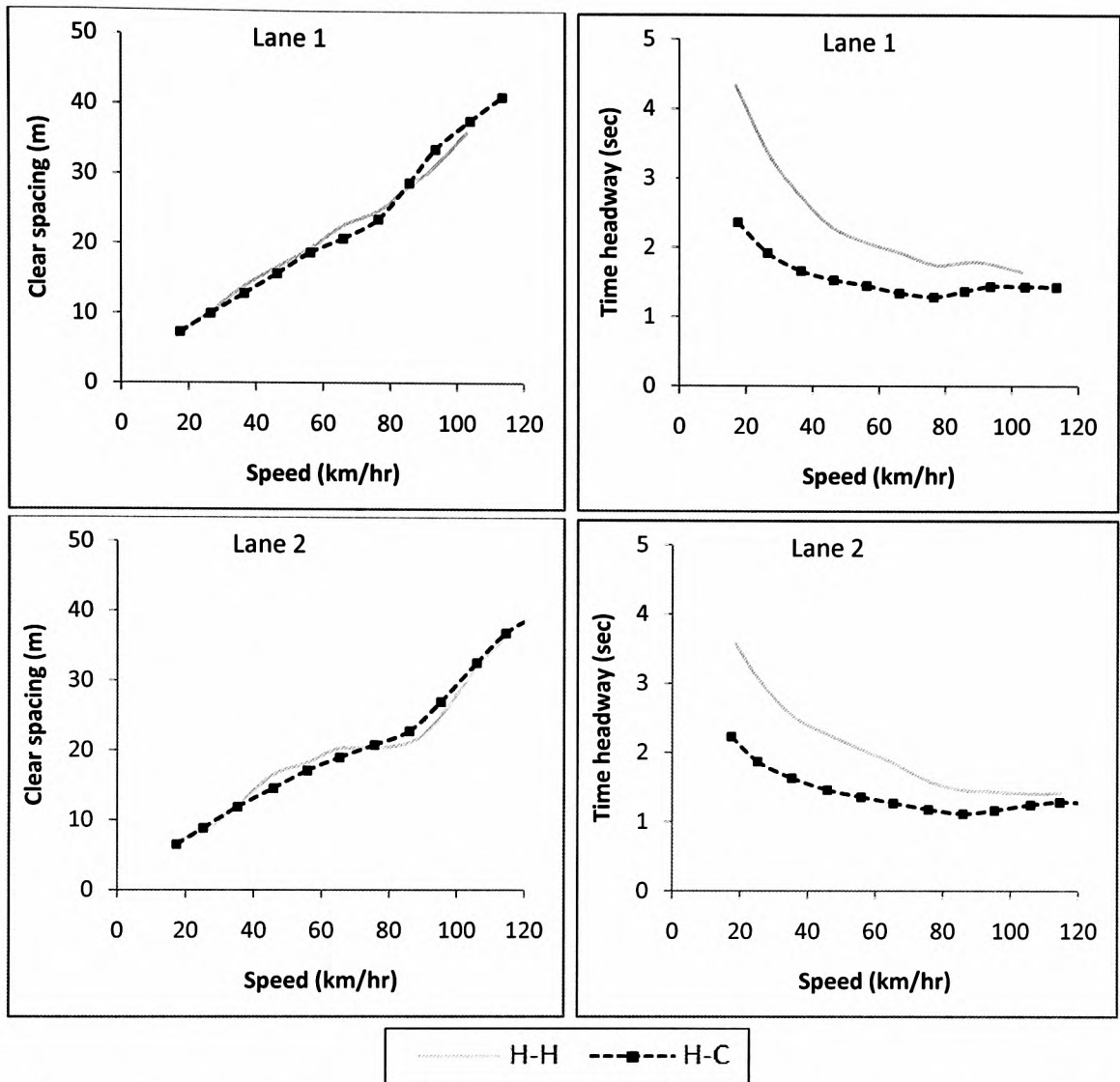

Figure 4-6 The following distance and the following headway between the cases of H-H and H-C using data from the M42 for test No.1

Table 4-7 Differences in the average following distance (m) for test No.1 for the M25

Lane No.	Case	Speed class (km/hr)										
		10-20	20-30	30-40	40-50	50-60	60-70	70-80	80-90	90-100	100-110	110-120
1	(C-H)-(C-C)	-0.86	0.43	0.06	-0.21	0.01	-0.37	0.13	0.86	<u>1.17</u>	0.81	2.03
	(H-H)-(H-C)	-1.04	-0.63	1.46	0.7	<u>1.09</u>	0.51	<u>1.1</u>	0.51	-1.75	-4.06	-8.34
2	(C-H)-(C-C)	-0.51	0.02	0.22	0.14	0.26	-0.04	0.6	0.18	-0.08	-0.49	0.04
	(H-H)-(H-C)	-0.47	0.92	0.84	0.54	1.27	-0.1	<u>0.66</u>	-0.59	-1.14	-1.07	-0.81
3	(C-H)-(C-C)	-0.47	-0.15	-0.25	0.45	-0.45	-0.88	0.08	-0.7	<u>-1.71</u>	<u>-1.15</u>	-0.28
	(H-H)-(H-C)	1.2	0.88	1.72	0.99	2.69	-0.63	1.07	-0.09	0.18	-1.6	0.55

Table 4-8 Differences in the average following distance (m) for test No.1 for the M42

Lane No.	Case	Speed class (km/hr)										
		10-20	20-30	30-40	40-50	50-60	60-70	70-80	80-90	90-100	100-110	110-120
1	(C-H)-(C-C)	0	-0.15	0.06	-0.47	-0.23	0.8	<u>1.22</u>	<u>1.43</u>	-0.18	0.8	-2.69
	(H-H)-(H-C)	-0.57	0.4	0.9	0.71	0.54	<u>1.83</u>	<u>1.25</u>	-0.26	<u>-2.79</u>	-1.71	-2.05
2	(C-H)-(C-C)	-0.59	-0.4	0.01	0.23	0.82	-0.02	1.04	0.59	<u>-1.65</u>	-0.56	0.27
	(H-H)-(H-C)	0.76	-0.51	0.26	1.93	1.14	1.24	-0.39	<u>-1.64</u>	<u>-3.07</u>	-0.8	-0.39

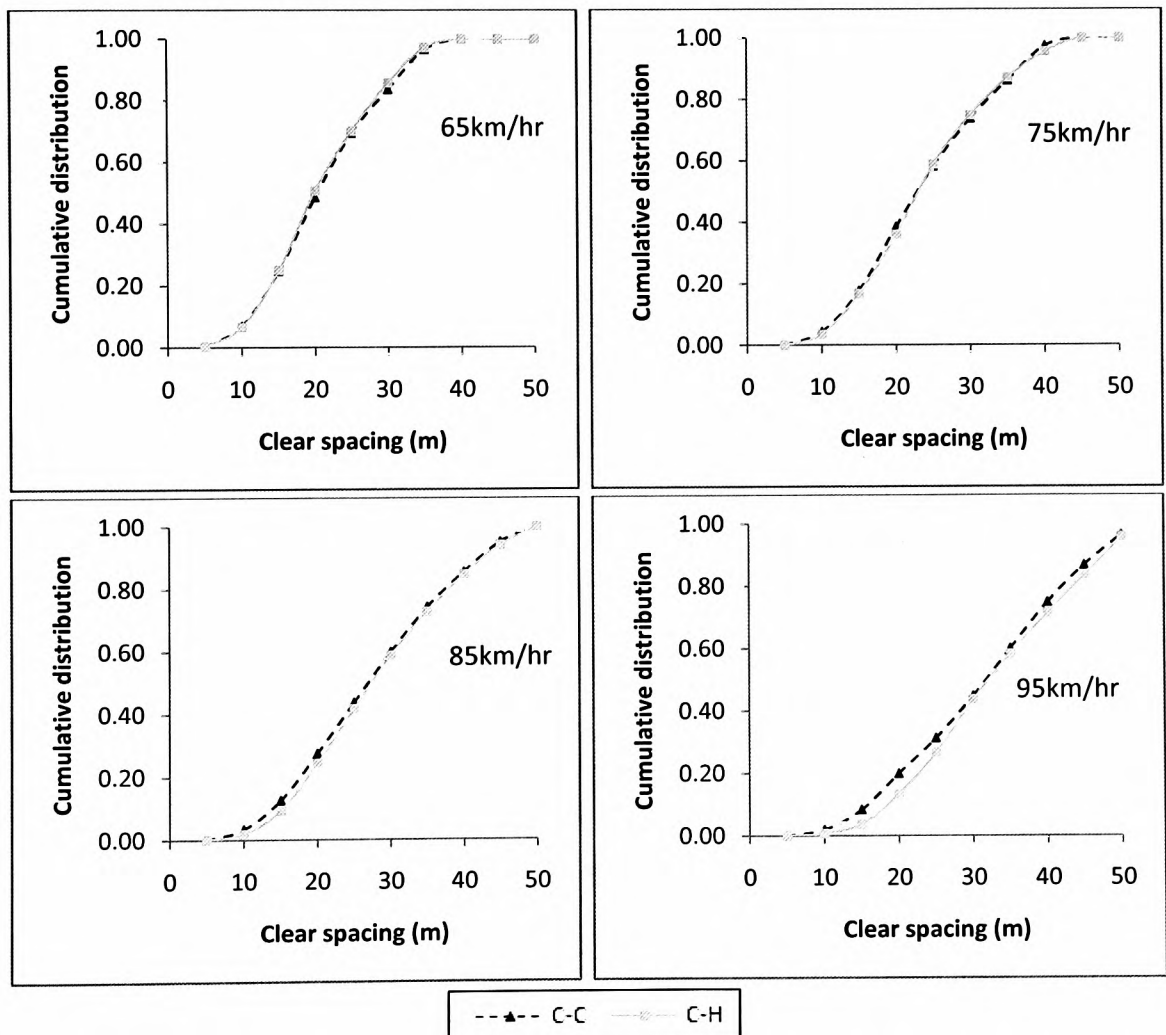

Figure 4-7 Examples for the cumulative distribution of the following distances based on the M25 data

The results for the other following behaviour tests 2 to 9 given in Table 4-4 (see Table A-4 to Table A-21 in Appendix A and also see Yousif and Al-Obaedi, 2011) suggest similar findings as there is no significant difference in the following distance between the cases of C-C and C-H.

The reasons for having no significant difference in the clear spacings for C-C and C-H may be related to the fact that HGVs (in general) require longer emergency braking distance than cars. This may result in reducing the safe following distance required for the case of C-H. This approach is used by researchers who developed safety car following models such as Gipps (1981) and Benekohal (1986). Other reasons may be due to the general improvements in power braking used for cars in recent decades. Although there is research in this area, more is needed to investigate the effects of such improvements as well as the factors relating to, for example, the use of cruise controls and other sensors and gadgets used while driving. This is beyond the scope of this work.

When comparing the results concerned with the following distance, these findings are in some disagreement with other studies. For example, Parker (1996), Sayer *et al.* (2003) and Brackstone *et al.* (2009) suggested that C-C is higher than C-H, while Yoo and Green (1999) suggested the opposite. The reasons for such differences might be attributed to the following:

- Some studies did not test the following distance for all ranges of speeds. For example, Parker (1996) tested just two ranges of speed, 20-30 km/hr and 60-70 km/hr, and the study by Sayer *et al.* (2003) examined only the cases where speeds are higher than 64 km/hr. In addition, there are some differences in selecting the value for critical headways between successive vehicles. However, the trend of the results did not significantly vary according to speed ranges.
- All the referred studies combined the data from all the lanes together. This may influence the results since Figure 4-2 suggests that the following distance is significantly different among the tested lanes.
- The study by Yoo and Green (1999) did not exclude "free following" cases from the given data (which is the purpose of this study). Therefore, the findings of Yoo and Green's work should be treated with care.
- The sample size of the data used in previous studies to compare the following distance is much less than that used in this study (see Table 4-2 and Table 4-5).
- Most studies (except the study by Parker (1996)) used instrumented vehicles where the drivers may be informed (alerted) about the purpose of the study and/or the behaviour of such drivers may influence the results.
- In estimating the following distance, the study by Parker (1996) used fixed values of 4.2 and 11.2m for lengths of cars and HGVs, respectively. This may influence the

results given for clear spacing since real data (as will be discussed later) suggests a range of values up to 25m for HGVs.

From the above, it can be said that the effect of the sample size used and considering the data obtained on each lane are more tenable in giving a firm conclusion on the results obtained. However, one should not ignore other factors such as the methodology used in collecting and analysing the data which could influence the accuracy of the results.

These findings are in disagreement with the basic assumption and concept of the visual angle car following models (where the spacing for the cases of C-H is supposed to be higher than that for C-C as discussed in section 2.3). This will have a negative impact on the validity of this assumption and hence on the use of visual angle car following models to represent real traffic behaviour.

#### 4.4.5. Comparison with other models

The following distance has been compared with some of the theoretical models which are recommended to specify the spacings between successive vehicles. These models, which are similar to those used by Huddart and Lafont (1990), include:

- The “natural relationship” from the Smeed and Bennett (1949) which is derived from real observations such as:

$$H = 5.34 + 0.22V + 0.000942V^2 \quad \text{Equation 4-3}$$

where,

H is the space headway (front to front, m), and

V is the average speed (km/hr).

- Leaving a safe stopping distance “S.S.D” as advised by the Highway Code (2010) assuming that the leading vehicle has already stopped.
- The “2 seconds’ rule” as a minimum clear spacing between vehicles as recommended by the Highway Code (2010). The clear spacing, in metres, is obtained from the following equation:

$$\text{clear spacing} = 0.55V \quad \text{Equation 4-4}$$

- The use of “white marker chevrons” at specified distances (about 38m apart) with signs advising drivers to leave the equivalent of 2 chevrons apart when following each other regardless of the speed value.

A part of the “natural relationship”, all of the above models are theoretical. Figure 4-8 compares the following distance, for the case of C-C, obtained from the above models and the middle lane (lane 2) of the M42 (based on maximum headway criteria of 2 and 3 seconds). The following distance for the “natural relationship” is obtained by subtracting the average cars’ length of 4m (as reported by the Highway Code (2010)). The figure shows that not one of the theoretical models (i.e. S.S.D, “2 seconds’ rule” and “2 chevrons’ rule”) could replicate the actual following distance. The “natural relationship” is relatively closer to the real data particularly for the data based on the 2 seconds headway criteria.

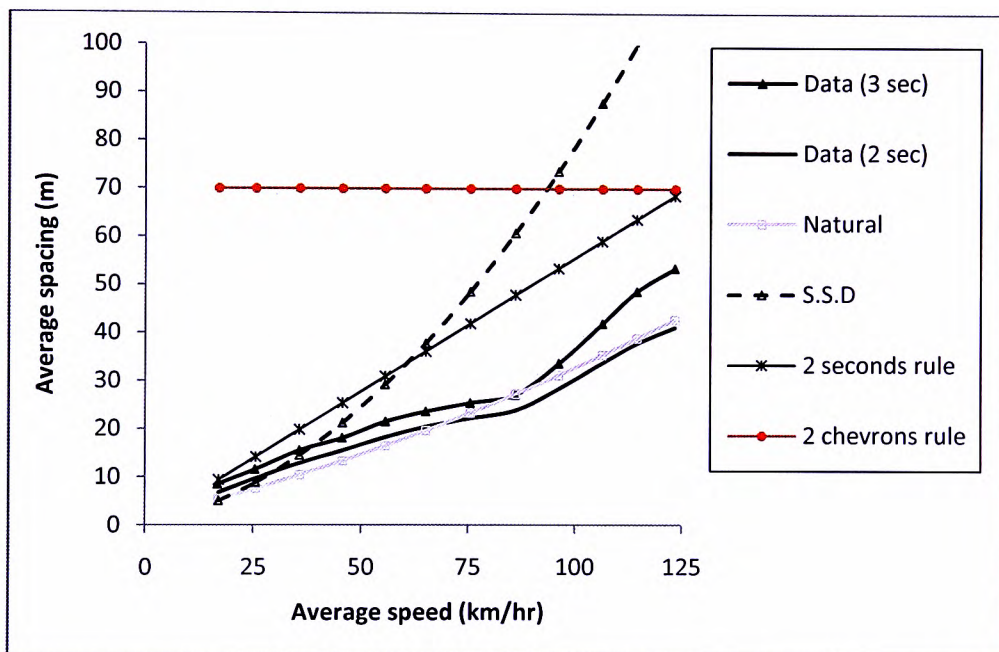

Figure 4-8 Observed average following distance with speeds compared with other theoretical models

## 4.5. Lane utilisation

### 4.5.1. Introduction and background

Lane distribution (lane utilisation, sometimes referred to as lane split) represents how traffic flow is distributed among the available number of lanes for a directional movement (Highway Capacity Manual (HCM), 2010). In most of the micro-simulation models, total section flow is used as input data and it is distributed amongst the lanes either by inputting these flows per lane or by using specific lane utilisation equations (models). Also, lane utilisation is one of the parameters used in the validation process of such micro-simulation models when some studies compare the simulated lane utilisation coefficients with real data (see, for example, Wall and Hounsell, 2005).



Many studies (see, for example, Yousif and Hunt (1995) and Brackstone *et al.* (1998)) have dealt with the subject and stated that for motorway segments far away from merge or diverge sections, vehicles are distributed based on total traffic flow ( $q$ ). The locations of the merging, diverging and weaving sections may affect lane utilisation (Jin, 2010). Nordaen and Rundmo (2009) and Ozkan *et al.* (2006) suggested that drivers' behaviour is significantly affected by cultural differences among countries. This might explain the differences in the pattern of lane changes for different countries as reported by Ferrari (1989). Gunay (2004) in his study on Turkish highways, also reported that the lane utilisation coefficients are significantly different from those obtained in developed countries. Gunay explained the reasons behind that behaviour by the so-called "untidy lanes" where no marking lines between lanes were present with poor lane discipline.

The Highway Capacity Manual (2010) suggested that, in general, lane utilisation depends on many factors such as traffic regulation, traffic composition, speed and volume (flow rate), the number of, and the location of, access points, the origin-destination patterns of drivers and drivers' behaviour.

Some studies (see, for example, Knoop *et al.* (2010) and Lee and Park (2010)) considered lane utilisation as a function of traffic density. However, this approach has its drawback in that traffic density is not directly measured by the loop detectors which are commonly installed on motorway sections to detect traffic.

Lane utilisation for heavy goods vehicles' (HGVs) traffic has received less attention in previous research. This may be due to a lack of sufficient traffic data to deal with this factor. One of the earlier reported trials to model the distribution of HGVs per lane was by Hollis and Evans (1976). Their study was based on the video recording of data collected from five motorway sites in the UK. As a total, 714 hourly flows were used for a period from 1966 to 1973. The distribution of HGVs on motorway lanes was assumed to be a function of the total HGVs' flow ( $q_h$ ) only and no HGVs were assumed to be in the third lane or in any higher lanes.

Turner (1983) included the individual effect of HGVs' flow ( $q_h$ ) and total directional flow ( $q$ ) on HGVs' lane utilisation. Fwa and Li (1995) studied HGVs' lane utilisation in Singapore for pavement design purposes. As in Turner's study, Fwa and Li (1995) considered the individual effect of  $q$  and  $q_h$  without studying the combined effect of these two parameters. The levels of HGVs' flows which were considered by Hollis and Evans (1976) and Turner (1983) were up to 1000 veh/hr. The study by Fwa and Li (1995)



considered HGVs' flows up to 200, 400 and 1000 veh/hr for sections with 2, 3 and 4 lanes, respectively.

In the UK, the Design Manual for Roads and Bridges (as shown on the Highways Agency's website, 2011) provides charts to predict commercial vehicle (HGVs) lane use for the nearside (lane 1) based on total commercial vehicle traffic per day (cv/day). These charts are currently being used in the design of highway pavement thickness to predict the "design traffic" in million standard axles (msa) for typical commercial vehicles in the "heavily" used lane (i.e. lane 1) within the design life of the highway.

In this study, new models for traffic lane utilisation as well as HGVs' lane utilisation have been developed using a large traffic database taken from different motorway sites. The development of such models will help in providing more realistic predictions of lane utilisation for use in micro-simulation traffic models and in the assessment of the proportions of commercial vehicles (HGVs) using the lanes for pavement design purposes.

#### **4.5.2. Lane utilisation for motorway traffic at normal sections**

Motorway Incident Detection and Automated Signalling MIDAS data were used to develop regression lane utilisation models. The data were taken from locations which are reasonably far away from merge and diverge sections (with no work zones or incidents) to reduce the effect of such conditions on the behaviour. Data from the M602 motorway with two lanes and the M62 motorway with three lanes were used. In addition, individual vehicles' raw data taken from loop detectors on the M25 motorway were used to represent lane utilisation models for motorway sections with four lanes. The data used were averaged for every five minutes' interval and a filtering process was conducted to ignore any anomalies in the data (e.g. durations of incidents when certain lanes were closed temporarily for a short period of time).

##### **4.5.2.1. Testing of previous models**

Regression analysis was used in modelling the available data. In the first instant, some of the previously developed models for lane utilisation have been tested using the existing data available for this work. The reason for doing so was to evaluate the validity of such models in representing lane utilisation for the relatively extensive data available from UK motorways. It should be noted here that motorways in the UK have speed limits of 70 mph (equivalent to 110 km/hr) for cars and 60 mph (equivalent to 100 km/hr) for HGVs; also HGVs are restricted from driving in the offside lane and drivers are allowed to

overtake (rather than undertake) when trying to improve their speeds and positions. These conditions might differ from other countries and such differences might affect and influence lane use. Therefore, the comparisons shown in Table 4-9 are restricted to previous UK studies and any of the recommended models in this study should be used with care if applied in other countries with different driving regulations. The details of the models and the test results (i.e. coefficient of determination values,  $r^2$ ) are as shown in Table 4-9. These  $r^2$  values were obtained using the Statistical Package for the Social Sciences (SPSS) software based on the actual and predicted lane utilisation coefficients.

Table 4-9 Testing some of the previous lane utilisation models (using existing traffic data)

Reference	Number of motorway lanes	Lane	Lane utilisation model (%)	$r^2$
Yousif and Hunt (1995)	2	1	$P1=87.04 - 0.036q + 5.91E-6q^2$	0.93
		2	$P2=100 - P1$	0.93
Yousif and Hunt (1995)	3	1	$P1=608.84q-0.39$	0.86
		2	$P2=100 - P1 - P3$	0.34
		3	$P3=0.034 + 0.0179q - 1.85E-6q^2$	0.92
Brackstone <i>et al.</i> (1998)	3	1	$P1=1756.5q^{-0.5253}$	0.82
		2	$P2=385.47q^{-0.2699}$	0.32
		3	$P3=0.0244q^{0.8791}$	0.96
Zheng (2003)	3	1	$P1=0.67106-2.4168E-4q-2.9302E-8q^2$	0.89
		2	$P2=0.4795 - 1.052E-5q - 3.018E-9q^2$	0.02
		3	$P3=-0.15061+2.522E-4q+2.6284E-8q^2$	0.92

For motorway sections with two lanes, it seems that the models developed by Yousif and Hunt (1995) are still applicable as these models gave good correlations with real data (i.e.  $r^2=0.93$ ). However, further attempts were made to test whether such models could be improved further using the existing data for the M602 motorway.

For motorway sections with three lanes, all the presented models in the table suggested good correlation between the data and the models for lanes 1 and 3 (i.e. all were higher than 0.80). However, for lane 2, all of the presented models were not adequately capable of modelling the lane utilisation for this lane (i.e.  $r^2$  values were around 0.30 and in the case of Zheng's (2003) model it was as low as 0.02). This could be due to some limitations in the original data available in producing those models (e.g. the sample size might be low for certain levels of flow). Therefore, it was felt necessary to consider the cases of three lanes to model lane utilisation using the existing data.

For four-lane sections, no reliable published work was found from the UK to model such lane use. Therefore, available data on these sections were analysed for this purpose.

#### 4.5.2.2. Development of new regression models

For the M602 motorway with two lanes, Figure 4-9 shows the lane utilisation for both lanes with corresponding regression models and coefficient of determinations ( $r^2$ ). As the flow rate increases, the utilisation of the inside lane (lane 2) increases rapidly until there is a similar use of lanes at around 2000 veh/hr. After that, lane 2 will ultimately have around 60% share of use at flows close to capacity. This is different from the finding of Wu (2006) who suggested that lane 2 within German autobahn sections (with two lanes) will start carrying flow rates higher than lane 1 when the total flow exceeds a value of about 1300 veh/hr. Figure 4-10 highlights the differences in lane use behaviour between the UK and Germany. Such differences may be due to the fact that there are differences in the way speed limits are implemented. Moriyama *et al.* (2011), for a 2-lane expressway in Tokyo, reported a similar lane utilisation pattern to that found in the UK.

Figure 4-11 and Figure 4-12 show the lane utilisation for the M62 motorway (with three lanes) and for the M25 motorway (with four lanes). The figures indicate that vehicles usually concentrate on the lower speed lanes for relatively low traffic flows operating under free flowing conditions (i.e. up to about 500 veh/hr), then other lanes start to have their share of use as traffic flow increases. When these flows are close to the capacity of the motorway, more even use of the lanes occurs. However, that does not mean that the number of vehicles in each lane is equal at such levels of flow.

Data from the M42 (Managed Motorway) with three lanes, with narrower lanes than those for normal 3-lane sections such as the M62 motorway, were also available for comparison. An attempt was made to check the validity of the proposed lane utilisation models for the M42 motorway data and to compare them with that of the M62 motorway data in order to see if the narrow lanes had a significant effect on lane use. The best fitting model for the M42 data gave  $r^2$  values of 0.946, 0.708 and 0.956 for lanes 1, 2 and 3 respectively. Similar  $r^2$  values were obtained by applying the models derived from the M62 data on the data taken from the M42 motorway. In this case, the  $r^2$  values were 0.946, 0.672 and 0.952 for lanes 1, 2 and 3 respectively indicating the validity of the developed regression models from the M62 with other sections. This also indicates that the effect of having narrow lanes, such as in the case of the M42 motorway, has a negligible effect on lane utilisation.

In order to exclude the effect of congested periods (i.e. when queues were formed and stop-start conditions occurred), the existing data were filtered to eliminate such periods. This was done by deleting data associated with such periods when there was a drop in traffic speeds from the analysis. The results suggest that there has been no significant change in the  $r^2$  values and to the regression model parameters which have already been presented in the previous section. This could be due to the fact that data points representing those periods of congestion were relatively small when compared with the whole data representing non-congested conditions.

An attempt was also made to analyse the data based on one minute intervals rather than five minutes in order to reduce the effect of speed and traffic density variations on lane use as much as possible. The results of this scenario gave more scatter and produced lower  $r^2$  values than those reported above. Therefore, and for practical reasons, only total flow has been considered and the above reported regression models are suggested for use.

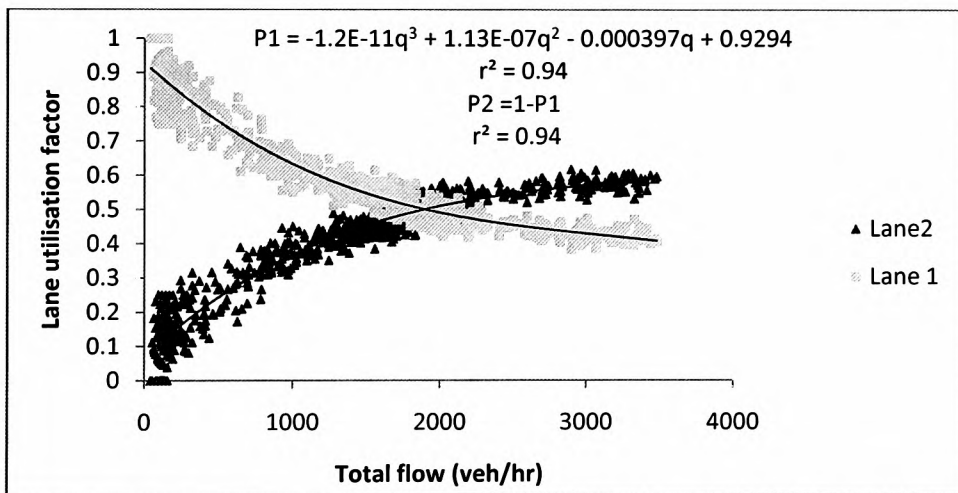

Figure 4-9 Lane utilisation for the M602 motorway (two lanes)

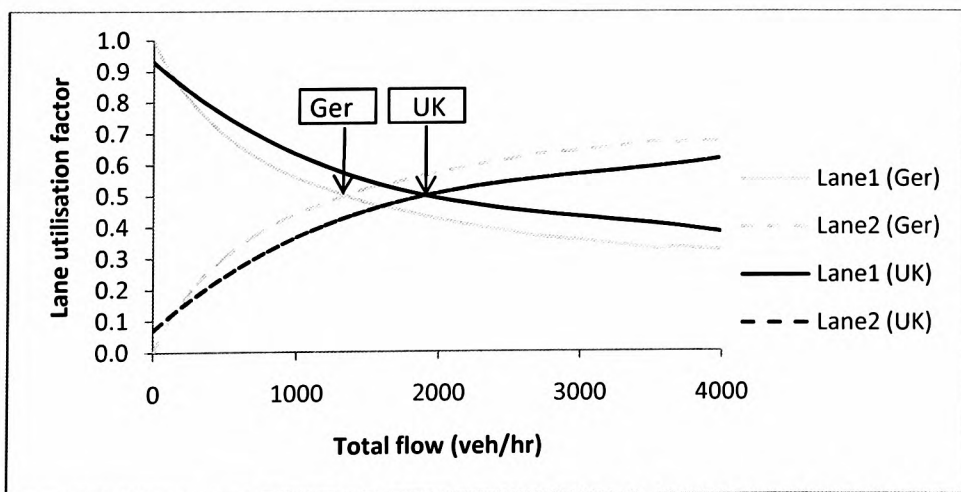

Figure 4-10 Lane use behaviour in the UK and Germany (Ger) for sections with 2 lanes

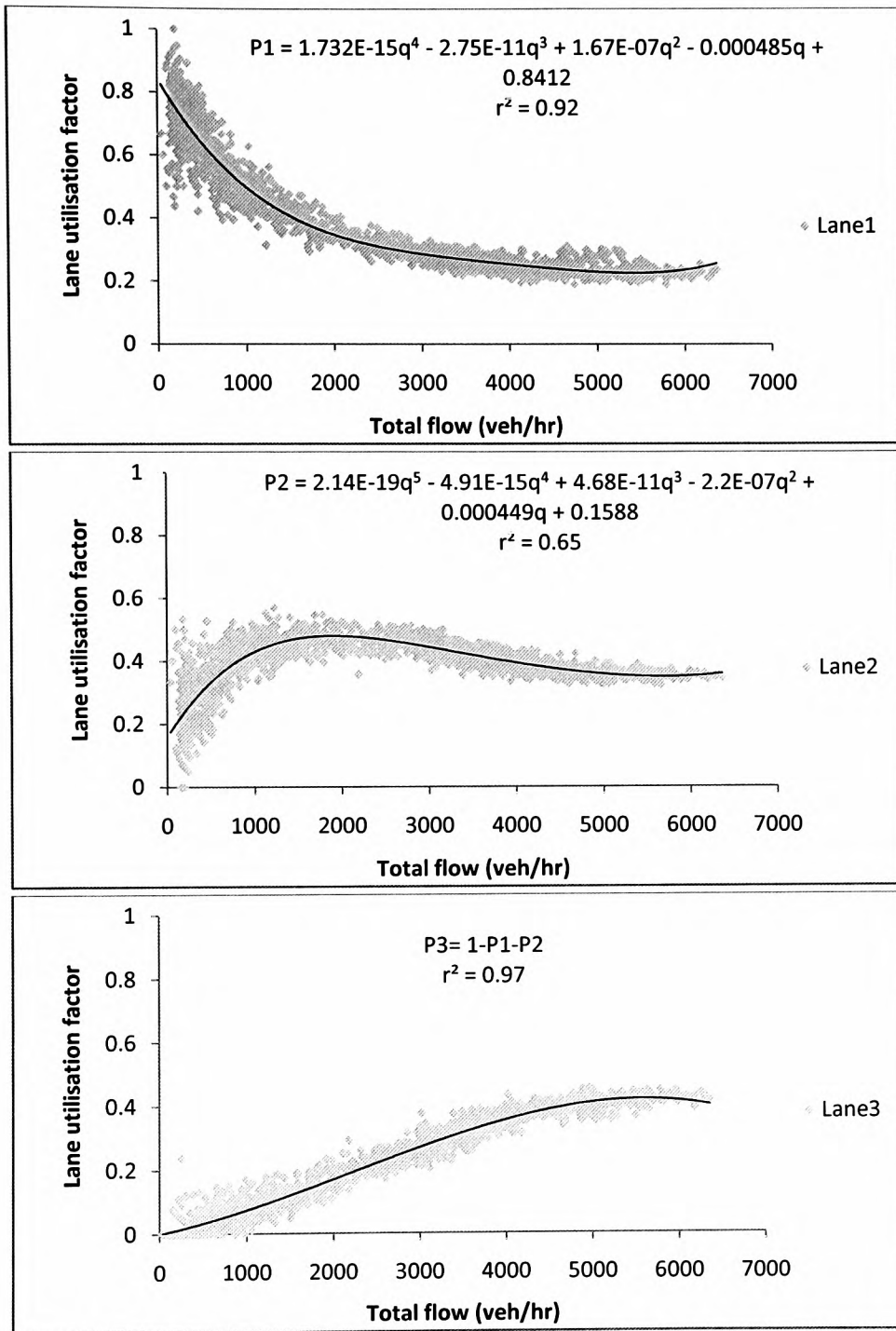

Figure 4-11 Lane utilisation for the M62 motorway (three lanes)

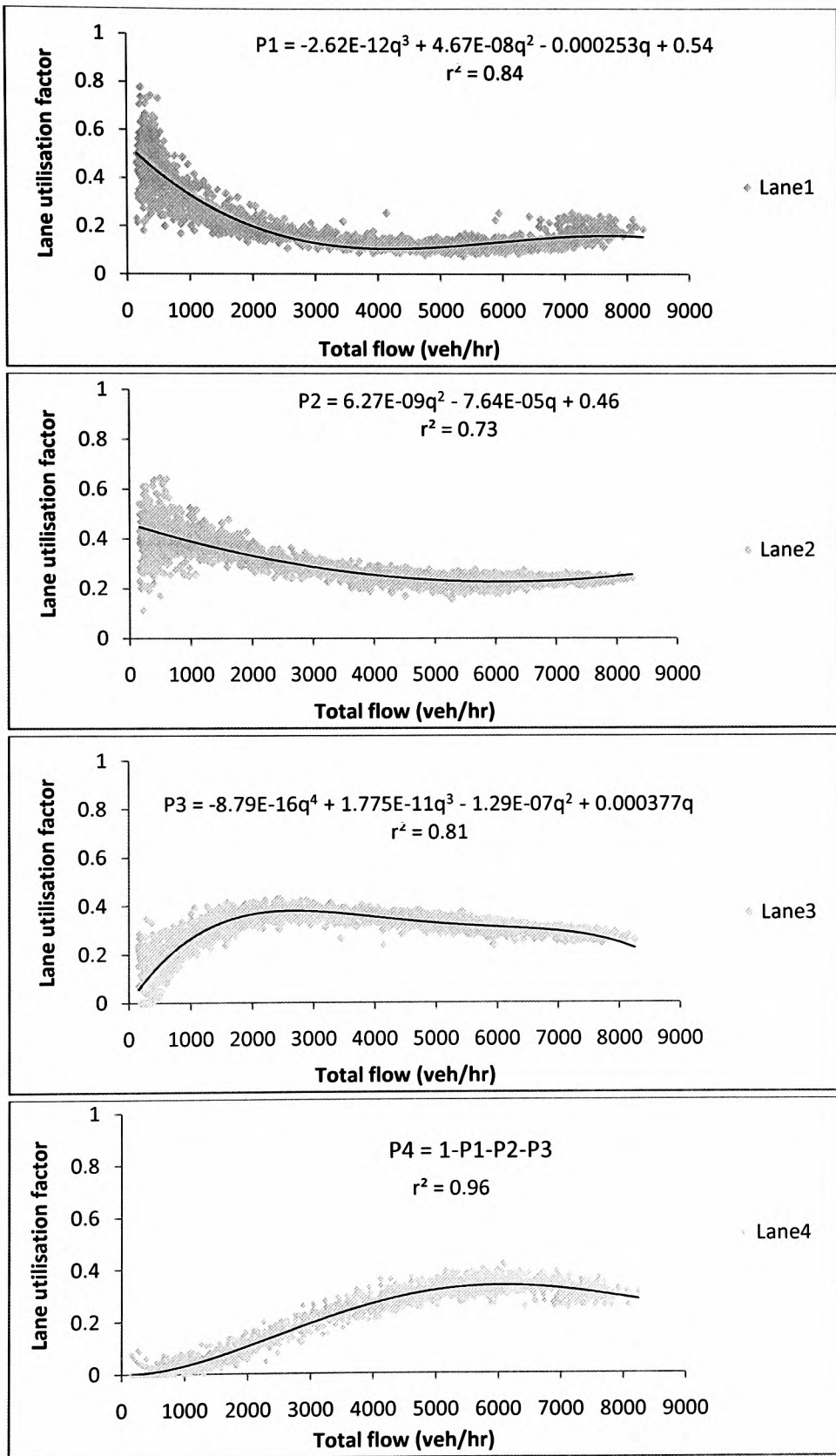

Figure 4-12 Lane utilisation for the M25 motorway (four lanes)

### 4.5.3. Lane utilisation for motorway traffic at merge sections

This section compares the lane distribution in sections further upstream (U2), just upstream (U1) and just downstream (D1) of the M56 J2 merge section (see Figure 4-13). To ignore the effect of scatter in the relationship of lane utilisation with flow rates, it was decided to use average values of lane utilisation coefficients for each flow rate within  $\pm 50$  veh/hr. According to this procedure, for example, the lane utilisation coefficient corresponding to a 2000 veh/hr flow rate represents the average lane utilisation factors for flow rates between 1950 and 2050 veh/hr. Figure 4-14 shows the results for location U1 and suggests same pattern to that presented earlier on the M602 motorway section.

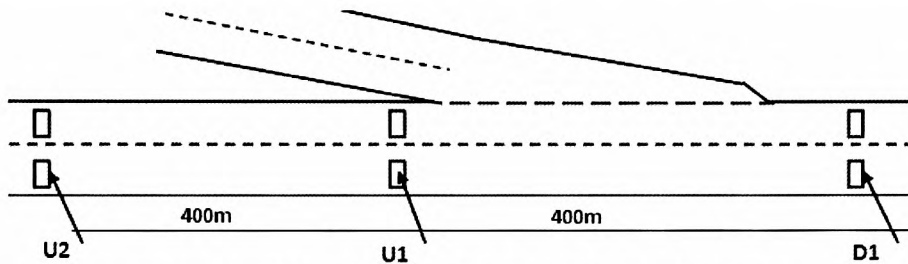

Figure 4-13 Detectors' locations for the M56 J2

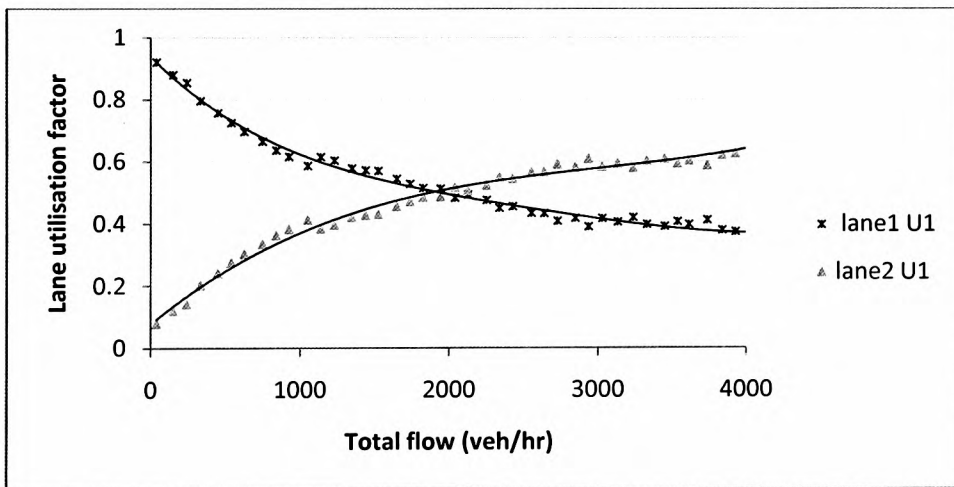

Figure 4-14 Average lane utilisation for location U1

Figure 4-15 shows a comparison between the lane utilisation factors in lane 1 for locations further upstream (U2) and just upstream (U1) of the M56 J2 merge section. The figure shows that the concentration of traffic in lane 1 in section U2 is higher than that in the U1 location at flow rates higher than 1000 veh/hr. This provides evidence on the tendency of drivers to avoid merging traffic by shifting (yielding) toward other lanes supporting the findings by Knoop *et al.* (2010). For lower flow rates, it seems that there is no need to undertake such yielding behaviour because of the availability of sufficient gaps that enables merging to take place without affecting motorway traffic.

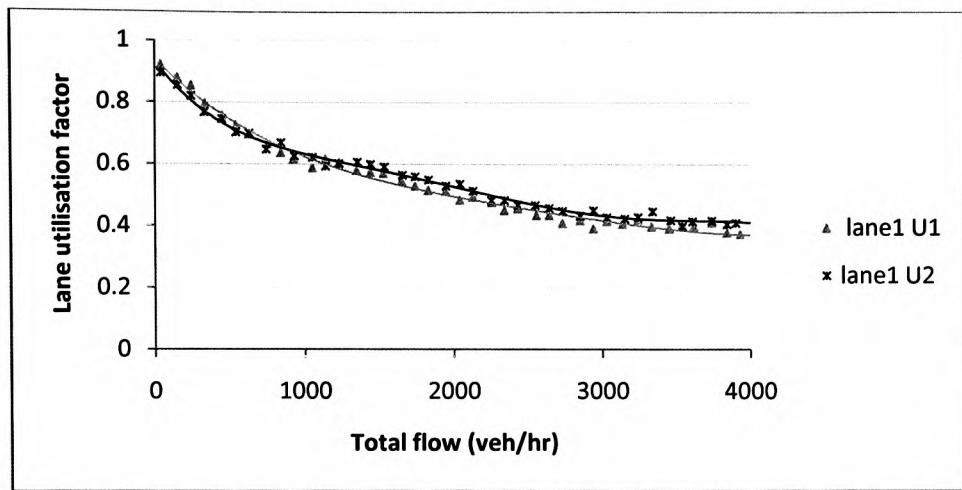

Figure 4-15 Average lane utilisation in lane 1 for locations U1 and U2

Figure 4-16 shows the lane utilisation factors for location D1 which is just downstream of the merge section (about 150m after the EOAL). The figure suggests that the flow rates in lanes 1 and 2 become equal when the total flow rate exceeds 3000 veh/hr. This is higher than a value of about 2000 veh/hr found in normal sections because the merge traffic may not directly change to the offside lane (i.e. lane 2) after merging into lane 1.

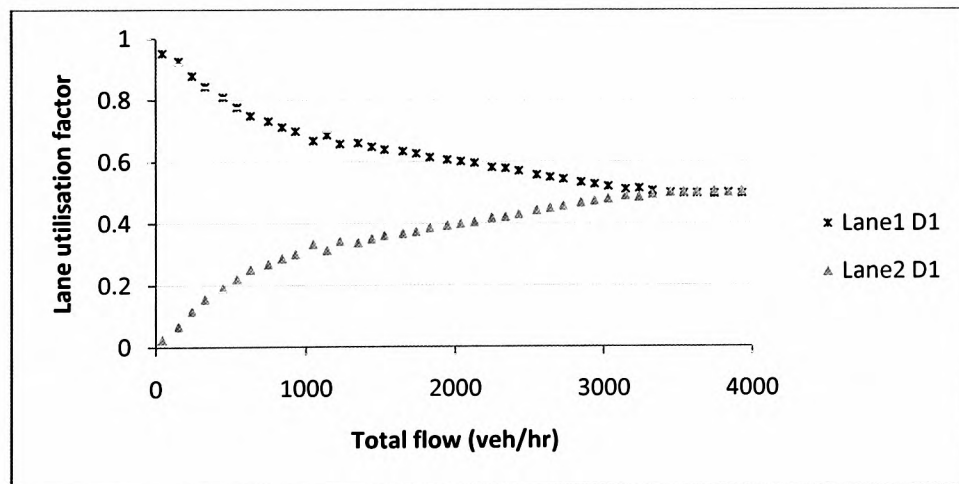

Figure 4-16 Average lane utilisation for location D1

The results shown in Figure 4-16 may also provide some evidence that drivers' behaviour is being affected by the presence of the merge section (such as drivers becoming more alert). This results in maintaining "close following" behaviour for a period of time (or distance) which is referred to as the relaxation period of about 20 seconds (see Laval and Leclercq, 2008) or about 450m from the start of the merge section as suggested by HCM (2010). This is an important finding which is incorporated in the development of the simulation model (see section 5.9.2.3).



### 4.5.4. Lane utilisation of slip road (merge) traffic

Data obtained from video cameras and loop detectors have been used in studying the lane utilisation for ramp sections. Two sections are considered as shown in Figure 4-17. These are position 1 which is before the merge section and position 2 which is at the nose where the auxiliary lane has started. The second location is chosen because observations for merge traffic on the M56 J2 suggest some differences in lane utilisation in this location between the cases when RM is on (RM-ON) and RM is off (RM-OFF).

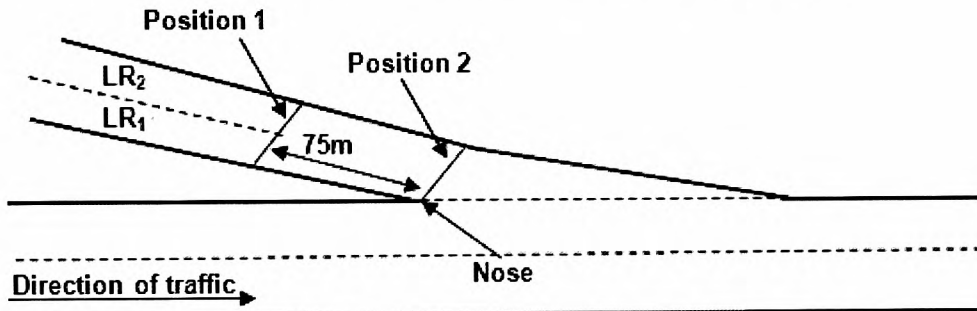

Figure 4-17 The M56 J2 section showing positions 1 and 2

#### 4.5.4.1. Lane utilisation before the merge section (Position 1)

As shown in Figure 4-17, the ramp in the M56 J2 consists of two lanes ramp section which merges into the motorway using one acceleration lane. The junction is served by a RM device to alleviate traffic congestion propagated from the station of merging the M56 with the M60 motorways (Highways Agency, 2008).

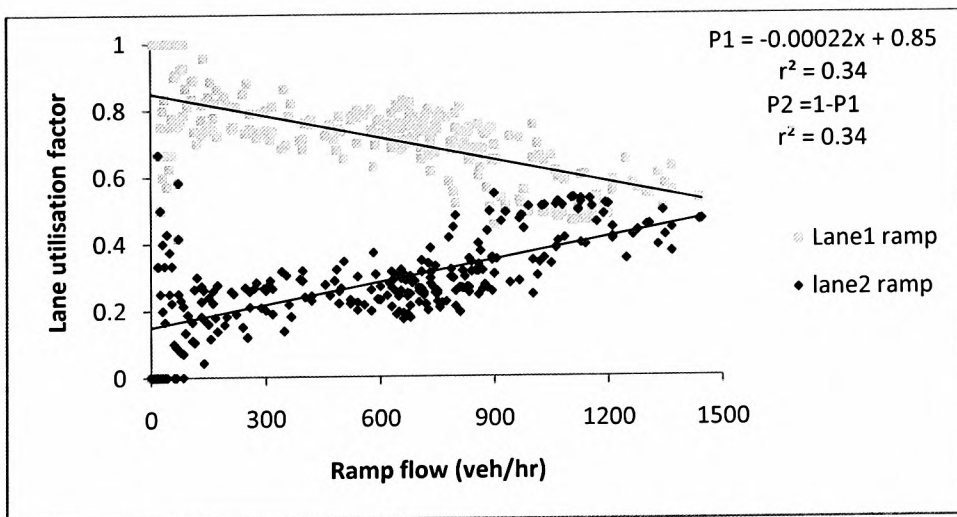

Figure 4-18 Lane utilisation for a 2-lane on-ramp (M56 J2) at Position 1

Data taken from loop detectors located at position 1 as shown in Figure 4-17 have been used to estimate the lane utilisation factor. The results are presented in Figure 4-18. While the results have similar shapes to that obtained for lane utilisation on the M602 motorway

with a 2-lane section, the developed regression equations suggest lower  $r^2$  values than those found on normal motorway sections. However, the results show that the two lanes of the ramp section would carry similar flow rates at around 1500 veh/hr total ramp flow rate.

#### 4.5.4.2. Lane utilisation at the start of merge section (Position 2)

Because no loop detectors were installed on the nose section (Position 2 in Figure 4-17), video recordings data has been used in studying lane utilisation at this section. The data were recorded from the M56 J2 site for two mornings and one evening peak periods covering some periods when the RM signal was on and off. The data were aggregated for every 5 minute interval and separated based on the operation status of RM (i.e. RM-ON and RM-OFF). In the cases with RM-OFF as shown in Figure 4-19, most traffic utilised the first lane of the slip road (i.e. LR1 in Figure 4-17). This is because that the drivers on the second lane of the slip road (LR2) merge with the first lane traffic once they approach the merge section. In the cases of RM-ON, Figure 4-19 shows that vehicles enter the acceleration lane utilising both ramp's lanes. This could be explained by the fact that drivers may not get enough gaps to change to the first lane within the short distance (75m) between the traffic signals' stop line and the nose.

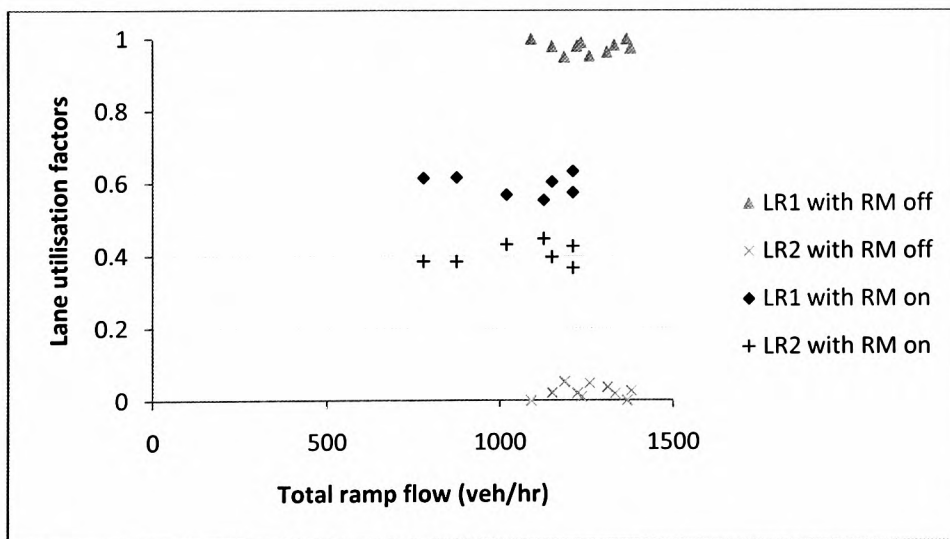

Figure 4-19 Lane utilisation for a 2-lane on-ramp on the nose section for the M56 J2

#### 4.5.5. Lane utilisation of heavy goods vehicles

For HGVs' lane utilisation, individual vehicles' raw data for a full 14 days from both the M25 and the M42 motorway sites were used. The data combined all the vehicles in all lanes and in both directions. Equivalent hourly traffic and HGVs' flows were estimated for every 10 minutes interval, and 5 minutes intervals were also tested. Using higher interval periods such as 1 hour, as adopted by Hollis and Evans (1976), was not considered

as it might combine different flow conditions ranging between free and congested situations. Since vehicles' types were not clearly defined in the data and only the lengths of vehicles were obtained, a similar approach to that used by the Highways Agency to define HGVs, was considered in this work. Therefore, a value of 6.6m was used as a threshold value for the length of vehicles between HGVs and non-HGVs vehicles. The process of estimating flow rates and defining vehicle types were undertaken using a simple computer program using Compaq Visual FORTRAN-2005 (see Program1 in Appendix B).

#### 4.5.5.1. Testing of previous HGVs' lane utilisation models

Some of the developed models for HGVs' lane utilisation in previous research have been tested using data from the M42 and M25 motorway sites. The details of these models and the test results (i.e. the coefficient of determination values,  $r^2$ ) are shown in Table 4-10. The table suggests that these models need to be refined in order to get better representation of the real data (especially that some of these previous models are based on old data taken in past two to three decades) and therefore some  $r^2$  values are very low.

Table 4-10 Testing previous models of HGVs' lane utilisation using data from the M42 (3-lane motorway) and M25 (4-lane motorway)

Reference	Lane	HGVs' lane utilisation model	$r^2$	
			M42	M25
Hollis and Evans (1976)	1	$P1=1200/(1200+q_h)$	0.59	0.57
	2	$P2= q_h / (1200+ q_h)$	0.55	0.38
Turner (1983) taking the effect of HGVs flow	1	$P1=( q_h +129.76)/(2.17 q_h)$	0.21	0.27
	2	$P2=( q_h -139.49)/(1.73 q_h)$	0.20	0.27
Turner (1983) taking the effect of total flow	1	$P1=(174.44-15.57 \ln q)/ q_h$	0.53	0.52
	2	$P2=1-P1$	0.50	0.32
Fwa and Li (1995) taking the effect of HGVs flow	1	$P1=(45.1+0.608 q_h +0.000308 q_h^2)/ q_h$	0.09	0.05
	2	$P2=1-P1$	0.09	0.04
Fwa and Li (1995) taking the effect of total flow	1	$P1=(174.4+0.082q-0.0000125q^2)/ q_h$	0.21	0.35
	2	$P2=1-P1$	0.20	0.23

Figure 4-20 compares the lane utilisation coefficients obtained from the M42 motorway data with the models by Hollis and Evans (1976) and Turner (1983) with respect to HGVs' flow. The figure together with Table 4-10 shows that the Evans and Hollis' models give better representation of the current data, as compared with those models developed by Turner (1983). The effect of total motorway flow on lane utilisation factors based on the

M42 motorway data is presented in Figure 4-21. The figure shows that the concentration of HGVs in lane 2 increases with an increase in traffic flow. The models by Turner (1983), as shown in Figure 4-21, suggested that lanes 1 and 2 will have the same proportion of HGVs when the motorway flow reaches a value of about 3000 veh/hr; after that, lane 2 will start to carry more of the proportion of HGVs. In fact, the real data presented in Figure 4-21 suggested that the proportion of HGVs in lane 1 is always higher than those in lane 2 even at higher flow rates approaching motorway capacity.

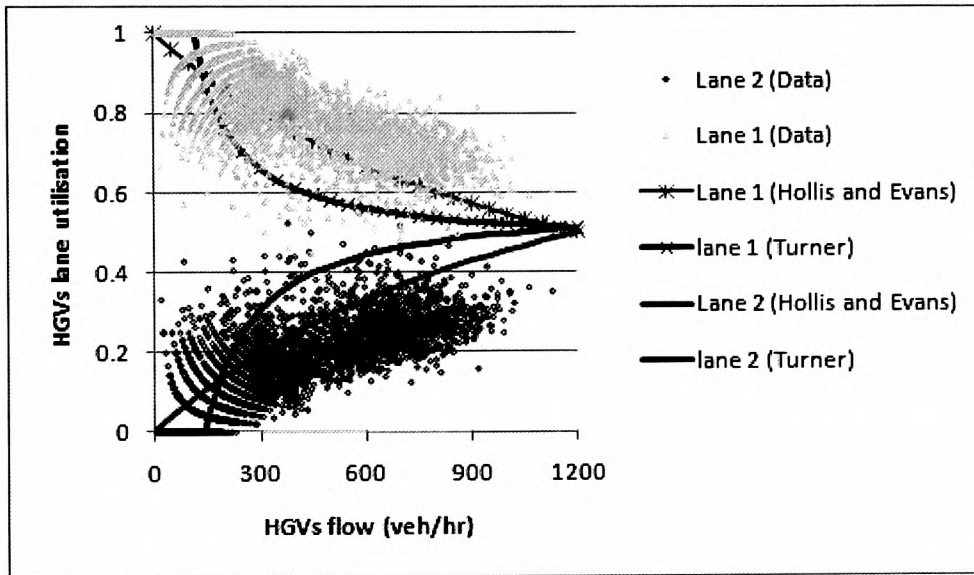

Figure 4-20 HGVs' lane utilisation for the M42 with respect to HGVs' flow ( $q_h$ ) compared with the Hollis and Evans (1976) and the Turner (1983) models

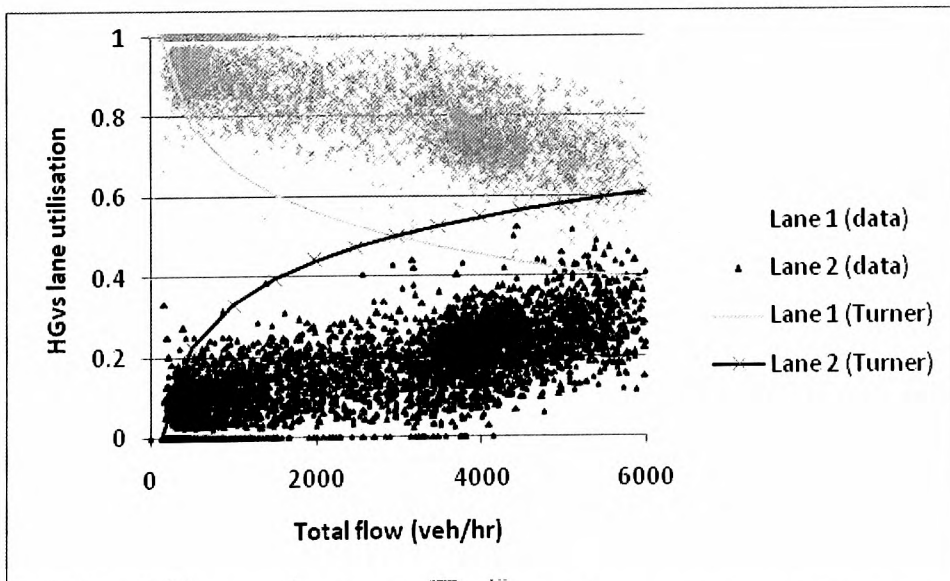

Figure 4-21 HGVs' lane utilisation for the M42 with respect to total flow ( $q$ ) compared with the Turner (1983) model

#### 4.5.5.2. Development of new models

Based on the discussion in the previous section, some of the previous HGVs lane utilisation models were based on old data. The reliance on the Motorway Incident Detection and Automated Signalling (MIDAS) data which is widely used in the UK will not help in estimating the proportions of HGVs in each lane, since this data source (i.e. MIDAS data) does not specify the percentage (or number) of HGVs by lanes. Therefore, there is a need to develop new models for HGVs' lane utilisation in order to provide more realistic applications for this sort of data (i.e. MIDAS data) in micro-simulation traffic models which are widely used to assess and evaluate solutions to current traffic problems. These HGVs lane utilisation models are also useful in the assessment of commercial vehicles (HGVs) using lanes when it comes to pavement design.

The new models have been developed based on simple linear regression analysis using SPSS software. Factors which are considered in this study are HGVs' flow ( $q_h$ ), total flow ( $q$ ) and average speed ( $V$ ). Although traffic density (or traffic occupancy) may affect the instantaneous use of lanes, the effect of traffic density is presented through taking the effects of traffic flow and speed parameters. It should be noted that the ranges of  $q_h$  for the data used are (0 to 1200) and (0 to 1500) veh/hr for the M42 and the M25 motorways, respectively.

The results from the regression analysis with respect to the selected parameters (i.e.  $q$ ,  $q_h$  and  $V$ ) are shown in Table 4-11 for both the M42 and M25 motorway sites.

In general, and by considering the effect of each selected parameter separately using a stepwise regression analysis, the results suggest that total flow ( $q$ ) is the most important factor in modelling HGVs' lane utilisation. In addition, using the HGVs' flow ( $q_h$ ) only as a parameter gave better  $r^2$  values than using the average speed ( $V$ ). Combining the effect of  $q$  and  $q_h$  parameters would significantly enhance the  $r^2$  values. Moreover, the effect of these three parameters (all together) also makes the  $r^2$  values more reliable especially in the case of the M25 motorway.

For practical reasons and since speed data might not always be available, the developed models, considering the combined effects of  $q$  and  $q_h$ , are recommended for use (see the embolded models in Table 4-11).

It should be noted that these new developed models are based on average 10 minutes' intervals of data. Using data from lower time intervals such as 5 minutes have also been tested and have given lower reliable models (due to higher scatter in the data).

Table 4-11 Regression models for HGVs' lane utilisation using data from the M42 (3-lane motorway) and M25 (4-lane motorway)

Motorway	Lane	Model parameters used	r <sup>2</sup>	Remarks
Model 1 (HGVs flow only)				
M42	1	$P_{H1}=0.949 - 0.00034225q_h$	0.58	Simple models which could be used (3 lanes)
	2	$P_{H2}=1 - P_{H1}$	0.52	
M25	1	$P_{H1}=0.878-0.00083q_h+3.87E-7q_h^2$	0.54	Ignore (low r <sup>2</sup> values)
	2	$P_{H2}=0.138+0.00049q_h-2.489E-7q_h^2$	0.39	
	3	$P_{H3}=1 - P_{H1} - P_{H2}$	0.48	
Model 2 (Total flow only)				
M42	1	$P_{H1}=0.951 - 0.000047q$	0.58	Simple models which could be used (for 3 and 4 lanes)
	2	$P_{H2}=1 - P_{H1}$	0.52	
M25	1	$P_{H1}=0.841 - 0.00005694q$	0.60	
	2	$P_{H2}=0.165 + 0.00003102q$	0.42	
	3	$P_{H3}=1 - P_{H1} - P_{H2}$	0.45	
Model 3 (speed only)				
M42	1	$P_{H1}=0.0439 + 0.004V$	0.16	Ignore (low r <sup>2</sup> values)
	2	$P_{H2}=0.558 - 0.004V$	0.16	
M25	1	$P_{H1}=-0.005 + 0.00606V$	0.42	
	2	$P_{H2}=0.624 - 0.00328V$	0.29	
	3	$P_{H3}=1 - P_{H1} - P_{H2}$	0.34	
Model 4 (HGVs flow and total flow)				
M42	1	<b><math>P_{H1}=0.976 - 0.0002044q_h - 0.0000285q</math></b>	0.70	Recommended models to be used (for 3 and 4 lanes)
	2	<b><math>P_{H2}=1 - P_{H1}</math></b>	0.63	
M25	1	<b><math>P_{H1}=0.862 - 0.0002007q_h - 0.00003943q</math></b>	0.67	
	2	<b><math>P_{H2}=0.154 + 0.00011q_h + 0.00002143q</math></b>	0.46	
	3	<b><math>P_{H3}=1 - P_{H1} - P_{H2}</math></b>	0.51	
Model 5 (HGVs flow, total flow and speed)				
M42	1	$P_{H1}=0.812 - 0.00019q_h - 0.00002722q + 0.0015V$	0.72	Recommended models to be used (for 3 and 4 lanes)
	2	$P_{H2}=1 - P_{H1}$	0.65	
M25	1	$P_{H1}=0.488 - 0.00017q_h - 0.0000303q + 0.00315V$	0.75	
	2	$P_{H2}=0.354 + 0.000096q_h + 0.0000165q - 0.0017V$	0.52	
	3	$P_{H3}=1 - P_{H1} - P_{H2}$	0.60	

## 4.6. Headway distribution

Several headway distribution models were proposed to describe the arrival of vehicles for a specific section. In general, these models could be classified into either simple or composite models. The simple models describe the arrival using single criteria while the composite models use two formulas, one for restrained vehicles and the other for free vehicles.

### 4.6.1. Simple headway models

#### a. *Negative exponential model*

This model is able to describe the arrival rates for free flow conditions using the following probability density function (p.d.f.) (Salter and Hounsell, 1996):

$$f(t) = e^{-qt} \quad \text{Equation 4-5}$$

where  $q$  is the flow rate (veh/sec) and  $t$  is the headway in seconds.

#### b. *The shifted negative exponential*

This shifts the negative exponential distribution by a minimum headway ( $c$ ). It is reported that this model is able to represent the arrival rate for free to moderated flow only. The probability density function for this model is as follows (Sultan, 2000);

$$f(t) = \frac{1}{\frac{1}{q}-c} e^{-[(t-c)/(\frac{1}{q}-c)]} \quad \text{Equation 4-6}$$

#### c. *Lognormal distribution*

The probability density function for this model is (Branston, 1976):

$$f(t) = \frac{1}{\sigma t \sqrt{2\pi}} e^{-\frac{(\ln(t)-u)}{2\sigma^2}} \quad \text{Equation 4-7}$$

$$u = \ln(m') - \sigma^2/2 \quad \text{Equation 4-8}$$

$$\sigma^2 = \ln\left(\frac{s'^2}{m'^2}\right) - 1 \quad \text{Equation 4-9}$$

where,

$m'$  and  $s'$  are the mean and the standard deviation of the lognormal distribution, respectively

$u$  and  $\sigma$  are the mean and the standard deviation of the normal distribution, respectively.

The  $m$  and  $s$  values were recommended to be independent of the flow rate with the following values (Branston, 1976):

$$\begin{array}{lll} m' = 1.6 \text{ sec} & s' = 0.4 \text{ sec} & \text{for slow lane} \\ m' = 1.3 \text{ sec} & s' = 0.4 \text{ sec} & \text{for faster lane} \end{array}$$

According to Tolle (1976) the model is able to describe the headway for high flow rates.

#### 4.6.2. Composite headway models

These types of models apply two different formulas to determine the headways of free and following (restrained) vehicles. The probability density function in these types of models takes the following form (Branston, 1976):

$$f(t) = \phi g(t) + (1 - \phi)h(t) \quad \text{Equation 4-10}$$

where,

$\phi$  is the proportion of the following (restrained) vehicles,  
 $g(t)$  is the p.d.f of following vehicles, and  
 $h(t)$  is the p.d.f of the non-following vehicles.

##### a. Double exponential model

The p.d.f function for this model is represented by the following equation:

$$f(t) = \phi e^{-\frac{t-c}{T_1-c}} + (1 - \phi)e^{-\frac{t}{T_2}} \quad \text{Equation 4-11}$$

where,

$c$  is the minimum headway (sec).  
 $T_1$  is the average headway of restrained vehicles (sec), and  
 $T_2$  is the average headway of free vehicles (sec).

Salter (1989a) suggested that a value of 0.75 is reasonable for  $\phi$  under congested situations and a value of 2.5 seconds for  $T_2$ . The  $T_1$  value was suggested to be obtained from the following equation.

$$T_1 = \frac{T_2 \left( \frac{1}{q} - (1 - \phi) \right)}{\phi} \quad \text{Equation 4-12}$$

Also, Salter (1989b) suggested Equation 4-13 to be used in estimating the proportion of restrained vehicles ( $\phi$ ) for flow rates, "f" in veh/hr. between 660 and 1295 veh/hr/lane.

$$\phi = 0.00158f - 1.0422 \quad \text{Equation 4-13}$$



*b. Generalised queuing model*

According to this model, vehicles are travelling in random queues. The queuing model consists of two separate criteria for free vehicles and for restrained vehicles. The lognormal distribution was widely used in estimating the headways of restrained vehicles (see, for example, Skabardonis (1981), Yousif (1993), Sultan (2000) and Zheng (2003)). The headway of the free vehicle is estimated as the sum of constrained headway and headway derived from the negative exponential distribution.

The proportion of restrained vehicles is obtained from Equation 4-14 while the flow of free vehicles ( $q^*$ ) is obtained from Equation 4-15 as suggested by Branston (1976).

$$\emptyset = m'q - 0.5q^{0.5}(m'q - 1) \quad \text{Equation 4-14}$$

$$q^* = q - 0.5q^{1.5} \quad \text{Equation 4-15}$$

#### 4.6.3. Testing headway models using real data

Video recordings of data from the M62 motorway in addition to data from the M42 have been used in order to fit the data with the headway distribution models. The sections under study were far away from merge or diverge sections and consisted of three lanes carrying flow rates ranging from 800-2040 veh/hr/lane. For each site, data for 30 minutes period were used. The tested models are the shifted negative exponential, the double negative exponential and the generalised queuing model with lognormal distribution for restrained vehicles.

Using the shifted exponential distribution and based on the M42 data, Figure 4-22 shows good agreement between the actual and the predicted cumulative headway distribution for lanes 1 and 2 with flow rates of 1048 and 1750 veh/hr, respectively. For lane 3 with a flow rate of 2040 veh/hr, the results in Figure 4-23 reveal that this model is not applicable for such high flow rates. The best shift values (which gave better results) of 0.9, 0.6 and 0.3 were obtained for lanes 1, 2, and 3 respectively.

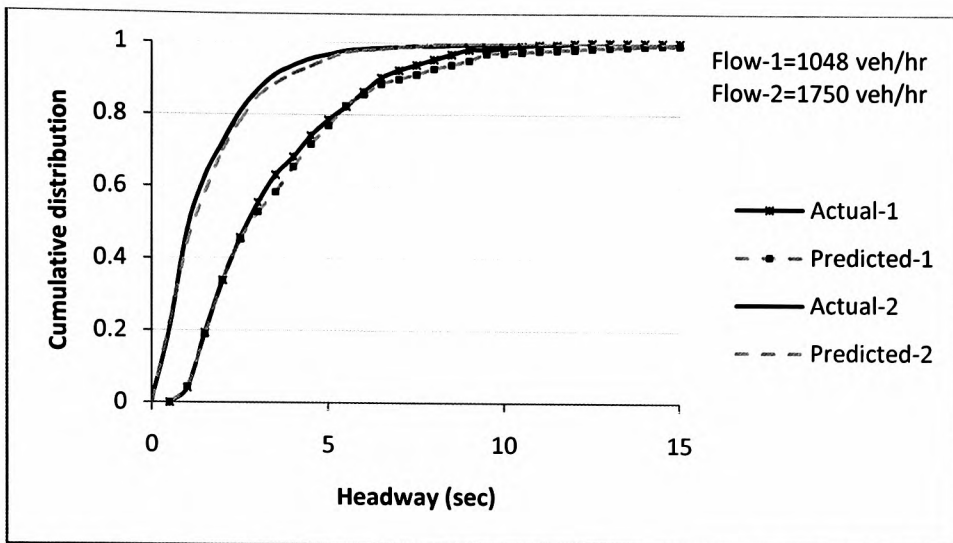

Figure 4-22 Actual and predicted cumulative distribution of headways in lanes 1 and 2 on the M42 using the shifted negative exponential distribution

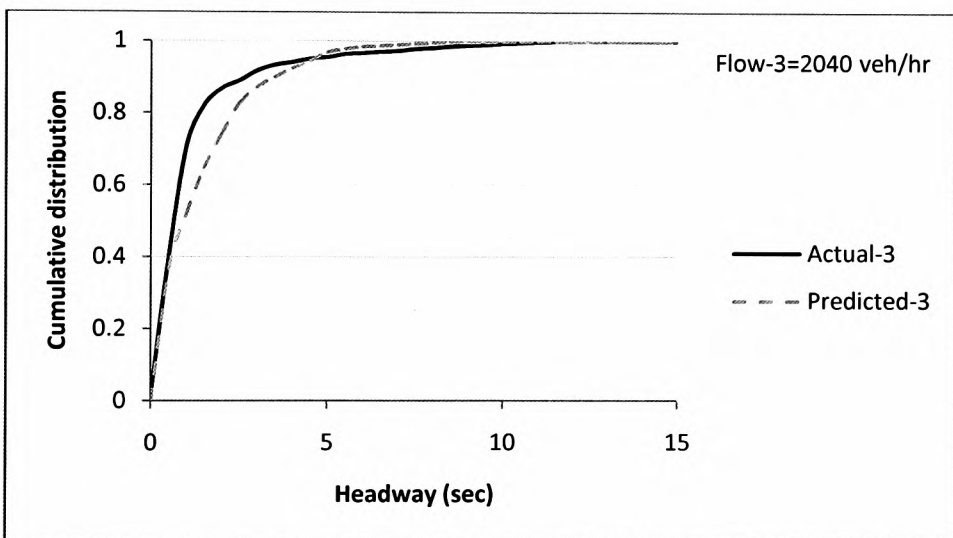

Figure 4-23 Actual and predicted cumulative distribution of headways in lane 3 of the M42 using the shifted negative exponential distribution

Also the results suggest that the generalised queuing model could only deal with the heavy flow rates on lane 3 as shown in Figure 4-24 and Figure 4-25 which are based on the M42 data. This was found to be consistent with other research (see for example Skabardonis (1981) and Zia (1992)) who recommended the use of this model for high flow rates only in any lane. The best mean headway parameters ( $m'$ ) that could be achieved for this distribution are 1.6, 1.3 and 1.1 seconds for lanes 1, 2 and 3 respectively. This is in agreement with the findings of Branston (1976) who suggested that values of 1.6 and 1.3 seconds are recommended for slow and high speed lanes respectively for motorways with two lanes.

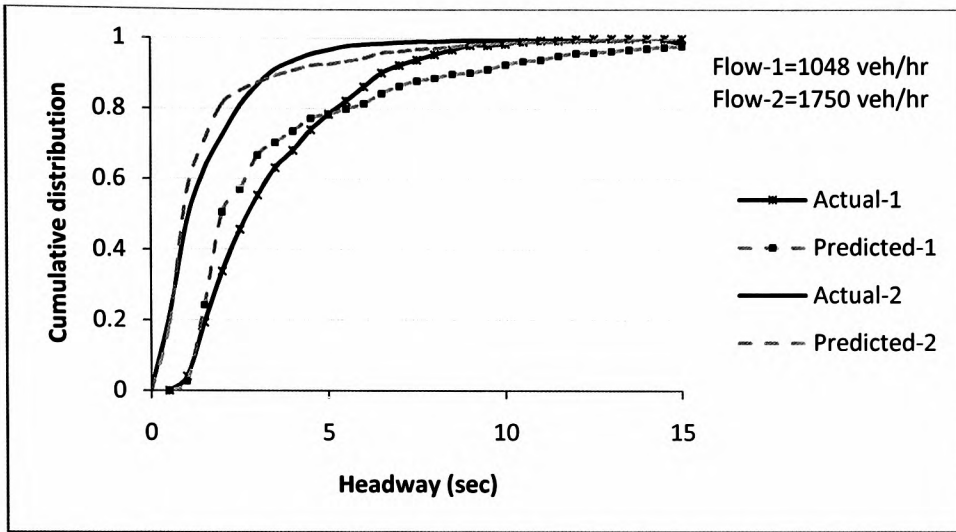

Figure 4-24 Actual and predicted cumulative distribution of headways in lanes 1 and 2 of the M42 using the generalised queuing model

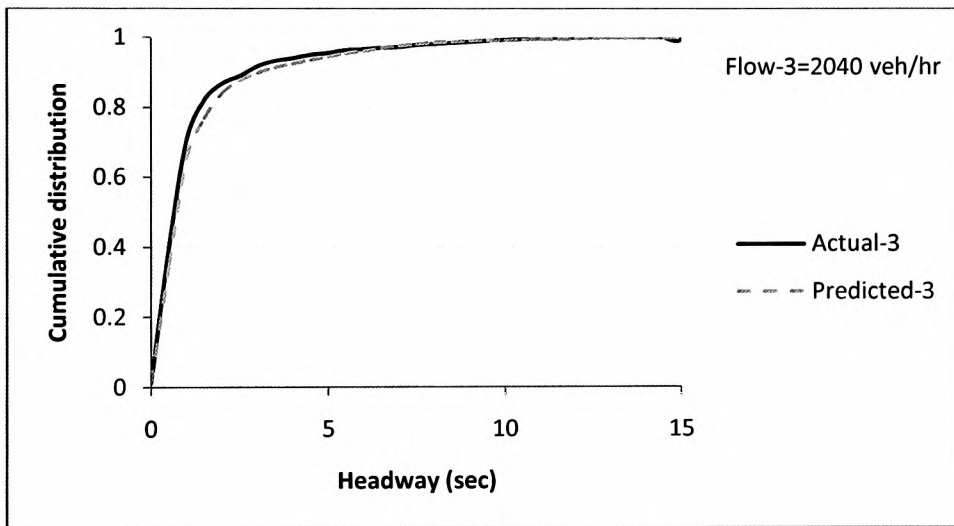

Figure 4-25 Actual and predicted cumulative distribution of headway in lane 3 on the M42 using the generalised queuing model

The results obtained from the double negative exponential distribution, as shown in Figure 4-26 and Figure 4-27, have a similar pattern to those presented for the shifted negative exponential distribution. The results suggest that the model could also represent the vehicles' arrivals for flow rates up to 1750 veh/hr/lane. Values of 2.5 seconds and 0.75 were respectively used for the average headway of free vehicles ( $T_2$ ) and for the proportion of restrained vehicles ( $\phi$ ). The only variable parameter that was used in the analysis was the minimum headway of the following vehicles ( $C$ ) and the results suggested that the values of 1.0, 0.75 and 0.5 seconds are suitable for this distribution for lanes 1, 2 and 3 respectively.

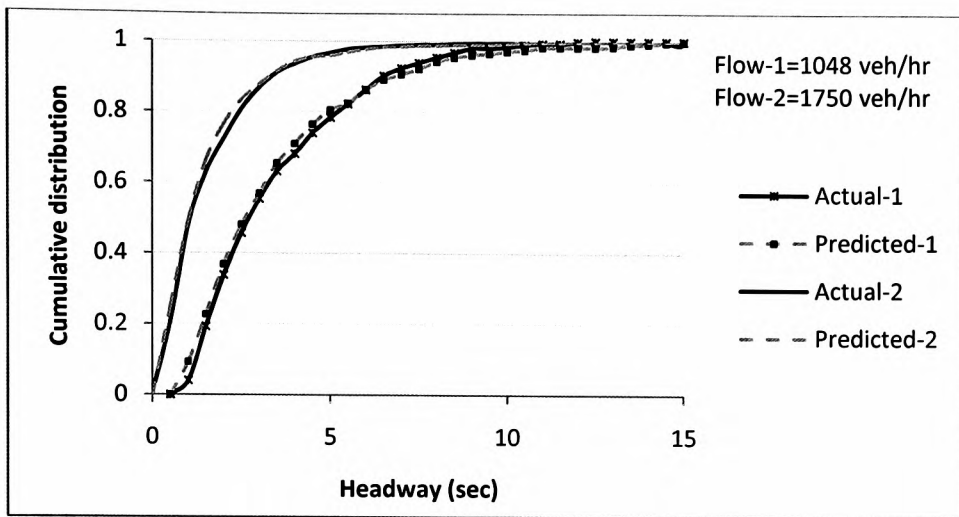

Figure 4-26 Actual and predicted cumulative distribution of headways in lanes 1 and 2 on the M42 using the double negative exponential model

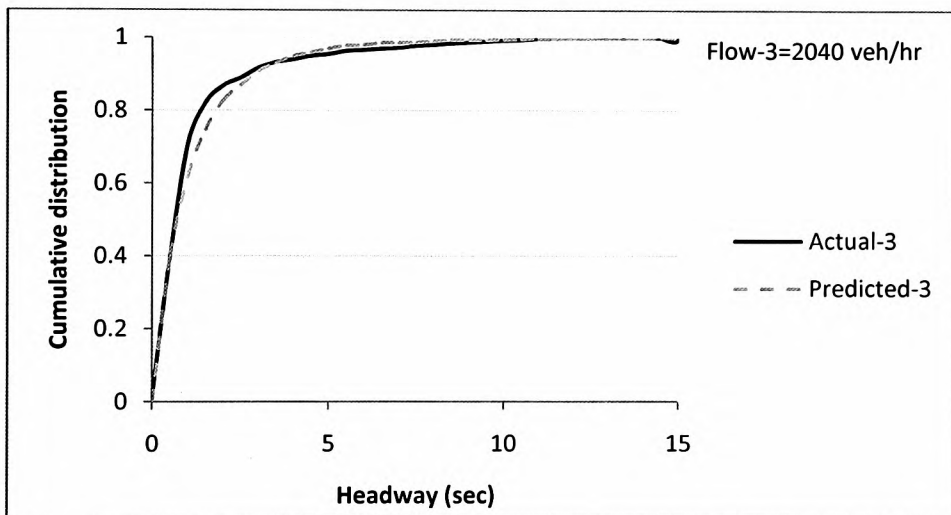

Figure 4-27 Actual and predicted cumulative distribution of headways in lane 3 on the M42 using the double negative exponential model

The results of the goodness of fit using the Kolmogorov-Smirnov (K-S) non parametric test for both the M42 and the M62 motorways are shown in Table 4-12 which could reflect the above explanations. In fact, the table suggests that not one of the tested models could represent the traffic arrivals for all ranges of tested flow rates. It should be noted here that the results on the validity of the type of headway distribution models (i.e. shifted/double exponential or generalised queuing models) conform with the findings of other studies for the observed levels of flow rates (see for example, Skabardonis (1981) and Zia (1992) and Yousif (1993)). However, there might be some underlying differences in drivers' behaviour or in the vehicles' length using the different lanes which may affect the validity of the mathematical headway models used to represent the arrival of vehicles at a section.

Table 4-12 Statistical results for testing goodness of fit for the headway distribution models using K-S test

Motorway		M42			M62		
Lane No.		1	2	3	1	2	3
Flow rate (veh/hr)		1048	1750	2040	880	1405	1607
K-S $D_{max}$	Shifted negative exponential	0.047	0.045	0.18*	0.028	0.06*	0.14*
	Double negative exponential	0.053	0.042	0.088*	0.072*	0.026	0.12*
	Generalised queuing model	0.167*	0.09*	0.052*	0.16*	0.07*	0.08*
$D_{cr}$		0.0594	0.046	0.0426	0.065	0.051	0.048

\* $D_{max} > D_{cr}$

### 4.7. Lane changing

#### 4.7.1. Frequency of lane changes (FLC)

It was reported that for locations far away from merge or diverge sections, the FLC is affected by total motorway traffic flow (Yousif, 1993 and Sultan and McDonald, 2001). The FLC was found to reach a maximum when motorway flow rates reach 1000-1300 veh/hr/lane. For higher flow rates, the FLC starts decreasing because there are insufficient gaps in other lanes or because there is no speed benefit from undertaking such lane changes.

However, the FLC are not similar for all sites even for similar flow rates. For example, see Figure 4-28 which shows the FLC for 3-lane motorway sections based on data by Yousif (1993) and McDonald *et al.* (1994).

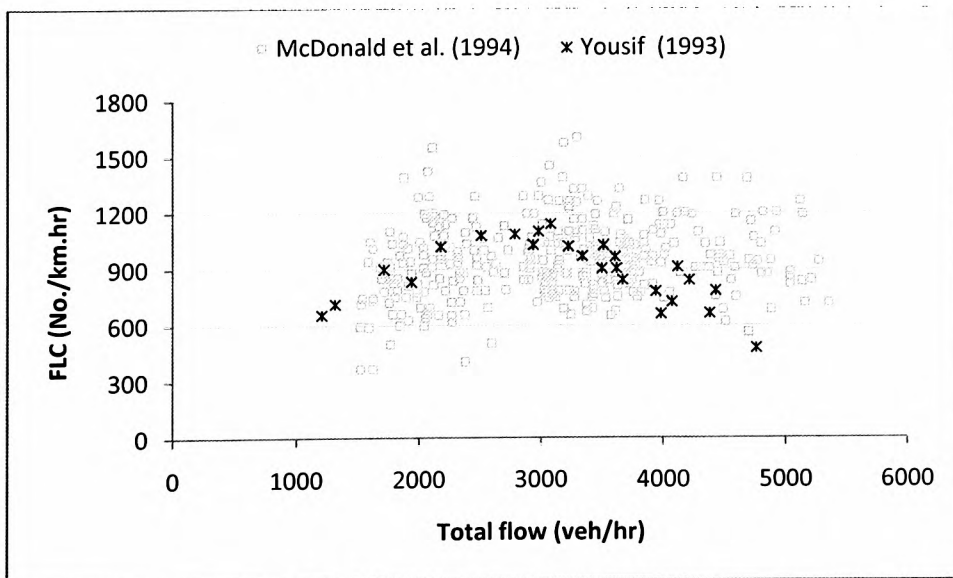

Figure 4-28 FLC for 3-lane motorway sections

Both of the latter two studies used the video recording technique when measuring the FLC on locations far away from merge or diverge sections. The former study is based on data

from the M4 motorway while the latter is based on data from the M27. In fact, Yousif (1993) reported some differences in the FLC based on data from 2-lane sections taken from the M4 and the A48.

In this study, the FLC is measured from the M602 section (urban motorway) with 2 lanes, the M60 J1-2 section with 3 lanes and the M60 J22-23 section with 4 lanes. The selected sections are far away from merge or diverge sections. For each site, video cameras placed on a bridge were used for collecting the data. The flow rates and the FLC data were extracted for every 5 minute interval similar to the interval length that was used by Yousif (1993). Sections of 200m length were covered for the M602 and the M60 J22-23 sites while only a 100m section was used for the M60 J1-2 due to existence of a gantry which obstructed the view.

For motorway sections with 2 lanes, Figure 4-29 shows the results for the M602 together with those reported by Yousif (1993) based on the M4. In general, both data suggested that the FLC reached a maximum at flow rate of 2000 veh/hr. However, the data from the M602, when compared with the M4 data, suggest higher FLC even at higher flow rates (between 3000 and 3500 veh/hr) and also show more scatters (see FLC at flow rate of 1500 veh/hr).

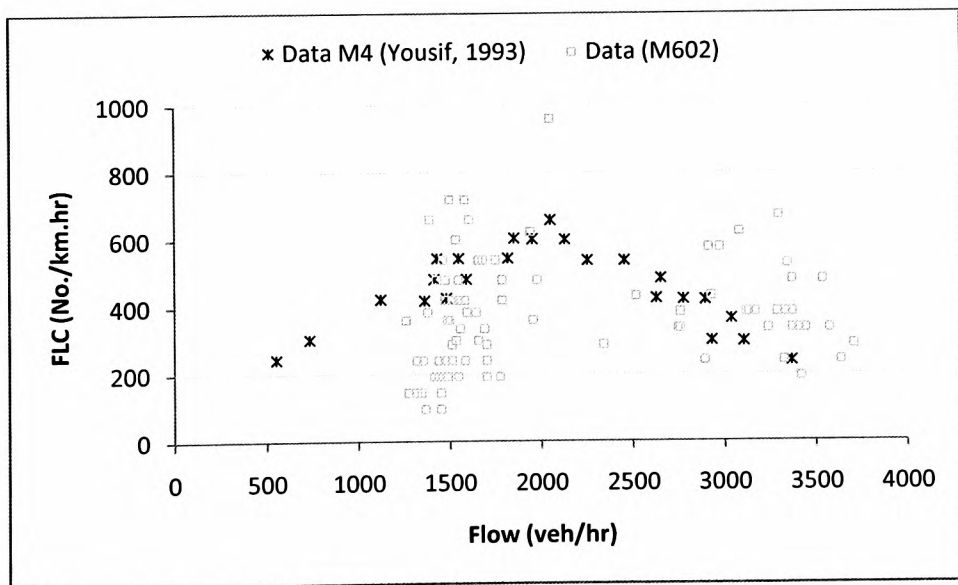

Figure 4-29 FLC for the M602 and the M4 with 2 lanes

For the M60 J1-2 motorway section with 3 lanes, the data only included high flow rates which are not covered by Yousif (1993) and McDonald *et al.* (1994) (i.e. higher than 5500 veh/hr). The equivalent hourly FLC was higher than 1000 LC/km with flow rates

varying between 5700 and 7000 veh/hr. However, it is believed that only viewing the short section of 100m may have influenced the results.

For the M60 J22-J23 motorway section with 4 lanes, the data available only covered flow rates less than 5000 veh/hr. The FLC results shown in Figure 4-30 suggests a linear increase in lane changes with an increase in the flow rates.

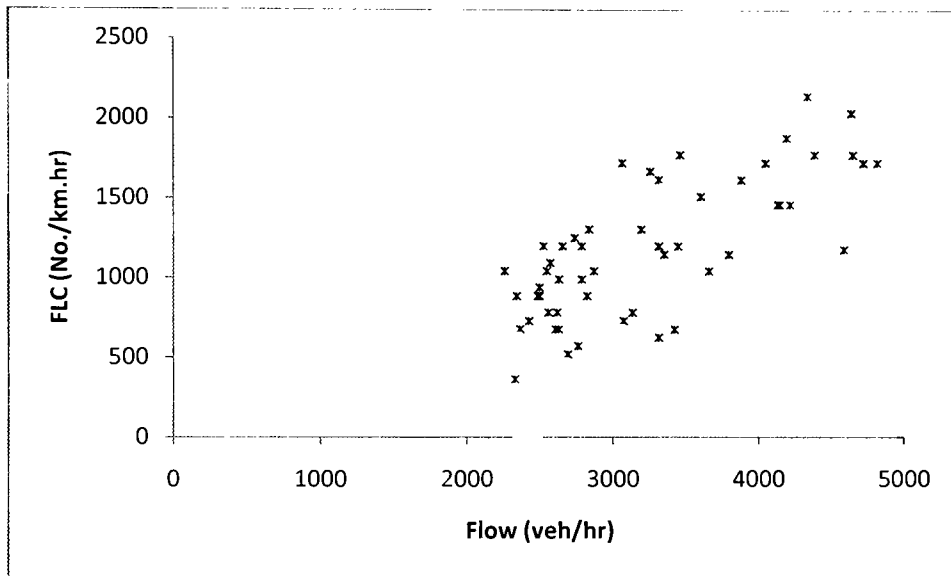

Figure 4-30 FLC for the M60 with 4 lanes

#### 4.7.2. Manoeuvring time for lane changing

Manoeuvring time for lane changing is the time required for a vehicle to execute its lane changing process from one lane to another. Yousif (1993) reported that this factor is measured from the instant that the vehicle starts its manoeuvring away from its lane until it settles in the new lane (i.e. becomes parallel to the initial lane). The average manoeuvring time and the standard deviation found by Yousif (1993) were 4.2 and 1.05 seconds respectively while Zia (1992) reported lower values of 3.0 seconds and 0.86 second.

In this study, and to test this parameter, video recordings taken from the M602 and the M6 were collected while travelling as a passenger and observing traffic from Manchester to Milton Keynes, UK on 31 March 2009. The manoeuvring time for lane changing is measured from the time a vehicle starts its manoeuvring until the rear wheels of the vehicle cross the marked line.

The results presented in Figure 4-31 confirm the finding by Yousif (1993) about the normality of the distribution of manoeuvring time ( $p=0.15$ ). The mean and standard deviation were 2.6 seconds and 0.57 second respectively. The results in the figure are for

passenger cars only. The average manoeuvring time and standard deviation for HGVs were 4.15 and 0.7 seconds respectively.

The manoeuvring time for merging traffic was also studied based on data from the M4 motorway and the results showed a lower value of 1.9 seconds for average manoeuvring time with an observed standard deviation of 0.6 second.

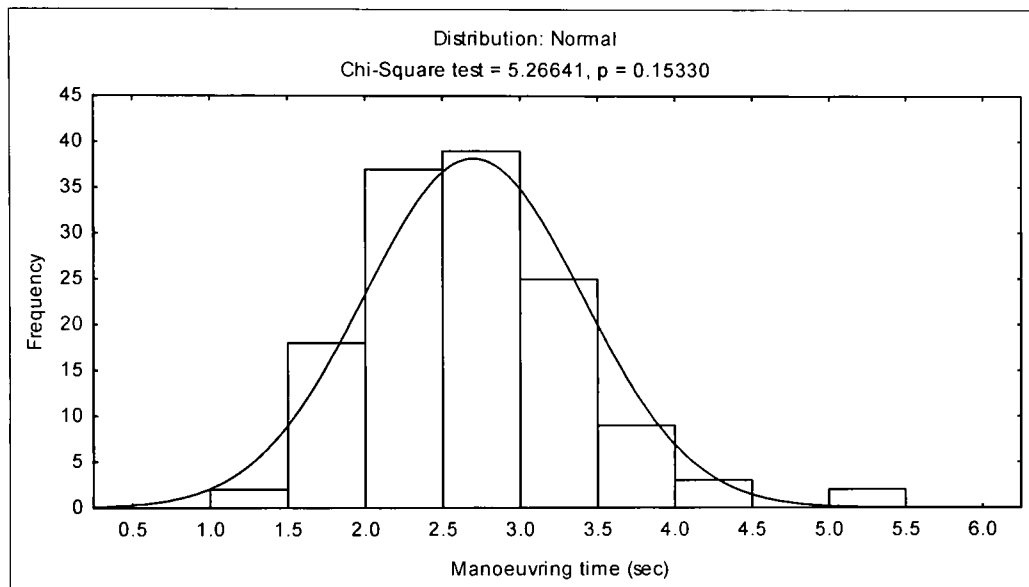

Figure 4-31 Distribution of manoeuvring time for lane changing

## 4.8. Merging behaviour

### 4.8.1. Merging position

Video recorded data from the M60 J10 site with moderate flow rates (between 4500 and 5000 veh/hr) were used in estimating the merging position where vehicles start their manoeuvring towards the motorway lanes. The junction consists of 2 lanes on ramp merging with a 3-lane motorway section. The length of the auxiliary lane is about 185m. The positions of the vehicles were measured with a distance interval of 18m which is equivalent to the distance between two midlines in the lane markings. Data from 416 merging cases were used and the results are shown in Figure 4-32. The figure suggests that 85% of drivers merge within the first 50m of the acceleration lanes. This is consistent with Zheng (2003) who reported that more than 80% of drivers start merging within the first 50m of the acceleration lane based on data from the M27 in the UK. The results are also similar to those obtained by Kou and Machemehl (1997b) based on data from the USA.



While the results in Figure 4-32 reveal that no merging cases happened before reaching the start of the auxiliary lane, Zia (1992) reported that such cases of earlier merging exceeded 25% based on data from UK motorway sites. Therefore, this has been investigated further using video recordings from different sites. About 2500 merge cases were used to represent the results shown in Table 4-13 which suggests that no filmed merging cases were observed before reaching the auxiliary lane, even in congested traffic.

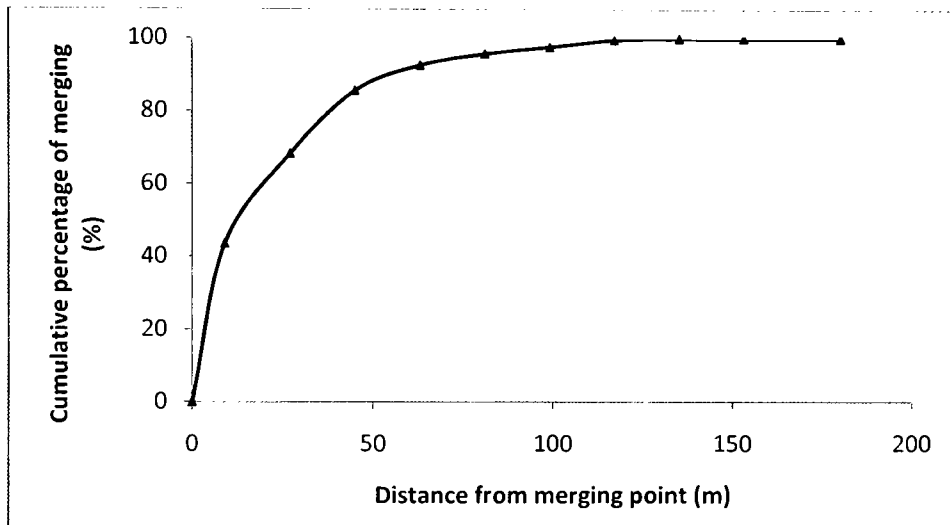

Figure 4-32 Cumulative distribution for merging position based on data from the M60 J10

Table 4-13 Traffic that merge before and after the nose length

Site	Before the nose (No.)	After the nose (No.)	Before the nose (%)	Duration (minutes)
M56 J2	0	994	0	47
M60 J3	1	137	0.7	10
M60 J2	0	272	0	32
M60 J23	5	227	2.2	15
(M60-M602) J12 congested traffic	0	848	0	50

#### 4.8.2. Gap selection behaviour

Merging vehicles start searching for sufficient gaps to merge once they approach the visible section of the motorway merge section (Zheng, 2003). When the current gap is not large enough to merge into, the driver may select another gap (either the next or previous gap as illustrated in Figure 4-33). However, drivers may wait to get either cooperative or yielding behaviour from the lag vehicle (J2) on the inside lane of the motorway. These two latter actions (as will be defined and explained next in this chapter) cause an increase in the lag gap and thus increases the chances of accepting the original gap. About 3000 merge cases were observed at different merge sections and are used in this study to show

the percentage of drivers who accept the first (original) gap. The results suggest that most drivers accept the first gap. This behaviour has been observed for different levels of flow including the cases of free following and very congested situations. The data from the M6 J10 with moderate flow rates suggested that 98.8% of drivers accepted the first gap and 1.2% selected the next gap. For the M60 J12 with very congested traffic, 99.6% of drivers accepted the first gap while only 0.4% accepted the next and the previous gaps. At free flow conditions, data from the M60 J23 reveals that all drivers accepted the original gap due to an increase in size of the available gaps. The results are also consistent with those of Zheng (2003) and Kou and Machemehl (1997a) who reported that drivers seldom reject the first gap.

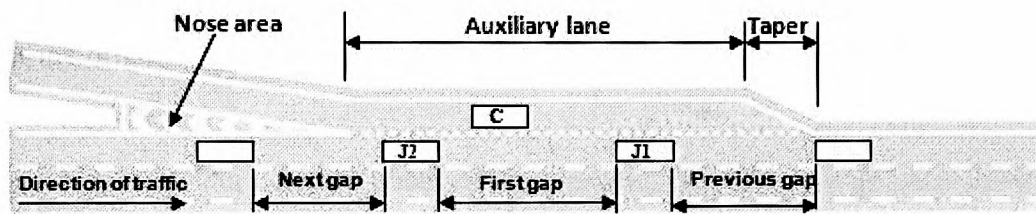

Figure 4-33 Illustration of the first, next and previous gaps in merging behaviour

#### 4.8.3. Merge ratio

“Merge ratio” is a term commonly used in describing the priority of movements between merge and motorway traffic on the inside lane (shoulder lane) when both the upstream motorway and the merge traffic are congested (Bar-Gera and Ahn, 2010). However, the same term was also used by Hounsell and McDonald (1992) to represent the ratio of merge to motorway traffic. In this section, the former definition for “merge ratio” is used (i.e. describing the priority of movements).

Cassidy and Ahn (2005) studied the merge ratio using data taken from four sites in the USA and reported one-by-one priority between motorway lane 1 and the merge traffic. Bar-Gera and Ahn (2010) examined the merge ratio using data taken from loop detectors and also found one-by-one priority in most cases. Troutbeck (2002) concluded that the reasons explaining one-by-one priority are due to a reduction in the risk associated with the merge because of the reduction of the motorway speed and also due to the creation of a uniform headway because of the queues in the two streams.

In this study, video recordings from the M60 J12 in the afternoon peak period on 17-3-2010 were used in studying the merge ratio. The traffic condition was similar to that stated by Bar-Gera and Ahn (2010) (i.e. queues were observed on both the motorway upstream section and the slip road). A similar priority to that found by Cassidy and Ahn (2005) and

Bar-Gera and Ahn (2010) was observed from the data when only 0.2% (2 out of 848 merging cases) of motorway drivers refused to give a priority to merge traffic. In fact, the observations showed some motorway drivers allow for more than one vehicle to merge in front of them.

#### **4.8.4. Cooperative and yielding behaviour**

In this work, cooperative behaviour refers to the decelerating of lag drivers on a motorway shoulder lane in order to increase the size of lag gaps provided for merge traffic. The yielding behaviour represents the cases where drivers prefer to shift to offside lanes when approaching merge sections. These two behaviours seem to be predominant for UK drivers and/or might be so in other parts of the world. The tendency of merging traffic to accept the original (first) gap by the majority of drivers may be due to such behaviour by motorway drivers.

The yielding behaviour could be obtained by measuring the number of lane changing cases upstream of the merge section by using video recordings. However, the number of cooperative cases could not be accurately measured without using trajectory data for the speeds and positions of vehicles. Unfortunately, these trajectory data are difficult to obtain without installing video recording camera(s) on relatively high buildings to film traffic.

In this study, cooperative cases are only selected when the lag vehicles flash their headlights to assist the merge traffic. This is a common phenomenon for UK drivers which indicate that they allow priority to others. Also, non-cooperative cases were obtained from the cases where the lag drivers did not allow others on the ramp section to merge in front of them. Based on data from the M60 J10 with normal traffic condition (i.e. not congested) and during 80 minutes' period, there were 40 cooperative and only 5 non-cooperative cases. In fact, there might have been many other cooperative cases which happened without flashing the headlights, but these cases were not considered.

The analysis of such cooperative cases reveals that drivers cooperate even when there are very small separations (0.2 second or less) between their vehicles and the merging traffic. On the other hand, the non-cooperative cases mainly occurred when the lag gap is less than zero.

For yielding behaviour, 62 cases were observed regarding encompassing very short lag gaps (sometimes negative when the merger vehicle on the auxiliary lane and the "lag vehicle" on the motorway are overlapping) or were related to a high speed difference

between the merge traffic and motorway traffic. It should be noted that 30% of the yielding cases started at a distance of about 100m upstream of the merging point. Most of the other cases start at a distance between 50 and 100m. No attention has been given for finding the distribution of the starting distance for yielding behaviour due to visual issues associated with the video recordings.

#### 4.8.5. Size of accepted gaps

As mentioned in the above sections, ramp drivers usually accept the first gap even for high flow rates and congested traffic situations. This fact will cause the observed mean times for the accepted lead and lag gaps to be changeable with the level of traffic flow. Consequently, this may reduce the reliability of using a specific time threshold as a mean value for gap acceptance behaviour. For example, Zia (1992), based on data from four motorway sites within the UK, found that the average lead gap varied from 1.7 to 2.55 seconds and the average for the lag gap was found to be vary from 2 to 3 seconds. Zheng (2003) found that the average lead and lag gap for certain flows were 1.52 and 1.81 seconds, respectively. Therefore, many studies have focused only on estimating the minimum (critical) accepted lead and lag gaps based on the relative speed between vehicles.

In this study, video recordings from the M60 J10 were used to show the effect of relative speed on the size of the accepted lead and lag gaps. Speeds of vehicles were estimated by drawing screen lines to cover a distance of 99m (i.e. 9 consecutive white road markings, 11m each, which could be covered by the video camera). The cases when the cooperative behaviour between drivers could be identified from the data were excluded since it is not possible to estimate speeds of vehicles during such processes. However, it is believed that there are some cooperative cases which could not be identified from the data and which therefore may affect the accuracy of the results. The results of the accepted lead and lag gaps are shown in Figure 4-34.

The dashed lines in the figure represent the minimum lead or lag gaps and suggest that the higher the speed differences, the higher the required lead and lag gaps. The minimum lead and lag gaps were about 0.2 seconds or less in cases where the differences in speeds are positive, as shown in the figure.

The average observed lead and lag gaps were 1.78 and 3.25 seconds respectively when the flow of the shoulder lane and the merge traffic during the data collection were 890 and 680 veh/hr, respectively.

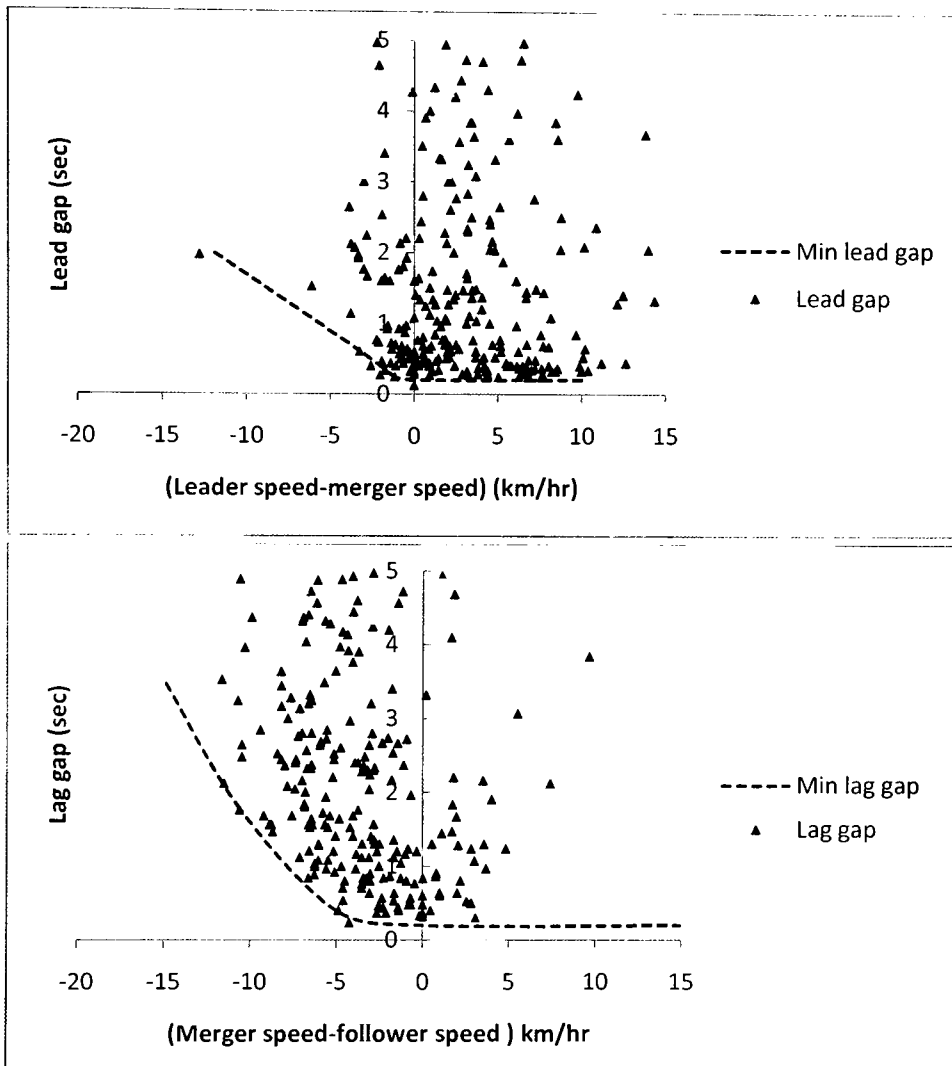

Figure 4-34 Relationship between relative speeds on the size of accepted lead and lag gaps

## 4.9. Data related to RM

### 4.9.1. Estimation of critical occupancy values for UK motorways

#### 4.9.1.1. Introduction and background

Occupancy is the percentage of time a traffic loop detector embedded in the road pavement is occupied by vehicles (Hall *et al.*, 1986). Unlike traffic density (as used in the fundamental diagram of traffic flow parameters), occupancy can easily be measured from traffic loop detectors that are located regularly around many motorway junctions. Hall *et al.* (1986) concluded that time occupancy can describe traffic conditions (i.e. normal and congested) in a similar way to that of traffic density. Figure 4-35 shows the

flow-occupancy relationship using data taken from upstream detectors' station from the M6 J23 motorway site for a period of 5 days covering low to congested flow conditions. The figure shows how this relationship is similar to that for flow-density.

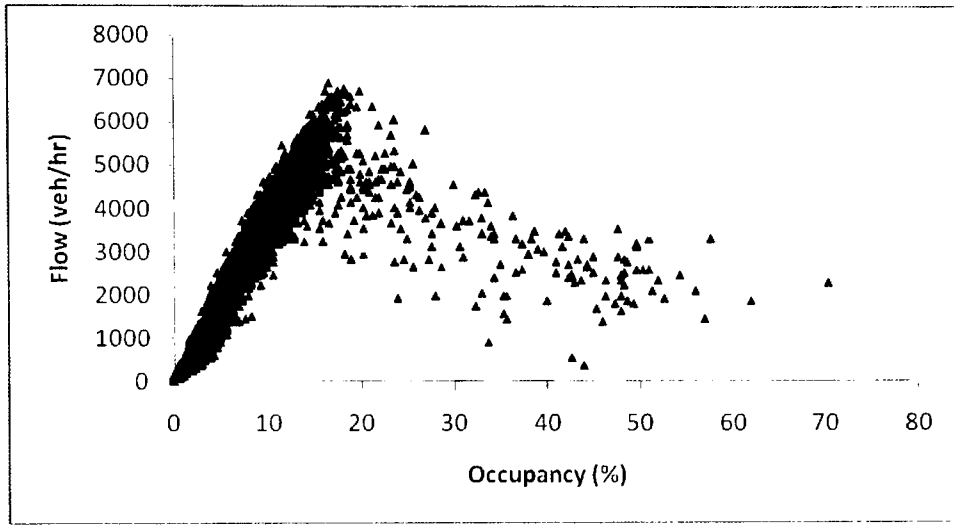

Figure 4-35 Flow-occupancy relationship based on data from the M6 J23 (3-lane motorway)

An attempt has been made to demonstrate the relationship between density (K) and occupancy (O) based on the flow and speed data to obtain density (i.e.  $K = \text{flow}/\text{speed}$ ) from loop detectors. Figure 4-36 shows this based on data from 5 detectors on the M6 J23. The figure shows that there is a good correlation between these two parameters especially at low values of occupancy (i.e. at normal traffic conditions). This finding is similar to that which has been reported by Heydecker and Addison (2008) when they used MIDAS data taken from the M25 motorway site.

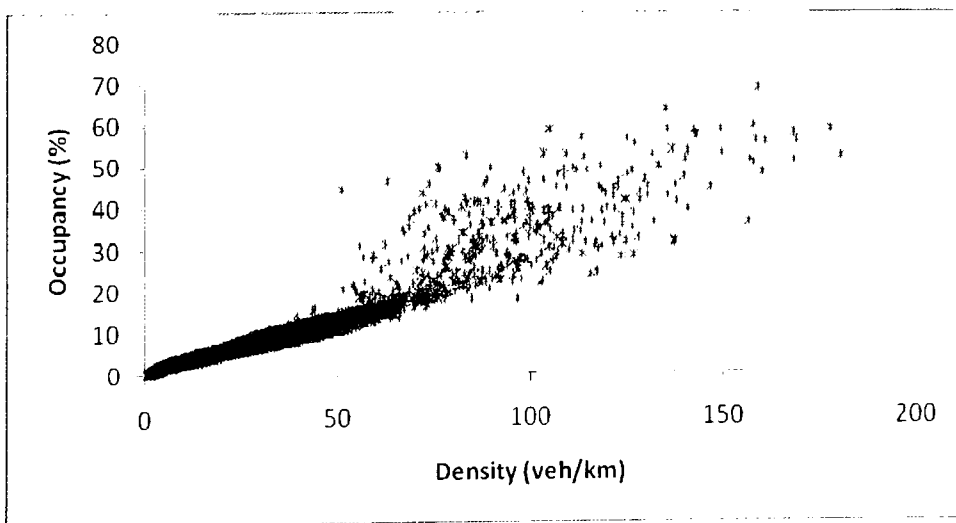

Figure 4-36 Occupancy-density relationship based on data from the M6 J23 (3-lane motorway)

The results in the figure support the linear relationship (see Equation 4-16, as presented by Papageorgiou, 1991) between traffic density ( $k$ , in veh/km) and time occupancy ( $O$ , in %).

$$O = \frac{(k)(g)}{10 N} \quad \text{Equation 4-16}$$

where,

$g$  is the average length of vehicles plus the length of the loop detector (m), and  
 $N$  is the number of lanes.

The term “critical occupancy,  $O_{cr}$ ” is extensively used to define the limit between normal and congested traffic situations since the  $O_{cr}$  represents the occupancy value for flow rates at capacity (Smaragdis *et al.*, 2004). Previous research has suggested a range for  $O_{cr}$  values. For example, Hall *et al.* (1986), based on data from Queen Elizabeth Way in Ontario, found that  $O_{cr}$  measured at loop detectors stations upstream of merge sections lies between 19 and 21%. The Minnesota Department of Transportation used a value of 18% to identify congested from normal conditions. Based on simulation results, Sarintorn (2007) concluded that  $O_{cr}$  for the Pacific Motorway in Australia ranged from 17-20%. Zhang and Levinson (2010) used time occupancy to indicate the occurrence of bottlenecks using data taken from loop detectors in the USA. When the occupancy is less than 20%, traffic is regarded as not congested; when occupancy lies between 20 and 25% the traffic is regarded to be in the transitional phase while the congested phase is when the occupancy exceeds 25%.

#### 4.9.1.2. Application of occupancy in RM

Currently, time occupancy is the main parameter in triggering most of the existing RM algorithms (e.g. ALINEA) as these controls use occupancy to judge the need to trigger the RM control devices, to calculate the required timing for traffic signals and finally to switch off the traffic signals. Therefore, using inaccurate values for critical occupancy ( $O_{cr}$ ) can lead to improper use for RM and this will affect the ability of these devices in the alleviation of traffic congestion. The use of values lower than needed to trigger the traffic signals will cause further unnecessary delays for merging traffic.

#### 4.9.1.3. Methodology

In this work, motorway MIDAS data from upstream and downstream loop detectors from 4 motorway sites were used. These sites were the M56 J2 (two lanes), the M60 J2 (three lanes), the M6 J23 (three lanes) and the M6 J20 (four lanes).

The method used was suggested by Hall *et al.* (1986) which requires estimating average occupancy for each given flow rate within intervals of  $\pm 100$  veh/hr and for each traffic condition (i.e. normal to congested conditions). The method used a trial value of critical occupancy ( $O_{cr}$ ) to differentiate between normal and congested traffic conditions. After undertaking some trials, the occupancy value which gives maximum flow at normal traffic conditions is set to be the critical value. A simple computer program using Compaq Visual FORTRAN 2005 was written in order to speed up the computational process for this piece of analysis (see Appendix C for details of the computer program).

#### 4.9.1.4. Results and discussions

Figure 4-37 to Figure 4-40 show the possible shapes for the flow-occupancy relationships for different trials of critical occupancy ( $O_{cr}$ ) values for the M56 J2, the M60 J2, the M6 J23 and the M6 J20, respectively. In these figures, the word “normal” represents the results for the cases where the occupancy values are not higher than the trial value of the  $O_{cr}$  while the word “congested” represents the results for the other cases (i.e. where the occupancy values are higher than  $O_{cr}$ ).

For the M56 J2, as shown in Figure 4-37, trial values of  $O_{cr}$  from 21 to 26% were used. The results in the figure suggest that the  $O_{cr}$  value is about 26%. Lower values (i.e. 25% and less) are not critical values because these gave flow rates for a congested regime equal or higher to those at a normal regime. In the same way, and based on these figures, values of 20-21%, 23% and 22% are suggested for the M60 J2, the M6 J23 and the M6 J20, respectively.

Although both the M60 J2 and the M6 J23 have same number of lanes (i.e. 3 lanes), the  $O_{cr}$  values obtained for these two sites were different (20-21% for the M60 J2 and 23% for the M6 J23). This may be related to the position of the downstream loop detectors that were used in these sites. Another reason is that the M60 J2 is a weaving section where there is a merge section (on ramp) shortly followed by a diverge section (off ramp) while at the M6 J23 there is no diverge section close to the M6 J23 merge section.

Table 4-14 compares the  $O_{cr}$  values with desired occupancy ( $O_{des}$ ) values that are currently in use to trigger the RM devices on selected motorway sites. The value that is used to trigger the RM at the M56 J2 was not given due to a lack of data. The table shows that for the M6 J23 and the M6 J20 sites, the values which are currently used to operate the RM devices at these sites are higher than those obtained from analysing the data. This will



cause delays in the operation of the RM after the start of traffic congestion. For the M60 J2, the value used is much closer to the estimated value.

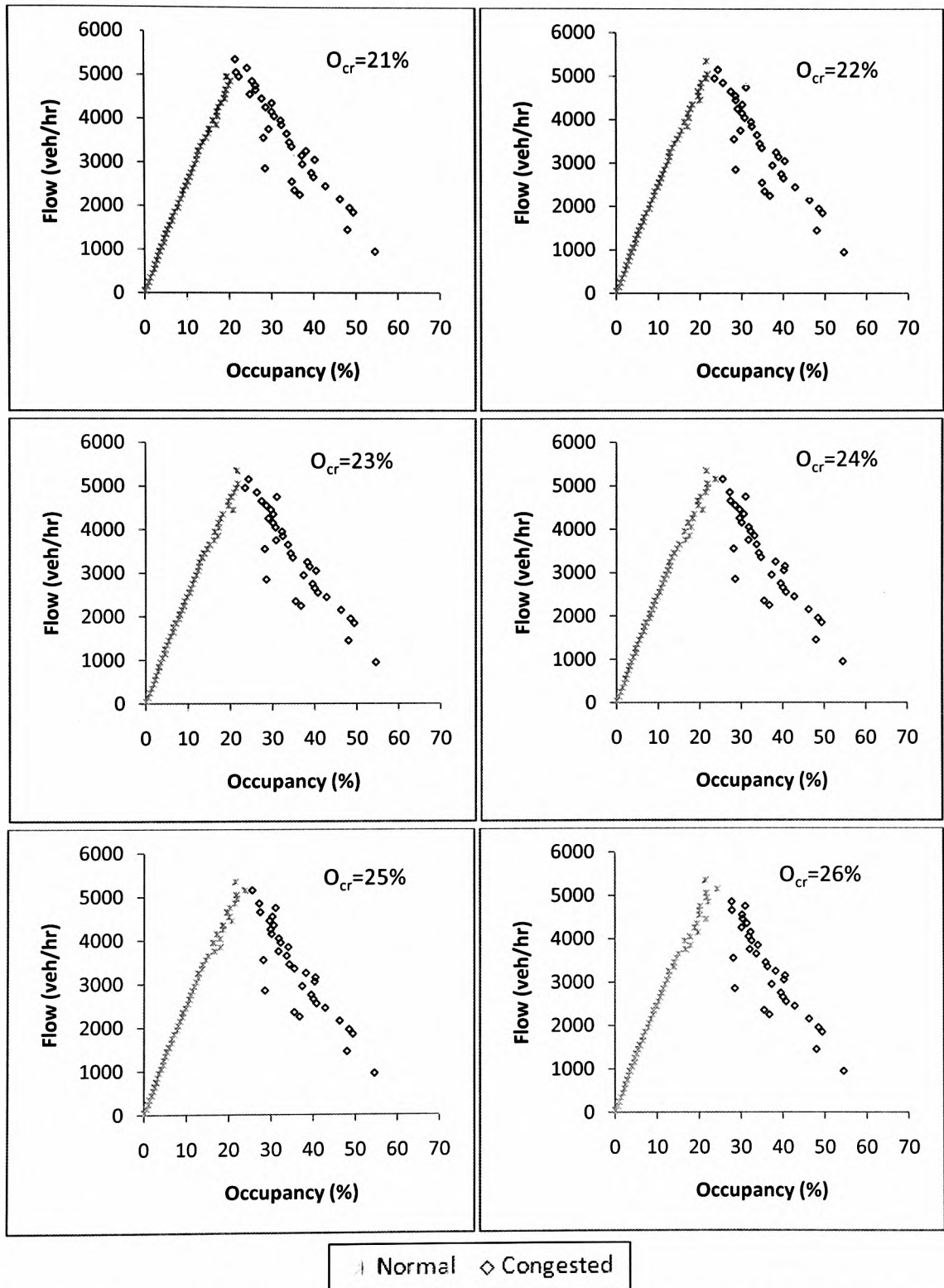

Figure 4-37 Flow occupancy relationship for the M56 J2 (2-lane motorway) with different trial values of  $O_{cr}$

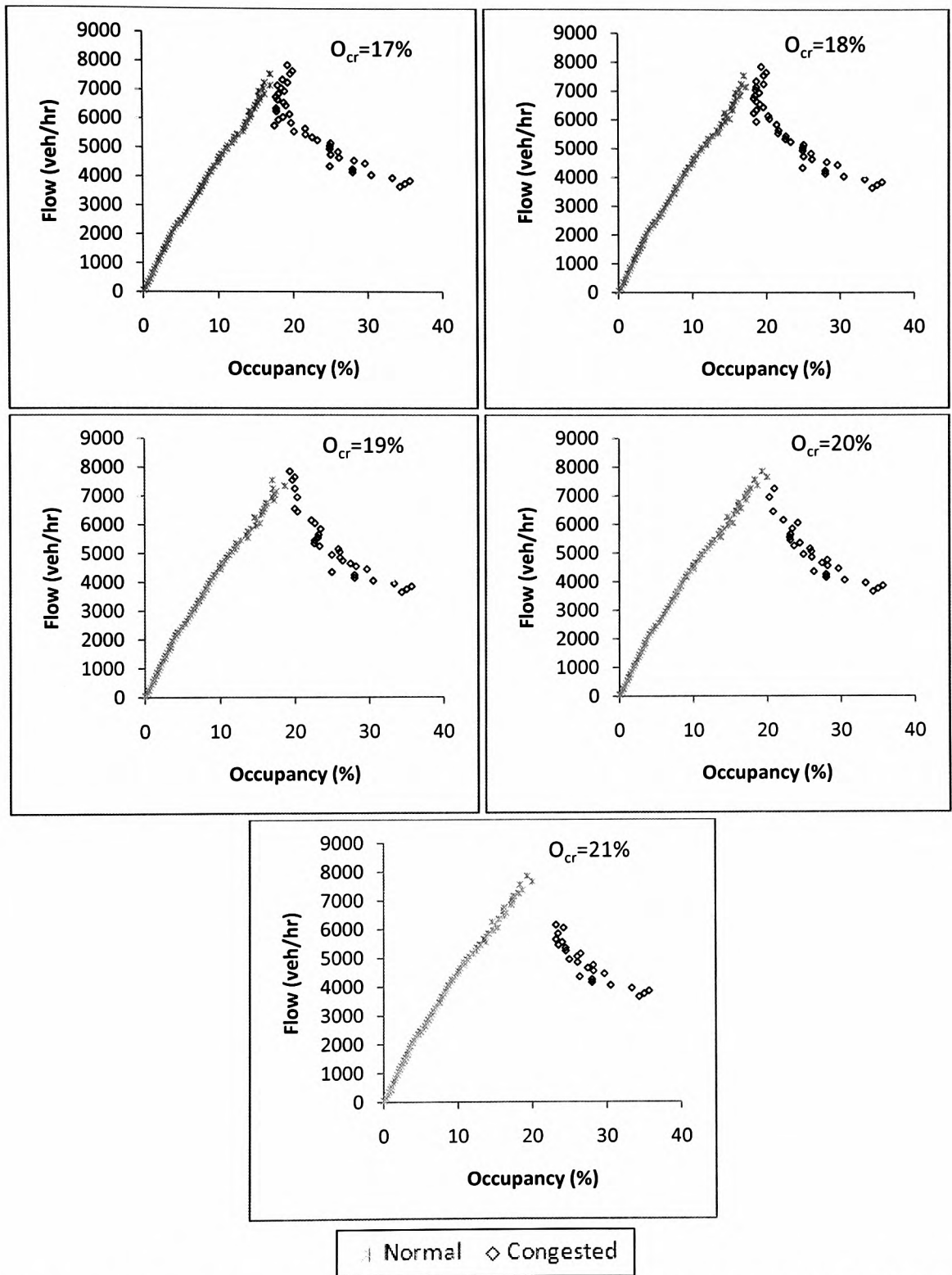

Figure 4-38 Flow occupancy relationship for the M60 J2 (3-lane motorway) with different trial values of  $O_{cr}$

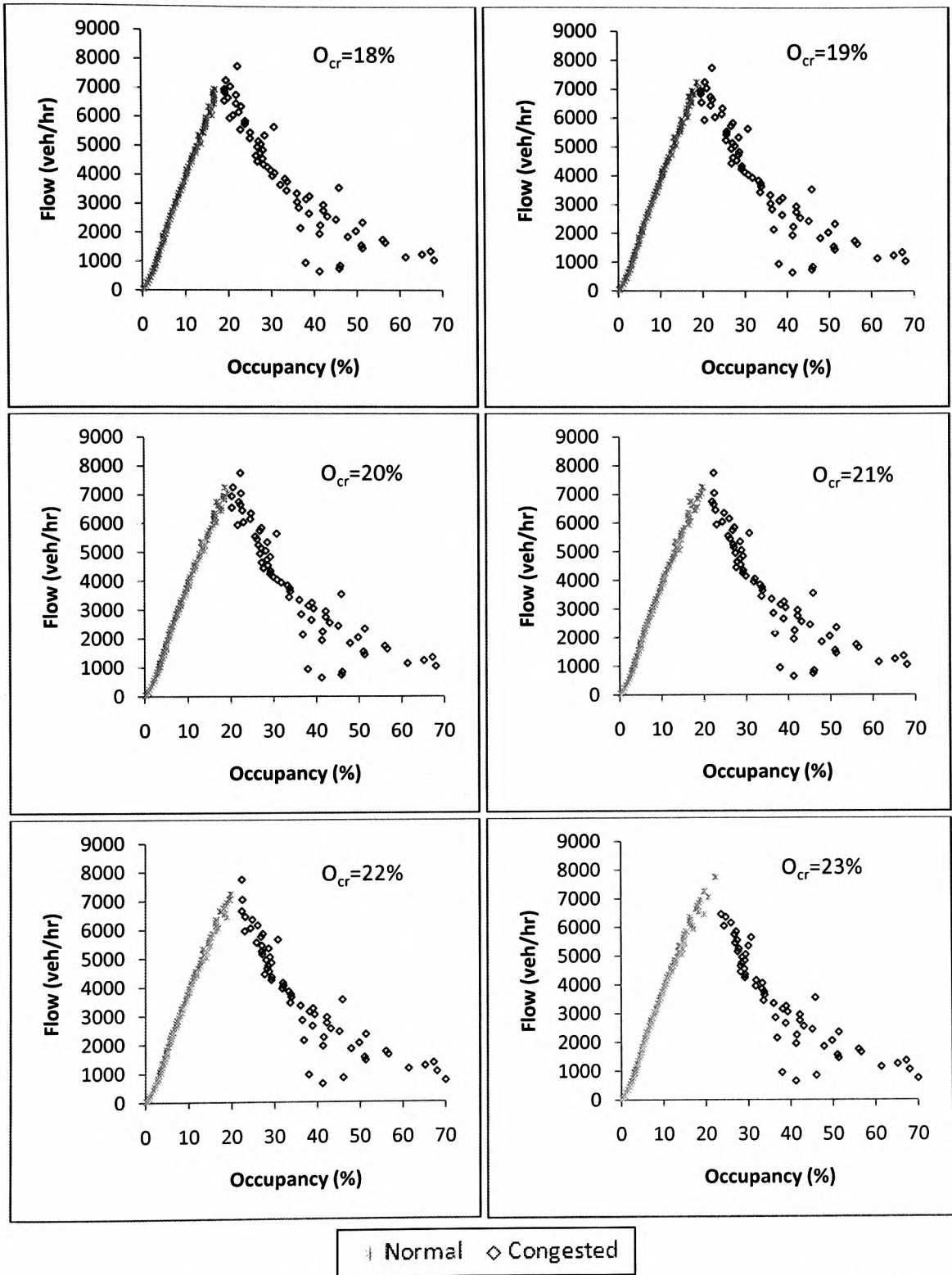

Figure 4-39 Flow occupancy relationship for the M6 J23 (3-lane motorway) with different trial values of  $O_{cr}$

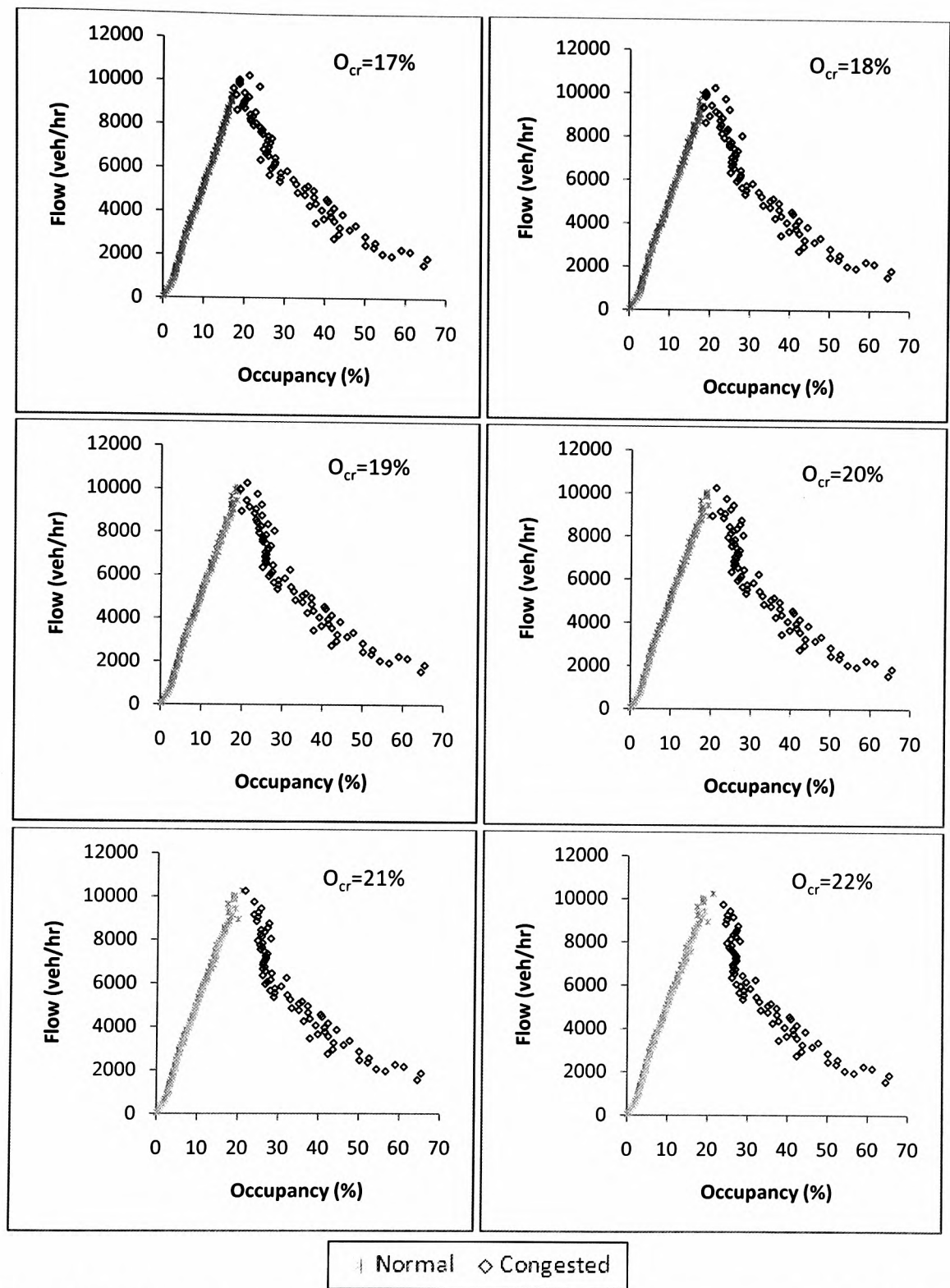

Figure 4-40 Flow occupancy relationship for the M6 J20 (4-lane motorway) with different trial values of  $O_{cr}$

Table 4-14 Estimated  $O_{cr}$  and  $O_{des}$  values in use in some RM sites in UK

Site	M6 J23	M6 J20	M60 J2
Estimated critical occupancy (%)	23	22	20-21
$O_{des}$ values in use in RM (%) <sup>1</sup>	28	25.5	19

(1) These values were obtained from Atkins Manchester based on interior communications in 2009

### 4.9.2. Compliance of drivers with the timings of RM signals

Video recordings from the M56 J2 have been used to show drivers' compliance with the RM signal timings. Table 4-15 shows the typical time periods for traffic signals installed at the M56 J2 and the number of vehicles going through during the green, amber and red periods. The "red-amber" period in the table is applied in the UK in order to alert drivers about the forthcoming green period (EURAMP, 2007). The table suggests that drivers do respect the red timings but drivers go through the amber periods in a similar way as they do in green periods. On average, 2.76 (about three) vehicles per lane go through every 5 seconds on green and amber. This behaviour maybe because there is no risk associated with such movements during the amber timings as there is no conflicting traffic as is usually found at normal signalised junctions.

Table 4-15 Vehicles going through during cycle time periods for the M56 J2 RM

Signal timings (sec)				No. of vehicles going through	
Red	Red-amber	Green	Stopping amber	During red	During green and amber
22	2	2	3	1	5
22	2	2	3	0	6
22	2	2	3	0	6
20	2	2	3	0	4
14	2	2	3	0	5
14	2	2	3	0	6
11	2	2	3	0	6
11	2	2	3	0	4
12	2	2	3	0	5
12	2	2	3	0	6
12	2	2	3	0	7
6	2	2	3	0	7
4	2	2	3	0	5
4	2	2	3	0	6
4	2	2	3	0	5
9	2	2	3	0	4
5	2	2	3	0	6
6	2	2	3	0	5
4	2	2	3	0	7

### 4.9.3. Effectiveness of RM

Using real information to test the effectiveness of RM controls requires data for the cases of with and without RM controls at similar levels of flow rates. If such data is available, one could compare the traffic parameters such as speed, flow and travel time between the

two cases. Unfortunately, such data is not readily available and could not be easily gathered from motorway sites. Therefore, loop detectors' data taken from some sites during the operation of RM systems are only used in order to examine the ability of the RM control in preventing traffic congestion and also in preventing the congestion propagating upstream of the merge section.

Average five minutes of speed and occupancy data taken over a period of seven days from the M60 J2 (3 lanes), the M6 J23 (3 lanes) and the M6 J20 (4 lanes) motorways were used in addition to two days of data from the M56 J2 motorway.

Figure 4-41 shows an example for the data obtained from the M6 J20 site. The figure represents average speeds taken from upstream and downstream detectors of the merge section as well as the occupancy obtained from the downstream detectors. Figure 4-41-b, based on data from downstream detectors, shows that the RM could not prevent the onset of congestion as there were some cases with congestion were happened during the week when speeds were below 60 km/hr. Also, in all of these cases, the congestion was propagated upstream of the merge section as shown in Figure 4-41-a. The RM was in operation in cases where the downstream occupancy, given in Figure 4-41-c, exceeded the desired value of 25.5% as given in Table 4-14.

For the other selected motorway sites, similar findings were achieved, as shown in Figures D1-D3 in Appendix D. However, these findings do not suggest that RM is not capable of alleviating traffic congestion since no real data is available for the cases of without RM controls as discussed above.

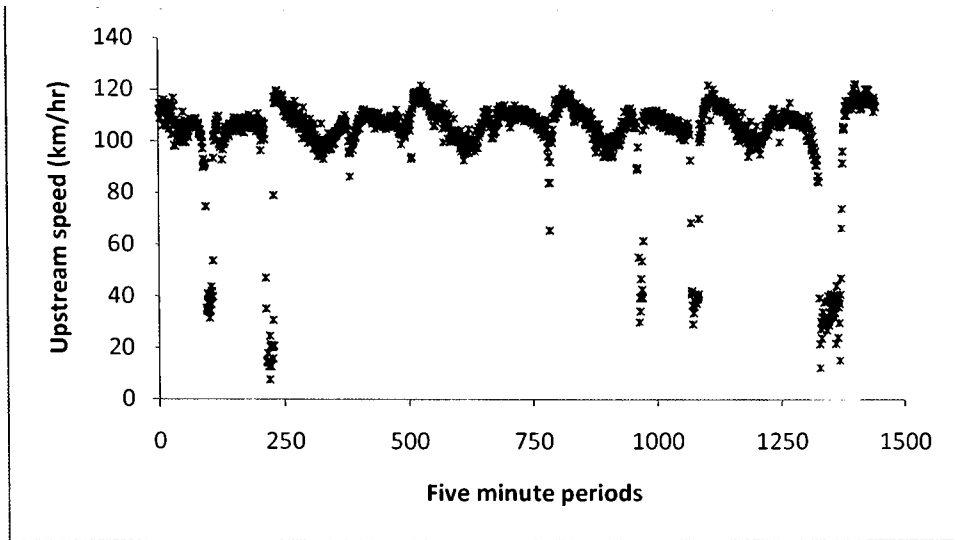

(a) Upstream speed

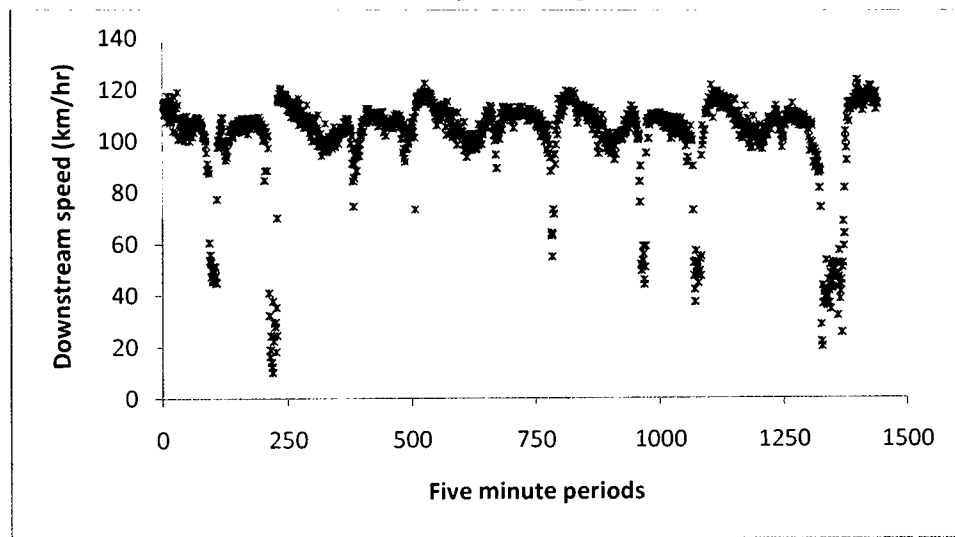

(b) Downstream speed

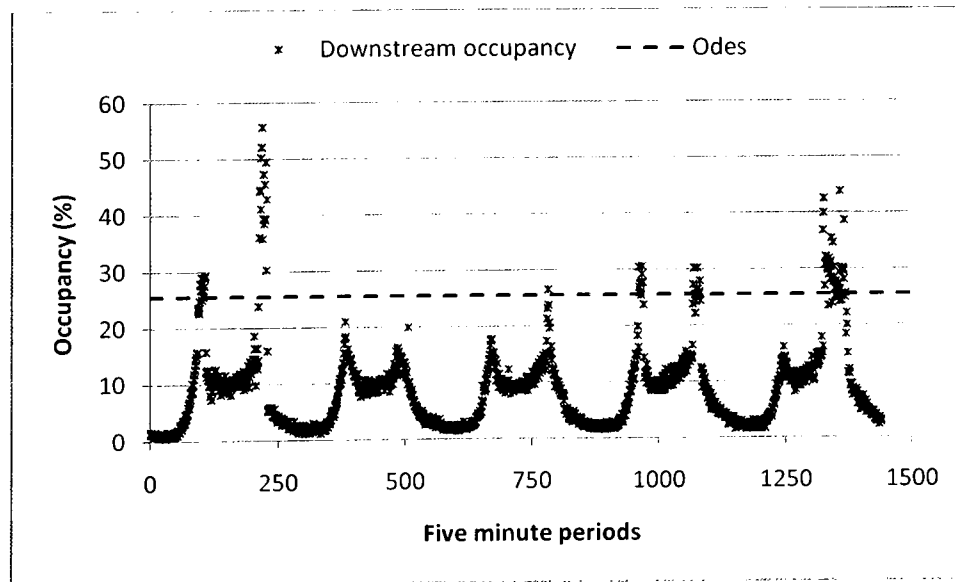

(c) Downstream occupancy

Figure 4-41 Average speed and occupancy values for the M6 J20 site

## 4.10. Summary

This chapter presented the analysis of data taken from different motorway sites, as summarised below. Such data were used in developing, verifying calibrating and validating the simulation model as will be discussed in Chapters 5 and 6.

- Over 4 million leader–follower pairs of real data taken from UK motorway sites were analysed to study the effect of vehicle types on close following behaviour (see section 4.4). The data have been filtered to ensure that “free flowing” vehicles are excluded from the analysis using a robust methodology for defining maximum gap headways and maximum speed differences. The results suggested that there is no evidence that the spacings between successive vehicles are significantly affected by the type of the leader.
- Motorway Incident Detection and Automated Signalling (MIDAS) data, taken from many locations on different motorway sites, have been the main source of data used in order to study how traffic flow is distributed among the available number of lanes for a directional movement (see section 4.5 for further details). In addition, new models for HGVs lane utilisation have been developed for motorways with three and four lanes sections.
- Data taken from motorway sections with three lanes have been used in order to fit some headway distribution models (see section 4.6).
- Video recordings collected from motorways normal sections with 2, 3 and 4 lanes are used to focus on lane changing behaviour (see section 4.7).
- Video recordings collected from motorway merge sections were used to get a better understanding of drivers’ behaviour in term of the interactions between motorway and merge traffic (see section 4.8).
- MIDAS and also some video recordings taken from some RM sites in the UK have been analysed to estimate critical occupancy values for different motorway sites (see section 4.9.1), to test the compliance of drivers with RM signals (see section 4.9.2) and to test the ability of RM controls to prevent the occurring of traffic congestion (see section 4.9.3).



---

## CHAPTER FIVE : MODEL DEVELOPMENT

### 5.1. Introduction

In the previous chapter, the analyses of the data taken from UK motorways were presented. This chapter uses some of the presented data in developing the simulation model for motorway traffic and particularly for merge sections. A micro-simulation technique has been selected in this study because of the ability of such techniques in representing the interaction between individual vehicles. The development of such a microscopic model required information about vehicles'/drivers' characteristics and also required the selection/developing of suitable algorithms for car following, lane changing and gap acceptance sub-models (rules). These rules then needed to be programmed using a suitable programming language in order to test the performance of the model before it could be applied.

In this study, the Compaq Visual FORTRAN-2005 programming language is used in developing the simulation model. This is because the FORTRAN language has been widely used in engineering applications; also the selected version could provide a reasonable visual representation for vehicles' movements and interactions.

### 5.2. Geometric layouts

The model is designed to be flexible in terms of its section geometry and it can be used for up to five motorway lanes with one or two lanes for the ramp entry. Figure 5-1 shows typical layouts that are considered in the model. All the geometric parts such as the section length, the acceleration lane length, the position of the ramp section and the position of traffic signals are easily modified from the input file. The model can also deal with a basic section (Highway Capacity Manual (HCM), 2010) where there is no on-ramp or off-ramp within the section. Both the warm-up and the cool-off sections have been included. The warm-up section is the required length at the beginning of the simulation section for vehicles to be settled while the cool-off section is the required length after the end of the effective section to ensure that the car following and lane changing rules are applied consistently in the model even after the end of the effective section (Al-Obaedi and Yousif, 2011). Values of 500m and 1000m are applied as a default for these warm-up and cool-off sections, respectively.

### 5.3. Count stations

Double traffic loop detectors, as shown in Figure 5-2, are simulated in order to collect the data from the model. The user could select the interval of the unit length where the detectors are located. The time intervals for the results obtained from the detectors are also subject to user selection. The data taken from detectors gave the average speed, flow, headway, delay and occupancy per lane and also for the overall cross-section. The traffic loop detectors used for the purpose of modelling RM are included and were used at relatively lower time intervals (usually 15-60 seconds). The user could stipulate the specific locations for such detectors on both the slip road and on the motorway sections. It is worth mentioning that the detectors counters will not start gathering data until passing a period of time called the “warm-up time” to ensure that some vehicles have passed the total section length. The default value for the warm-up time of 10 minutes has been used based on the findings by Yousif (1993). In calculating the required parameters, once a vehicle touches the start of the first and the second loops as shown in Figure 5-2, T1 and T2 will be registered respectively. T3 represents the time at which the full vehicle crosses the first loop. The difference between T3 and T1 represents the time at which the first loop is occupied by the vehicle. The difference between T1 and T2 is used in calculating the speed of a vehicle. It is obvious that, in most cases, a vehicle could not reach the line of the measurement exactly at the multiples of the scan time ( $\Delta t$ ) (i.e. a vehicle will cross the line of measurement (for T1, T2 or T3) between the times  $t$  and  $t+\Delta t$ ). Therefore, the accurate times (T1, T2 and T3) are estimated using interpolation calculations based on the speed and position of vehicles at times  $t$  and  $(t+\Delta t)$ .

### 5.4. Scanning time

Scanning time ( $\Delta t$ ) is the interval of time where the model updates the information of the system (i.e. positions and speeds of the vehicles). The selection of a small interval of time for the scanning time such as 0.1 second will provide detailed information but will, however, make the simulation too complex and increase the running time unnecessarily. On the other hand, for longer periods such as 2 seconds or more, there might be some interactions or events that will not be covered. Most of the existing micro-simulation models use either 1 or 0.5 second as the scan time. Gipps (1981) recommended that the scan time should be related to the driver's reaction time and used a value of 2/3 seconds. For this study, the default value of 0.5 seconds has been used as recommended by

Yousif (1993) who tested a range of values from 0.1 to 2.0 seconds. The selected value of 0.5 seconds is close to that used by Gipps (1981).

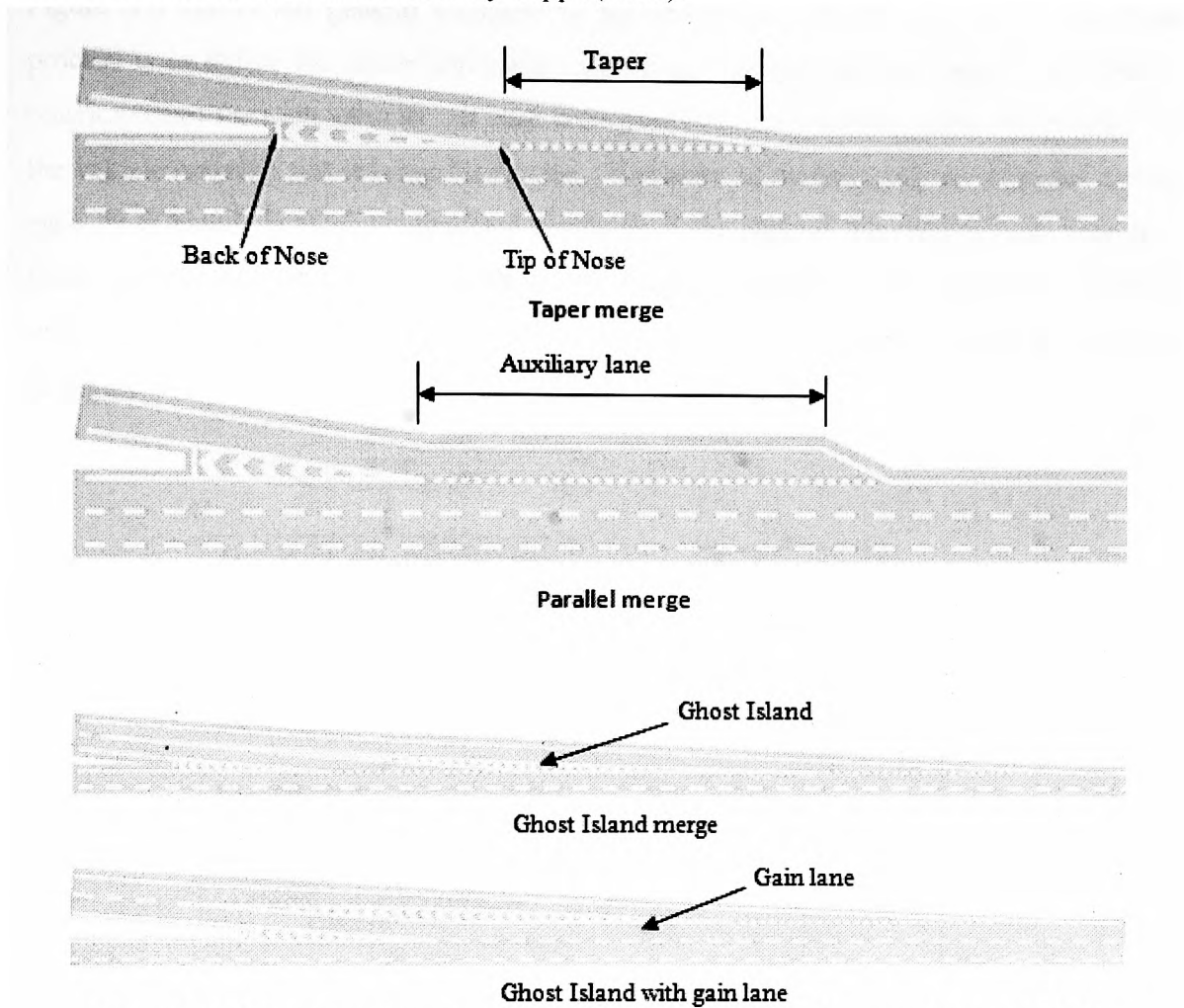

Figure 5-1 Geometric layout considered in the model (Highways Agency, 2008)

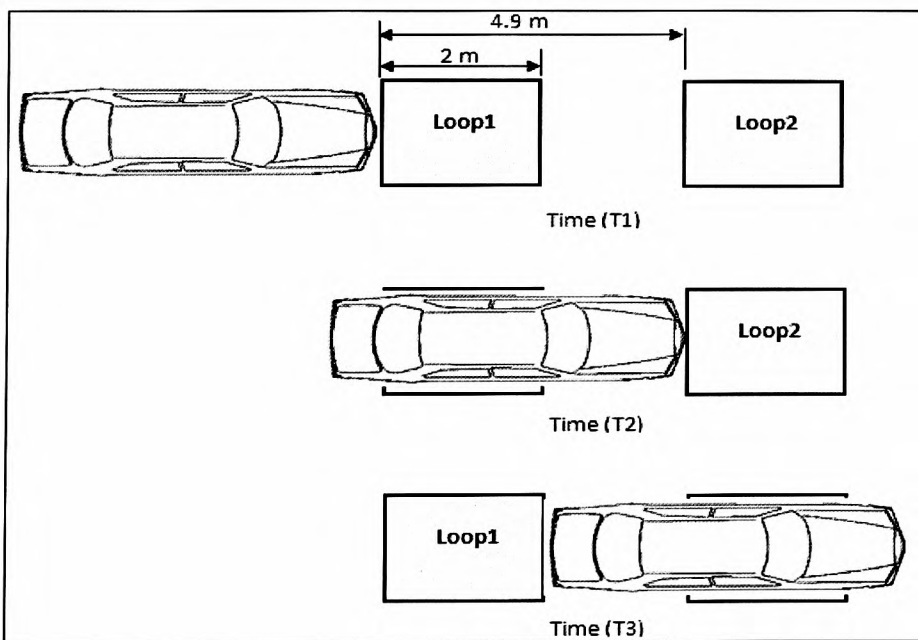

Figure 5-2 Measurements of the timings used in the calculations for speed and occupancy

### 5.5. General structure of the simulation model

Figure 5-3 shows the general structure of the developed simulation model. The first process is to define the driver's/vehicle's characteristics (e.g. desired speed and driver's reaction time) for each vehicle. At each scan time ( $\Delta t$ ), the model updates information on the vehicle entering and leaving the system. The order of dealing with the vehicles during each  $\Delta t$  is based on their longitudinal positions at the start of the current scan time (i.e. from end to start of section including the warm up and cool-off sections). This is undertaken by numbering and renumbering the vehicles in the system at each  $\Delta t$  as shown in Figure 5-4.

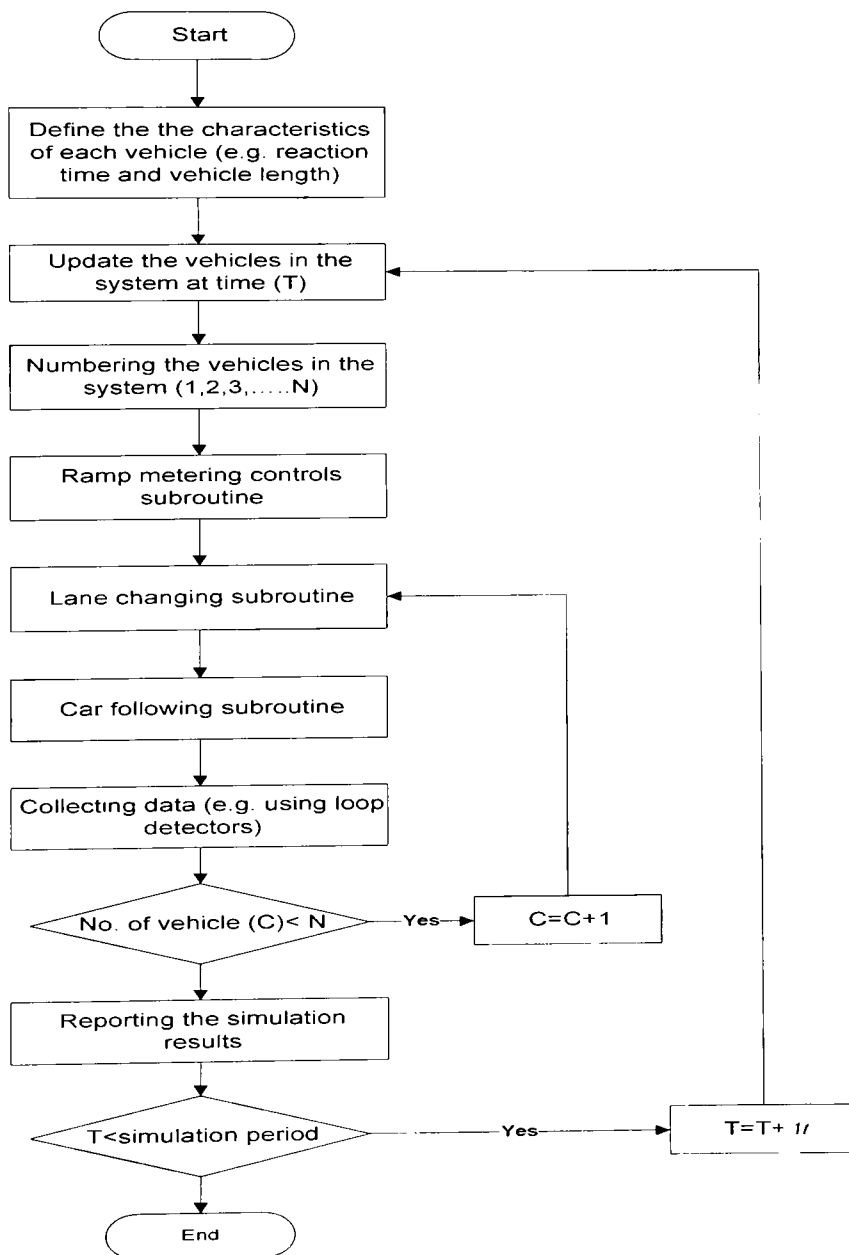

Figure 5-3 General structure of the developed model

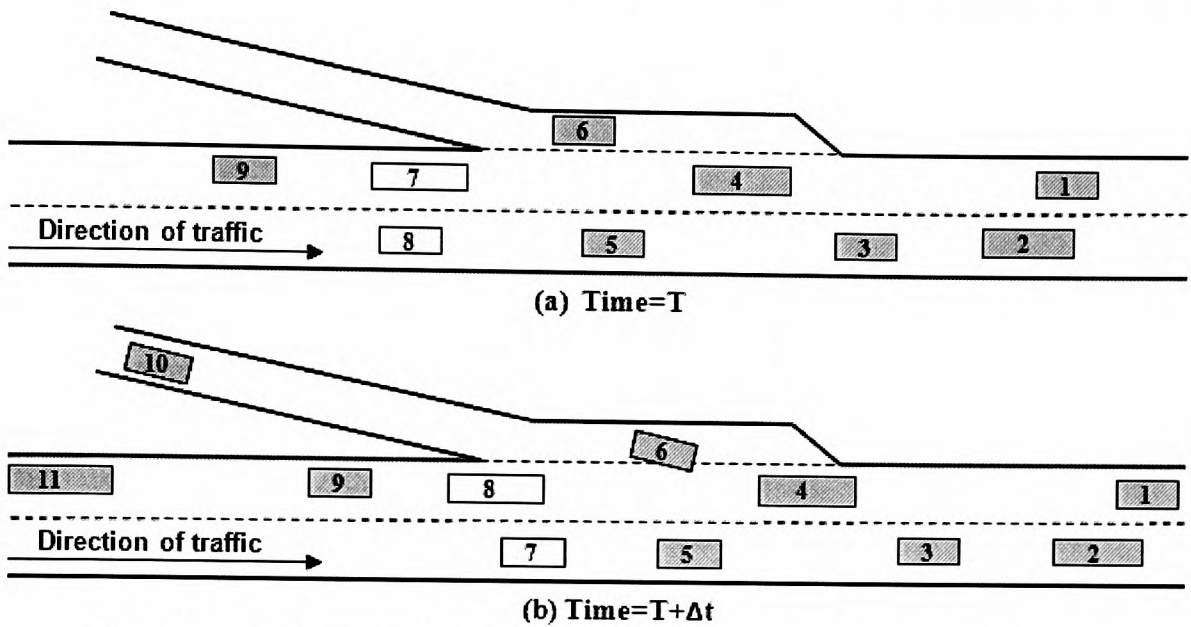

Figure 5-4 Numbering (a) and renumbering (b) the vehicles at each scan time

## 5.6. Drivers'/vehicles' characteristics

### 5.6.1. Drivers' reaction time

Reaction time indicates the time lag between the detection of a stimuli and the application of a response (Zhang and Bham, 2007). According to O'Flaherty (1986), the length of perception time varies considerably since it depends upon many factors such as the distance to object, the natural rapidity with which the driver reacts and the optical ability of the driver.

Table 5-1 gives a summary of some of the main work in determining drivers' reaction time. The "surprised" situation relates to cases where drivers do not have prior information about the test to measure their reaction times. Maycock *et al.* (1999) used the term "un-alerted" to represent the "surprised" situation. For "alerted" situations, drivers know and expect what could happen while they are driving. Most researchers have reported on the difficulties associated with accurately estimating drivers' reaction time.

Table 5-1 Summary of drivers' reaction time based on previous research

Researcher	Median reaction time (sec)	Situations
Johansson and Rumer (1971)	0.73, 0.54	Surprised, Alerted
Lerner <i>et al.</i> (1995)	1.44	Surprised
Maycock <i>et al.</i> (1999)	1.2	Surprised
Zhang and Bham (2007)	0.6	From car following data

Figure 5-5 shows the cumulative distribution of drivers' reaction time according to Johansson and Rumer (1971) and suggests that the reaction time for surprised situations is about 0.75 of that for alerted situations.

In this study, drivers' reaction times were obtained from Figure 5-5 by generating random numbers from a uniform distribution and setting these random numbers to be equal to the cumulative distribution in the figure. Figure 5-5 also shows a numerical example (for the case of a surprised driver) when the random number is 0.75 which produces a driver's reaction time of 1.1 sec. Distinguishing between surprised and alerted situations is undertaken by assuming that drivers will be alerted in situations where traffic density exceeds a value of 37 veh/km/lane as suggested by Benekohal (1986) and Yousif (1993).

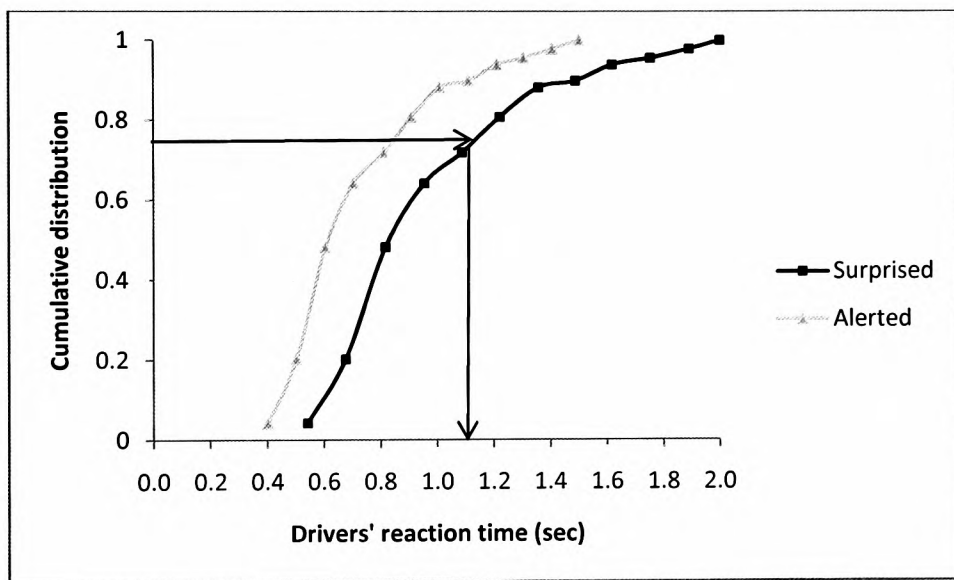

Figure 5-5 Drivers' reaction time based on Johansson and Rumer (1971) (Source: Yousif, 1993)

### 5.6.2. Vehicle lengths

In the model, vehicle lengths affect the calculations of the acceleration/deceleration rates for the car following rules as well as for the estimation of the gaps required for lane changing, as will be discussed later in this chapter. El-Hanna (1974) reported that vehicle lengths are normally distributed with mean and standard deviation as shown in Table 5-2 for cars and HGVs. Chin (1983) found different results when the mean length of HGVs was 6.81m.

Table 5-2 Vehicle lengths (Source: El-Hanna, 1974)

Vehicle type	Mean (m)	$\sigma$ (m)
Cars	4.2	0.4
HGVs	11.2	2.4

The earlier findings by El-Hanna (1974) were used in many studies within the UK (see for example, Skabardonis (1981); Zia (1992); Zheng (2003) and Wang (2006)). One should be careful when applying Table 5-2 with a normal distribution (as used by the majority of the above referred studies) since such a normal distribution will show HGVs' lengths varying between 4 to 18m. It is obvious that HGVs do not have such short lengths.

In this study, this factor has been examined using the IVD from the M42. As was mentioned in section 4.4.3, the lengths of vehicles have been investigated from typical manufacturers' data sources and indicate that a value of 5.6m is the minimum length for HGVs. Therefore, this value is used in the developed model to distinguish between cars and HGVs. Vans are regarded either as cars or HGVs based on their lengths when compared with the value of 5.6m. The distribution of each group is obtained separately using a sample of about 60,000 vehicles. Surprisingly, the results shown in Table 5-3 indicated that the mean lengths for cars and HGVs are very close to those obtained by El-Hanna (1974). The hypotheses for the normality of vehicle lengths for both groups are rejected after using both Kolmogorov-Smirnov and Chi-square tests. Figure 5-6 and Figure 5-7 are respectively showing the histograms for the cars' and HGVs' distributions.

Table 5-3 Vehicle lengths (m) based on data from the M42

Vehicle type	Mean	Median	$\sigma$	Min	Max	Sample
Cars	4.2	4.26	0.45	2.3	5.6	53326
HGVs	11.4	10.4	4.3	5.6	25.5	5771

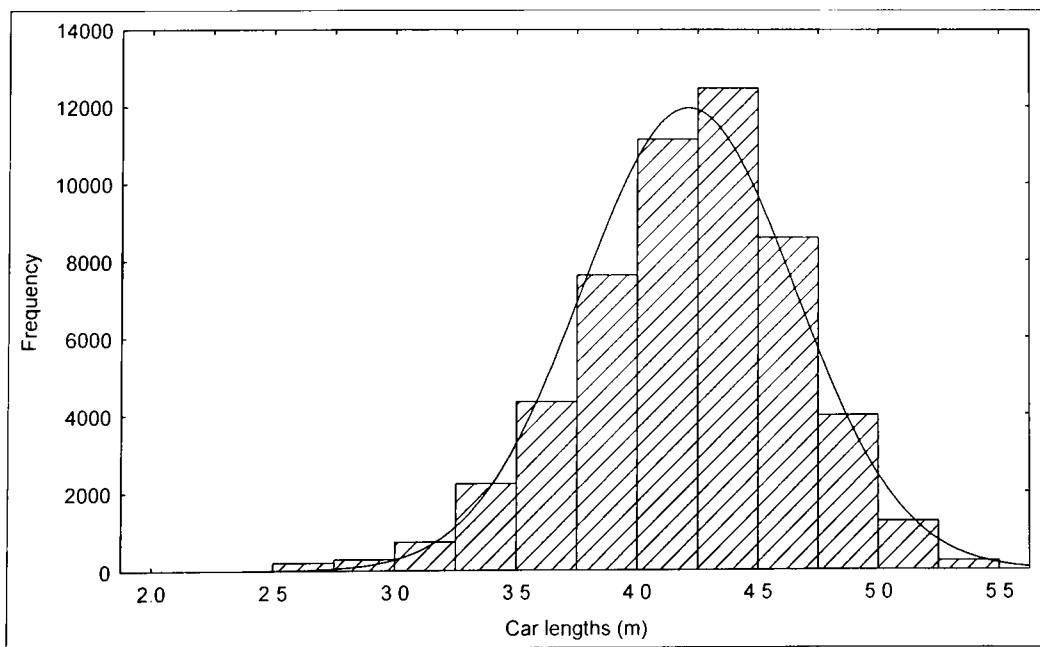

Figure 5-6 Distribution of car lengths based on data from the M42

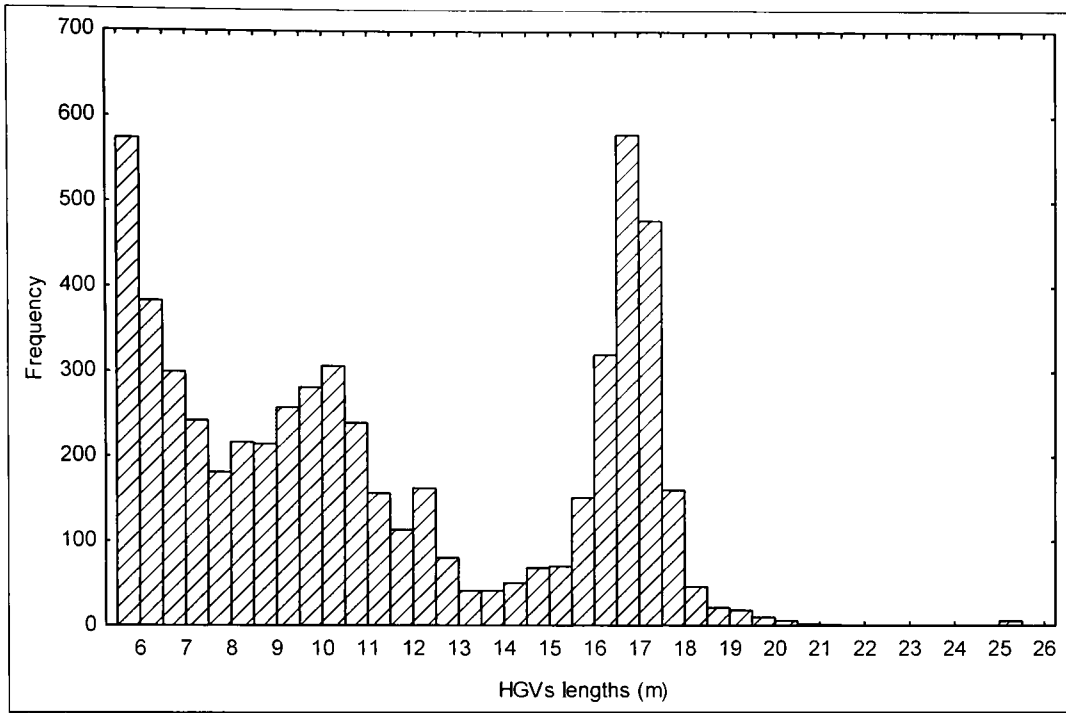

Figure 5-7 Distribution of HGVs' lengths based on data from the M42

In the model, vehicle lengths for each group are obtained from the cumulative distribution for these two groups as shown in Figure 5-8 and Figure 5-9 by generating two random numbers ( $R_i$  and  $R_j$ ) for each vehicle. As shown in Figure 5-10, the vehicle is regarded as a HGV if  $R_i$  is equal or lower than the percentage of HGVs in a given lane, otherwise it will be regarded as a small car.  $R_j$  is used in estimating the vehicle length, either from Figure 5-8 for small cars or from Figure 5-9 for HGVs, in similar way to that used in estimating drivers' reaction time.

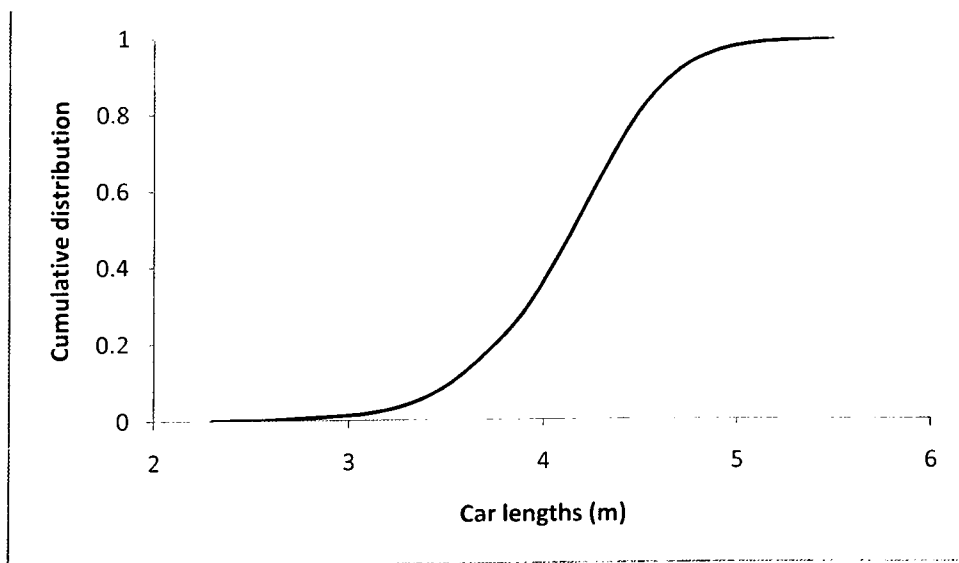

Figure 5-8 Cumulative distribution for car lengths based on data from the M42



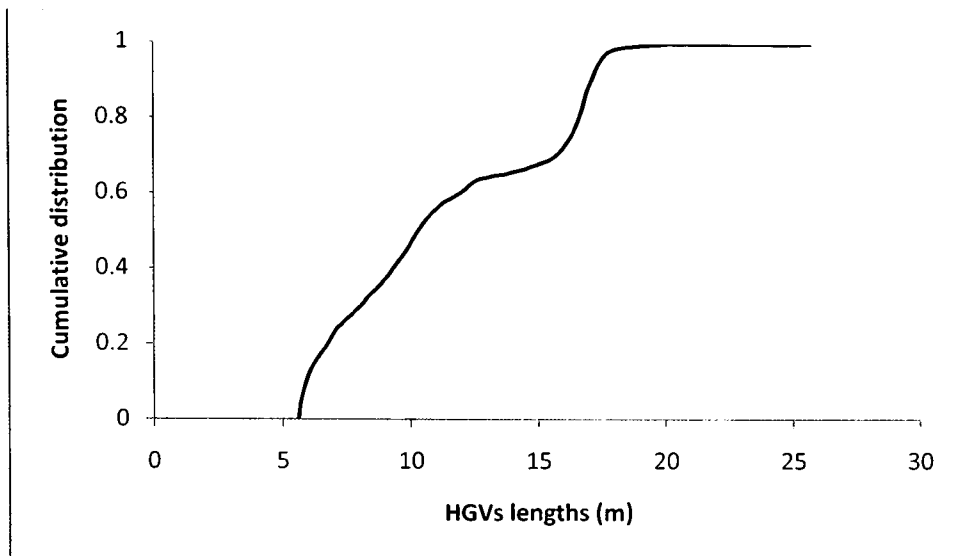

Figure 5-9 Cumulative distribution for HGVs' lengths based on data from the M42

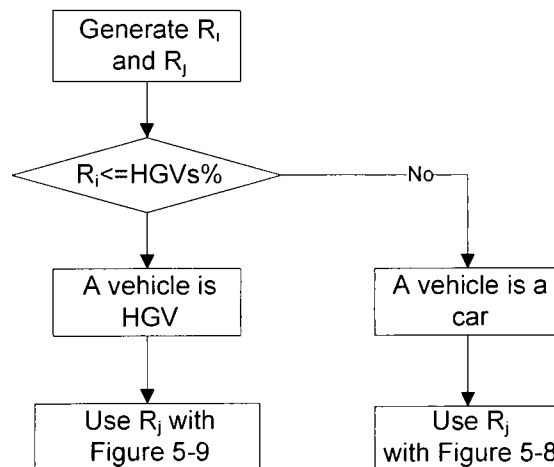

Figure 5-10 Method of estimating vehicle lengths

### 5.6.3. Vehicle acceleration and deceleration rates

The maximum and normal acceleration rates are used as reported by the American Traffic Engineering Handbook, ITE (1999) as shown in Table 5-4. It shows the maximum acceleration rates based on the mechanical limits for cars and HGVs. These maximum rates were also used in the updated version of the ITE (2010). For normal acceleration rates, the value of  $1.1 \text{ m/sec}^2$  was suggested. These maximum and normal acceleration rates are used in this study because of the absence of such data for UK vehicles.

For maximum deceleration rates, different values have been suggested according to previous research. The NETSIM, INTRAS, FRESIM and CARSIM simulation models used values of  $-3.6$ ,  $-6.4$ ,  $-4.6$  and  $-4.9 \text{ m/sec}^2$  respectively (Aycin and Benekohal, 2001). Yousif (1993), ITE (1999) and Goodman (2001) used a value of  $-4.9 \text{ m/sec}^2$  while Wu and McDonald (1994), Parker (1996) and Zheng (2003) used a value of  $-4.2 \text{ m/sec}^2$ . Wright

and Ashford (1999) suggested that 94% of passenger cars can achieve a deceleration rate of  $-7.6 \text{ m/sec}^2$  and only 13% of HGVs can reach such a rate. For the purpose of this study, a value of  $-4.9 \text{ m/sec}^2$  is used. It should be noted here that in alerted situations, the maximum deceleration rate of the follower is assumed to be  $-3.6 \text{ m/sec}^2$  as suggested by Benekohal (1986) and Yousif (1993).

For normal deceleration rates, Papacostas (2005) suggested that  $-3$  and  $-1.5 \text{ m/sec}^2$  are comfortable for seated and standing passengers respectively. In this study, the ITE (1999) normal deceleration rate of  $-3 \text{ m/sec}^2$  is used.

Table 5-4 The mechanical limit for acceleration rates ( $\text{m/sec}^2$ ) for passenger cars and HGVs for different speed levels (Source: ITE, 1999)

Speed (km/hr)	0-32	32-48	48-64	64-80	>80
Cars	2.3	2.0	1.8	1.6	1.4
HGVs	0.5	0.4	0.2	0.2	0.1

## 5.7. Traffic flow characteristics' inputs

This section describes how traffic flow parameters could be entered into the developed model. These include flow input, lane utilisation for traffic flow and, for HGVs flow, headway distribution and the desired speed.

### 5.7.1. Flow rates and traffic composition

Traffic flow rates and compositions (i.e. the proportion of HGVs) could be entered for both motorway and ramp entrance either per section or per lane. If the motorway flow is entered per section, the model will distribute the traffic according to the lane utilisation models developed in the previous chapter (see section 4.5) for motorways with 2, 3 and 4 lanes. The HGVs will be distributed using the HGVs' lane utilisation models given in Table 4-11 which consider the effect of total flow and total HGVs' flow for motorway sections with 3 and 4 lanes. For motorway sections with 2 lanes, the HGVs' lane utilisation models that were developed by Hollis and Evans (1976) are used. This is because of the absence of suitable data to estimate HGVs' distribution models for such sections. For a 2-lane ramp section, and if the flow rates and proportions of HGVs are not specified per lane, these flow rates and HGVs proportions will be equally distributed.

### 5.7.2. Headway distribution

Different models have been put forward in previous research for vehicles' arrivals as discussed in section 4.6. It has been suggested (Salter, 1996) that shifted negative

exponential and the double exponential distributions could be used with free and moderate flow rates. Both these distributions were used by Dawson and Michael (1966) for ramp and motorway traffic respectively. Wang (2006) used the negative exponential distribution for both motorway and merge traffic. Real data (see section 4.6) as well as other previous studies suggested that the generalised queuing model is applicable for higher flow rates (see for example, Skabardonis (1981), Zia (1992), Yousif (1993) and Zheng (2003)).

In this study, the double exponential, shifted negative exponential and the generalised queuing distributions are all integrated within the developed simulation model with the default values of parameters as obtained in section 4.6. The negative exponential headway is used as a part of both the double negative exponential distribution and the general queuing model in estimating the headways of the free vehicles as explained in section 4.6. In addition, the lognormal distribution is used as a part of the generalised queuing model in estimating the headways of the restrained vehicles.

In applying a selected headway model, random number [0-1] for each individual vehicle developed from the uniform distribution was used and set to be equal to the left hand side of the p.d.f. for the given distribution to calculate the headway value for each vehicle.

For motorway traffic, the shifted negative exponential distribution is applied as a default. This is because some tests have been conducted using the simulation model and the results show that there is no considerable effect in applying different headway distributions on the main traffic characteristics such as speed and flow.

For ramp traffic, because no data is available, the model estimates vehicle's arrivals based on the shifted negative exponential distribution using a shift value equal to 1.0.

#### *a. Modelling the negative exponential distribution*

According to the negative exponential distribution, the probability of having headway ( $h \leq t$ ) is:

$$f(t) = 1 - e^{-qt} \quad \text{Equation 5-1}$$

where  $q$  is the flow rate in veh/sec; Thus:

$$e^{-qt} = 1 - f(t) \quad \text{Equation 5-2}$$

Therefore;

$$-qt = \ln(1 - f(t)) \quad \text{Equation 5-3}$$

If the generating random number (Ran) equal to  $1-f(t)$  then:

$$-qt = \ln(\text{Ran}) \quad \text{Equation 5-4}$$

$$t = h = \frac{-\ln(\text{Ran})}{q} \quad \text{Equation 5-5}$$

b. Modelling the shifted negative exponential distribution

Similar to the procedure applied for negative exponential distribution, the following equation is used for the shifted negative exponential distribution.

$$h = \text{shift} - \left(\frac{1}{q} - \text{shift}\right) \ln(\text{Ran}) \quad \text{Equation 5-6}$$

c. Modelling the lognormal distribution

Walck (1996) suggested that the easiest way to deal with lognormal distribution is by using the exponential of the random numbers which are derived from the normal distribution. To generate such normal random numbers, the normal distribution table has been integrated as a subroutine in the simulation model to obtain the Z values based on the mean ( $\mu$ ) and the standard deviation ( $\sigma$ ) of the normal distribution.

The values of  $\mu$  and  $\sigma$  are calculated based on the mean ( $m$ ) and the standard deviation ( $s$ ) values of the lognormal distribution according to the equations presented in section 4.6

d. Modelling the double negative exponential distribution

This distribution assumes that vehicles in a traffic stream are either free or following (restrained). The headways of free vehicles follow the negative exponential distribution whereas the headways of restrained vehicles are obtained from Equation 5-7.

$$h = \emptyset - \ln(\text{Ran})(C - \emptyset) \quad \text{Equation 5-7}$$

where  $\emptyset$  is the proportion of constrained vehicles and C is the average headway of constrained vehicles as discussed in section 4.6.

The model generates two (new) random numbers ( $R_i$  and  $R_j$ ) for each vehicle derived from the random distribution in order to estimate the headway value for a given vehicle as shown in Figure 5-11. If  $R_i$  is less than  $\emptyset$  the vehicle is regarded as "restrained" and its headway will be obtained from Equation 5-7, otherwise the vehicle is regarded as "free" and its headway will be obtained from the negative distribution (i.e. using Equation 5-5).

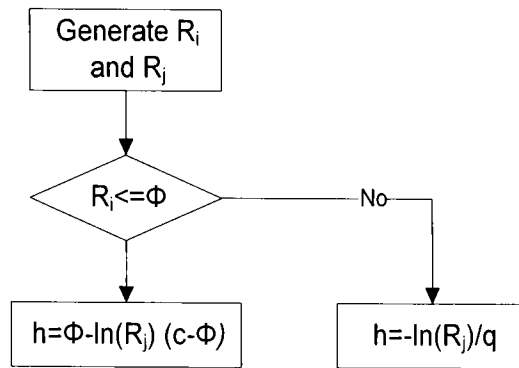

Figure 5-11 The double exponential distribution model

e. Modelling the generalised queuing distribution

Similar to the double exponential distribution, the generalised queuing model calculates the headways for free and restrained vehicles using different criteria as described in section 4.6. For free vehicles (the cases when  $R_i$  is equal or less than  $\Phi$  as shown in Figure 5-12), the negative exponential is used in estimating the free headway ( $h_1$ ) by using the random number  $R_j$  in Equation 5-5. The headway of restrained vehicles (the cases when  $R_i$  is higher than  $\Phi$  as shown in Figure 5-12) is assumed to be the sum of the free headway ( $h_1$ ) taken from the negative exponential distribution and the following headway ( $h_2$ ) taken from the lognormal distribution as suggested by Skabardonis (1981), Sultan (2000) and others.

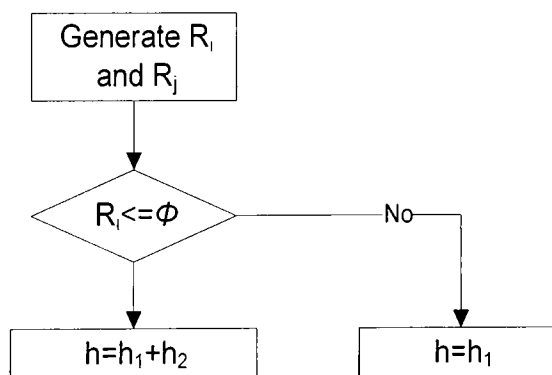

Figure 5-12 The generalised queuing model

### 5.7.3. Desired speed

Desired speed is the maximum speed that a driver may wish to use while travelling in a road section. According to Duncan (1976), the desired speed could be derived from the speed-flow relationship with a corresponding flow of less than 300 veh/hr.

For 3-lane motorway sections, Burrow (1974) suggested that for any mean motorway speed ( $u$ ), the desired speeds and the standard deviation ( $\sigma$ ) in the motorway lanes can be determined from Table 5-5.

Table 5-5 Mean speed and standard deviation for motorway lanes (Source: Burrow, 1974)

Lane No.	Mean speed	Standard deviation ( $\sigma$ )
1	$u-\Delta u$	$2\Delta u/3$
2	$u$	
3	$u+\Delta u$	

The speed difference between motorway lanes (i.e. " $\Delta u$ " in Table 5-5) was found to be 15 km/hr which suggests  $\sigma$  value of 10 km/hr (Skabardonis, 1981). This latter value was also used by many other studies (see for example, Sultan (2000) and Zheng (2003)). For the mean speed ( $u$ ), values of 97.5 and 118 km/hr were used by Skabardonis (1981) and Zheng (2003) respectively. These studies did not differ between the speeds of passenger cars and HGVs.

Yousif (1993) based on observed data from a motorway with 3 lanes suggested the values in Table 5-6 for means and standard deviations for cars and HGVs. The values in the table are close to those obtained from Table 5-5 if a  $u$  value of 109 km/hr is adopted. Therefore, in the absence of individual lane speeds, the values in Table 5-5 are used as defaults for the purpose of this study.

However, for HGVs, more recent observations from motorways taken from the IVD resources for both the M25 and the M42 suggest that the mean value of speed used for HGVs in lane 1 is about 86 km/hr. This is relatively higher than the 81 km/hr which was found by Yousif (1993) but with similar standard deviation. Therefore, a value of 86 km/hr is used as a default for mean speed of lane 1 (as shown between brackets in Table 5-5).

It is assumed that vehicles enter a section using their desired speeds which are derived from the normal distribution as suggested in all of the above referred studies. These speeds will be adjusted once they enter the section according to the car following rules.

Table 5-6 Mean speeds and standard deviations for 3-lane motorway (Source: Yousif, 1993)

Lane	Lane 1		Lane 2		Lane 3	
	Cars	HGVs	Cars	HGVs	Cars	HGVs
Speed (km/hr)	89	81 (86)	109	92	118	
Standard deviation (km/hr)	13.3	8.2	11.5	7.5	11.5	

## 5.8. Car following rules

### 5.8.1. Introduction

Car following rules calculate the acceleration/deceleration rates of successive vehicles with respect to their leaders and use these rates in updating their speeds and positions at the end of each scan time ( $\Delta t$ ) using Equations 5-8 and 5-9.

$$NV_C = V_C + a_C \Delta t \quad \text{Equation 5-8}$$

$$NP_C = P_C + V_C \Delta t + 0.5 a_C \Delta t^2 \quad \text{Equation 5-9}$$

where,

$a_C$  is the acceleration/deceleration rate of vehicle C ( $\text{m/sec}^2$ ).

$NV_C$  and  $NP_C$  are the updated speed ( $\text{m/sec}$ ) and position ( $\text{m}$ ) of vehicle C (at the end of the current scan time interval), and

$V_C$  and  $P_C$  are the current speed ( $\text{m/sec}$ ) and position ( $\text{m}$ ) of the vehicle C, respectively.

For the purpose of this study, safe car following rules have been developed mainly based on CARSIM's assumptions (Benekohal, 1986) with some modifications. The developed rules for car following mainly estimate three acceleration/deceleration rates. These rates are required to enable a vehicle to reach its desired speed ( $ac_1$ ), maintain its desired headway ( $ac_2$ ) and provide a safe following distance ( $ac_3$ ). The acceleration rate ( $ac_4$ ) is also used for vehicles which are moving from a stationary condition. In addition, normal and maximum rates are also considered as the boundary limits (i.e.  $ac_5$ ,  $ac_6$ ,  $ac_7$  and  $ac_8$  as discussed later).

The derivation procedures of  $ac_1$ ,  $ac_2$  and  $ac_3$  are similar to those used by Benekohal (1986). However, a DRT value is suggested in this study and used in the calculation of these rates rather than  $\Delta t$ . This is due to the fact that applying relatively small  $\Delta t$  values (e.g. 0.1 to 0.4 seconds) or having relatively high  $\Delta t$  values (e.g. 1 to 2 seconds) would significantly influence the results. This finding is supported by Laval and Leclercq (2008) when they considered updating the system for the lane changing process.

### 5.8.2. Types of acceleration rates

#### 1. Acceleration required to reach the desired speed ( $ac_1$ )

Equation 5-10 is used to calculate the acceleration rate for a vehicle travelling with a speed lower than its desired speed (or the speed influenced by the posted speed limit).

$$a_{c_1} = \frac{DV_C - V_C}{DRT_c} \quad \text{Equation 5-10}$$

where  $DV_C$  and  $DRT_c$  is the desired speed and the driver reaction time of the vehicle C, respectively.

The use of this rate is necessary in order to prevent a vehicle from exceeding its desired speed when the other accelerations ( $a_{c_2}$  and  $a_{c_3}$  described below) provide positive values even in situations where a vehicle has already reached or approached its desired speed. Another reason for the use of this rate is to enable a vehicle to decelerate in order to match the posted speed limit. It should be noted here that, in some cases, Equation 5-10 provides high acceleration rates and therefore will not be used as the governing value when calculating the required acceleration rate (see section 5.8.3 for further details).

## 2. Acceleration required to keep the desired spacing ( $a_{c_2}$ )

Equations 5-11 to 5-15 calculate  $a_{c_2}$  to enable the follower (after a period equal to his/her DRT) to maintain a desired spacing equal to his/her reaction time (DRT).

$$NP_L - NP_C \geq NV_C DRT_c + S_{\min} \quad \text{Equation 5-11}$$

where,

$NP_L$  is the anticipated new position of the leader (m), and  $S_{\min}$  is the minimum separation between vehicles at stopping conditions (buf) plus leading vehicle's length (m).

$$NP_C = P_C + V_C DRT_c + 0.5 a_{c_2} DRT_c^2 \quad \text{Equation 5-12}$$

$$NV_C = V_C + a_{c_2} DRT_c \quad \text{Equation 5-13}$$

By substituting Equations 5-12 and 5-13 in Equation 5-11:

$$NP_L - (P_C + V_C DRT_c + 0.5 a_{c_2} DRT_c^2) \geq (V_C + a_{c_2} DRT_c) DRT_c + S_{\min} \quad \text{Equation 5-14}$$

And therefore,

$$a_{c_2} = \frac{NP_L - P_C - 2 V_C DRT_c - S_{\min}}{1.5 DRT_c^2} \quad \text{Equation 5-15}$$

For the follower to anticipate the new projected position of the leader ( $NP_L$ ), Benekohal (1986) and Hidas (1996) assumed that the follower has information about the acceleration/deceleration rate which will be applied by the leader during the current  $\Delta t$ . This assumption is likely to provide unrealistic behaviour in cases involving close following behaviour. Therefore, the model estimates the projected position ( $NP_L$ ) based on



the anticipated position of the leader assuming no acceleration/deceleration rate was applied within DRT using Equation 5-16.

$$NP_L = P_L + V_L DRTc \quad \text{Equation 5-16}$$

where  $P_L$  and  $V_L$  are the current position (m) and speed (m/sec) of the leader.

The “buf” value of 3m is used for motorway traffic as suggested by Zia (1992). For ramp traffic, and because real data shows closer spacings between vehicles stopped at traffic signals, a lower value of 1.5m is used.

### 3. Acceleration for non collision criteria ( $ac_3$ )

$ac_3$  in Equation 5-17 (which is modified from Benekohal (1986)) is derived to enable the follower, after a period equal to his/her DRT, to decelerate safely even if the leader makes a sudden stop by applying a maximum emergency deceleration. The  $ac_3$  value is calculated using an iterative process starting from a maximum acceleration to a maximum deceleration with an incremental value of  $-0.05 \text{ m/sec}^2$ .

$$NP_L + \frac{V_L^2}{2 md_L} \geq P_C + V_C DRTc + 0.5 ac_3 DRTc^2 + \frac{(V_C + ac_3 DRTc)^2}{2 md_C} + S_{\min} \quad \text{Equation 5-17}$$

where,

$md_C$  is the maximum deceleration rate for the follower, and  
 $md_L$  is the maximum deceleration rate for the leader.

### 4. Acceleration from a stationary condition ( $ac_4$ )

In the situation of stop-and-go conditions, drivers usually take a period of time called “move-up delay” to start their movement after stopping. According to Yousif (1993), move-up delay varies between 0.6-4 seconds. This also has been tested in this study using real traffic data from the M60 for passenger cars only. Figure 5-13 suggests that 50 percent of passenger car drivers have a move-up delay of about 1.8 sec which is similar to that reported by Yousif (1993). In the model, and as applied by Benekohal (1986) and Yousif (1993), it is assumed that 20% of drivers with a lower reaction time have a move-up delay of 1.2 seconds while the value of 2.0 seconds is used for other groups with a higher reaction time. The applied acceleration rate after the move-up delay is assumed to be 2 km/hr/sec for cars and 1 km/hr/sec for HGVs (Yousif, 1993).

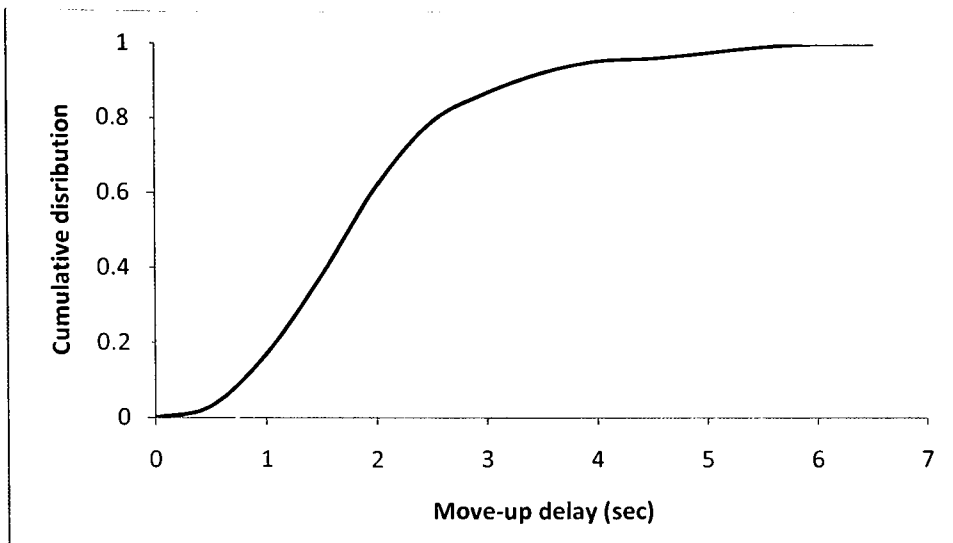

Figure 5-13 Cumulative distribution for move-up delay based on data from the M60

### 5.8.3. Selection criteria for the acceleration rate

At every  $\Delta t$ , a unique value for the acceleration/deceleration rate ( $a_c$ ) is selected and is used in updating speeds and positions for each vehicle using Equations 5-8 and 5-9. The criterion for selecting this value is shown in the flowchart presented in Figure 5-14. The obtained rate (i.e.  $a_c$ ) from the minimum of  $a_{c1}$ ,  $a_{c2}$  and  $a_{c3}$  (see equation 5-18) should be compared with the normal and maximum acceleration rates ( $a_{c5}$  and  $a_{c6}$ ) and also with the normal and maximum deceleration rates ( $a_{c7}$  and  $a_{c8}$ ) as described in section 5.6.3.

$$a_c = \min(a_{c1}, a_{c2}, a_{c3}) \quad \text{Equation 5-18}$$

The selected unique value for the acceleration/deceleration rate is obtained as follows:

- In situations where the value calculated from Equation 5-18 is positive (i.e. acceleration is required), Equation 5-19 is used. In normal driving conditions when no sharp acceleration rate is required, the value obtained from Equation 5-18 should not exceed the normal acceleration rate ( $a_{c5}$ ). The maximum acceleration rate ( $a_{c6}$ ) is used as a limit in situations where a vehicle requires the application of a sharp acceleration rate (e.g. when a vehicle starts its movement after being stopped at traffic signals (Van As (1979) and Zia (1992)) or when a vehicle is required to apply an acceleration rate in order to merge from the auxiliary lane).

$$a_c = \begin{cases} \min(a_{c1}, a_{c2}, a_{c3}, a_{c6}) & \text{if sharp acceleration is required} \\ \min(a_{c1}, a_{c2}, a_{c3}, a_{c5}) & \text{else} \end{cases} \quad \text{Equation 5-19}$$

- In situations where the calculated rate from Equation 5-18 is negative (i.e. deceleration is required), the selected deceleration rate is calculated as follows. If the

speed of the leader ( $V_L$ ) is higher than the speed of the follower ( $V_C$ ) by a certain value (i.e. 5 km/hr according to Sayer *et al.* (2003) and Zhang and Bham (2007)) and if the minimum separation (buf) between the two vehicles is available, the follower will not apply any deceleration rate (i.e.  $a_c=0$ ). If  $V_L$  is not significantly higher than  $V_C$  or when the minimum separation distance is not available, the normal deceleration rate ( $ac_7$ ) is used as a limit in situations when the safe acceleration rate ( $ac_3$ ) is higher than  $ac_2$  and the maximum deceleration rate ( $ac_8$ ) is used in other cases (see Equation 5-20).

$$a_c = \begin{cases} \min[0, \max(ac_3, ac_7)] & \text{if } ac_3 \geq ac_2 \\ \min[0, \max(ac_3, ac_8)] & \text{else} \end{cases} \quad \text{Equation 5-20}$$

- In situations of stop-and-go conditions and as a separate case, the acceleration of the follower should not exceed  $ac_4$  as described above.

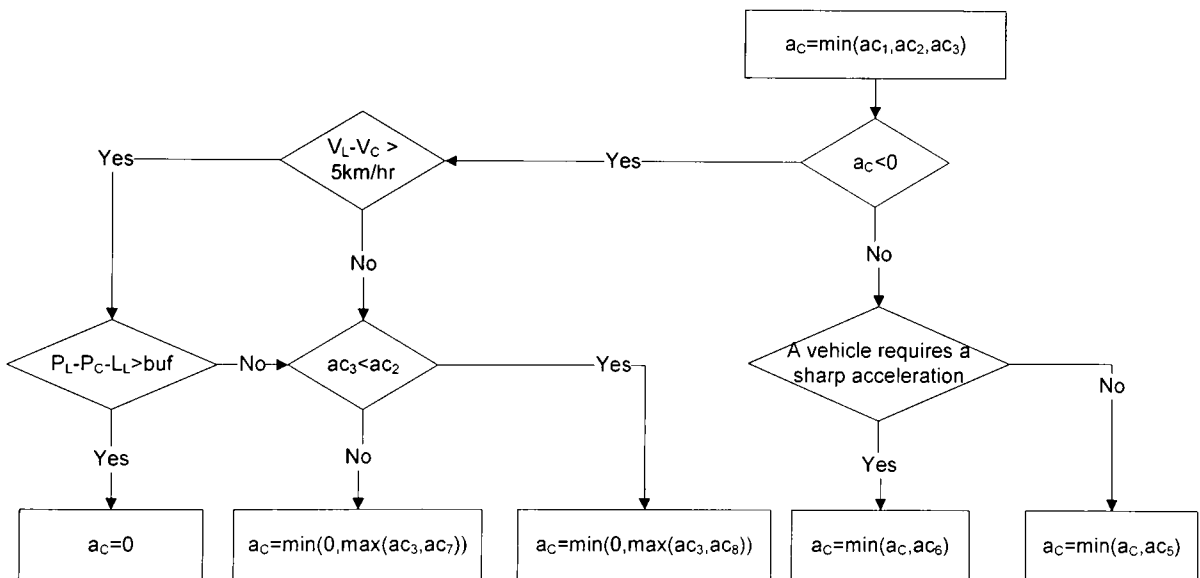

Figure 5-14 The general structure of the car following rules

**5.8.4. Comparison with CARSIM**

As mentioned earlier, the car following rules in this study were developed using similar logic to that for CARSIM with some changes in order to enhance some existing limitations in CARSIM. Specifically, CARSIM assumes that drivers have information about the updated speeds and positions of their leading vehicles (i.e. speeds and positions at the next time interval). This assumption results in unrealistic behaviour for CARSIM especially in representing drivers’ reaction time. For example, Figure 5-15 is taken from the work by Aycin and Benekohal (2001) when they studied the behaviour of CARSIM model. The figure shows that 29 follower vehicles start their deceleration at the same time as the leading vehicle started its deceleration rate.

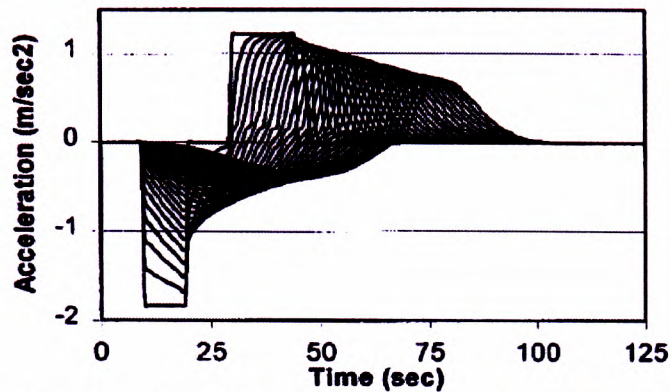
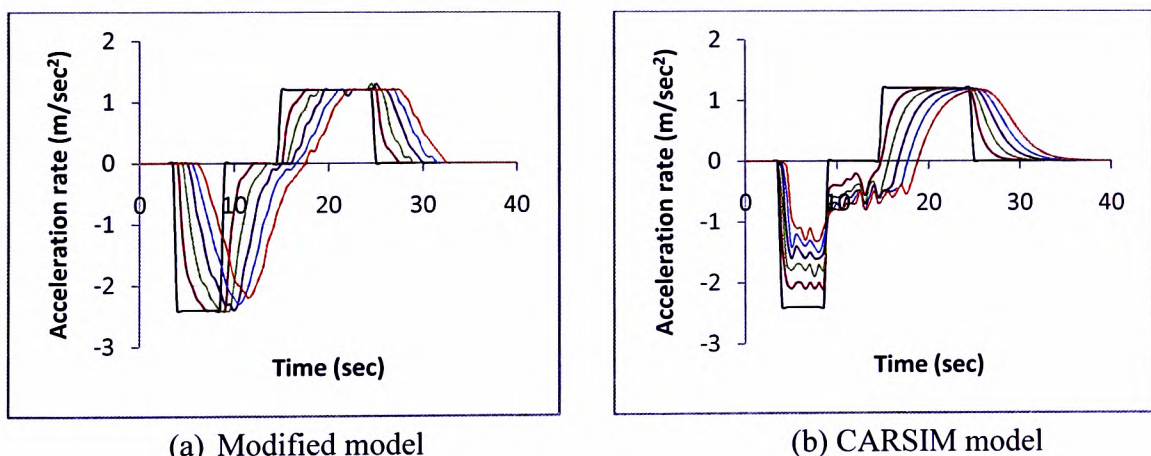

Figure 5-15 Acceleration of vehicles in platoon using CARSIM (Source: Aycin and Benekohal, 2001)

Figure 5-16 compares the behaviour of the developed model with that of CARSIM assuming that there is a group of 6 vehicles moving in one lane where the first vehicle in the group applied a normal deceleration rate followed by a constant speed followed by a normal acceleration rate. The figure shows how the applied modifications enhanced the ability of the model in representing drivers' reaction times when there are clear time shifts in the reaction of the follower vehicles with respect to the deceleration rates applied by their leaders.



(a) Modified model

(b) CARSIM model

Figure 5-16 Acceleration rates for vehicles in the platoon

### 5.9. Lane changing rules

Lane changing (LC) rules describe the lateral movements of vehicles from a lane to another. In this study, two main types of LC are considered, namely mandatory and discretionary LC. The mandatory LC happens in cases where drivers are required to change lanes due to, for example, merging from the ramp (auxiliary lane) onto the motorway as will be explained in more detail in this section.

### 5.9.1. Discretionary lane changing (DLC) rules

As discussed in section 2.3.1, DLC represents the cases where drivers are not necessarily required to change their lanes. In such cases, the main reasons for drivers to make lane changes are to enhance their speeds (Sultan and McDonald, 2001) or it is a situation where they wish to return their original lanes following an overtaking process (Ferrari, 1989).

The developed LC algorithm considered the UK motorway regulations based on the recommendations of the British Highway Code (2010) where drivers are not allowed to undertake and where HGVs are banned from using the offside lane for motorways with 3 or more lanes.

The general structure of the developed rules for DLC is shown in Figure 5-17 which is similar to other models that consider the desirability and feasibility of undertaking a lane change (see section 2.3.2). However, the specific details of the desirability and feasibility assumptions used in such models may differ from one another as discussed in section 2.3.2.

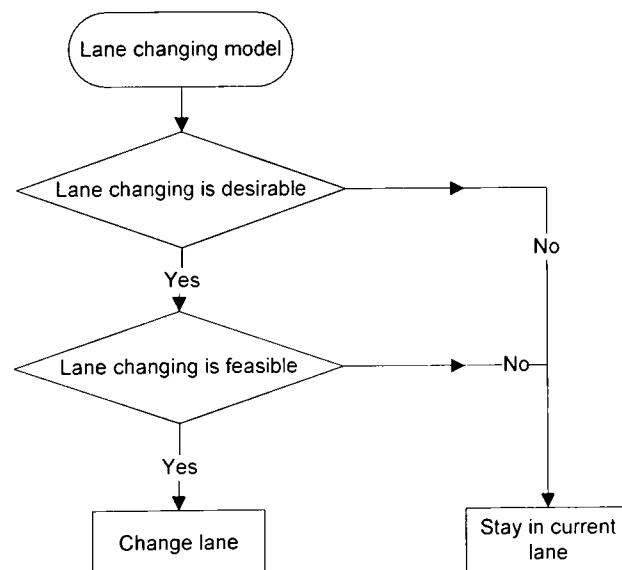

Figure 5-17 The general structure of DLC

Figure 5-18 shows the surrounding traffic that directly affects the decision made by vehicle C regarding the desirability and feasibility of LC as discussed below. However, it is also assumed that a driver looks ahead for a maximum of 250m to check whether or not there is an incident in the current or the target lane.

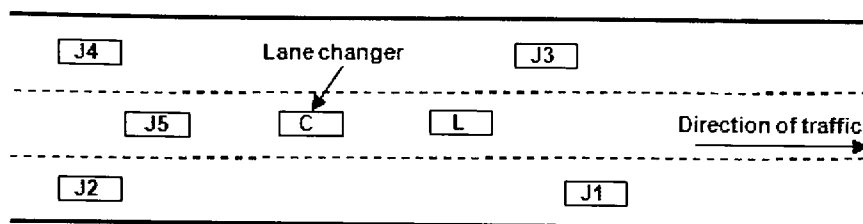

Figure 5-18 Surrounding traffic that affects the LC of vehicle C

### 5.9.1.1. The desirability of LC

#### a. *Toward right lanes*

In this study, the desirability of having a lane change toward right lanes is based on satisfying one of the following rules:

- If the desired speed of C is higher than that of L by a magnitude “R” (which is equal to  $1040/\text{desired speed}$  as described in section 2.3.2).
- If the speed of C is lower than its desired speed by a value of “R” and the car following rules do not allow an increase in speed.

#### b. *Toward left lanes*

The desirability of having a lane change toward left lanes is based on satisfying one of these conditions:

- The C vehicle prefers to change to a slower lane (i.e. left lane) if its speed is less than that of its follower (J5 in Figure 5-18) by a value of R. This is applicable only when the speed of C is equal or close to its desired speed.
- A proportion of drivers (PD) prefer to retain their original lanes after overtaking a slower vehicle in the traffic stream (as suggested by Yousif (1993)). This is not applied for drivers who are using the offside lane for overtaking as in such a case it is assumed that all drivers wish to retain their original lane. The PD parameter would be obtained from the calibration and validation processes. However, this condition is mainly applicable for cases with free to moderate flow rates (i.e. traffic density is relatively low).

### 5.9.1.2. The feasibility of LC

#### a. *Toward right lanes*

The feasibility of executing a lane change, as shown in Figure 5-19, depends on whether the lane change is beneficial and on the availability of sufficient lead and lag gaps. If J1 is within a distance (D) (as shown in Figure 5-20) and the speed of J1 not higher than that for L by a value of “R”, the LC process is regarded as unfeasible and therefore LC is

aborted. The value of the D parameter would be estimated from the calibration process of the LC rules. If the speed of J1 is higher by a value of “R”, other checks for available gaps in the new lane (i.e. minimum lead and lag gaps as in Equations 5-21 and 5-22) are made before executing a lane change. The effect of J1 on the LC process is ignored if the clear spacing between C and J1 vehicles is higher than the D value.

$$g_{\min}^{\text{lead}} = \alpha \text{DRTc} V_C + \text{Max} \left[ 0, \left( \frac{V_C^2}{2 \text{md}_C} - \frac{V_{J1}^2}{2 \text{md}_{J1}} \right) \right] + \text{buf} \quad \text{Equation 5-21}$$

$$g_{\min}^{\text{lag}} = \alpha \text{DRTc} V_{J2} + \text{Max} \left[ 0, \left( \frac{V_{J2}^2}{2 \text{md}_{J2}} - \frac{V_C^2}{2 \text{md}_C} \right) \right] + \text{buf} \quad \text{Equation 5-22}$$

where,

$\alpha$  is a calibration parameter.

$\text{md}_C$ ,  $\text{md}_{J1}$  and  $\text{md}_{J2}$  are the maximum deceleration rates of the lane changer C, the new leader J1 and the new follower J2 vehicles, respectively, and

$V_C$ ,  $V_{J1}$  and  $V_{J2}$  are the speeds of the C, J1 and J2 vehicles, respectively.

A value of  $\alpha=1$  is used here for normal LC and reduced to be 0.75 in congestion situations (e.g. when the local traffic density exceeds a value of 37 km/hr/lane). Different values for the  $\alpha$  parameter are used in cases of mandatory LC (i.e. merging from the ramp) as will be shown later.

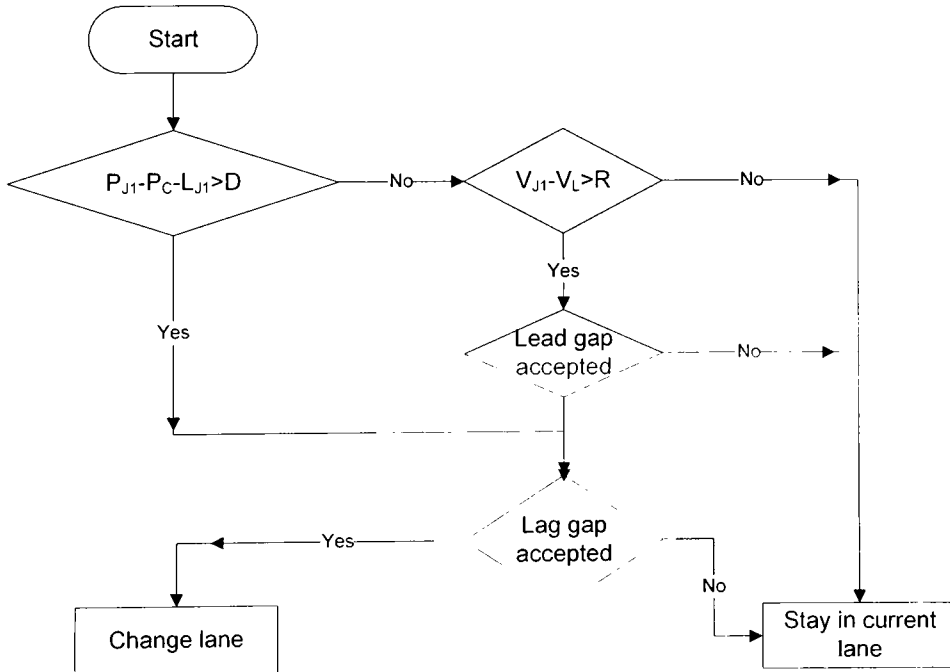

Figure 5-19 Feasibility of LC towards right lanes

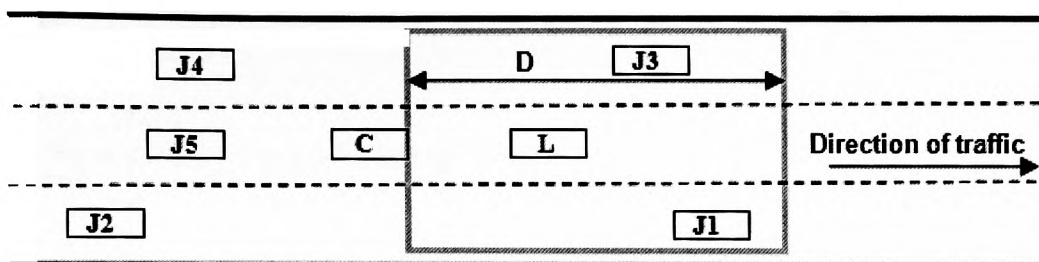

Figure 5-20 Illustration for the D parameter

*b. Towards left lanes*

The feasibility of executing a lane change toward left lanes is based on the following rules (see Figure 5-21):

- If J3 is within a distance D (as shown in Figure 5-20) and the speed of J3 is less than that for C, LC is regarded as unfeasible. If the speed of J3 is higher or equal than that for C, other checks for available gaps in the new lane are made before executing a lane change (i.e. minimum lead and lag gaps as in Equations 5-21 and 5-22).
- If the spacing between C and J3 is higher than the D value and if C is not affecting J5, a projection for the C position with J3 is made in order to ensure that C will not decelerate within a short period (threshold) of 15 seconds. The 15 seconds' threshold is selected based on findings by Yousif (1993). However, this condition is unlikely to be effective unless the speed of J3 is significantly lower than the speed of C.
- In a case where there is no significant difference between the speeds of C and J3, the effect of J3 on the LC process is ignored if the clear spacing between C and J3 is higher than an assumed distance of 150m. This is to reduce the simulation time since the calculations of the LC process will be not influenced by J3 if such a higher distance is available.
- In exceptional cases where J4 is travelling faster than C, LC is regarded as unfeasible if difference in speeds between C and J4 is higher than R.



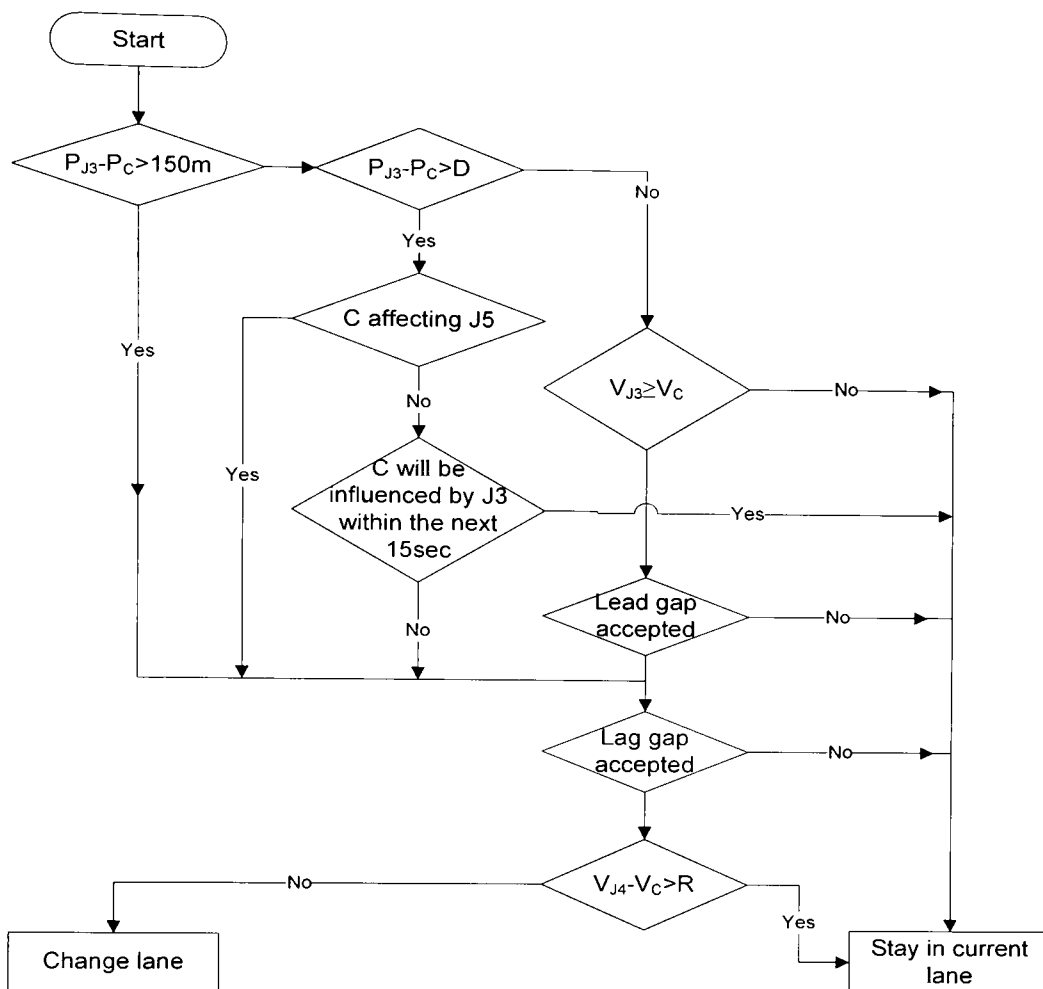

Figure 5-21 Feasibility of LC toward left lanes

### 5.9.1.3. Additional rules

There are also some general rules which have been applied for LC. These rules are:

- During LC manoeuvring, the acceleration/deceleration rate that is applied by the lane changer (C) is the minimum of A1 with respect to current leader (L) in the current lane and A2 with respect to the new leader (J1) in the new lane (see Figure 5-22). The calculations for A1 are applied based on very low value of DRT of 0.2 second in order to provide a chance for C to complete its manoeuvring smoothly and without conflicting with the current leader. Consequently, the acceleration/deceleration rate of the new follower (J2) will be the minimum of A3 with respect to its current leader (J1) and A4 with respect to C. It should be noted that each of A1, A2, A3 and A4 are obtained from the car following rules that described in section 5.7.
- During the manoeuvring time, the drivers of C and J2 are assumed to be alerted (i.e. the drivers' reaction time is reduced as discussed in section 5.6.1). This will only affect the calculations of A2 and A4.

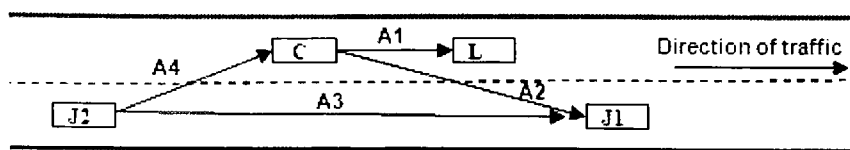

Figure 5-22 Acceleration rates during LC manoeuvring

- The average manoeuvring time and standard deviation for passenger cars and HGVs that are used are shown in Table 5-7 based on real traffic data, as presented in section 4.7.2.

Table 5-7 Average and standard deviation (sec) for manoeuvring time for LC

Vehicle type	Mean	$\sigma$	Minimum	Maximum
Passenger cars	2.57	0.6	1.0	4.0
HGVs	4.0	0.7	2.5	5.0

### 5.9.2. Merging (mandatory) rules

This section deals with mandatory LC which applies to merging traffic. Figure 5-23 provides the main model structure for the possible interactions between motorway and ramp traffic. The assumed interactions for the process before merging occurs have some similarity with those reported by, for example, Zheng (2003) and Sarvi and Kuwahara (2007), as discussed in section 2.3.3.

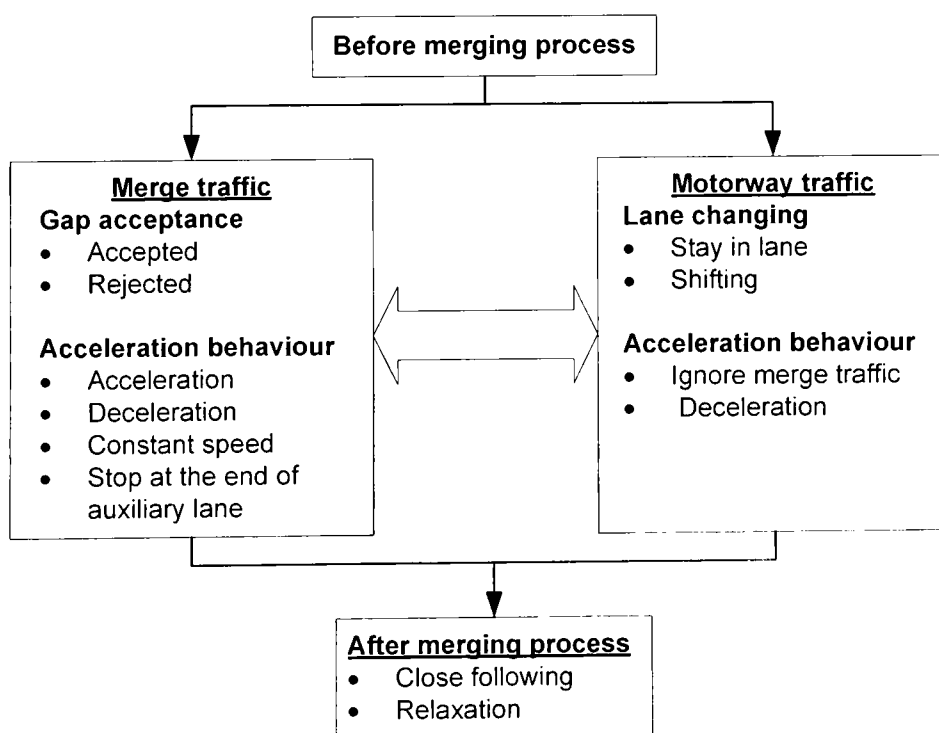

Figure 5-23 Structure of drivers' behaviour within a merge section

### 5.9.2.1. Merging traffic behaviour

This section describes the behaviour of traffic when merging from a slip road. It should be noted here that no explicit rules have been used in the model for merging behaviour in the presence of RM signals. This is due to lack of reliable data showing the effect of RM signals on motorway drivers' behaviour. However, in the model, the presence of RM signals affects the speed of merging vehicles which may affect the merging process (e.g. acceleration/deceleration rates and gap selection behaviour).

#### *a. Acceleration/deceleration behaviour*

The merging process consists of many complicated tasks including acceleration and/or deceleration and finally merging within the motorway traffic (Michaels and Fazio, 1989). In the model, drivers on the slip-road (on-ramp) are assumed to accelerate/decelerate in order to match the speed of the nearest lane of the motorway once they reach the nose area as shown in Figure 5-24 (Hounsell and McDonald, 1992 and Zheng, 2003). When drivers reach the auxiliary lane (or just before that by a short distance) they will start to adjust their speeds and positions with respect to the selected target gap (Zheng, 2003 and Wang, 2006). The following cases consider merging behaviour based on the size of the lead and lag gaps (see flowchart in Figure 5-25) compared with the minimum accepted gaps.

- (Case 1) Both lead and lag gaps are accepted (e.g. Figure 5-24-a). In this case, a driver will directly start his/her manoeuvring and merge with the motorway traffic.
- (Case 2) The lead gap is accepted whereas the lag is rejected (see Figure 5-24-b). In this case, obtaining an unsuitable reaction from the merger (C) might not allow this vehicle to merge using the selected gap especially if there is no cooperative or yielding behaviour from J2. For example, assume the case of both C and J2 having the same running speed; in this case vehicle C has no chance to merge if vehicle J2 does not slow down and/or if vehicle C does not react properly. A possible reaction of the merger (C) is to accelerate in order to accept the lag gap as well. However, this process is not a straightforward one because undertaking such acceleration may cause the lead gap to be rejected as a result of increases in the difference in relative speed and/or decreases in the clear spacing between C and J1. In the model, such adjustments (i.e. acceleration) will only be applied after checking how this behaviour will help the merger in accepting the projected lead and lag gaps without overshooting the end of the auxiliary lane (EOAL) and without conflicting with the current leader (L, if found) on the auxiliary lane. The flowchart shown in Figure 5-26 describes the process of estimating the projected

positions of vehicles C, L, J1 and J2. Here an assumption is made that C applies a maximum acceleration rate whereas L and J1 keep their constant speeds. If the driver of J2 is cooperative, the position and speed of J2 are estimated assuming that J2 applies a normal deceleration rate.

- (Case 3) The lead gap is rejected whereas the lag gap is accepted (see Figure 5-24-c). Additionally for this case, obtaining an unsuitable reaction from the merger may not help this vehicle to merge. For example, assume the case of both C and J1 vehicles having similar running speeds; in this case vehicle C has no chance to merge without slowing down (i.e. applying deceleration). Again, this process is not a straightforward one because undertaking such a deceleration may cause the lag gap to be rejected as a result of increasing the difference in relative speed and/or decreasing the clear spacing between C and J2. The merging rules will enable vehicles to apply such deceleration rates only if this helps in accepting both the lead and lag gaps to avoid overshooting the EOAL using a similar algorithm to that in Figure 5-26.
- (Case 4) Both lead and lag gaps are rejected (see Figure 5-24-d). In this case, vehicle C does not have a good chance of merging within the first gap without receiving a cooperative or yielding behaviour from J2. However, if C receives such cooperative or yielding behaviour, then it needs to adjust its speed and position similar to that discussed in Case 3 above. If J1 changes its lane (for some reason) then C could accelerate in order to increase its lag gap (as discussed in Case 2). If none of the above happens, C has to consider either the previous gap or the next available one. If the merger has no leader in the auxiliary lane and there is no suitable gap in which to merge, the model will then apply car-following rules by assuming that there is an imaginary leader stopping at the EOAL. This latter assumption is necessary to stop the merger and to prevent C from overshooting the EOAL.

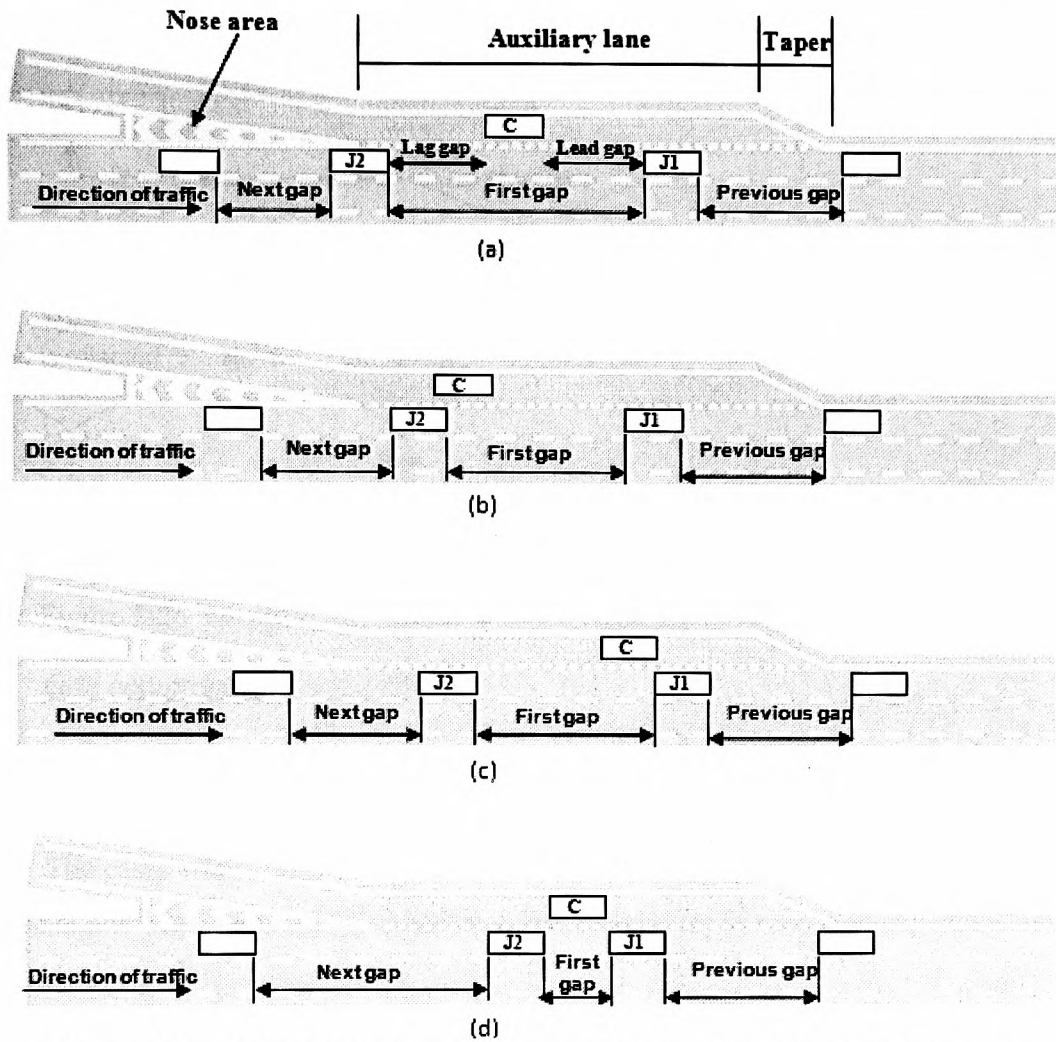

Figure 5-24 Drivers' situations with respect to the size of lead and lag gaps

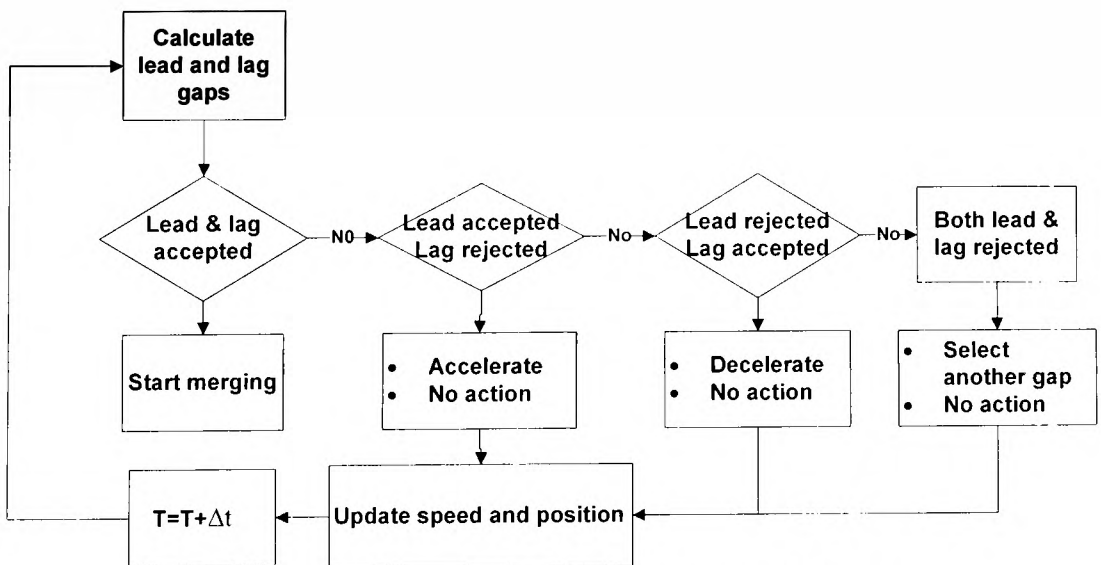

Figure 5-25 Merger actions with respect to available gaps

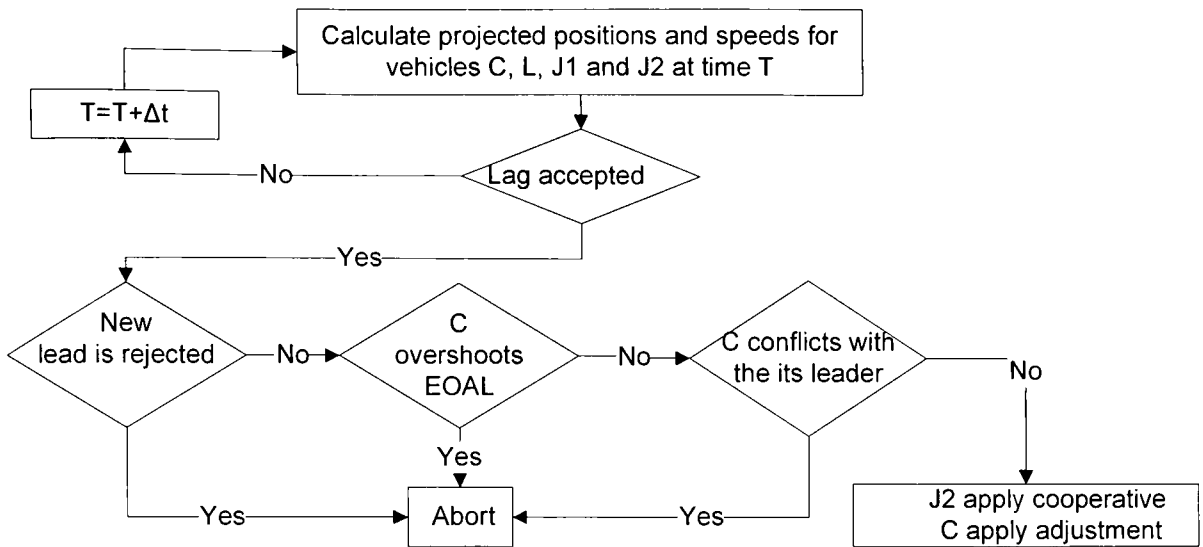

Figure 5-26 Merging interaction – projected positions and speeds of vehicles

*b. Gap acceptance for merging*

The following points are considered in selecting the gap acceptance model for merge traffic:

- The cases where drivers have to stop at EOAL should be minimised in situations of normal and high flow traffic conditions (not congested) based on observations for UK motorways.
- The selected lead and lag gaps should be safe for merger, lead and lag vehicles.
- The variability among drivers should be considered (i.e. the size of accepted and lag gaps should not be the same for all drivers).
- Unrealistic behaviour should be avoided when the gap acceptance and car following rules are integrated.

Yousif (1993), Liu *et al.* (1995), Hidas (2005) and Wang (2006) stated that the accepted gaps for merge locations are usually lower than those used in DCL. Also, Ackroyd and Madden (1973), Zia (1992) and Zheng (2003) suggested that the size of the lead gap is significantly lower than that of the lag. Equations 5-21 and 5-22 that were used for DLC are used here with different values for the “ $\alpha$ ” parameter and without using the “buf” term. The calibration process reveals that values of 0.3 and 0.5 are suitable for the “ $\alpha$ ” parameter in estimating minimum lead and lag gaps, respectively. The “ $\alpha$ ” parameter is reduced further to a value of 0.2 second in situations where the vehicle receives cooperative behaviour or when a vehicle makes a forced merging after failing to get suitable gaps to merge. This is consistent with the findings by Choudhury (2007) when she suggested that the size of the critical (minimum) gaps should be reduced in cases of cooperative and force

merging. For the cases where the speed of J1 is already higher than that for C, a minimum lead gap of 1.0m is used as a default value. This latter value (i.e. 1.0 m) is also used as a minimum lag gap in cases where the speed of C is already higher than that for J2.

### 5.9.2.2. Motorway traffic behaviour

Real traffic data from the M60 J10, the M60 J12, the M56 J2, the M56 J4 and other sites suggest that more than 95% of drivers accept the first available gap when merging. Studies by Kou and Machemehl (1997b), Zheng (2003) and Wang (2006) have reported similar findings. This could either be explained by the cooperative behaviour of motorway traffic and/or by the “aggressive” behaviour of merge traffic.

Observations (see section 4.8) suggested that the cooperative and yielding behaviour, mentioned earlier, amongst drivers are pronounced for all traffic conditions (i.e. free to congested situations). These two kinds of behaviour were considered in the development of the model. If a driver anticipates that he/she has to reduce his/her speed by a value exceeding “R” (as mentioned before) due to another driver merging from the ramp, then this driver (in the model) is assigned to considering undertaking yielding behaviour (i.e. shifting to other adjacent offside lanes). The feasibility of undertaking such yielding will be based on the availability of sufficient gaps in the new lane. If the lead or lag gaps in the adjacent lane is rejected, then the driver may consider slowing down (applying deceleration) if such a reaction will help the merger (using a similar procedure to that described in Figure 5-26). The model assumes that the applied deceleration rate for cooperative behaviour is estimated from the car following rules with respect to the merger and should not be too sharp (i.e. not exceeding the normal rate of  $-3 \text{ m/sec}^2$ ).

### 5.9.2.3. Drivers’ behaviour during and after the merging process

During the merging process, both C and J2 are assumed to keep “close following” behaviour which is assumed to continue for a short period of a maximum of 20 seconds (see the discussion in section 4.5.3). After this period (the relaxation period), drivers will recover their desired headways according to the car following rules (Smith, 1985, Cohen, 2004). The “close following” behaviour within the 20 seconds’ period does not mean that drivers have to accelerate in order to get closer to their leaders, but it means that the merger and its follower will accept lower separation distance (i.e. clear spacing values) for a specific period of time.

## 5.10. Modelling of ramp metering (RM)

Modelling of RM requires applying similar systems to those existing in real sites. Similar loop detectors to those illustrated in section 3.6.2 were included in the model for both motorway and slip roads. These detectors estimate the average speed, flow and occupancy at each selected time interval.

Some of the RM algorithms presented in section 3.6.3 are integrated within the developed model. These include the D-C, ALINIEA, ANCONA, and RMPS algorithms. In addition, some new algorithms have been developed and integrated with the simulation model aiming to enhance the results obtained from the RM system as will be discussed later in chapter 8.

### 5.10.1. Turn on/off criteria

Most of the existing methods mentioned above (excluding the ANCONA algorithm) use occupancy on the main motorway to give an indication of the flow conditions (i.e. free, normal and congested). In this study and for the D-C, ALINEA and RMPS algorithms, it is assumed that RM will operate only if the current downstream occupancy value ( $O_{out}$ ) exceeds the selected threshold ( $O_{des}$  for the ALINEA & RMPS algorithms and  $O_{cr}$  for the D-C algorithm). Once RM is operated, traffic signals will not be turned off until the occupancy value is reduced below a pre-selected minimum value ( $O_{min}$ ). A value of 15% has been used at many UK RM sites for the latter parameter (i.e.  $O_{min}$ ) and, therefore, this value is applied in the model. The selection of  $O_{des}$  depends on many factors (as will be discussed later) and, therefore, it will be obtained from the calibration process for each specific algorithm used.

Additionally, the decision to turn off the signals is subject to the disappearance of queues created upstream by traffic signals on slip roads. If such queues continue to exist, the metering rates will be increased in order to discharge the queue before turning off the signals.

For the ANCONA algorithm, RM would only be operated if the speed obtained from the upstream detectors is decreased below a "congestion indicator, Sp1" and the turn off of the signals would only occur if the upstream speed is increased and became higher than the Sp1 and lasted for a specific period of time.



### 5.10.2. Calculation of the metering rate

The metering rate applied in the calculations of signal timings is the minimum of the metering rate obtained from the RM logic of the selected algorithm (see section 3.6.3) and that calculated for the applied queue override strategy (QOS, as discussed in section 3.6.5). The application of the QOS is to prevent ramp queues created upstream of the signal from spilling back upstream to other networks. Many QOSs have been integrated and tested in the developed simulation as will be explained in chapter 8.

### 5.10.3. Calculation of signal timings

The design procedure for traffic signal timings for RM sites is not as complicated as in the case of normal junctions in urban areas where the designer should consider the other conflicting movements from other directions and also the presence of pedestrians crossing at junctions (see for example Salter and Hounsell (1996) for the design procedure of traffic signals for normal junctions). Generally, traffic lights in the UK are operated using the following timings (EURAMP, 2007):

- Green period (G)
- Stopping amber period (A), usually applied as 3 seconds.
- Red period
- Red-amber period (or referred to as “starting amber” by Maxwell and York (2005) and Heydecker *et al.* (2007)).

The starting amber period, usually 2 seconds before operating the green phase, is used to alert drivers about the forthcoming green period. However, according to Maxwell and York (2005), this period is mainly applied in the Scandinavian and northern European countries including the UK and not used in most countries outside Europe.

The cycle length in a RM system is used as either fixed or variable (EURAMP, 2007). For the fixed cycle length, the green time (G) is calculated as follows:

$$G = Sd + Cl \frac{qr_L}{S} \quad \text{Equation 5-23}$$

where,

Cl is the cycle length (sec).

$qr_L$  is the metering rate per lane obtained from a RM algorithm,

S is the saturation flow rate which is the maximum flow rate that could cross the stop line if a signal was to stay green for an entire hour, and

Sd is the start up delay which was reported to be about 1.75 seconds from the start of the starting amber period (Maxwell and York, 2005).

The variable cycle length is calculated using the following equation:

$$Cl = 3600 \frac{N}{qr_L} \quad \text{Equation 5-24}$$

where N is the number of vehicles per lane that would be released during the cycle.

The calculated green time for the variable cycle length time should be enough to allow for N vehicles to be released. This is done by taking into consideration the delay that happens at the start of each green time (starting delay, Sd) and the average time headway (h') between the successive vehicles which cross the stop line during green period using Equation 5-25:

$$G = Sd + h' N \quad \text{Equation 5-25}$$

The headways of the individual vehicles crossing the stop line are varying based on the position of the vehicles in the ramp queue. Real observations from traffic signals' sites suggested average time headway (h') of 2 seconds and therefore this value is used in the model.

For both the fixed and variable cycles, the starting amber period of 2 seconds is applied in the UK traffic signal system prior to operating the green signal. These 2 seconds are regarded to be equivalent to the starting delay in the developed model. The red period is calculated as follows:

$$\text{Red} = Cl - G - A \quad \text{Equation 5-26}$$

#### 5.10.4. Modelling of drivers' compliance with signal timings

In the model, and as real observations showed, it is assumed that drivers would stop during the red period. During the amber period (stopping amber after green phase), it was reported by Papacostas (2005) that for three or four legs' intersections (i.e. not for RM sites), drivers will stop if there is a chance to do that by applying normal deceleration rates (nd). Drivers' behaviour during amber periods is usually associated with reaching a so-called "dilemma zone" section. A dilemma zone is defined as an area approaching the stop line within which a driver, before operating red signals, may not be able to stop safely and also may not be able to clear the intersection at a legal speed limit (Papacostas, 2005). Therefore, most related studies suggested that drivers, during the stopping amber period, would only stop in situations where the remaining distance to the stop line is equal or higher than the stopping distance (S.D) obtained from Equation 5-27.

$$S. D = V_C DRTc \frac{V_C^2}{2 nd} \quad \text{Equation 5-27}$$

The above discussion may be related only to drivers who are willing to avoid conflict with other traffic movements or pedestrians crossing at junctions. However, for RM systems, there are no such conflicting movements and therefore drivers on slip road sections may not stop during amber periods.

Real traffic data taken from RM section on the M56 J2, as discussed in section 4.9.2, suggested that most drivers continue their movements during the stopping amber periods. In the model, both compliance and non-compliance approaches for drivers during the amber periods are included. In the case of compliance, Equation 5-27 is applied to check whether a driver is able to stop before overshooting the stop line. In the case of non-compliance (which is the default), drivers are assumed to use the amber periods in a similar way to the way that they use green periods.

### **5.11. Model capabilities**

The model is designed in order to test the effect on travel time using certain traffic management controls such as speed limits, lane changing restrictions and RM. In addition, all related parameters by these controls and also the geometric layout of the section are easily changed in the input file in order to assess the effect of applying different values.

### **5.12. Summary**

This chapter described the developed simulation model for merge sections. The car following, lane changing and merging rules were discussed in addition to a discussion of some of the RM algorithms that are integrated in the model. The rules used in the simulation model were based on real observations from UK motorway sites as well as based on some related previous studies. The next chapter will present the verification, calibration and validation processes of the model using real data taken from different motorway sites.

## CHAPTER SIX : MODEL VERIFICATION, CALIBRATION AND VALIDATION

### 6.1. Introduction

The reliability of any traffic simulation model depends on how well a model can represent real traffic data (Barceló and Casas, 2002). In fact, exact replication for traffic parameters cannot be achieved as it mainly depends on human behaviour that is subject to change because of many reasons. However, simulating errors should not exceed permitted limits.

In the previous chapter, the developed sub models (rules) for car following, lane changing and merging behaviour were explained. This chapter presents the verification, calibration and validation processes for these rules and also for the whole simulation model.

The verification process involves identifying any possible errors and checking the performance of the model (Olstam and Tapani, 2011) while the calibration process covers estimating the parameters for all the model parts (e.g. car following, lane changing and merging rules) by comparing the simulation results with real data (Barceló and Casas, 2002 and Chu *et al.*, 2003). The model validation involves testing the whole of the simulation model using different set(s) of data.

Olstam and Tapani (2011) showed the requirement for the structure of any simulation model as shown in Figure 6-1. The figure suggests that the verification, calibration and validation processes are repetitive since any discovered error may require adjusting the model's assumptions and/or its parameters.

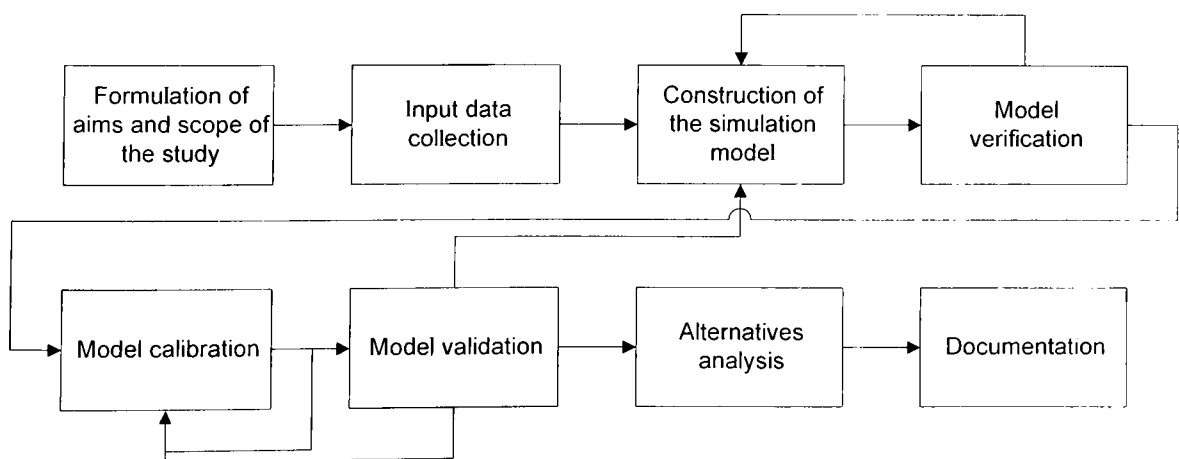

Figure 6-1 Simulation study workflow (Source: Olstam and Tapani, 2011)

## 6.2. Statistical tests

In addition to the graphical representation, quantitative comparison between the observed data and the simulation results should be applied using suitable statistical test(s). The selection of an appropriate statistical test depends on the sort of the data used. Wu *et al.* (2003) reported that using Kolmogorov-Smirnov and other similar non-parametric tests are not useful if the comparison involves time-series data such as the data obtained from traffic loop detectors. In such cases, other tests were suggested. The root mean square error (RMSE) and the root mean square error percentage (RMSEP) as shown in Equations 6-1 and 6-2 were widely applied to test the system error in traffic simulation models. In using these two tests, lower values suggest better representation for the real data. These two tests were adopted by many simulation studies (see for example, Barceló and Casas (2002), Toledo (2003), Wang (2006), Choudhury (2007) and Choudhury *et al.* (2009)).

$$\text{RMSE} = \sqrt{\frac{1}{n} \sum_{i=1}^n (x_i - y_i)^2} \quad \text{Equation 6-1}$$

$$\text{RMSEP} = \sqrt{\frac{1}{n} \sum_{i=1}^n \left(\frac{x_i - y_i}{x_i}\right)^2} \quad \text{Equation 6-2}$$

where,

$n$  is the number of time intervals,  
 $x_i$  is the actual data at time interval  $i$ , and  
 $y_i$  is the simulated results at time interval  $i$ .

Hourdakis *et al.* (2003) suggested that using the coefficient of correlation ( $r$ ) obtained from Equation 6-3 could measure the strength of the linear relationship between the actual and simulated samples.

$$r = \frac{1}{n-1} \sum_{i=1}^n \frac{(x_i - \bar{x})(y_i - \bar{y})}{\sigma_x \sigma_y} \quad \text{Equation 6-3}$$

where,

$\bar{x}$  and  $\sigma_x$  are the mean and the standard deviation for the actual data, and  
 $\bar{y}$  and  $\sigma_y$  are the mean and the standard deviation for the simulated results.  
 Recently, the Theil's inequality coefficient ( $U$ ) represented in Equation 6-4 was extensively used in validating traffic simulation models (see for example, Hourdakis *et al.* (2003), Brockfeld *et al.* (2005) and Wang (2006)). This test measures how well a time series of estimated values is close to a corresponding time series of

observed values. Barceló and Casas (2002) suggested that the inequality coefficient (U) is more efficient in comparing two time series than the RMSE or RMSEP.

$$U = \frac{\sqrt{\frac{1}{n} \sum_{i=1}^n (x_i - y_i)^2}}{\sqrt{\frac{1}{n} \sum_{i=1}^n x_i^2 + \frac{1}{n} \sum_{i=1}^n y_i^2}} \quad \text{Equation 6-4}$$

The U values lay between 0 and 1 with a value of 0 representing a perfect fitting. The U comes with three related measurements according to the following equation:

$$U_m + U_s + U_c = 1 \quad \text{Equation 6-5}$$

Here  $U_m$  measures the difference between the mean values while  $U_s$  measures the difference between the standard deviations. Again lower values for the  $U_m$  and  $U_s$  give better fitting to the data. The  $U_c$  is a measure for the unsystematic error which should be near to the value of 1. These latter three measurements can be obtained using the following equations:

$$U_m = \frac{n(\bar{x} - \bar{y})^2}{\sum_{i=1}^n (x_i - y_i)^2} \quad \text{Equation 6-6}$$

$$U_s = \frac{n(\sigma_x - \sigma_y)^2}{\sum_{i=1}^n (x_i - y_i)^2} \quad \text{Equation 6-7}$$

$$U_c = \frac{2n(1-r)\sigma_x\sigma_y}{\sum_{i=1}^n (x_i - y_i)^2} \quad \text{Equation 6-8}$$

However, Leuthold (1975) suggested that applying Equation 6-4 leads to improper use for the U and suggested that Equation 6-9 is more appropriate (i.e. by removing the simulation part from the denominator).

$$U^* = \frac{\sqrt{\frac{1}{n} \sum_{i=1}^n (x_i - y_i)^2}}{\sqrt{\frac{1}{n} \sum_{i=1}^n x_i^2}} \quad \text{Equation 6-9}$$

It should be noted here that the units of the results obtained from using the RMSE test follow the units of the parameters which were used in the test. For example, when testing the actual and simulated speeds, the units of the RMSE will be in km/hr. The units for RMSEP test are in percentage, while all other tests (i.e. r and U test) are scalar quantities.

In this research and in order to satisfy that the model could reasonably replicate real data, all the above measurements have been used. In addition, the model behaviour is compared with the well-known S-Paramics simulation model using the same data.

### 6.3. Model verification

The model verification process represents reviewing the rules applied in the model to ensure that these rules are working as desired (Olstam and Tapani, 2011). Dowling *et al.* (2004) suggested that the verification tasks include software error checking (i.e. coding errors), input coding error checking and animation review.

The main rules and assumptions used for car following, lane changing and merging are as described in sections 5.8 and 5.9. This section describes the verification process undertaken for these rules.

The verification tasks were considered during the model development by using output text files for the simulation results and also the animation environment of the model. Figure 6-2 shows a typical screenshot from the model run. This could shown throughout the simulation run and could be stopped at any time during the run to check, for example, position of vehicles, lane changing, relative speeds between lanes and within lanes, ...etc. In addition, warning messages were used in the code, during the model development process, to abort running the simulation model in the case of receiving any error (e.g. where two vehicles might conflict in the system). Once the detected errors were removed, the car following, lane changing and merging rules and also the whole simulation model were examined against the logical behaviour.

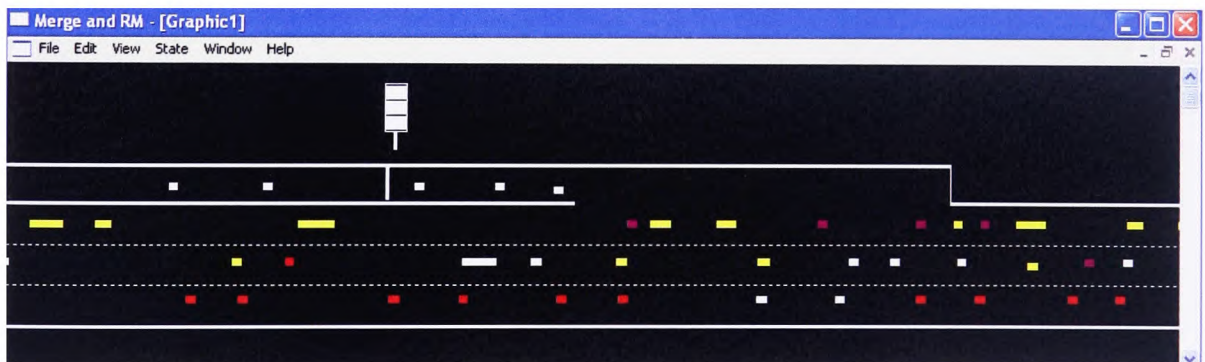

Figure 6-2 Typical screen from the model

#### 6.3.1. Car following rules (CFR)

The visual angle CFR were used in the early stages of this research since the model uniquely included the width of vehicles into consideration when determining the safe following distance between successive vehicles. It is also suggested that the visual angle CFR could reasonably include the effect of traffic conditions on drivers' reaction time (see Al-Obaedi and Yousif, 2009). However, the visual angle CFR assumption of leaving a

larger following distance if the leader is a HGV rather than a small car was found not to be the case for the majority of UK drivers (see Yousif and Al-Obaedi, 2011). Therefore the rules of car following have been completely changed by applying different CFR (i.e. CARSIM as discussed in section 5.8).

However, further testing for CARSIM detected some limitations as discussed in section 5.8 and therefore the rules have been modified accordingly. The behaviour of the modified CFR and CARSIM was compared in section 5.8. In addition, and as shown in Appendix E, the CFR have been tested based on local stability and on its ability to react to the following distance as suggested by Wu *et al.* (2003).

### 6.3.2. Lane changing rules

The verification process of the lane changing rules has been conducted by checking the following:

- Eliminating the cases of “zigzag” lane changes.
- For discretionary lane changing, lane changing to the right lanes should enhance the condition of the lane changer. Also, lane changing to the left lanes should not result in reducing the lane changer’s speed.
- The frequency of lane changes should have a similar pattern to that observed on sites (see section 4.7.1).
- The lane changing process should not involve having conflicts with other vehicles (i.e. safe maneuvering).

### 6.3.3. Merging rules

Many of the cases that were required to be adjusted were found during the building of the merging rules (i.e. mandatory lane changing). These included:

- Cases where the lag vehicle (J2) (see Figure 6-3) shifts to other lanes on the right in order to help/avoid the merger vehicle (C). The initial model’s assumptions calculated the lag gap based on J2 until it completely shifts to the right lane. Real observation from the M60 J10 showed that vehicle C, in such cases, will directly accept the lag gap once J2 starts its manoeuvring to the right. Therefore, the model has been adjusted to include such cases taking the effect of the lag vehicle J3 (as shown in Figure 6-3) into the calculations of the lag gap required. If the new lag gap with respect to J3 is accepted and the lead gap is accepted, vehicle C will start its merging process.



- In cases where vehicle J2 undertook a cooperative behaviour (i.e. decelerating) the vehicle C will not accept the lag gap until it becomes higher than the minimum required lag gap. In reality, the process of merging starts once the merger C receives such cooperative behaviour (e.g. by flashing overhead lights). Therefore the minimum lag gap was reduced in such situations by lowering the “ $\alpha$ ” parameter used in Equation 5-22 to a value of 0.2. The use of lower values for lag gaps required in cooperative cases is consistent with the findings by Choudhury (2007).
- In the cases where the lag gap is accepted while the lead gap is rejected, the model assumptions described in the section 5.9.2 enable vehicle C to decelerate in order to create a larger lead gap. In some situations, where the speed of J1 is already higher than that of C, it seems that there is no need for such deceleration (especially if vehicle C has a sufficient distance before reaching the end of the auxiliary lane EOAL). Such behaviour is seen from various merge sections filmed on videos. Therefore, the assumptions been modified to estimate the time required to merge without slowing down. If this time was lower than the time required to reach the EOAL, no deceleration rate will be applied by vehicle C.
- It is assumed that drivers on a slip road will accelerate/decelerate in order to match the local speeds of the nearest lane of the motorway once they approach the merge section (by changing their instant desired speed). However, in the case where the speed of the traffic in the inside lane of the motorway section was very low (e.g. 30 km/hr), this assumption leads sometimes to creating bottlenecks on the ramp section just at the start of the auxiliary lane. Such bottlenecks do not occur in real life based on observations from a variety of sites. Therefore, this assumption has been ignored in such cases.

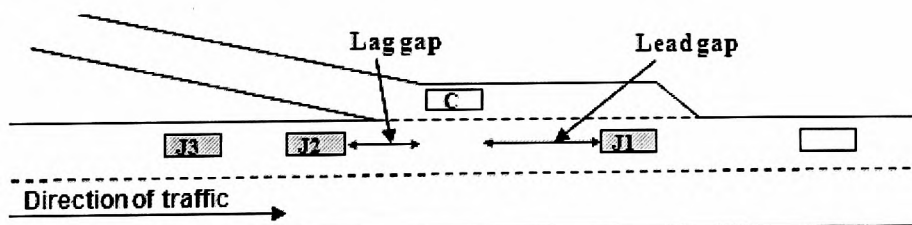

Figure 6-3 Merger vehicle with respect to motorway traffic

## 6.4. Model calibration

This section describes the calibration process for car following, lane changing and merging rules. It should be noted here that the results presented in this section have been achieved after repetitive iterations for the model's verification, calibration and validation, as discussed in section 6.1 (see Figure 6-1). During such repetitive processes, the rules were modified (to be as described in section 5.8 for the car following rules and as described in section 5.9 for the lane changing and merging rules) in order to get as good replication as possible with real data and observations.

### 6.4.1. Car following rules (CFR)

Finding suitable data for testing CFR is difficult to achieve as it requires trajectory data for speeds and positions of vehicles for a considerable period and for different traffic conditions. This cannot be obtained without expending extensive resources. However, an extensive research has been conducted to search for such data from the UK. Unfortunately, this proved to be either limited or not available in a format that could be used here to calibrate the model. Therefore, published real traffic data from instrumented vehicles from Germany and USA as well as other resources from the USA have been used.

#### *a. Trajectory data from Germany (Data Set 1)*

The data is taken from Panwai and Dia (2005) and is based on two vehicles' trajectories when these vehicles are travelling at stop-and-go conditions for a distance of 2.5 km and for a period of 300 seconds. The speed range is between 0 and 60 km/hr. The details for this set of data are shown in Figure 6-4. The figure shows the speed profile for the leading vehicle as well as the clear spacing between the two vehicles. The figure shows that both vehicles came to a full stop several times during the whole period of 300 seconds. The relative speed between the leading and the following vehicles is presented in Figure 6-5. For the purpose of this research, numerical values for the leading speed and the clear spacing are extracted for each 0.5 second interval.

It is worth mentioning that this set of data has been used extensively in evaluating many of the well-known microscopic simulation models such as PARAMICS (Duncan, 1995), VISSIM (Wiedemann, 1974) and AIMSUN models (Barceló *et al.*, 1996). The RMSE varied between 5 and 10m with the best results obtained by using the AIMSUN model.

In testing the CFR (see section 5.8) using this set of data, values of -3.6 and -4.9 m/sec<sup>2</sup> were respectively used for the alerted and non-alerted maximum deceleration rates. The

alerted situation is identified when the spacing (front to front) between the two vehicles is less than 27m (equivalent to a traffic density of 37 veh/km).

The values of the RMSE obtained from comparing the actual and the simulated clear spacing was found to vary from 4.78 to 7.8m based on the value selected for the reaction time of the follower. These values are in good agreement with the data and suggested the validity of the CFR used even with variable drivers' reaction time. Figure 6-6 shows the best results when comparing the actual and simulated clear spacing. The observed and simulated speeds were also compared (see Figure 6-7) and the RMSE value was found to be only 2.8 km/hr.

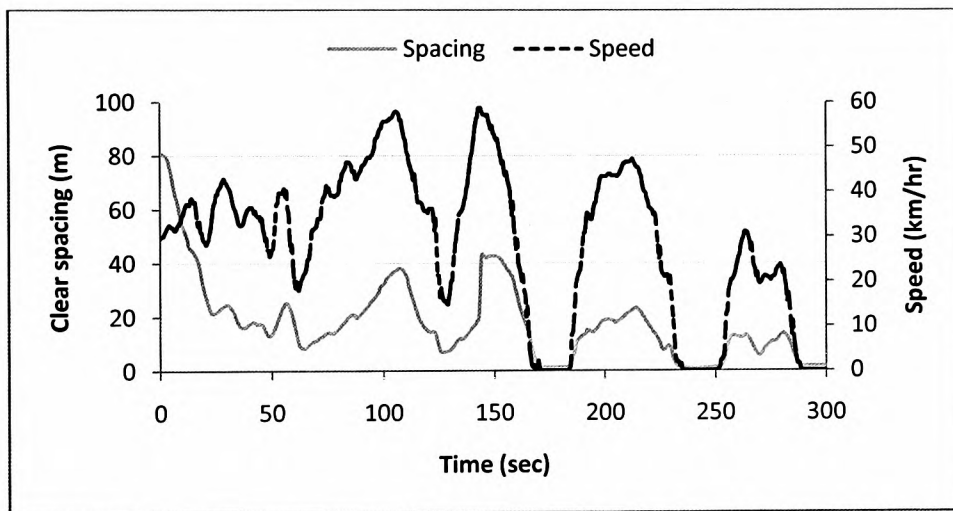

Figure 6-4 Instrumented data Set 1 (from Germany) showing clear spacing and leading vehicle speed profiles based on Panwai and Dia (2005)

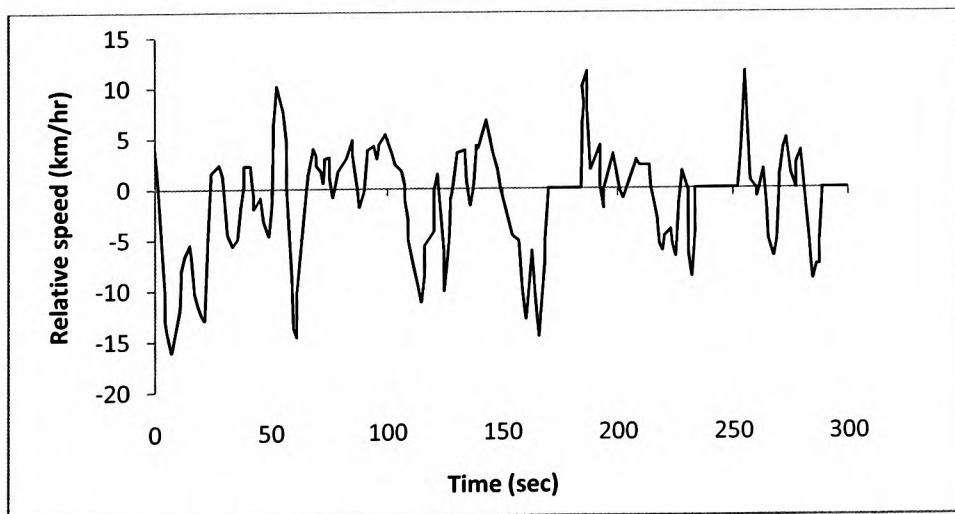

Figure 6-5 Instrumented data Set 1 (from Germany) showing relative speed between the leading and the following vehicles based on Panwai and Dia (2005)

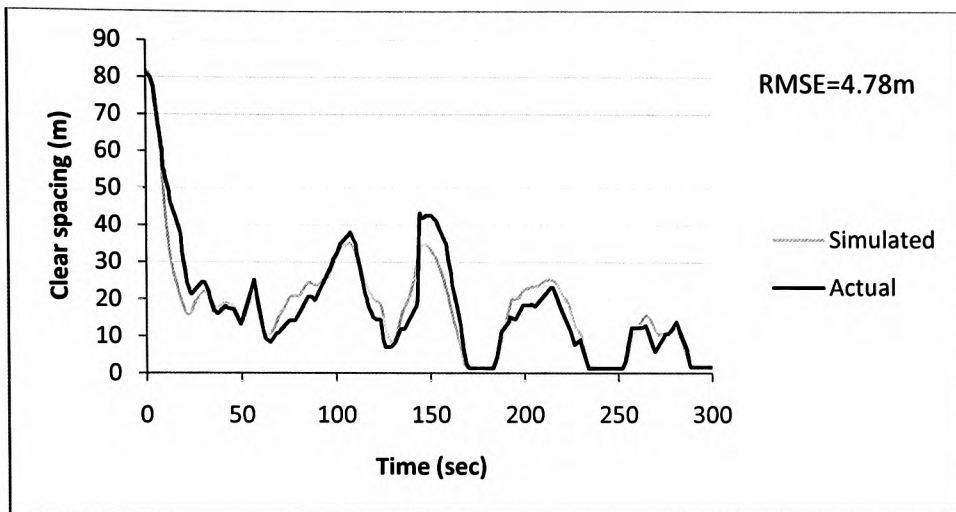

Figure 6-6 Actual and simulated clear spacing based on data Set 1

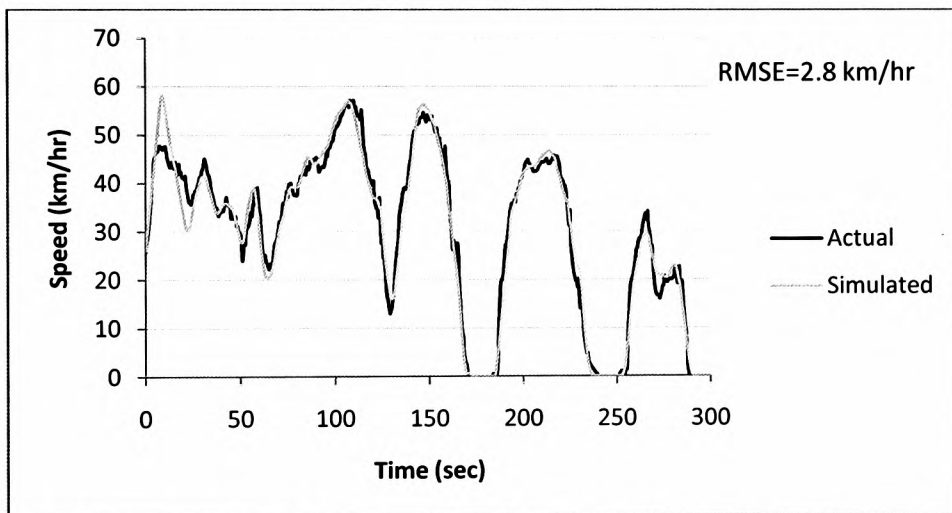

Figure 6-7 Actual and simulated clear speed based on data Set 1

*b. Trajectory data from the USA (Data Set 2)*

This set of data is taken from Sauer and Andersen (2004) from the USA. Here, the instrumented vehicle follows its leader with speeds between 95 and 120 km/hr for a period of 120 seconds. Both the speed of the instrumented vehicles and the clear spacing between the two vehicles are presented in Figure 6-8. As in data Set 1, numerical values for the leading speed and the clear spacing are extracted for each 0.5 second interval. Figure 6-9 suggests that the model could reasonably simulate real data when the RMSE between the simulated results and the actual data is 4.66m.

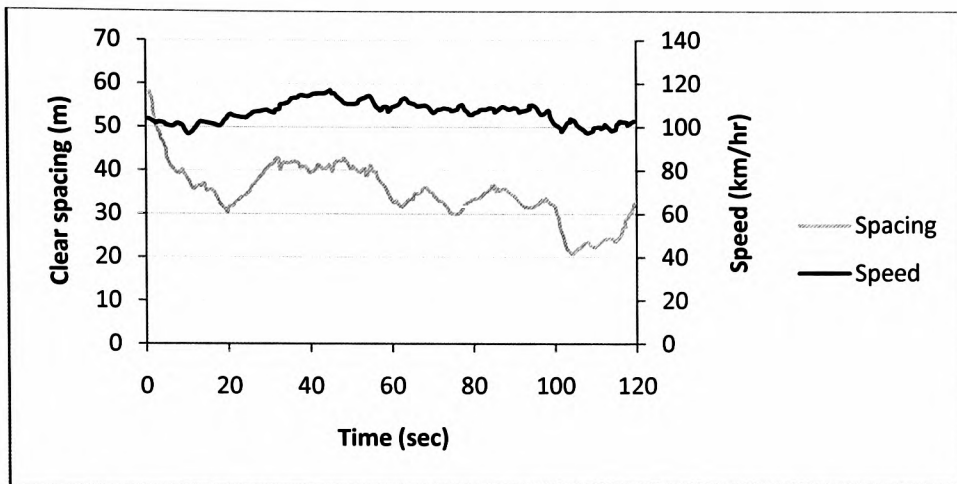

Figure 6-8 Instrumented data Set 2 (from USA) showing clear spacing and leading vehicle speed profiles based on Sauer and Andersen (2004)

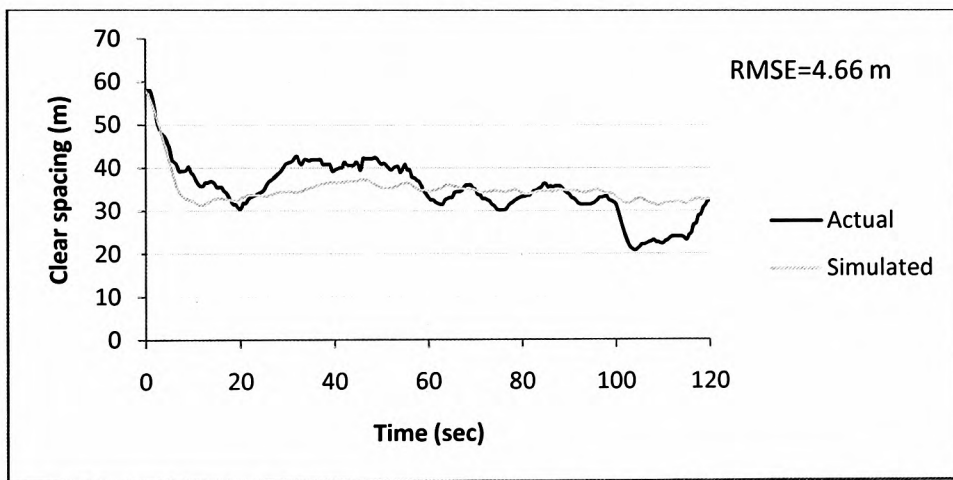

Figure 6-9 Actual and simulated clear spacing based on data Set 2

c. *Platoon of vehicles (Data Set 3)*

This is based on trajectory data for a platoon of vehicles abstracted from a series of cameras installed on top of a high building consisting of 30 stories in the USA (Federal Highway Administration, <http://ops.fhwa.dot.gov/trafficanalysisistools/ngsim.htm>) as shown in Figure 6-10.

For the purpose of testing, a platoon of 7 vehicles is selected from the data. Speeds and positions of the first vehicle are entered into the model while the positions for the other six vehicles are obtained from simulation and compared with the actual data. Figure 6-11 and Figure 6-12 are respectively showing the time-space diagrams for the actual and simulated data and suggest similar behaviour. The average root mean square error (RMSE) for the following 6 vehicles was 4.83m. The RMSE of individual vehicles' are shown in Table 6-1. The results suggested that the validity of the car following rules used in this study.



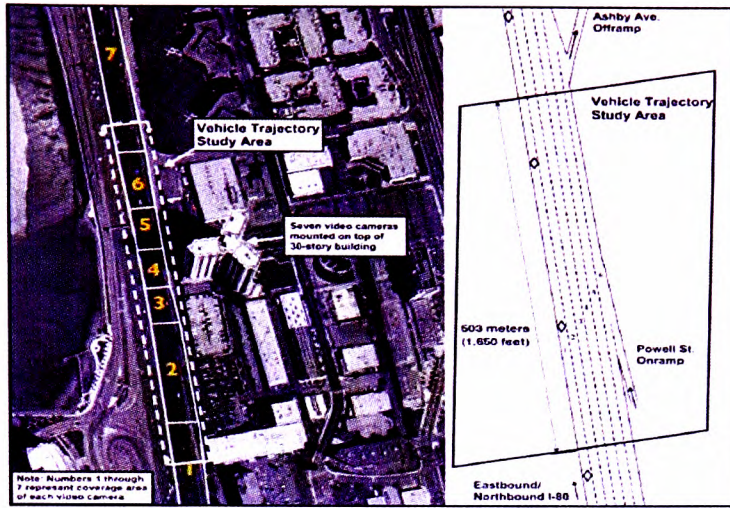

Figure 6-10 Sections covered by video cameras, (Source: <http://ops.fhwa.dot.gov/trafficanalysisistools/ngsim.htm>)

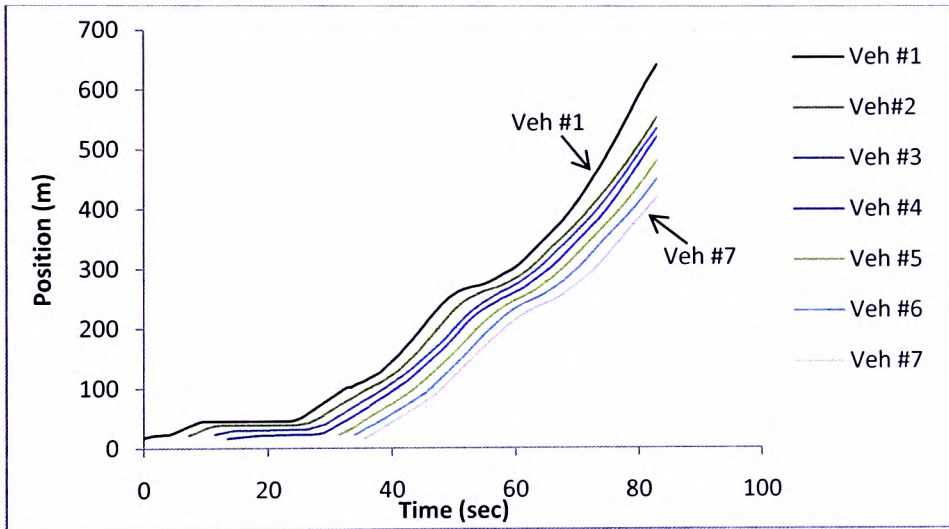

Figure 6-11 Actual time-space diagram for the platoon of vehicles

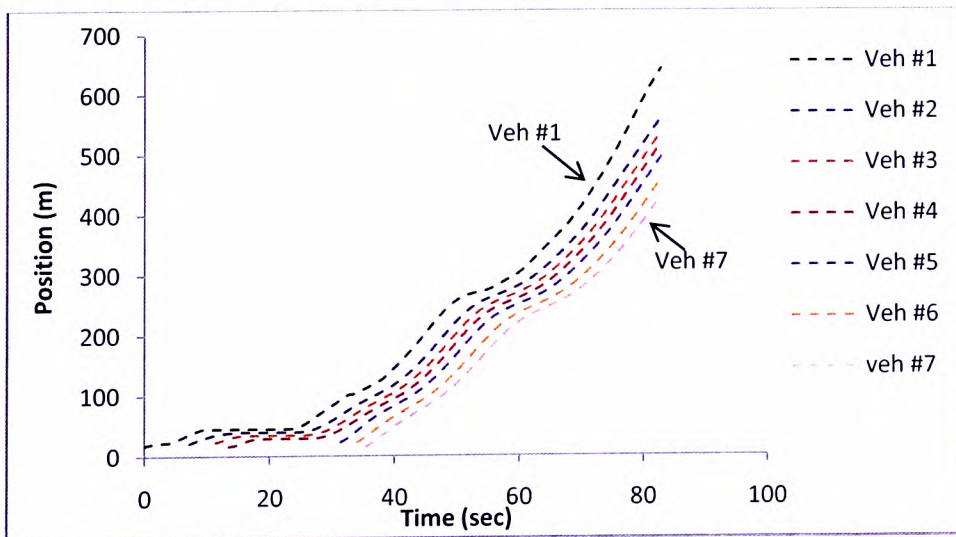

Figure 6-12 Simulated time-space diagram for the platoon of vehicles

Table 6-1 Summary for the RMSE values obtained from the simulation

Veh. No.	2	3	4	5	6	7	Average
RMSE	4.86	4.81	5.01	4.04	5.23	4.44	4.83

### 6.4.2. Lane changing rules

McDonald *et al.* (1994) suggested using lane utilisation and frequency of lane changes (FLC) data in calibrating simulation models. However, the same study discussed the difficulties associated with the calibration process and suggested that it is “impossible” to get exact replication for such real data especially at a moderated flow rate of 3500-4500 veh/hr for motorway sections with 3 lanes.

In this study, lane utilisation has been given a priority in assessing the results obtained. The FLC is also considered to check how the model could replicate the pattern of FLC with flow rates (as discussed in section 4.7). The reason for focusing on lane utilisation coefficients is because real data (e.g. Figure 6-13 based on data from the M62 with 3 lanes) suggested a strong correlation with the whole range of flow rates. In addition, the accuracy of estimating the flow distribution (as taken from loop detectors) could not be affected by human errors and the data collection methodology as in the case of estimating the FLC.

The data in Figure 6-13 suggest that the lane utilisation coefficients become equal when the total flow rate is about 4200 veh/hr (see the solid line in the figure). For a flow rate of about 6000 veh/hr, the coefficients are 0.22, 0.35 and 0.43 for lanes 1, 2 and 3 respectively.

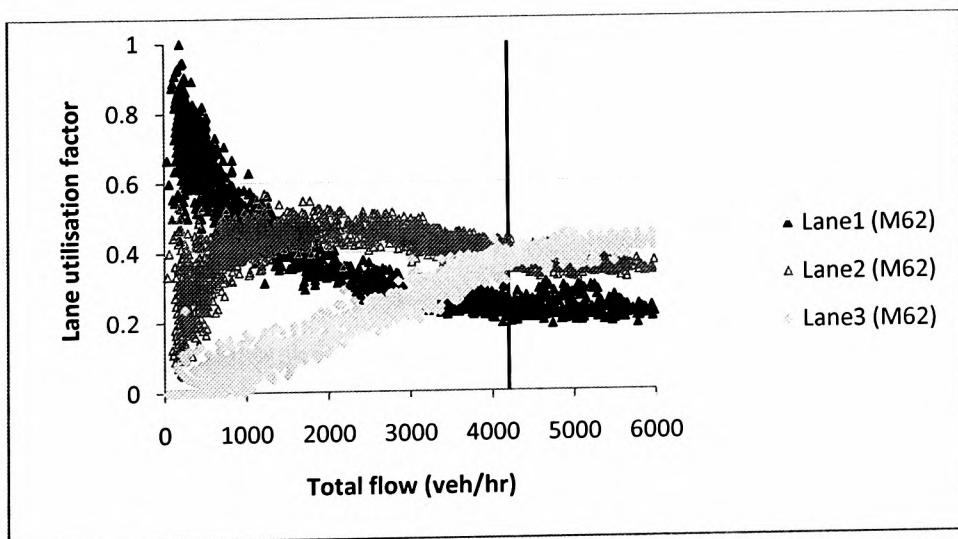

Figure 6-13 Lane utilisation coefficients for the M62 (3-lane section)

The calibration process has been carried out by conducting a sensitivity analysis for certain parameters given in Table 6-2 to test their effect on lane utilisation and FLC (see

section 5.9 for the definitions of these parameters). The other parameters of the lane changing rules are fixed (as explained in section 5.9). The underline values in the table represent the selected ones based on the sensitivity analysis. The simulation results were gathered at each 5 minutes interval from a section far away (2.5 km) from the start of the section in order to ensure that the results were not affected by the input lane utilisation coefficients. Flow rates up to 4000 and 6000 veh/hr were used in testing the simulation model for motorways with 2 and 3 lanes, respectively.

Table 6-2 The selected parameters for calibration of lane changing rules

Parameter	Value
D (m)	75, <u>100</u> , 125, 150
PD (%)	60, <u>80</u> , 100

For a motorway section with 3 lanes, Figure 6-14 shows the effect of the “D” parameter on the lane utilisation coefficients. The figure suggests that the 100m value provided a good representation for the data for all the ranges of flow rates. For example, compare the simulated and actual lane utilisation coefficients for flow rates of 4000 to 6000 veh/hr. In addition, the intersection of the simulated coefficients for lanes 2 and 3 (see the dashed line in Figure 6-14) was close to the intersection point obtained from the actual data (see the solid line in Figure 6-14). The use of 75m for the “D” parameter produced good representation for the data but only for flow rates less than 4500 veh/hr. For higher flow rates, the use of the 75m value caused a reduction in the lane utilisation coefficients for lane 3. Applying 125m for the “D” parameter resulted in increasing the lane utilisation coefficients for lane 3 for all the given flow rates.

The effect of the “D” parameter on FLC is shown in Figure 6-15 and shows that FLC increases with the decreasing of the “D” value. The pattern of the simulation results seems similar to that found by Yousif(1993) where the maximum FLC occurred at flow rate about 3000 veh/hr and started decreasing after that flow (see section 4.7.1). However, the use of 75m value provides higher FLC than those in real data given in section 4.7.1.

Based on the above, a fixed value of 100m was selected for the purpose of this study without considering that this parameter might be different from one driver to another (i.e. D has a distribution with minimum and maximum values). The reason for this is due to the difficulties associated with obtaining data for this parameter and to the fact that the results for D=100m gave reasonable results. The variability among drivers has already been



considered in the lane changing process through other parameters such as the magnitude (“R”) and the size of the accepted gaps as described in section 5.9.

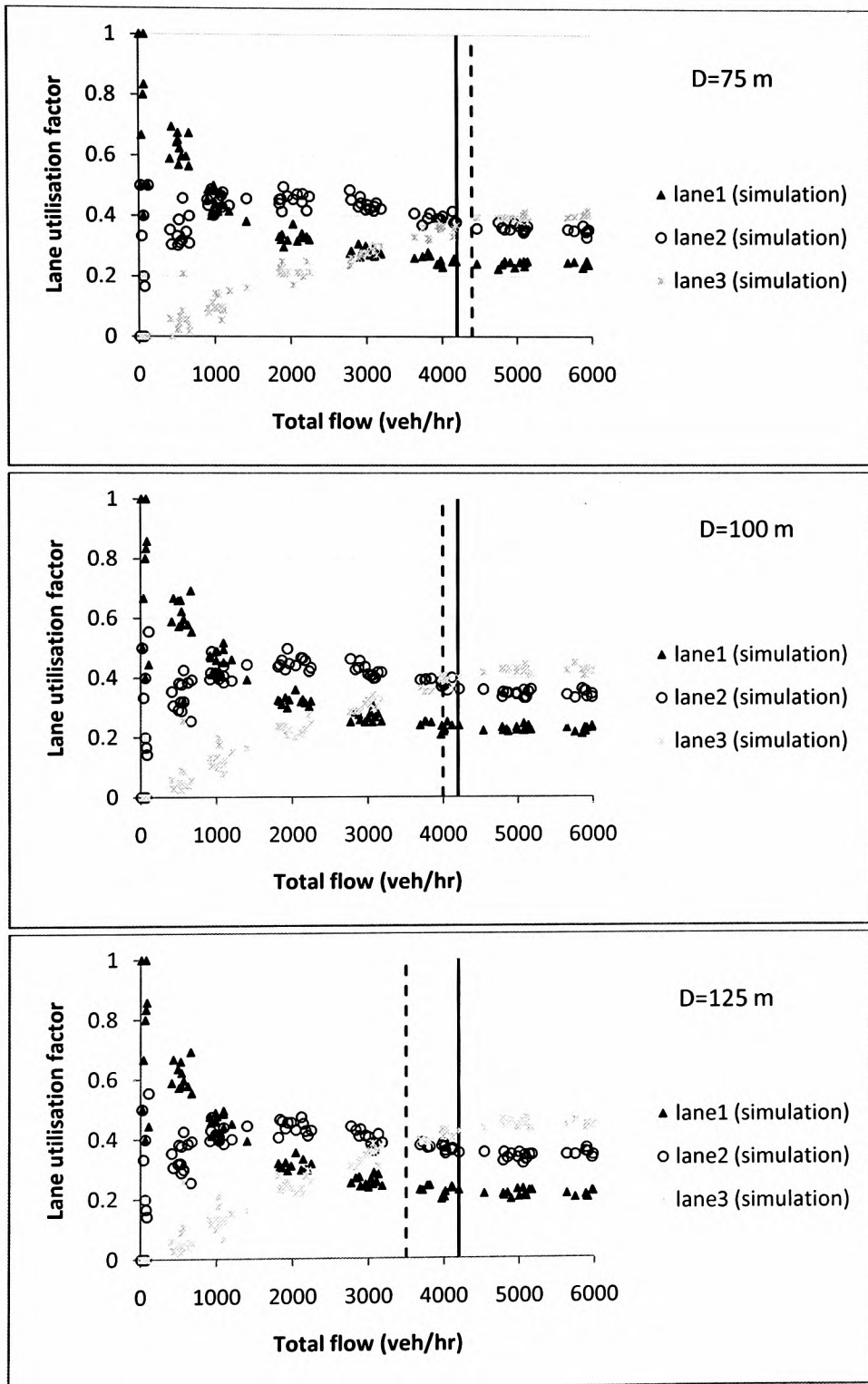

Figure 6-14 Simulated lane utilisation coefficients for a 3-lane section with different values of the “D” parameter

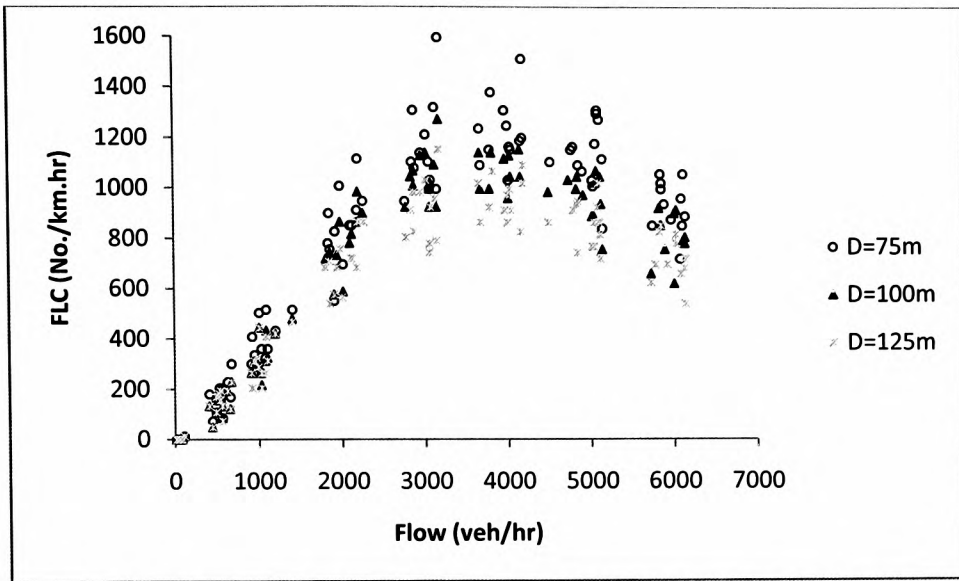

Figure 6-15 Simulated FLC for a 3-lane section with different values of the “D” parameter  
 The PD parameter (as described in section 5.9) is a percentage of slower drivers who are willing to return to their original lanes after overtaking slower traffic. This parameter slightly affected the results as shown in Figure 6-16 which shows the effect on FLC and Figure 6-17 which shows the effect on the lane utilisation coefficients. For the purpose of this study, a value of 80% is selected.

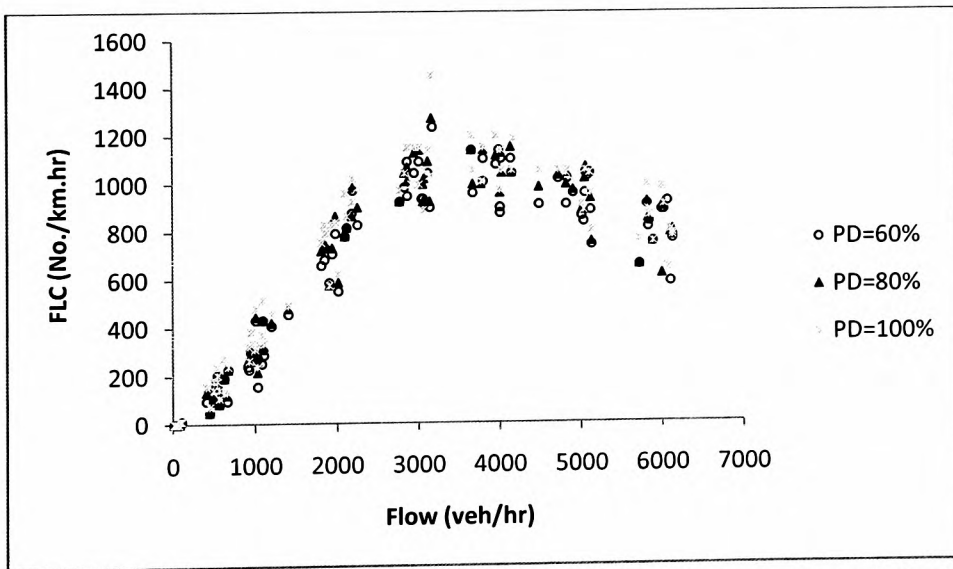

Figure 6-16 Simulated FLC for a 3-lane section with different values of the “PD” parameter

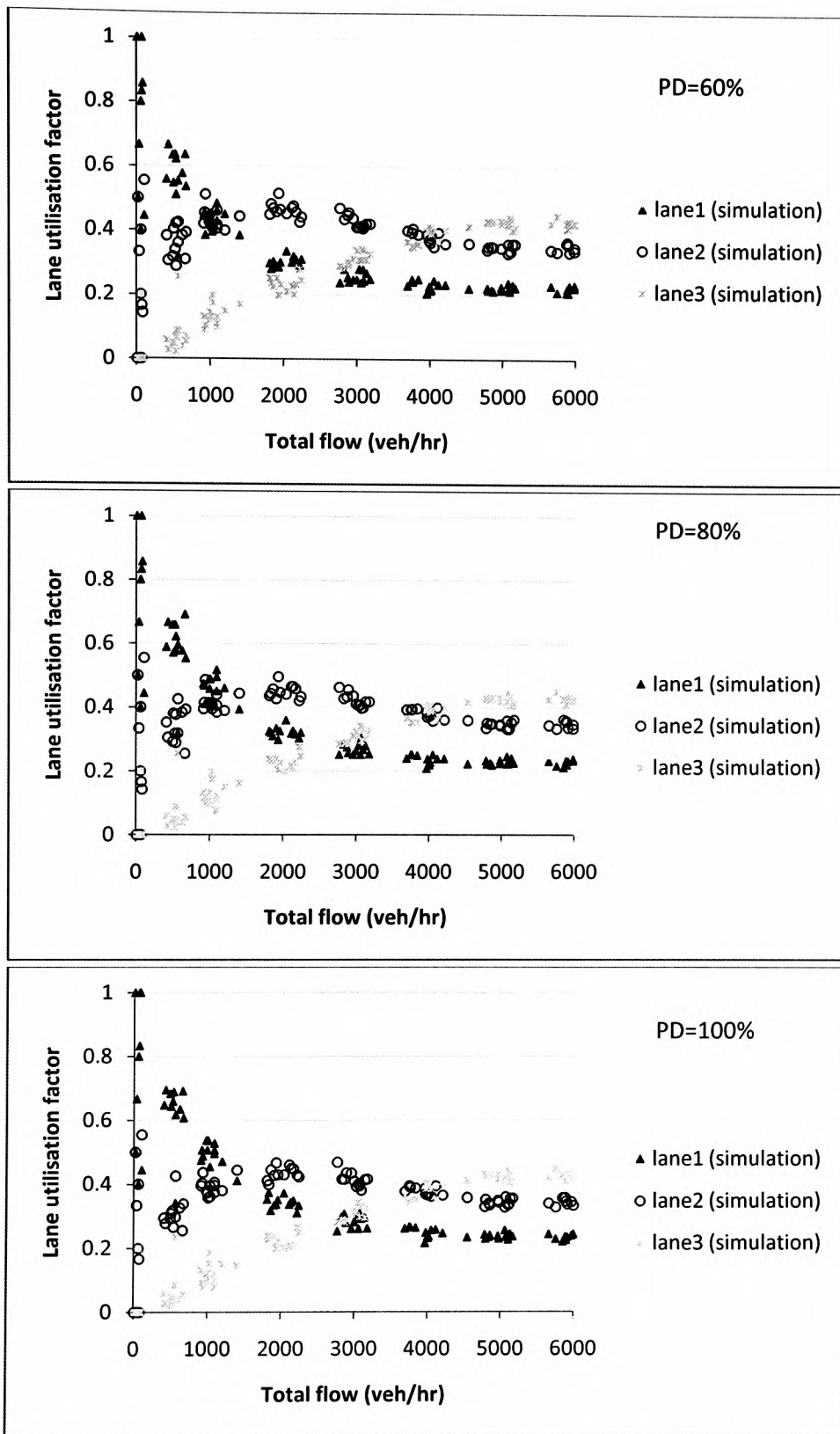

Figure 6-17 Simulated lane utilisation coefficients for a 3-lane section with different values of the “PD” parameter

The obtained parameter values based on data from the section with 3 lanes have been used in testing the model for a section with 2 lanes. Figure 6-18 shows the actual and simulated

lane utilisation data and reveals similar pattern. Figure 6-19 shows the simulated FLC and suggests similar behaviour to the real data by Yousif (1993) as presented in section 4.7.1.

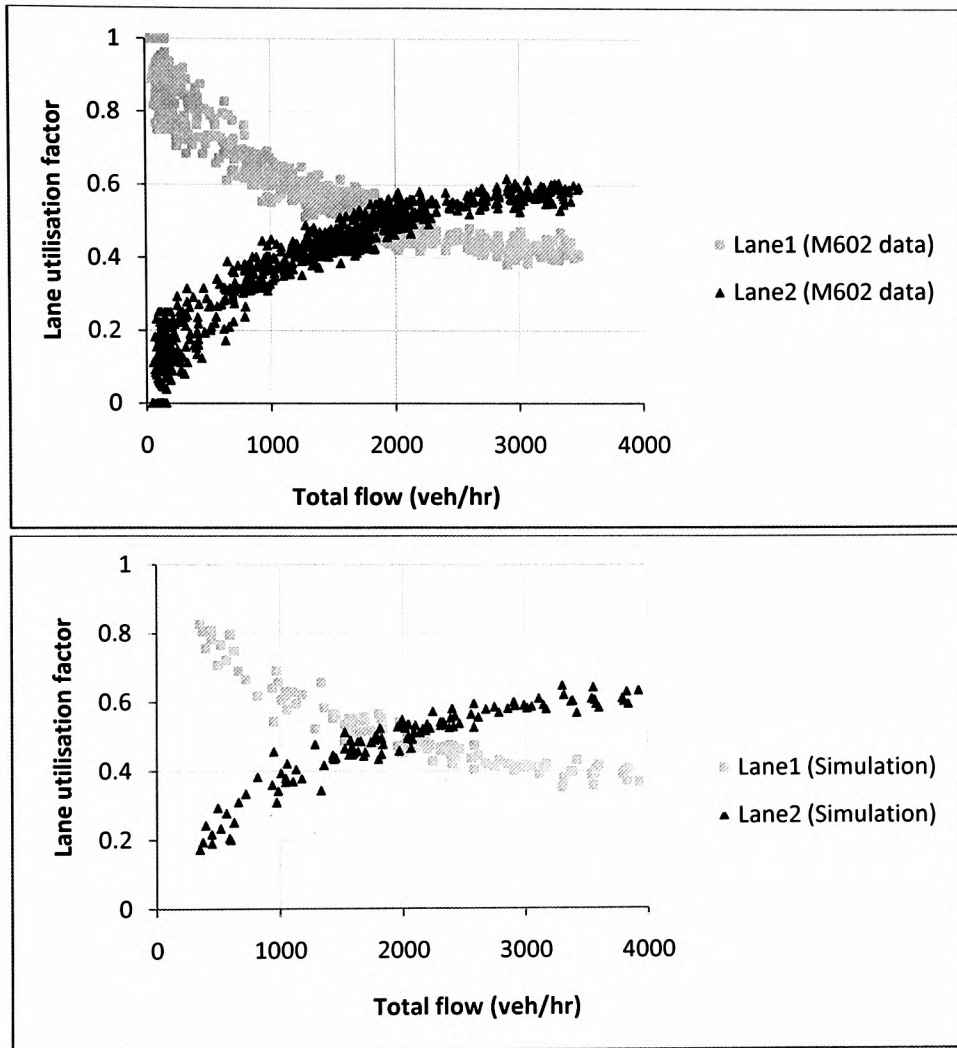

Figure 6-18 Actual and simulated lane utilisation factors for a 2-lane motorway

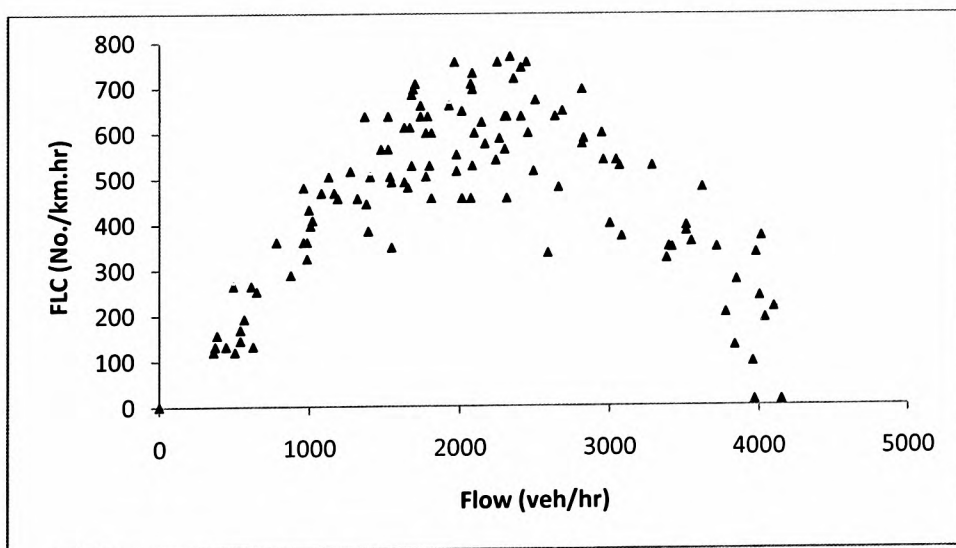

Figure 6-19 Simulated FLC for a 2-lane section

### 6.4.3. Merging rules

The merging rules have been calibrated in order to satisfy the following:

- Minimising the number of stopped vehicles at the end of the auxiliary lane (EOAL) as the real data has suggested. This is controlled by adjusting the ( $\alpha$ ) parameter used in estimating the safe lead and lag gaps.
- The acceleration/deceleration behaviour of traffic in the nearside lane is adjusted within the merge section by reducing the DRT during the relaxation period. This is applied using a reduction factor called DRTF.

*a. Using published data*

Real traffic data, as reported by Wang (2006) and originally taken from the work conducted by Zheng (2003), have been used here. This was used by comparing the distribution of the accepted lead and lag gaps for certain flow rates for ramp traffic and that of the nearest lane of the motorway from the M25 J11, as shown in Table 6-3. However, the data represents only 79 selected lead and lag gaps measured using a video recoding camera which ultimately provides some errors when used in estimating small gaps.

Table 6-3 Real traffic data from the M25 J11 (Source: Wang, 2006)

Parameter	Value
Length of acceleration lane (m)	182
Ramp traffic speed (km/hr) and flow (veh/hr), respectively	72, 932
Motorway traffic speed (km/hr) and flow (veh/hr), respectively	86, 1000
Yielding traffic (%)	6.63
HGVs (%)	5

The  $\alpha$  parameter is used in the calibration process. As described in section 5.9.1, a value of 1.0 is applied to  $\alpha$  in discretionary lane changing. This value is used for the “initial” test of the merging model and the results suggest a need to adjust this factor. Some trials have been conducted to fit the data and also to minimise the number of stopped vehicles at the EOAL. The results suggested  $\alpha$  of 0.3 and 0.5 for the lead and lag gaps, respectively. However, an  $\alpha$  value of 0.2 is used for both the lead and lag gaps in cooperative and forced merging situations (i.e. when a ramp vehicle failed to find enough gaps while approaching the EOAL). The DRTF of 0.2 and 0.5 were used during the relaxation process for sections before and after the EOAL, respectively. Figure 6-20 and Figure 6-21 show the cumulative distribution of the lead lag gaps obtained from the initial model (i.e. with  $\alpha=1$ ) and also from the calibrated model.

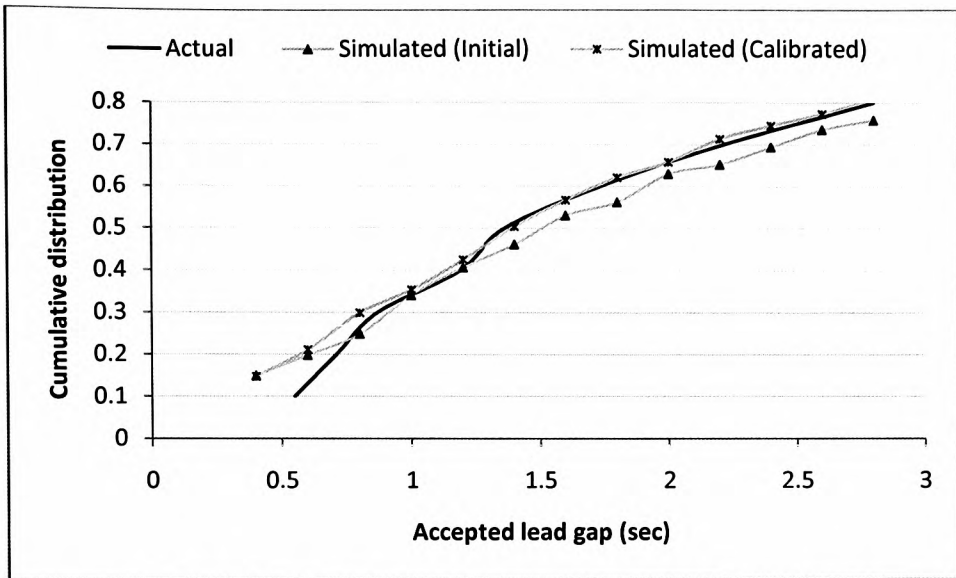

Figure 6-20 Actual and simulated distribution for merging lead gaps

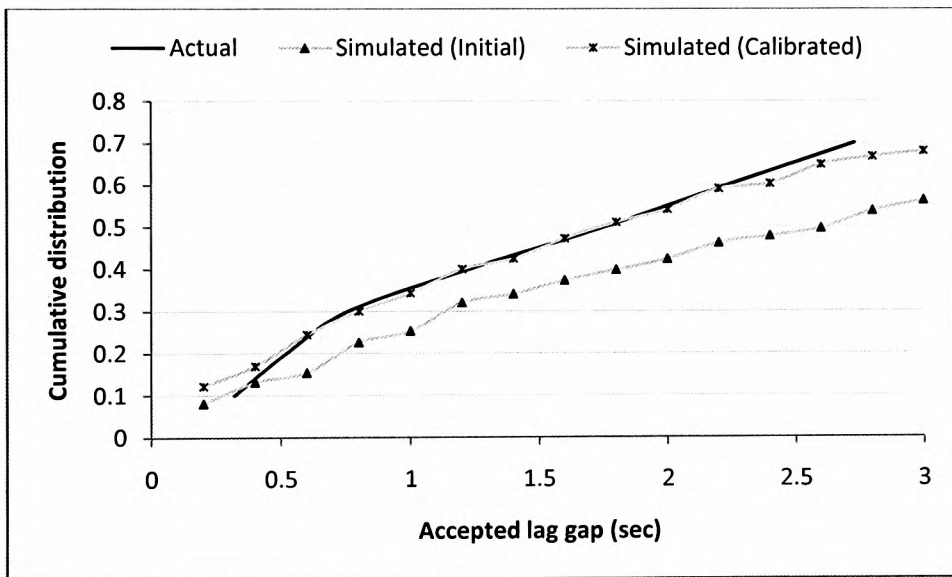

Figure 6-21 Actual and simulated distribution for merging lag gaps

The results from the calibrated model, as shown in these two figures, seem in good agreement with data. This is also obtained from a statistical test using the Kolmogorov-Smirnov non parametric test as shown in Table 6-4. The number of stopped vehicles at the EOAL was reduced from 34 vehicles (in the initial model) to zero (in the calibrated model).

Table 6-4 Kolmogorov-Smirnov test for the distribution of simulated lead and lag gaps

Lead gap (sec)	Lead gap		Lag gap (sec)	Lag gap	
	Cumulative distribution			Cumulative distribution	
	Actual	Simulated		Actual	Simulated
0.55	0.1	0.19	0.3	0.1	0.145
0.71	0.2	0.25	0.5	0.2	0.21
0.87	0.3	0.32	0.76	0.3	0.29
1.19	0.4	0.42	1.23	0.4	0.4
1.36	0.5	0.49	1.76	0.5	0.5
1.73	0.6	0.6	2.24	0.6	0.593
2.21	0.7	0.71	2.73	0.7	0.75
2.8	0.8	0.8			
Total sample	79	622	Total sample	79	622
$D_{\max}$	0.09		$D_{\max}$	0.05	
$D_{\text{cr}}$	0.16		$D_{\text{cr}}$	0.16	

b. *Using data from the M60 J10*

Data for the lead and lag gaps from the M60 J10, as reported in section 4.8.5, are used to compare the minimum observed lead and lag gaps with the simulated values. The flow rates and the percentage of HGVs that are used in the test are based on real observations as shown in Table 6-5. Figure 6-22 compares the simulated and minimum observed (the dashed line in the figure) lead gaps. Similarly, Figure 6-23 compares the simulated and minimum observed lag gaps. The results presented in these two figures suggest that the actual minimum lead and lag gaps could also replicate the simulated minimum lead and lag gaps.

Table 6-5 Flow inputs of the M60 J10

Parameter	Lane1	Lane2	Lane3	Ramp
Flow (veh/hr)	889.5	1378.5	1588.5	679.5
HGVs	20%	2%	0%	1%
Speed (km/hr)	90	110	118	72

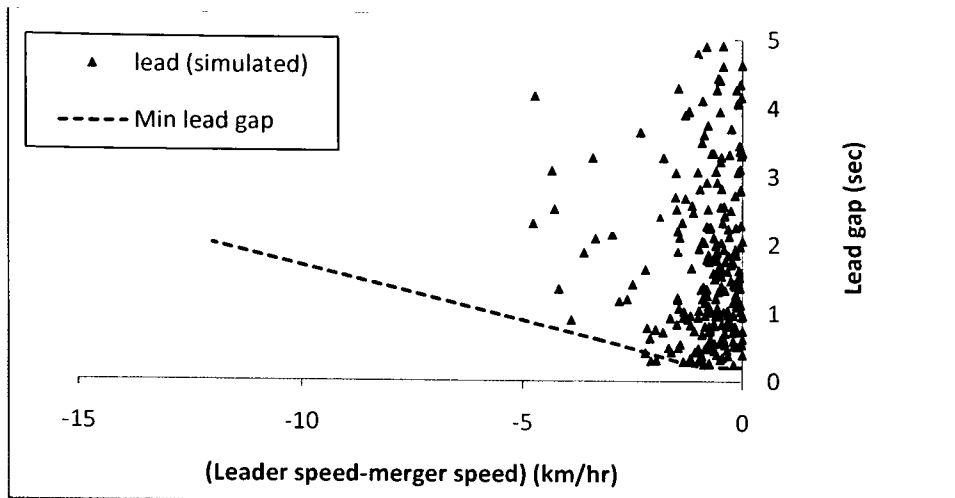

Figure 6-22 Simulated lead gaps and the minimum observed lead

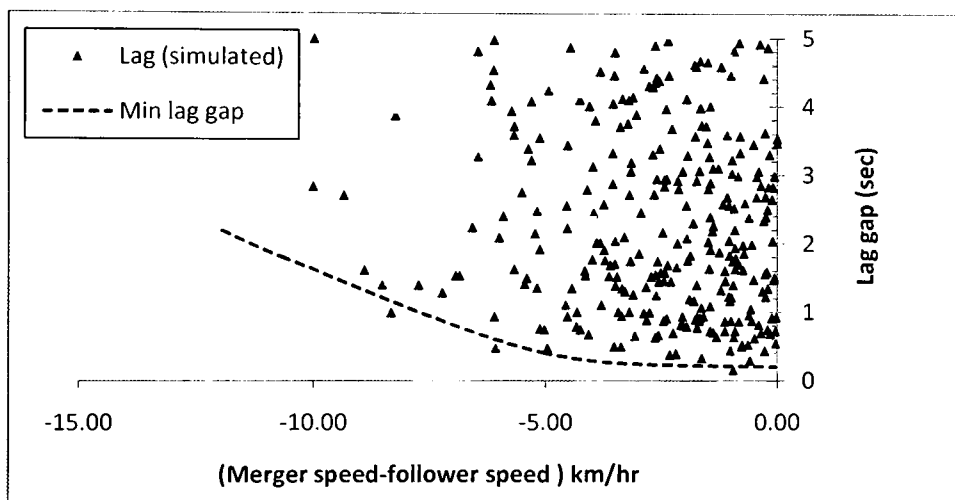

Figure 6-23 Simulated lag gaps and the minimum observed lag

## 6.5. Model validation

In the above section, the main parts of the developed micro-simulation model (i.e. car following, lane changing and merging rules) were calibrated and tested using various resources from real traffic data. However, there was still a need to check the performance of the whole model against real data before using the model in further applications.

Motorway Incident Detection and Automated Signalising (MIDAS) data for motorways with 2, 3 and 4 lanes have been used to validate the model at different levels of flows (i.e. from free flow to congested situations). The model has also been compared by S-Paramics' micro-simulation software using the given data. The comparison between simulated and real traffic data are mainly based on comparing the flow, speed and occupancy parameters for different locations based on the real position of the installed traffic loop detectors.



### 6.5.1. Comparison with M56 J2 data

This site consists of a 2-lane on-ramp merging with a 2-lane motorway section. It has many loop detectors' stations upstream and downstream from the merge section as shown in Figure 6-24. These loop detectors provide average data for each one minute time interval representing speed, flow, headway and occupancy. The junction is served by a RM device. However, the selected data for the test were for the cases where the RM was switched off since no data was obtained relating to the operation of the RM (such as the desired occupancy and the queues created on the ramp sections).

Two sets of data were used representing off-peak and peak periods. Flow rates taken from the upstream detectors' station (U2) as well as from the ramp detectors were used as inputs for the model. Data taken from other loop detectors' stations (i.e. U1, D1 and D2) were used for the purpose of comparison with the simulation results.

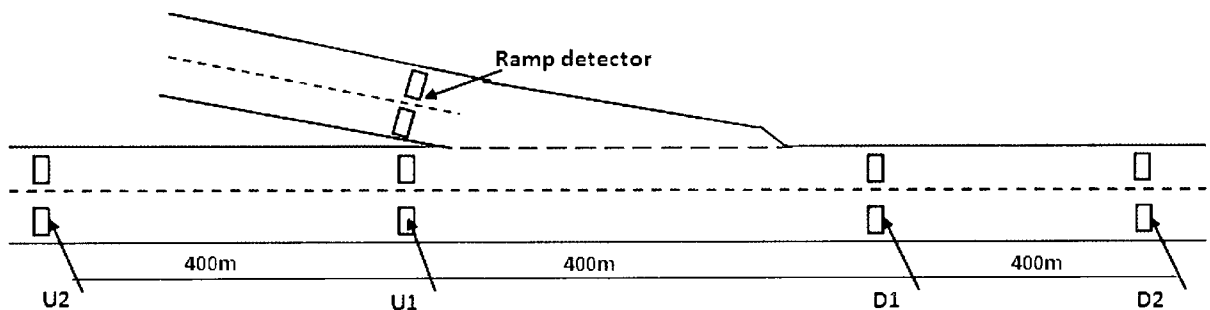

Figure 6-24 Locations of the loop detectors on the M56 J2

#### a. Comparison with the off-peak period

This data was taken from the loop detectors in the off-peak period from 11.00am to 1.00pm on 15/09/2009. The input data and the analyses were averaged for each 10 minutes' interval. Figure 6-25 shows the input flow data for the model for the motorway at detectors' station U2 and the ramp.

Figure 6-26 compares the simulated and actual data from the detectors' station D2. All the presented figures suggested good agreement of the simulation results with the real data for such traffic flow conditions.

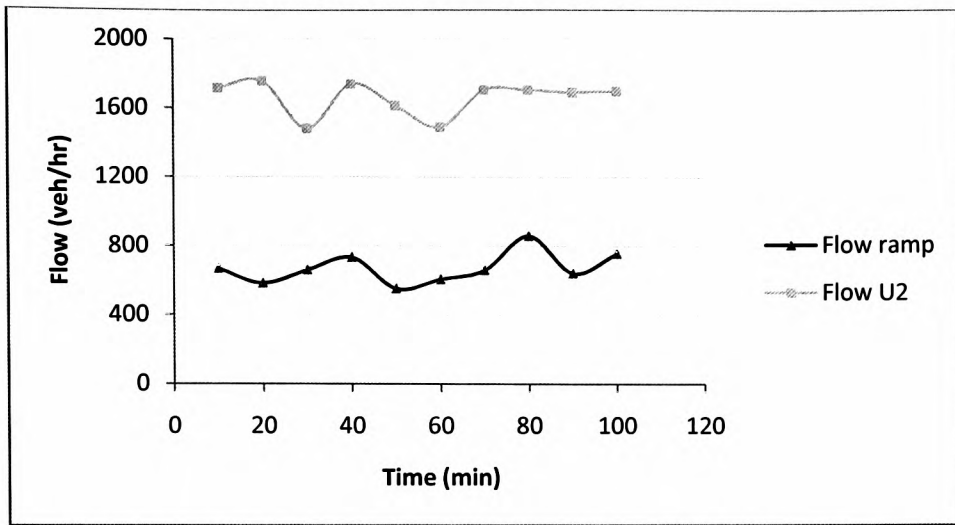

Figure 6-25 Actual input flow for the motorway and the ramp

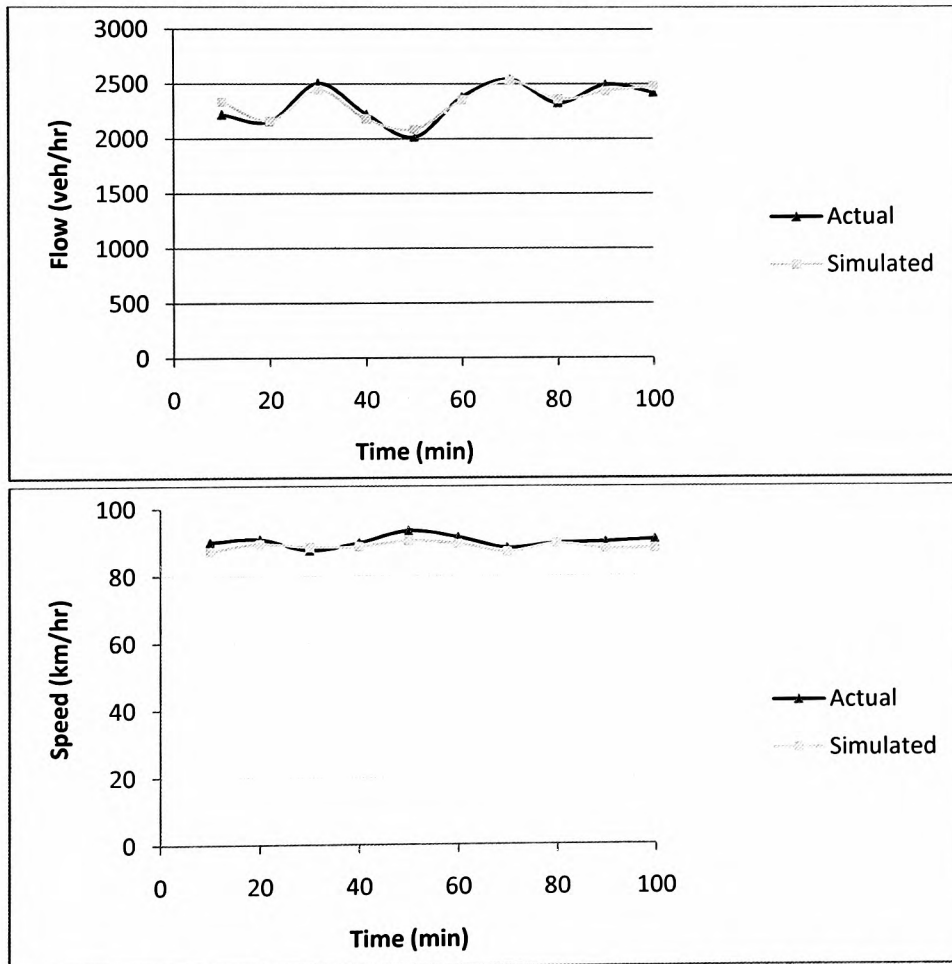

Figure 6-26 Actual and simulated flows and speeds at detectors' station D2

*b. Comparison with the peak period*

This data was taken from the loop detectors' stations (as shown in Figure 6-24) as well as recording data from video camera in the peak morning hours of 15/09/2009 for one hour

only. The ramp metering signal was operating in the last 10 minutes and therefore these latter 10 minutes were excluded. The input data for both motorway and ramp flow rates is presented in Figure 6-27. Graphical comparison between the actual data and the simulated results are presented in Figure 6-28 and Figure 6-29. Figure 6-28 shows the case for speed and flow parameters at detectors' station D1, while Figure 6-29 compares the simulated and actual flows by considering each lane separately. Both of the figures show that the model could reasonably represent real traffic at higher flows also.

The quantitative comparisons between the simulated and the actual data for all the detectors' stations (i.e. U1, D1 and D2) are presented in Table 6-6. This table shows that the results are within the acceptable limits based on studies by Toledo (2003), Brockfeld *et al.* (2005) and Wang (2006). The U (or U\*) value that measures the overall error is very small which indicates a good correlation based on the findings by Brockfeld *et al.* (2005). The root mean square error percentage (RMSEP) results suggest good agreements between the actual data and the simulated results.

Further verification has been conducted by comparing one minute of data of the speed-flow and flow-occupancy relationships as shown in Figure 6-30. Both these relationships show good agreements between the simulation and the actual data.

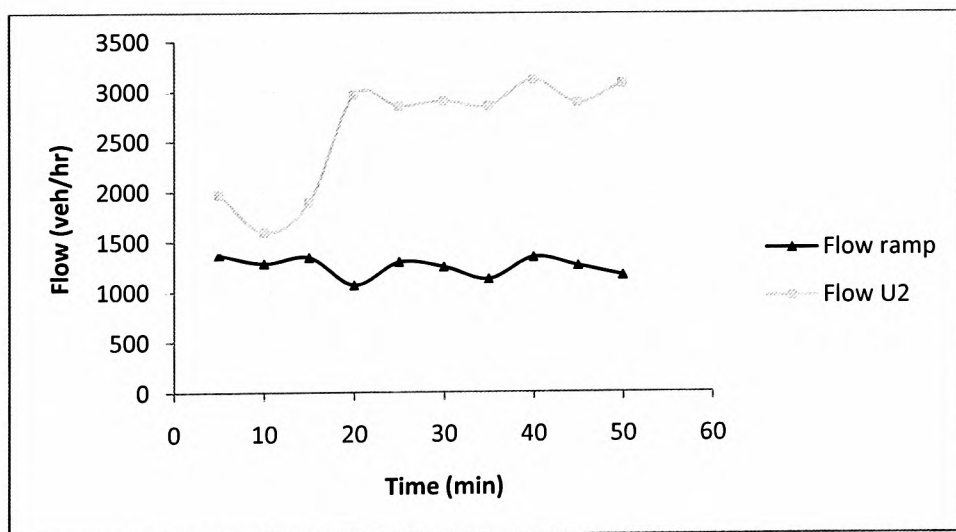

Figure 6-27 Actual input flow for the motorway and the ramp sections

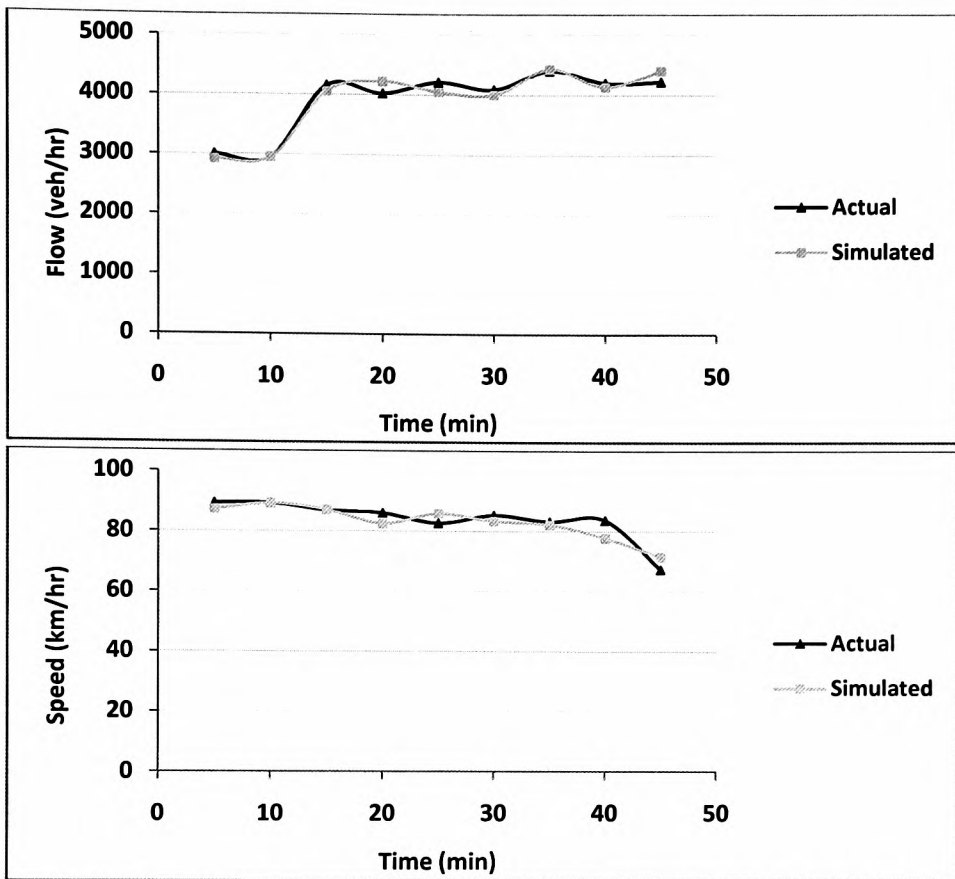

Figure 6-28 Actual and simulated flow and speed at detectors' station D1

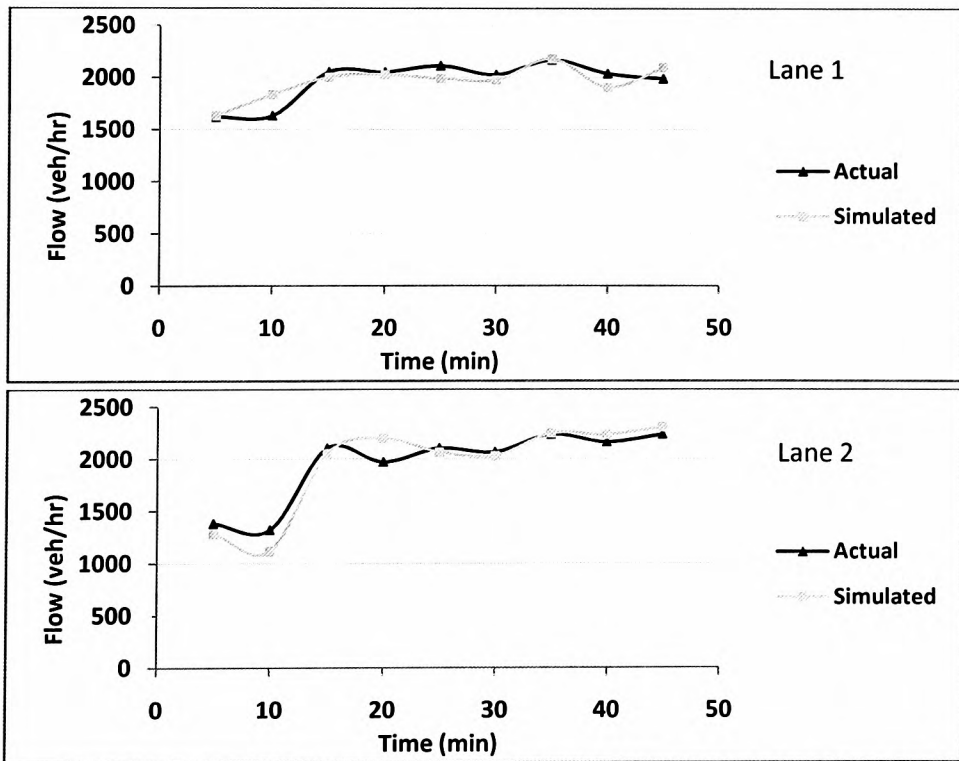

Figure 6-29 Actual and simulated flow in lanes 1 and 2 at detectors' station D1

Table 6-6 Statistical tests for the developed model based on data from the M56 J2

Detectors' station	Lane	RMSE	RMSEP (%)	r	Theil's inequality coefficient			
					U	U*	Um	Us
U1	Flow	53 (veh/hr)	2.0	0.996	0.01	0.019	0.051	0.21
	Speed	1.96 (km/hr)	2.3	0.771	0.01	0.021	0.002	0.002
D1	Flow	118 (veh/hr)	2.9	0.976	0.015	0.03	0.005	0.058
	Speed	3.0 (km/hr)	3.8	0.882	0.018	0.036	0.059	0.14
	Occupancy	1.32 (%)	7.0	0.882	0.038	0.076	0.04	0.2
D2	Flow	98 (veh/hr)	2.7	0.984	0.012	0.025	0.0	0.12
	Speed	2.1 (km/hr)	2.7	0.95	0.013	0.025	0.05	0.23
	Occupancy	0.69 (%)	5.1	0.95	0.02	0.042	0.29	0.01

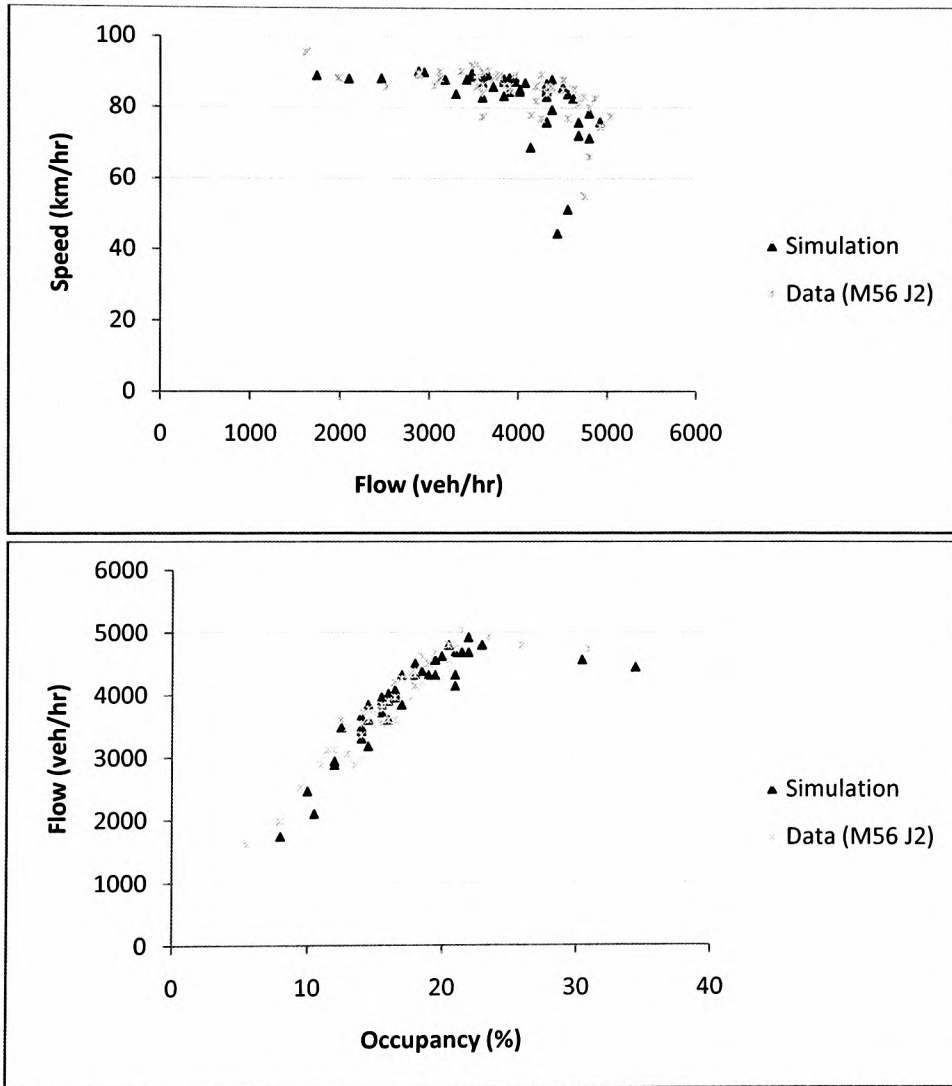

Figure 6-30 Actual and simulated speed-flow and flow-occupancy relationships

**6.5.2. Comparison with M62 J11 data**

This site consists of a one-lane on-ramp merging with a 3-lane motorway section. As in the M56 J2 site, there are many loop detectors located upstream and downstream of the

merge section as well as on the ramp, as shown in Figure 6-31. One data set was used for a period of four hours on the morning of 7/6/2010. The inputs and the analyses were averaged for every 5 minute interval. Data from U2 and the ramp detectors are used as an input as shown in Figure 6-32. The data from the other loops (i.e. U1, D1 and D2) are used for the purpose of comparison with the simulation results.

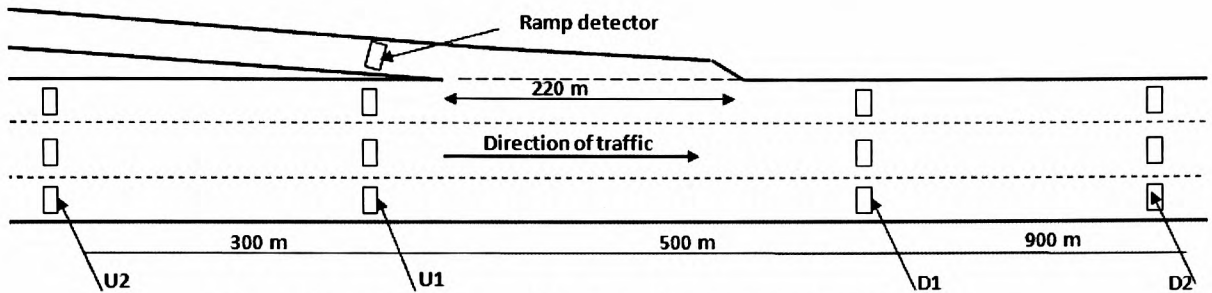

Figure 6-31 Locations of the loop detectors at the M62 J11

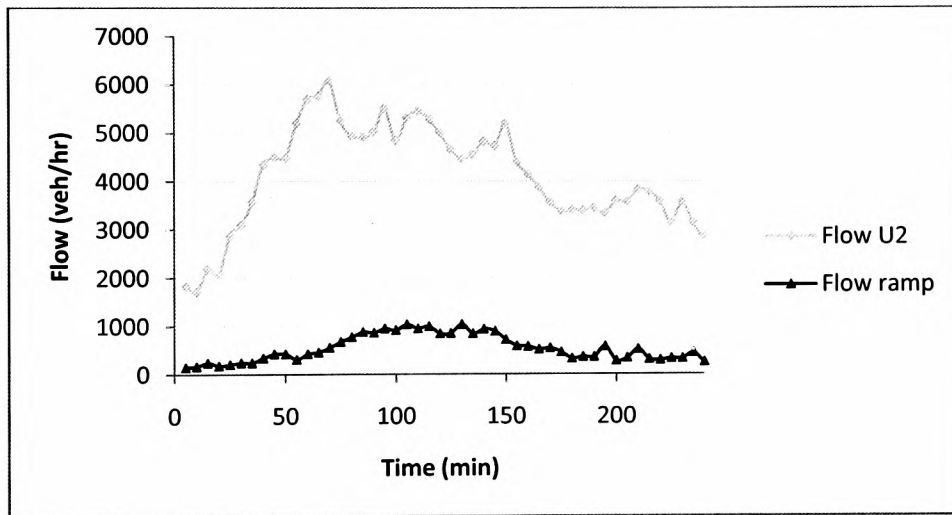

Figure 6-32 Actual input flow for the motorway and ramp sections at the M62 J11

The comparisons between the simulation and the real data are presented in Figure 6-33 using flow and speed parameters for detectors' station D1 and travel time for the whole section length. It should be noted here that the drop in speeds at time 110 minutes maybe due to a short period of speed limit enforcement which was started at location close to D2 (based on the position of the gantry). In the simulation, a speed limit value of 40 mph (56 km/hr) is applied for a period of 5 minutes and at the same location (i.e. close to D2). Figure 6-34 compares the actual and the simulated lane utilisation coefficients for detectors' stations U1, D1 and D2 and these suggest good agreement. The travel time here is estimated for each time interval using Equation 6-10 (Vanajakshi, 2004).

$$T.T = \sum_{i=1}^n \frac{st_{i+1} - st_i}{0.5(V_{i+1} + V_i)} \tag{Equation 6-10}$$

where,

$n$  is the number of loop detectors on the main motorway,  
 $st_i$  and  $V_i$  are the station (m) and the average speed (m/sec) at  $i$  loop detectors' station,  
 $st_{i+1}$  and  $V_{i+1}$  are the station and the average speed at  $i+1$  loop detectors' station, and  
 $T.T$  is the travel time at each time interval (sec).

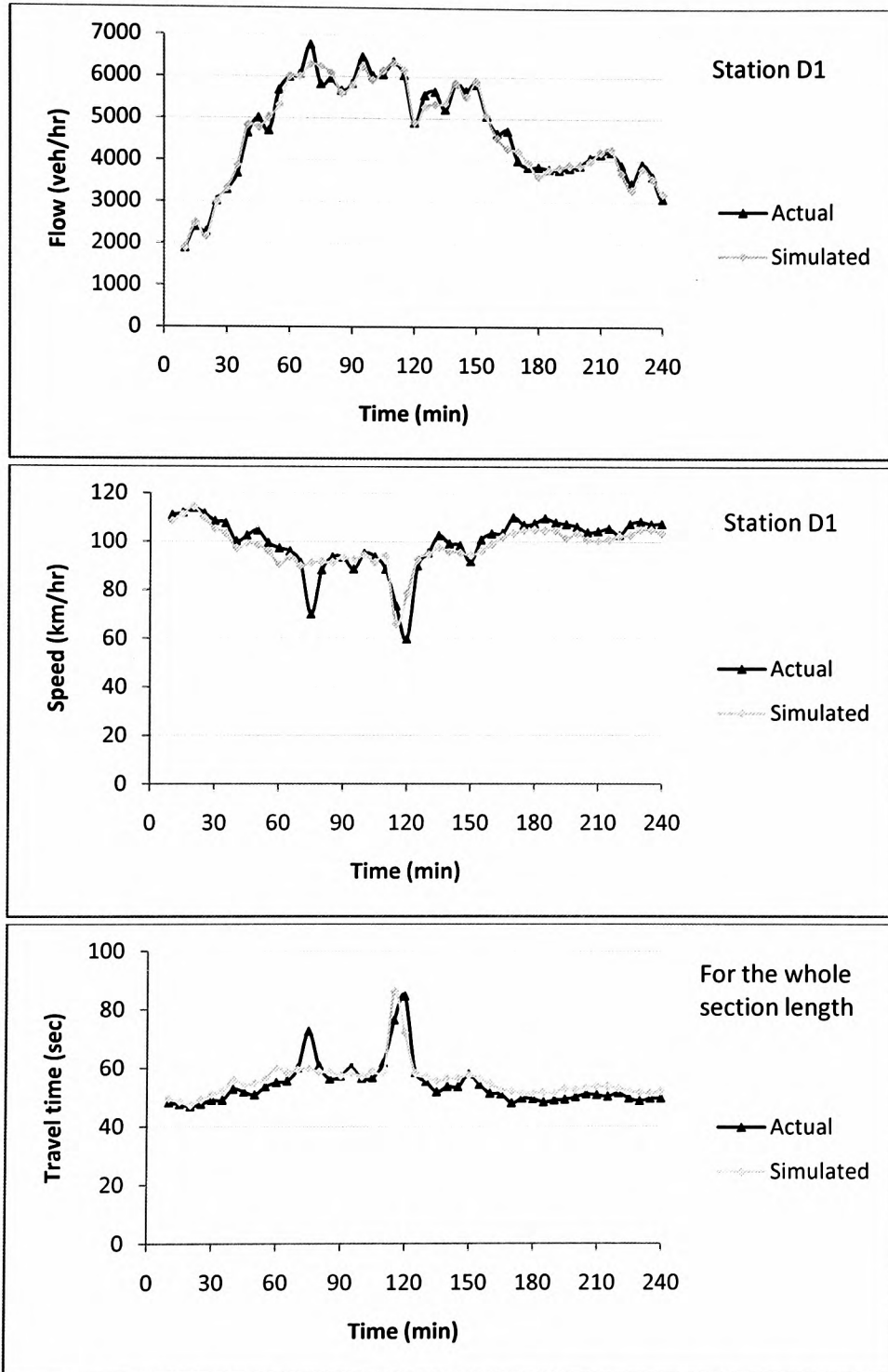

Figure 6-33 Actual and simulated flow, speed and travel time for the M62 J11



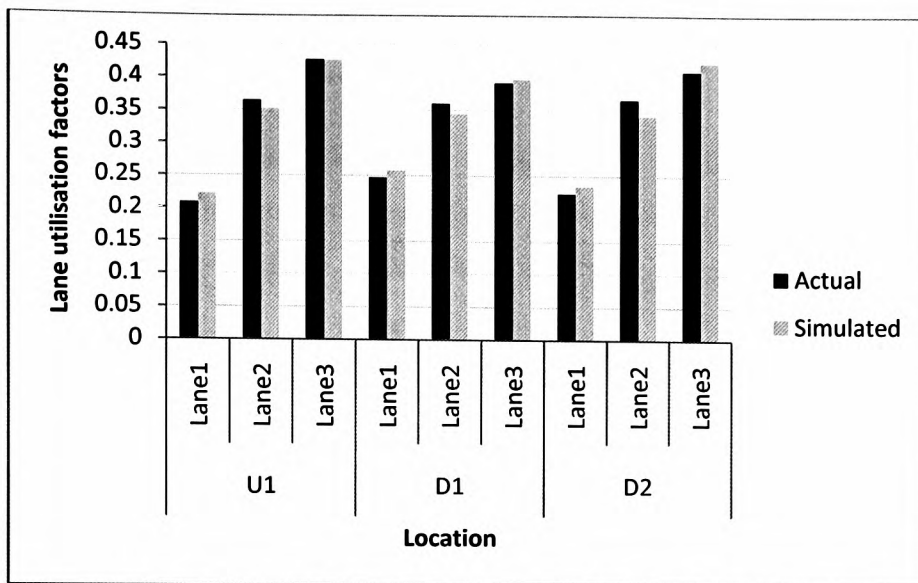

Figure 6-34 Actual and simulated lane utilisation factors for the M62 J11

The statistical test results are presented in Table 6-7 which, in general, suggests the validity of the model. The U and U\* values are acceptable (according to Brockfeld *et al.*, 2005) for all the considered factors (i.e. flow, speed, occupancy and travel time). The maximum value for RMSEP based on the flow calculations for all the detectors stations was only 5%. The statistics from the travel time measurements (from station U2 to station D2) indicate good agreement between the simulated and the observed travel time.

Table 6-7 Statistical tests for the developed model based on data from the M62 J11

Detectors' Station	Lane	RMSE	RMSEP (%)	r	Theil's inequality coefficient			
					U	U*	Um	Us
U1	Flow	166 (veh/hr)	4	0.99	0.02	0.04	0.17	0.04
	Speed	7.1 (km/hr)	13.2	0.75	0.04	0.07	0.05	0.26
D1	Flow	182 (veh/hr)	3.8	0.988	0.02	0.04	0.03	0.01
	Speed	5.4 (km/hr)	7.3	0.88	0.03	0.05	0.08	0.26
	Occupancy	1.4 (%)	12.8	0.88	0.06	0.11	0.03	0.0
D2	Flow	233 (veh/hr)	5	0.981	0.02	0.05	0.02	0.01
	Speed	5.0 (km/hr)	5.8	0.91	0.02	0.05	0.11	0.03
	Occupancy	1.39 (%)	9.9	0.91	0.05	0.11	0.17	0.20
	Travel time	3.8 (sec)	6	0.88	0.03	0.07	0.14	0.11

### 6.5.3. Comparison with M6 J20 data

This site consists of a 2-lane on-ramp merging with a 4-lane motorway section (see Figure 6-35). The selected set of data represents a period of 10 hours on 28/4/2009. Average five minute flow rates data were taken from the detectors' station U1 as well as from the ramp detectors and are used for the inputs (see Figure 6-36). The data taken from



the other detectors' stations D1, D2 and D3 are used for comparison with the simulation results.

Figure 6-37 compares the simulated flow, speed, and occupancy with the real data at detectors' station D1. The real data in the figure shows a sudden drop in the speed which may have happened due to many reasons such as the occurrence of an accident or the operating of a speed limit. The comparison for the lane utilisation factors for all the detectors' stations are shown in Figure 6-38 and provides good agreement between the simulated and the actual data. The statistical test results are presented in Table 6-8 which considers flow, speed, occupancy and travel time parameters. The results, in general, reveal good agreement between the simulated and the actual data (e.g. The RMSEP for the flow measurements did not exceed 5%).

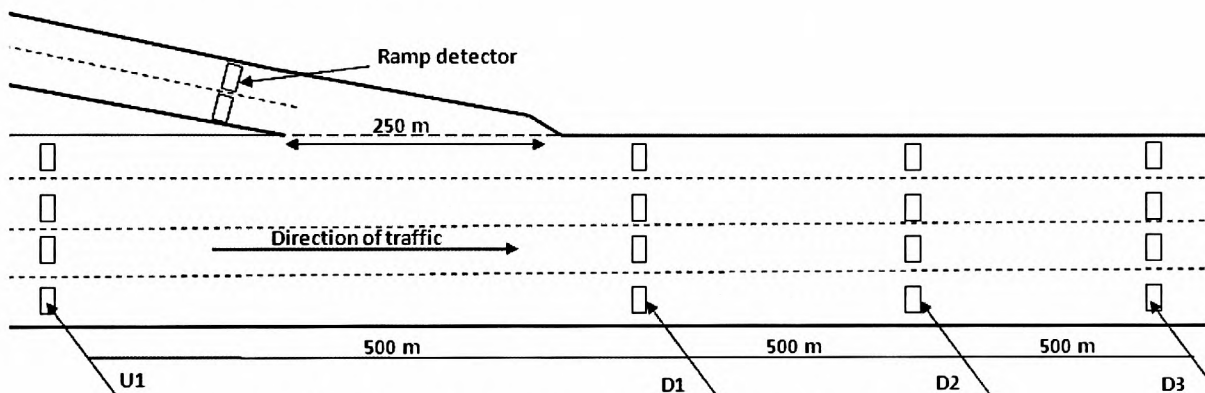

Figure 6-35 Locations of the loop detectors at the M6 J20

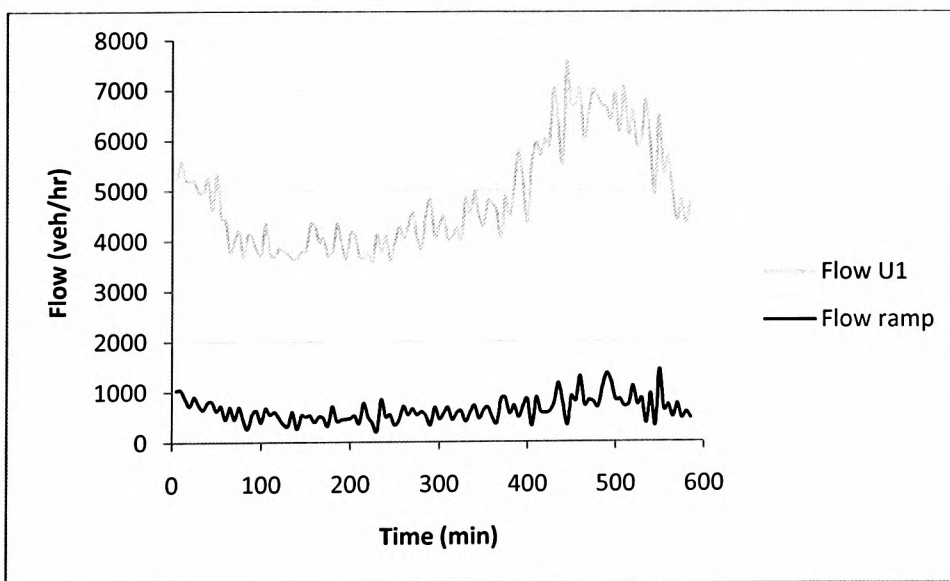

Figure 6-36 Actual input flow for the motorway and ramp sections at the M6 J20

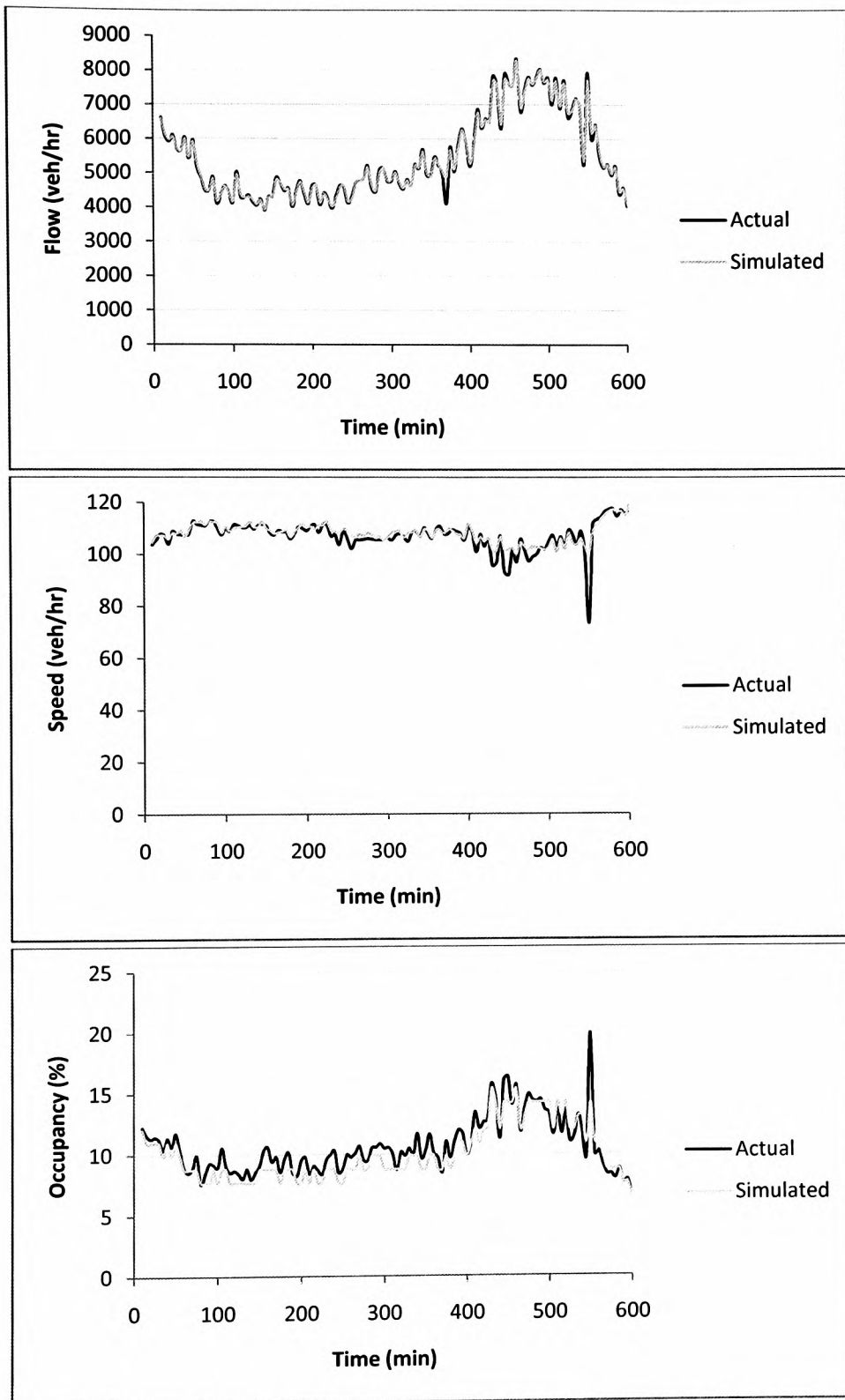

Figure 6-37 Actual and simulated flow, speed and occupancy at detectors' station D1

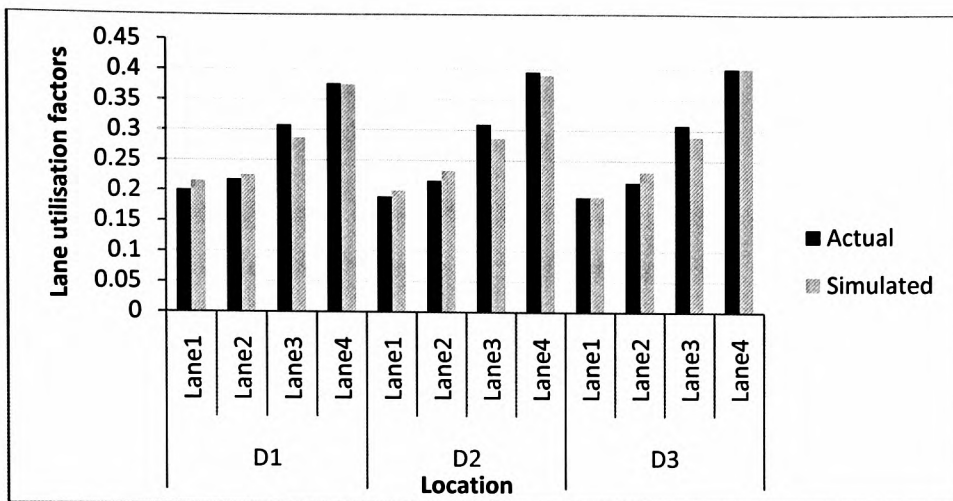

Figure 6-38 Actual and simulated lane utilisation factors for the M6 J20

Table 6-8 Statistical tests for the developed model based on data from the M6 J20

Detectors' Station	Lane	RMSE	RMSEP (%)	r	Theil's inequality coefficient			
					U	U*	Um	Us
D1	Flow	87 (veh/hr)	1.9	0.998	0.01	0.02	0.01	0.03
	Speed	2.0 (km/hr)	2.1	0.86	0.02	0.03	0.11	0.20
	Occupancy	0.93 (%)	8.9	0.917	0.05	0.01	0.28	0.02
D2	Flow	191 (veh/hr)	3.9	0.988	0.02	0.04	0.15	0.01
	Speed	2.2 (km/hr)	2.1	0.86	0.01	0.02	0.0	0.16
	Occupancy	1.0 (%)	10.8	0.91	0.05	0.10	0.26	0.12
D3	Flow	220 (veh/hr)	4.4	0.984	0.02	0.04	0.13	0.01
	Speed	3.5 (km/hr)	3.2	0.76	0.02	0.03	0.35	0.01
	Occupancy	1.1 (%)	10.9	0.9	0.05	0.11	0.13	0.20
	Travel time	0.83 (sec)	1.6	0.84	0.01	0.03	0.03	0.15

## 6.6. Comparison with S-Paramics' software

The S-Paramics model is widely used for traffic applications all around the world. This model is user friendly and is capable of dealing with relatively large networks as well as isolated sections. Two case studies were built using Paramics based on data from the M56 J2 and the M62 J11. The same inputs that were used in testing the newly developed model were used in testing Paramics. These two case studies were calibrated using various parameters such as the "mean time headway" and "the headway factor" in order to find the best results. For the other parameters which were not available, the default values in Paramics were used. Also, any built-in rules present in Paramics could not be changed (e.g. it is not possible to prevent HGVs from using the offside lane (Highway Code, 2010) and as observed at the sites. Furthermore, it is not possible for the user of Paramics to change certain input values such as the lane utilisation coefficients to exactly replicate real data.

The visual environment for Paramics revealed, when trying to replicate both data sets available from the M56 J2 and the M62 J11 sites, a high number of vehicles which had to stop at the end of the auxiliary lane before merging.

Table 6-9 shows a comparison between the RMSEP values obtained from both the developed simulation model and Paramics for different locations of traffic detectors at the M56 J2 and at the M62 J11 before and after the merge section. The results show that the RMSEP obtained from Paramics is much higher than those obtained from the developed model. This indicates that a great deal of care should be taken in selecting the default values when using Paramics to represent merging behaviour. Similar limitations in Paramics have also been reported by Sarvi and Kuwahara (2007).

Table 6-9 RMSEP (%) obtained from the model and from the S-Paramics model

Parameter	Simulation model	M56 J2			M62 J11		
		U1	D1	D2	U1	D1	D2
Flow (veh/hr)	S-Paramics	7.5	8.8	15.8	3.8	5.4	6.2
	Model-this study	2	2.9	2.7	4	3.8	5
Speed (km/hr)	S-Paramics	14.1	27.4	47.7	34.4	19.6	19
	Model-this study	2.3	3.8	2.7	13.2	7.3	5.8

## 6.7. Summary

This chapter presented the verification, calibration and validation of the car following, lane changing and merging rules as well as the validation of the whole simulation model using real traffic data. The results showed the validity of the model assumptions and therefore the model can be reasonably applied in testing the effect of different scenarios on the traffic conditions at merge sections. The next two chapters (Chapters 7 and 8) show the model applications that have been conducted.

## CHAPTER SEVEN : MODEL APPLICATIONS (WITHOUT THE USE OF RAMP METERING)

### 7.1. Introduction

This chapter presents the applications that have been conducted using the developed simulation model including testing the effect of heavy goods vehicles (HGVs) on merging capacity, estimating the HGVs' passenger car equivalency and testing the effect of cooperative behaviour. Some scenarios on enhancing traffic conditions within merging sections, such as the use of speed limits and lane changing restrictions, are also presented.

### 7.2. Effect of HGVs on capacity

#### 7.2.1. Background

Previous studies have suggested that the proportion of HGVs has a negative impact on capacity. This might be related to the following:

- HGVs are longer than cars and therefore the presence of HGVs will increase headways and hence reduce capacity.
- HGVs have lower acceleration rate abilities (ITE, 2010).
- HGVs have lower desired speeds than those of small cars (Yousif, 1993) and therefore drivers may avoid driving behind HGVs. This leads to increasing the headways and decreasing the capacity.

Hounsell and McDonald (1992) investigated factors affecting merge sections' capacity and concluded that every 1% of HGVs results in a 75 veh/hr reduction in capacity for a motorway section with three lanes (equivalent to 25 veh/hr per lane). Sarvi and Kuwahara (2007) reported that the effect of a 1% increase in HGVs on a two-lane motorway reduces the capacity of the merge section by about 15 veh/hr per lane.

#### 7.2.2. Methodology

To investigate the effect of HGVs on motorway capacity (prior to the creation of traffic congestion) typical merge sections for motorways with 2 and 3 lanes with one merging lane are used in the simulation model (see Figure 7-1 for the model with three lanes). HGVs' percentages of 0, 5, 10, 15, 20, 25 and 30 are used for both motorway and merge traffic. Flow rates upstream the merge section ( $q_m$ ) of 2000-4000 and 4000-6000 veh/hr with an increment of 500 veh/hr have been used for sections with 2 and 3 lanes

respectively. For each specific motorway upstream flow ( $q_{in}$ ), different flow rates for merge traffic ( $q_{ramp}$ ) are used with an increment of 100 veh/hr in order to find the accurate flow rates that cause the onset of traffic congestion. One hour's simulation time is used for each ramp flow increment.



Figure 7-1 The geometry used in testing the effect of HGVs (snapshot from the model)

Figure 7-2 shows an example of the process for estimating a capacity value for a 3-lane motorway with  $q_{in}$  of 5000 veh/hr and 15% of HGVs. The figure shows that the motorway could allow up to 1000 veh/hr to merge from a slip road before the onset of traffic congestion. Once the merge traffic exceeds this value, the created congestion will reduce both the motorway downstream capacity and the upstream throughput. The reduction in capacity obtained in the downstream location was about 6% while the reduction in the upstream throughput is about 9%. These are in agreement with the findings reported by Hounsell and McDonald (1992).

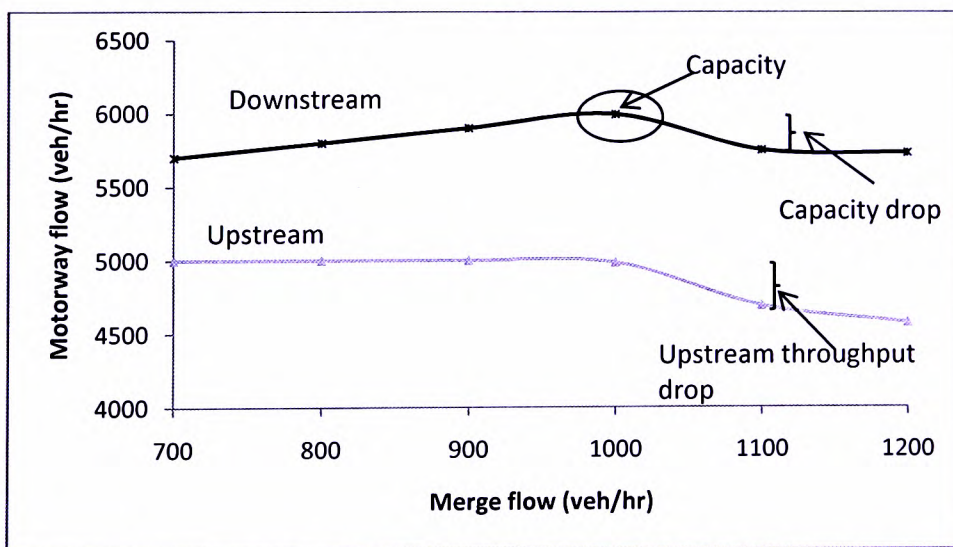

Figure 7-2 Estimation of the capacity value for  $q_{in}=5000$  veh/hr with 15% HGVs

### 7.2.3. Results

For motorway sections with 2 and 3 lanes respectively, Figure 7-3 and Figure 7-4 show the effect of HGVs' proportion as well as the upstream  $q_{in}$  on the maximum flows that could merge from a slip road prior to the onset of traffic congestion (i.e. merging capacity,  $Q_r$ ).



The figures show that the merging capacity ( $Q_r$ ) decreases with increasing the proportion of the HGVs and increases with the decreasing of the motorway upstream flow ( $q_{in}$ ).

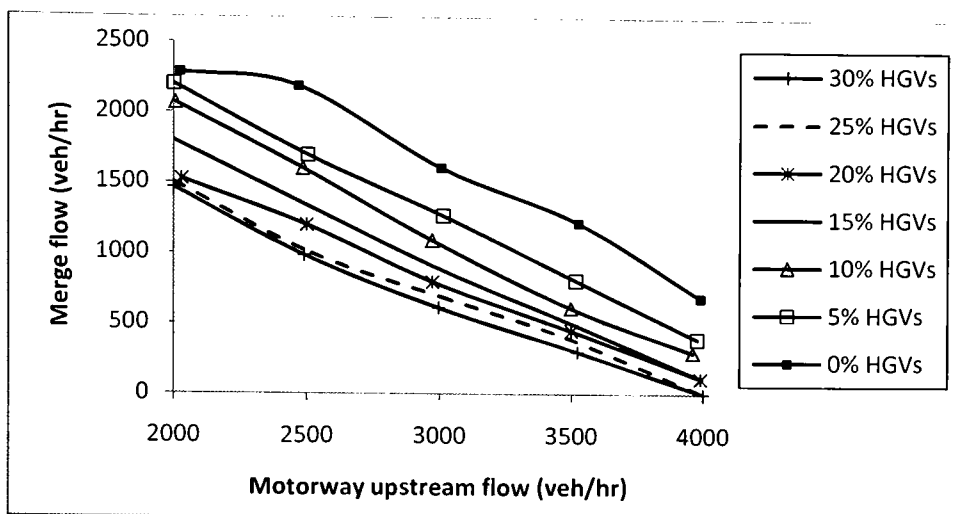

Figure 7-3 Maximum merge traffic prior to occurrence of congestion for a 2-lane section

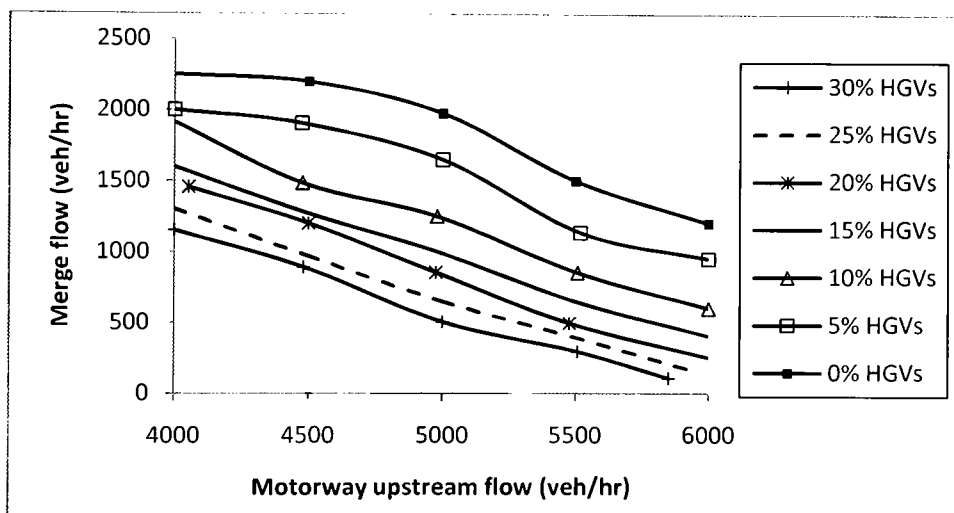

Figure 7-4 Maximum merge traffic prior to occurrence of congestion for a 3-lane section

Regression equations were developed from these simulation results for motorway sections with 2 and 3 lanes respectively, as respectively shown in Equations 7-1 and 7-2.

$$Q_r = 3884 - 0.8q_{in} - 31HGVs\% \quad (r^2=0.985) \quad \text{Equation 7-1}$$

$$Q_r = 4800 - 0.595q_{in} - 67HGVs\%(1 - 0.013HGVs\%) \quad (r^2=0.987) \quad \text{Equation 7-2}$$

The sum of the  $q_{in}$  and  $Q_r$  could be used to produce the motorway capacity. It is worth noting that the simulated motorway capacity ( $Q_r+q_{in}$ ) for 2-lane sections was compared with real traffic data obtained from Sarvi and Kuwahara (2007) as shown in Figure 7-5. The upstream flow ( $q_{in}$ ) of 2500 veh/hr was used when applying Equation 7-1 as presented in the source of the data. The figure suggests reasonable agreement between the model and the real data for such flow.

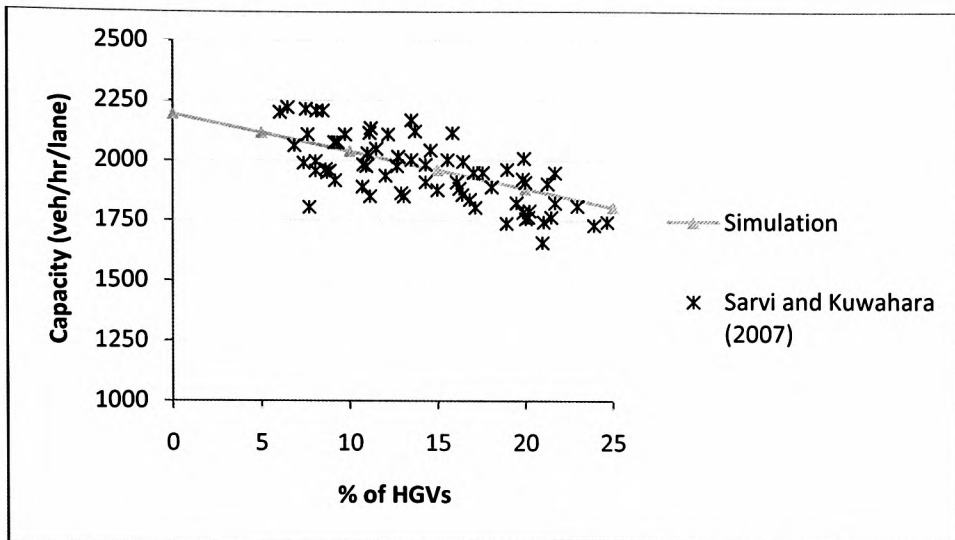

Figure 7-5 Simulated and actual capacity with respect to the percentage of HGVs for a 2-lane section

#### 7.2.4. Estimation of HGVs' equivalency factor

The figures and equations presented above showing the effect of HGVs on capacity are only valid for those cases where the percentages of HGVs in merge traffic are similar to those for motorway traffic. Extending the results for different proportions of HGVS needs an extensive number of simulation runs (more than 10,000 extra runs) and this is out of the scope of this study due to the time limitations. Therefore the easiest way to cover all cases is by converting the HGVs to passenger cars units (pcu) using the passenger car equivalency factor (PCE).

HCM (2010) applied Equation 7-3 to estimate the capacity based on the proportion of HGVs and the PCE factor and suggested a value of 1.5 for the PCE on any motorway section including merge and weaving sections. Hounsell and McDonald (1992) applied Equation 7-3 and suggested a PCE value of 2.5 with capacity ( $q_0$ ) of 7000 pcu/hr. Webster and Elefteriadou (1999) used the simulation technique and suggested that the PCE values vary with flow rates (free, normal and congested) and also with the proportion of HGVs. The latter study suggested that for traffic at capacity, the PCE values for a normal motorway section range from 1.5-2.0 based on the type of HGVs (i.e. semi-trailer, trailer, etc).

$$q = \frac{q_0}{1 + 0.01 \text{HGVs}\%(\text{PCE} - 1)} \quad \text{Equation 7-3}$$

where  $q$  is the flow rate at a given percentage of HGVs and  $q_0$  is the flow rate at zero percentage of HGVs.



The criteria adopted to find a PCE value is by selecting the value that gives similar capacities in passenger car units (pcu/hr) for different percentages of HGVs. Figure 7-6 suggests a value of 2.0 and revealed that using values lower than 2 underestimates the HGVs' effect while the use of higher values (greater than 2) will overestimate their effect.

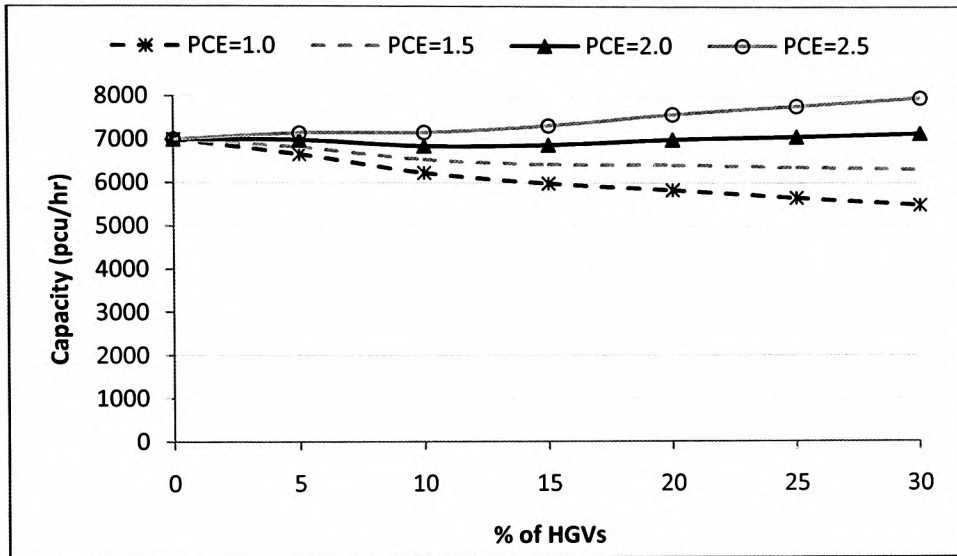

Figure 7-6 Capacity values in pcu/hr corresponding to PCE values

### 7.3. Effect of merge ratio on capacity

The above regression equations (Equations 7-1 and 7-2) suggest that for any proportion of HGVs, a capacity value measured downstream of the merge section decreases with increasing the “merge ratio”. Merge ratio here is defined as the ratio of merge flow to motorway downstream flow (Hounsell and McDonald, 1992). Figure 7-7 shows the simulation results for the effect of the merge ratio using a fixed proportion of HGVs of 15% for a motorway section with 3 lanes. Such an inverse effect of the merge ratio on the motorway capacity was found in real data according to Hounsell and McDonald (1992).

Such an effect for the merging ratio was not considered in the Highway Capacity Manual (2010) as it suggested that the capacity of lanes 1 and 2 in a motorway merge section is about 4600 pcu/hr regardless of the amount of merge traffic. This negligible effect by the merge ratio might be related to the relatively higher number of lanes on USA freeways compared to those in the UK motorways. Such higher number of lanes may help drivers on lanes 1 and 2 from shifting to other lanes when approaching merge sections and hence reduce the interactions happen between motorway and merge traffic.

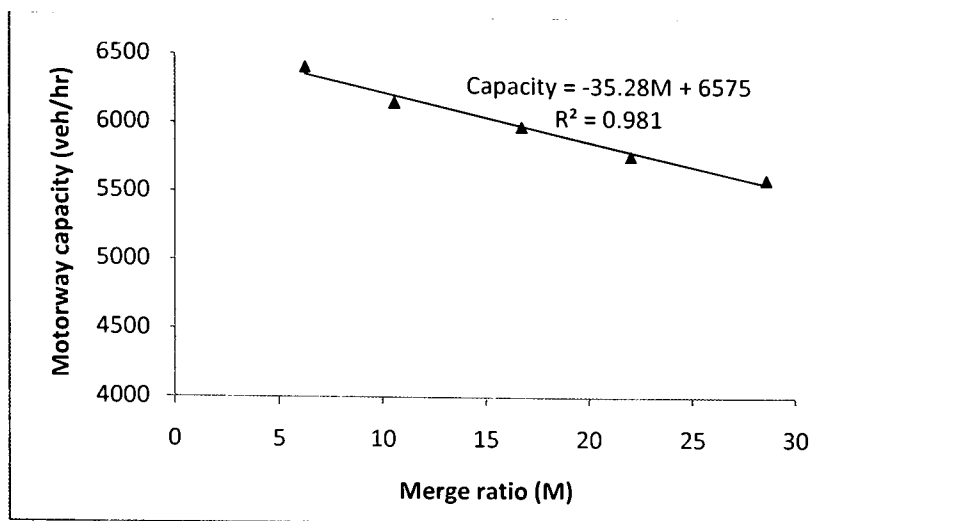

Figure 7-7 Effect of merge ratio on downstream capacity for a section with 3 lanes

#### 7.4. Effect of cooperative behaviour

The effect of the cooperative behaviour of motorway drivers (by decelerating in order to create safe gaps for merging traffic as discussed in section 5.9.2) has been investigated using the developed simulation model by considering the effect of such behaviour on the number of stopping cases before merging and on travel time.

A similar section to that presented in Figure 7-1 is used with a 150m length of auxiliary lane. Two levels of flow rates as shown in Table 7-1 are used with 5% proportion of HGVs.

Table 7-1 Flow levels used in testing the effect of cooperative behaviour

Flow level	$q_{in}$ (veh/hr)	$q_{ramp}$ (veh/hr)	%HGVs
1 (high)	5000	1000	5
2 (medium)	3000	1000	5

##### 7.4.1. Effect of cooperative behaviour on stopping cases

For flow level 1, Figure 7-8 shows that the higher the proportion of cooperative drivers the higher the percentages of cooperative cases (from all the merging cases) that occurred and hence the lower the number of cases where merging vehicles had to stop at the end of auxiliary lane before merging. This is because the cooperative behaviour increases the size of the available gaps and increases the probability of merging before reaching the end of the auxiliary lane. The percentages of cooperative cases (as shown in the Figure 7-8) are much lower than the proportion of cooperative drivers because not all the cooperative drivers face situations where they need to undertaken such cooperative behaviour.

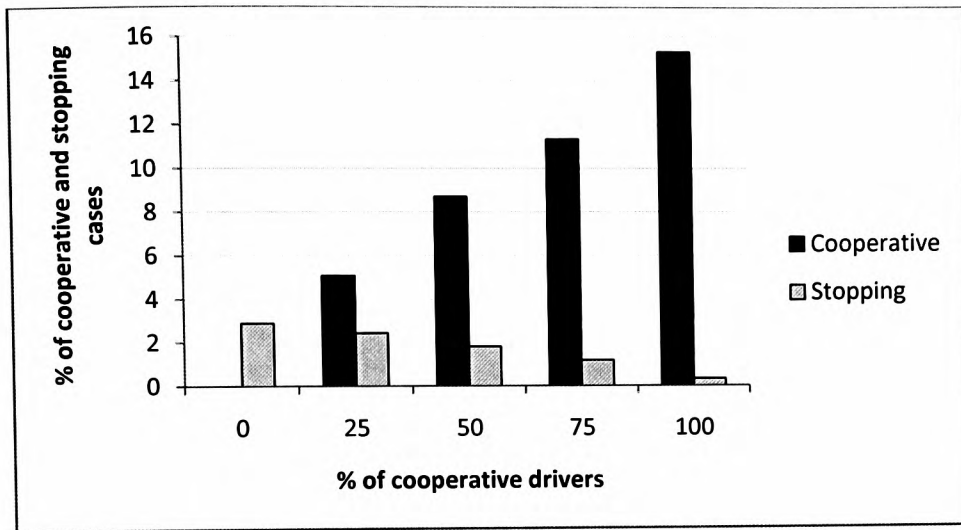

Figure 7-8 Effect of cooperative drivers on stopping and cooperative cases for flow level 1

For lower flow rates (level 2 in Table 7-1), the results in Figure 7-9 show a lower proportion of cooperative and stopping cases as compared with those in Figure 7-8. This is because the decrease in motorway flow rates produces larger gaps for merging traffic and hence reduces the need for cooperative behaviour.

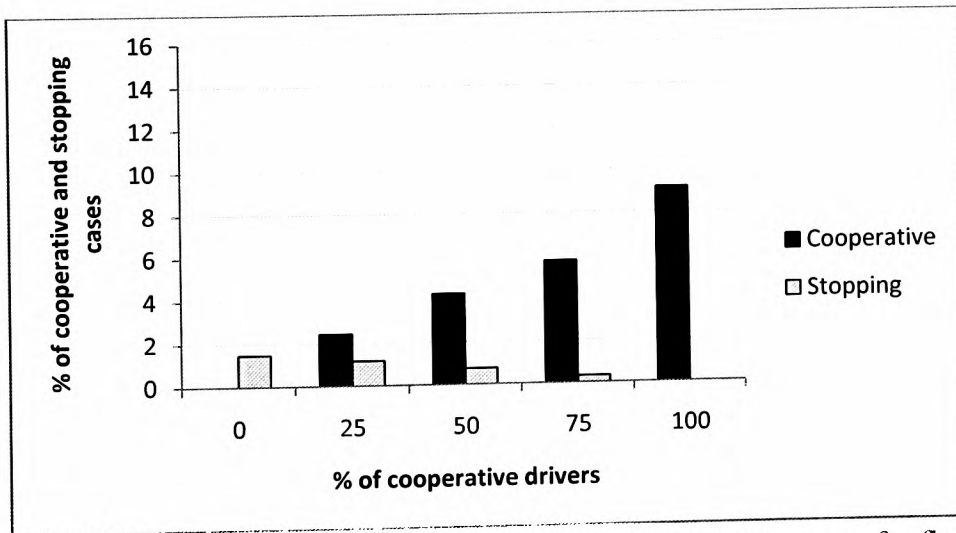

Figure 7-9 Effect of cooperative drivers on stopping and cooperative cases for flow level 2

**7.4.2. Effect of cooperative behaviour on travel time**

The total time spent (TTS) by traffic that uses a system is calculated as the sum of the total time spent for all vehicles on a motorway (TTSM) and on the ramp sections (TTSR). Here, the total time spent for merging traffic (TTSR) is the sum of the travel time measured from a ramp vehicle entering the system until it merges with other motorway traffic. The total time spent for motorway traffic (TTSM) is measured as the sum of travel time for motorway vehicles (from the start of the motorway section until leaving it) plus the travel time for those vehicles merging into a motorway system (from merging with

motorway traffic until leaving the motorway section). The time saving is obtained from Equation 7-4. Positive values obtained from the equation suggest a reduction in time spent while negative values suggest that the applied traffic control has inversely affected the traffic conditions.

$$\text{Time saving (\%)} = \frac{100[(\text{Time spent})_{\text{without coop.}} - (\text{Time spent})_{\text{with coop.}}]}{(\text{Time spent})_{\text{without coop.}}} \quad \text{Equation 7-4}$$

Figure 7-10 (for flow level 1) shows that an increase in the proportion of cooperative drivers could increase the time saving for both motorway and merging traffic (i.e. reducing the time spent when compared with a zero percentage of cooperative behaviour). The reduction in the time spent for merging traffic is expected because cooperative behaviour will make the merging process easier as it increases the size of available gaps due to cooperative behaviour. Although cooperative behaviour means that motorway traffic will reduce speed in order to help merging traffic, the results obtained from the simulation model suggest that the TTSM is also reduced. This also could be explained by a reduction in the cases of merging from stopping conditions (as presented in Figure 7-8) which will inversely affect motorway traffic conditions.

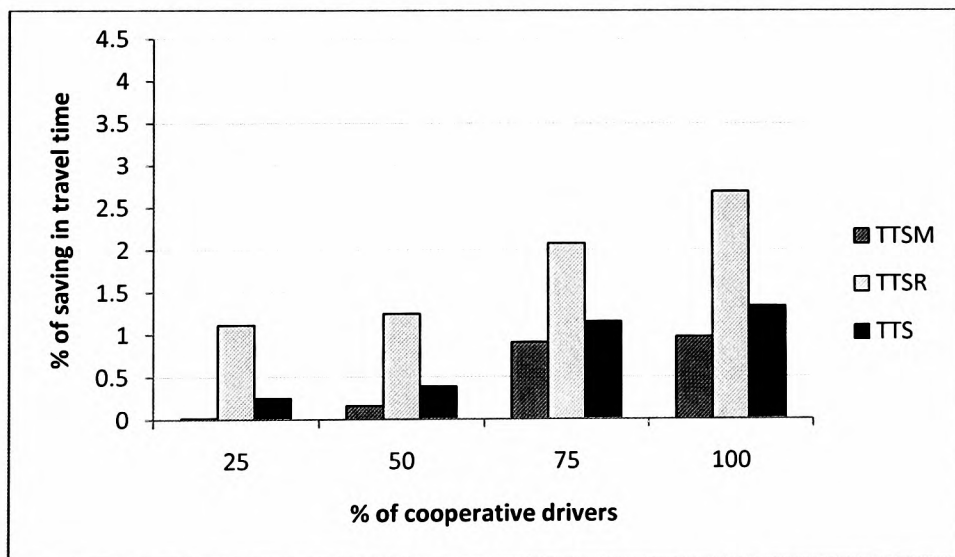

Figure 7-10 Effect of cooperative drivers on travel time for flow level 1

The effect of cooperative behaviour is minimal on travel time for flow level 2 as shown in Figure 7-11. This could also be explained by the reduction of cooperative cases at free flow conditions as a result of having enough space to merge without the need for such cooperative behaviour.

These findings are in disagreement with the simulation study by Liu and Hyman (2008) who suggested that cooperative behaviour caused an increase in the travel time for both

motorway and merging traffic. Liu and Hyman (2008) concluded that their findings were not as they expected and explained that random cooperative behaviour may have some interference with the merging process and thus causes further delay for merging traffic. The results of Liu and Hyman (2008) were based on applying the simulation model by Wang (2006).

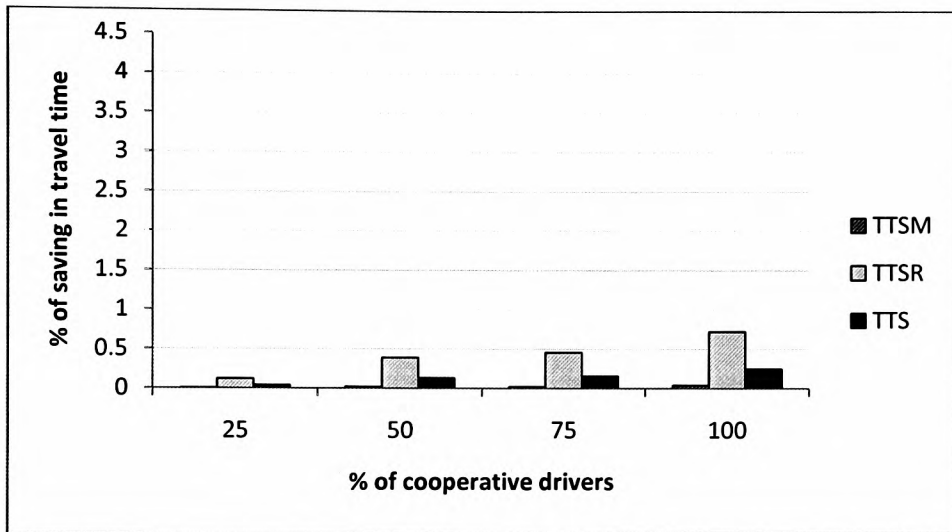

Figure 7-11 Effect of cooperative drivers on travel time for flow level 2

The effect of the auxiliary lane length on the benefit obtained from cooperative behaviour has also been tested and the results are shown in Figure 7-12, assuming that 100% of drivers are cooperative.

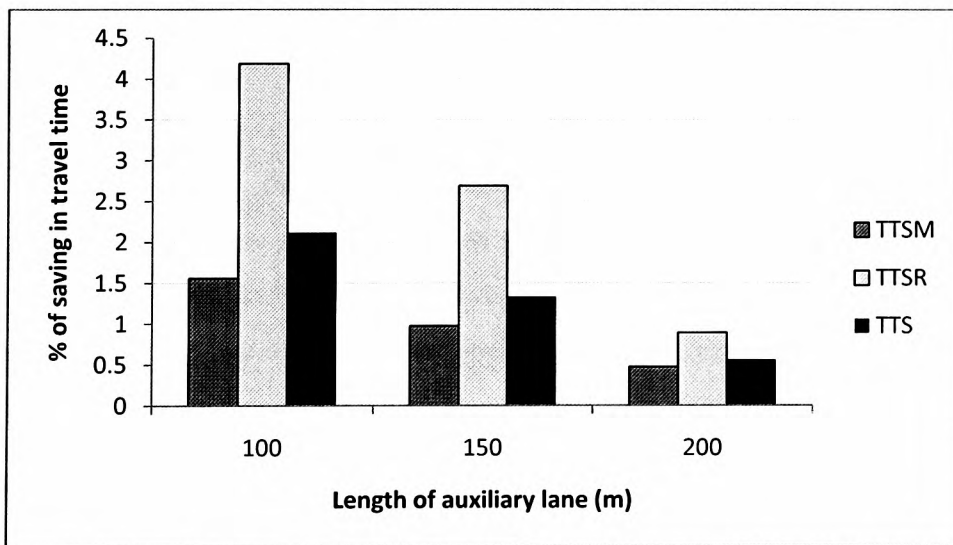

Figure 7-12 Effect of the length of the auxiliary lane on the time saving obtained from cooperative behaviour

The figure shows that the longer the auxiliary lane is, the lower the effect of cooperative behaviour. This is related to the ability of drivers to adjust their speeds with respect to the available lead and lag gaps if there is a relatively long auxiliary lane. Such adjustment will

reduce the need for vehicles to stop at the end of the auxiliary lane even where there is no cooperative behaviour received from motorway drivers.

## **7.5. Management of merge sections without the use of RM**

This section describes the effect of applying some traffic management controls without the use of RM. For this purpose, speed limits and lane changing restrictions (LCR) at the approach to merge sections have been used.

### **7.5.1. Effect of speed limits**

In testing the effect of speed limits, three values of 70, 80 and 90 km/hr have been individually applied for the whole simulation period (i.e. without giving attention to operating the speed limit signs based on traffic conditions as used in practice) and compared with the case of “without” speed limit. The distance that is covered by the speed restrictions includes the distance from 300m upstream to 100m after the end of the merge section. It is assumed that all drivers are compliant with the imposed speed limit. The main reasons for this assumption are:

- At high flow rates approaching the capacity, even non-complaint drivers (at free following) are forced to drive at the prevailing speeds (i.e. non-complaint will be less).
- Lack of compliant data with speed limits of 70, 80 and 90 km/hr.
- The testing of the effect of lower speed limits is a theoretical one to examine their relative effects.

In approaching the speed limit section, faster drivers are assumed to apply normal deceleration rates in order to match the speed limit. Flow rates of 1000 and 5000 veh/hr are respectively used for merging and motorway traffic to represent total flows at capacity. A typical HGVs' percentage of 15% is used for the motorway and merge traffic.

The simulation results for the scenario of “without” speed limit gave some variations due to different random numbers' seeds when traffic congestion was occurred in some of the simulation runs. The average results for the cases of with and without speed limit controls for six different seeds are presented in Figure 7-13 and Figure 7-14. The figures show the effect of speed limits on the time spent and on the upstream throughput, respectively. Both of these figures suggest that the use of a speed limit value of 90 km/hr is more appropriate than that of 70 and 80 km/hr values since the time spent was lower. Compared with the

“without” speed limit scenario, the 90 km/hr speed limit value has reduced the total time spent (TTS) by about 4% (see Figure 7-13). In all of the simulation runs, speed limit values of 70 and 80 km/hr caused traffic congestion making the traffic condition worse than the “without” speed limit scenario. The capacity was slightly increased by about 0.2% with the 90 km/hr value while the capacity was significantly reduced when using 70 and 80 km/hr values as shown in Figure 7-14.

The results in Figure 7-13 suggest that the TTSR is not affected by applying such speed limit controls and also suggest that the variation in TTS values is mainly because the effect of these speed limit controls on TTSM.

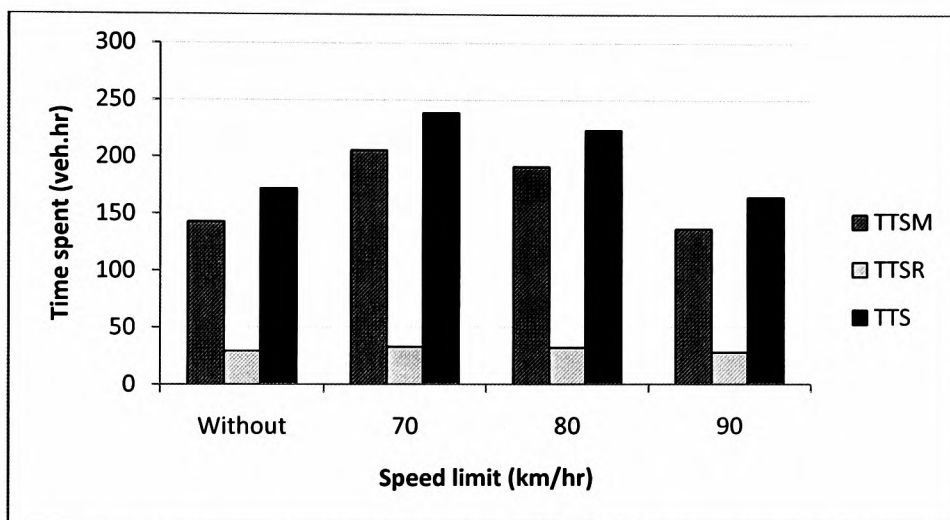

Figure 7-13 Effect of speed limit on time spent

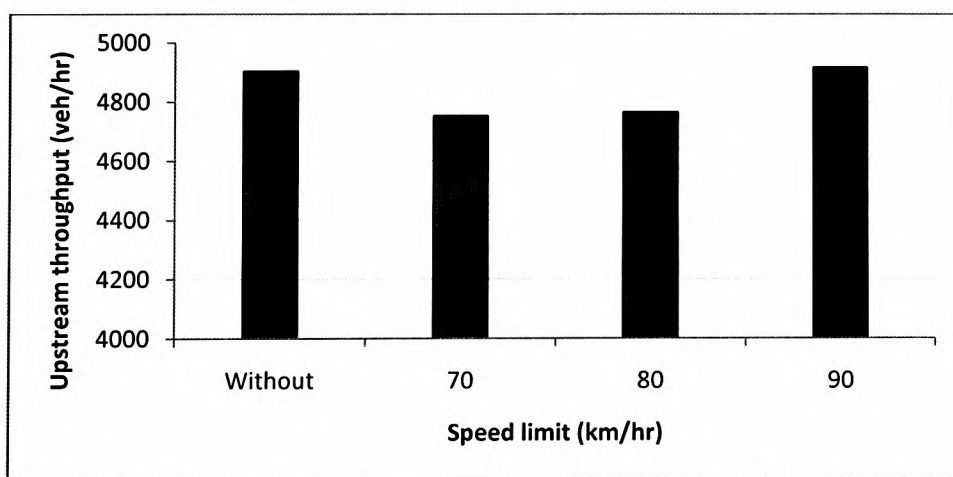

Figure 7-14 Effect of speed limit on motorway upstream throughput

To explain why 80 km/hr or lower speed limit values produced a negative effect, it is useful to discuss the case of traffic operation close to capacity (i.e. with 1000 veh/hr for merge traffic) and without any speed controls. Figure 7-15 shows the speed profile for motorway lanes 1, 2 and 3 and also shows the average speed across these three lanes. As



shown in the figure, the average speed just upstream of the merge section (at station 1500 m) for lanes 2 and 3 are 87 and 95 km/hr respectively which are higher than 80 km/hr. By imposing a speed limit of 80 km/hr for all lanes, this will inversely affect traffic operations in lanes 2 and 3. This discussion is supported by Heydecker and Addison (2011) who reported that for the M25 motorway (with 4 lanes), the use of 50 mph (equivalent to 80 km/hr) as a speed limit will inversely affect the capacity of lanes 3 and 4 of the motorway (see section 3.5).

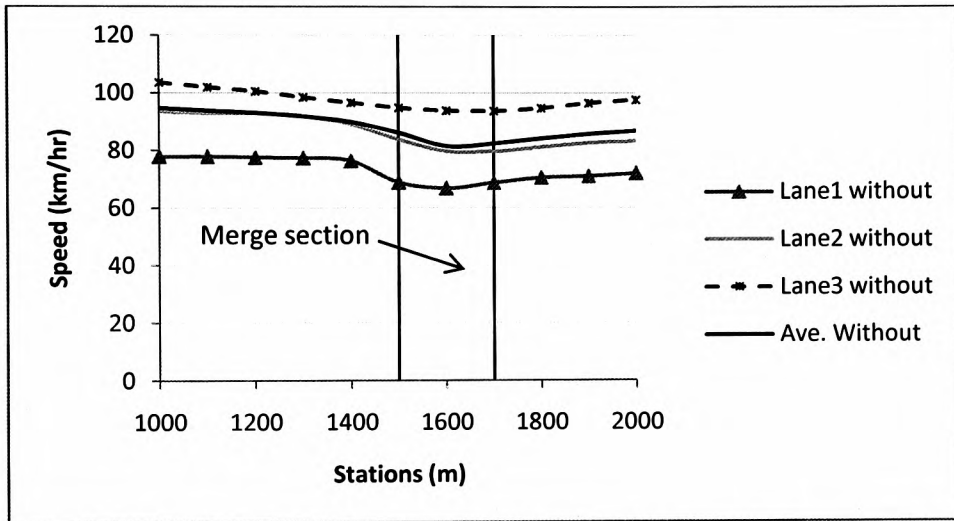

Figure 7-15 Speed profile for motorway lanes without using of speed limits

**7.5.2. Effect of Lane Changing Restrictions (LCR)**

The effect of LCR “Stay in Lane” at merge sections has been examined by using the following two scenarios:

- “Scenario 1” which is applied by allowing drivers in the nearside lane to move into the middle lane when possible, while restricting lane changes between the middle and the offside lanes within the section. This is to reduce the effect of the existence of the merge section on the capacity of lane 3 on the motorway section. For safety considerations and to prevent the speed of the third lane from being much higher than those in lanes 1 and 2, speed limit control of 80 km/hr is applied to the third lane once congestion starts in lanes 1 and 2.
- “Scenario 2” which prevents lane changes for all lanes in the motorway section.

For “Scenario 1”, different values for the lengths for the LCR section (see Figure 7-16) are used as shown in Equation 1-5 below.

$$\text{LCR section} = X + \text{Length of the auxiliary lane} + 100\text{m} \qquad \text{Equation 7-5}$$



where  $X$  (with values of 0, 100, 200 and 300 m) is the distance upstream of the merge section presented in Figure 7-16.

The optimum  $X$  value obtained from testing of “Scenario 1” has been applied to the testing of “Scenario 2” Flow rates of 1000 and 5000 veh/hr, which are similar to those rates used in testing the effect of speed limit controls, have been used for merge and motorway flow rates, respectively.

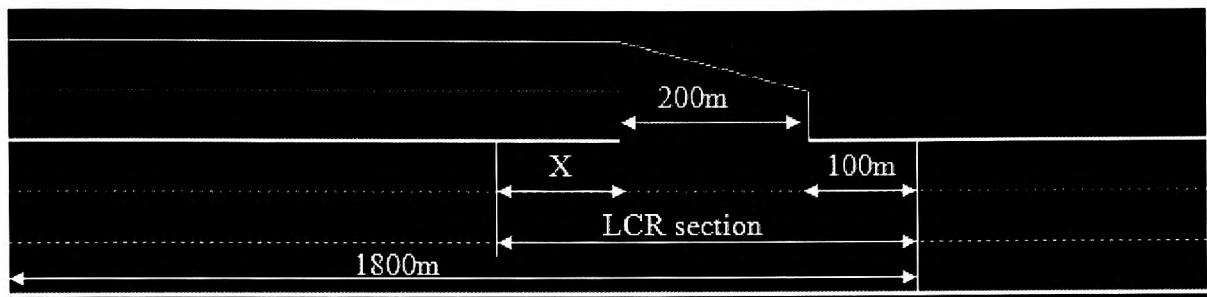

Figure 7-16 LCR section

Figure 7-17 shows the TTS values obtained from “Scenario 1” with different  $X$  values, the case of “without” control as well as the case of applying a “speed limit” control of 90 km/hr. The results suggest significant improvements which are achieved by using LCR with  $X$  values of 0 and 100 m. The TTS value was 16% lower than the TTS value obtained from the “without” control case. Similar to that discussed in section 7.5.1 when considering the effect of speed limit controls, Figure 7-17 shows that the TTSR is not affected by applying LCR and suggests that the variation in TTS values is mainly due to the effect of these LCR on TTSM.

For “Scenario 2”, The  $X$  value of 100m is used in the tests. Figure 7-18 shows the speed profile for motorway lanes 1, 2 and 3 and also shows the average speed across these three lanes. The figure suggests a significant reduction in speeds for the all lanes in the upstream section. This could be related by the occurring of congestion in the inside lane (i.e. lane 1 of a motorway section) with such high flow rates and due to preventing lane changes to the other lanes (i.e. to the right). Such a case would cause traffic congestion to occur in the other motorway lanes also (i.e. lanes 2 and 3) when the queues created on lane 1 are propagating upstream the LCR section and start shifting to the other right lanes.

Figure 7-19 compares the results obtained from applying “Scenario 2” with those results obtained from using of “Scenario 1” and also for cases of speed limit and “without” any controls. The figure suggests the LCR with “Scenario 2” was worst than all other cases since the time spent values were higher. Comparing with the case of “without” any

controls, the results in Figure 7-19 suggests that applying of “ Scenario 2” caused in increasing the travel time (i.e. increasing the delays) of both motorway and merge traffic and hence the overall travel time has also increased. The increasing in TTSM, TTSR and TTS were about 46%, 24% and 42%, respectively.

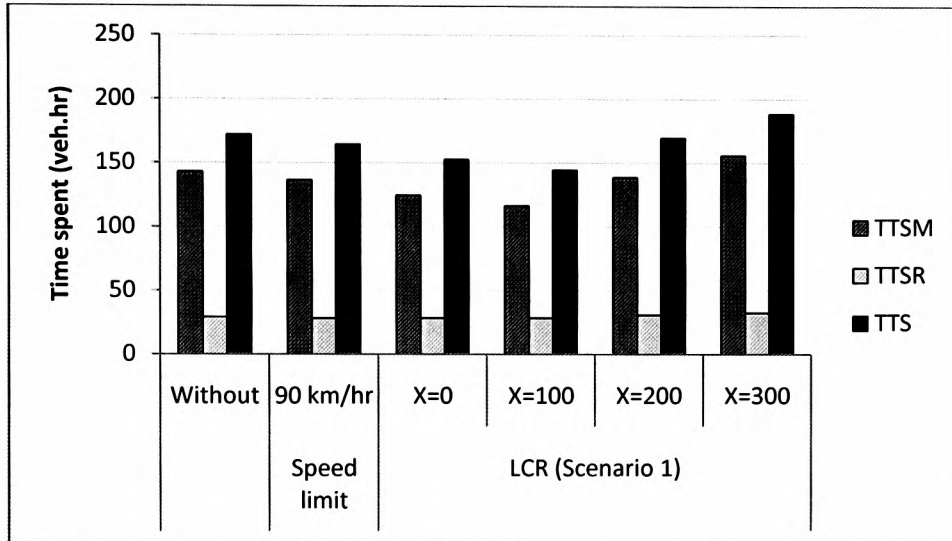

Figure 7-17 Time spent obtained from without control, speed limit and LCR (Scenario 1)

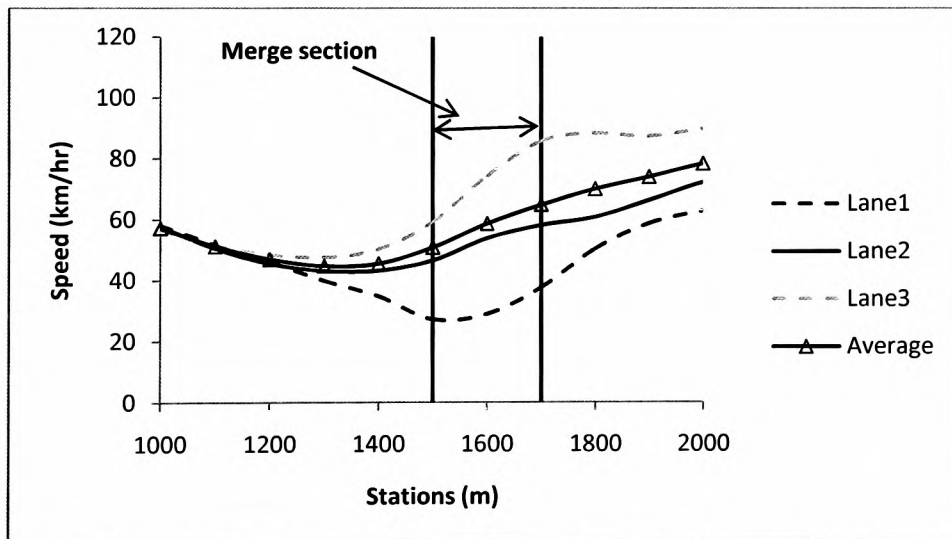

Figure 7-18 Effect of applying “Scenario 2” on the speed profile

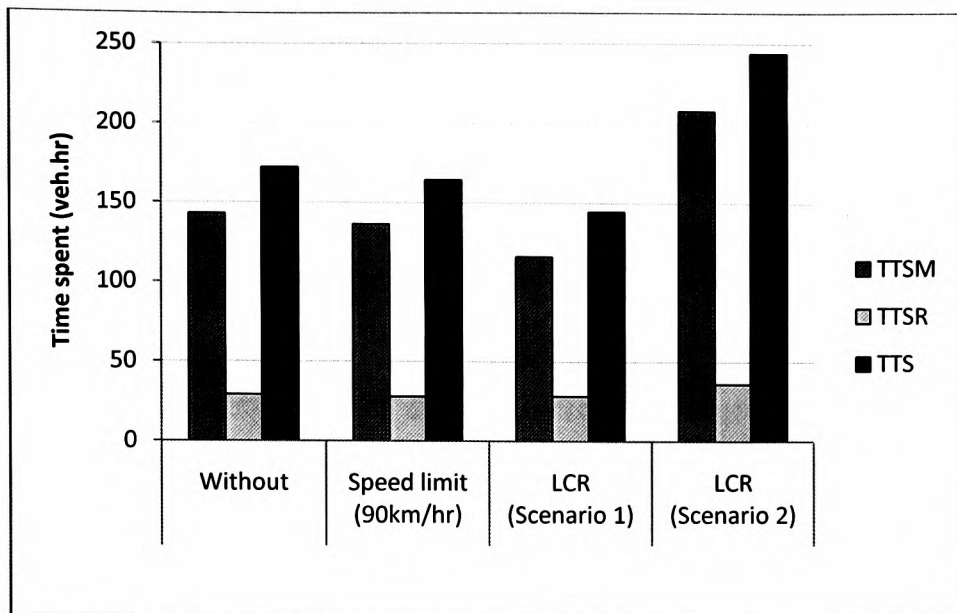

Figure 7-19 Time spent obtained from without control, speed limit and LCR

## 7.6. Summary

This chapter presents some applications that were conducted using the developed model including the testing of the effect of HGVs on the capacity of motorway merge sections with 2 and 3 lanes. Regression equations were developed from the simulation results. The HGVs' equivalency factors were estimated and a value of 2.0 was found suitable. Studying the effect of cooperative behaviour showed that higher proportions of cooperative drivers lower the need for merging traffic to stop at the end of the auxiliary lane.

The effects of applying some traffic management controls without the use of RM were tested including speed limits and lane changing restrictions (LCR). The simulation results suggested that the use of speed limits at a value of 80 km/hr (i.e. 50 mph) or lower may adversely affect traffic conditions for merge sections while using a value of 90 km/hr would slightly decrease the travel time. In addition, using LCR with fully preventing lane changes on all lanes at the approach to the merge sections may increase travel time for certain levels of flow rates. Allowing drivers on the nearside lane to move to the middle lane when possible, while restricting lane changes between the middle and the offside lanes within the merge section, has the ability to reduce the overall travel time for both motorway and merge traffic.

## CHAPTER EIGHT : MODEL APPLICATIONS (WITH RAMP METERING)

### 8.1. Introduction

The chapter presents the use of the developed simulation model to discuss some issues relating to ramp metering (RM). These issues include the estimation of the optimum parameters for some widely used RM algorithms, the effectiveness of RM algorithms, the effect of ramp length, the effect of having different peak periods on the effectiveness of RM, the effect of the position of traffic signals, the effect of changing the cycle length and testing some of the queue override strategies.

### 8.2. Optimum parameters of RM algorithms

#### 8.2.1. Introduction

This section describes the work which has been conducted in order to find the optimum parameters for some of the selected algorithms including ALINEA, D-C and ANCONA algorithms. The RMPS algorithm is already based on a similar logic to that used in ALINEA and therefore no further attention to this algorithm has been given.

#### 8.2.2. Methodology

##### a. *Selected section*

As shown in Figure 8-1, the geometry used in testing the different scenarios consists of a 3-lane motorway with a 2-lane on-ramp which has a length of 300m. The length of the auxiliary lane is 200m.

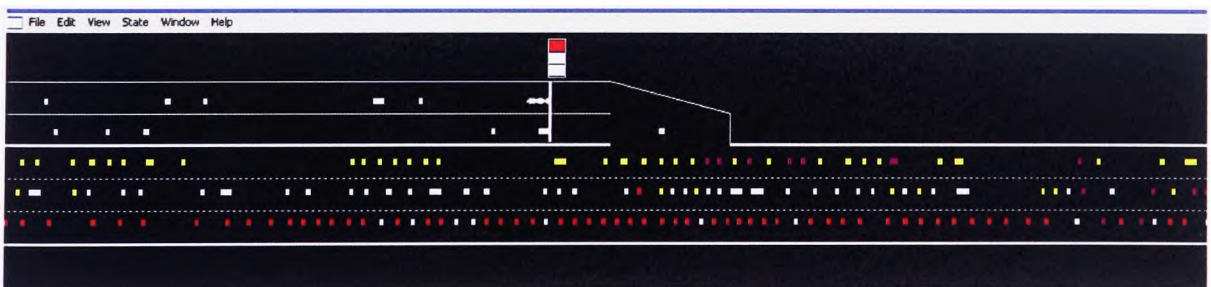

Figure 8-1 The geometry used in testing RM (snapshot from the model)

Warm-up and cool-off sections were selected as 500 and 1000m, respectively. The default value for the position of the main motorway upstream detectors is selected as being 100m upstream of the nose. The position of the queue override detectors (QOD) downstream of

the ramp entrance is taken as being, as recommended by the Highways Agency (2008), at 39m.

*b. Selected flow rates*

Previous research work has suggested wide ranges of RM parameters. For example and for the ALINEA algorithm, values of 17-30% were suggested for desired occupancy ( $O_{des}$ ) values. In addition, the optimum parameters may vary depending on flow levels. In order to deal with the optimum parameters properly and in order to minimise the required numbers of simulation runs, flow rates (as shown in Figure 8-2) have been used with a standard composition of heavy goods vehicles (HGVs' percentage) of 15%. This process, with such flow rates, has been regarded as a "primary optimisation process". The purpose of this process is to suggest a narrower range for each selected parameter. The suggested optimum parameter(s) will then be tested using different flow rates, as shown in Table 8-1 and with three different random numbers seeds.

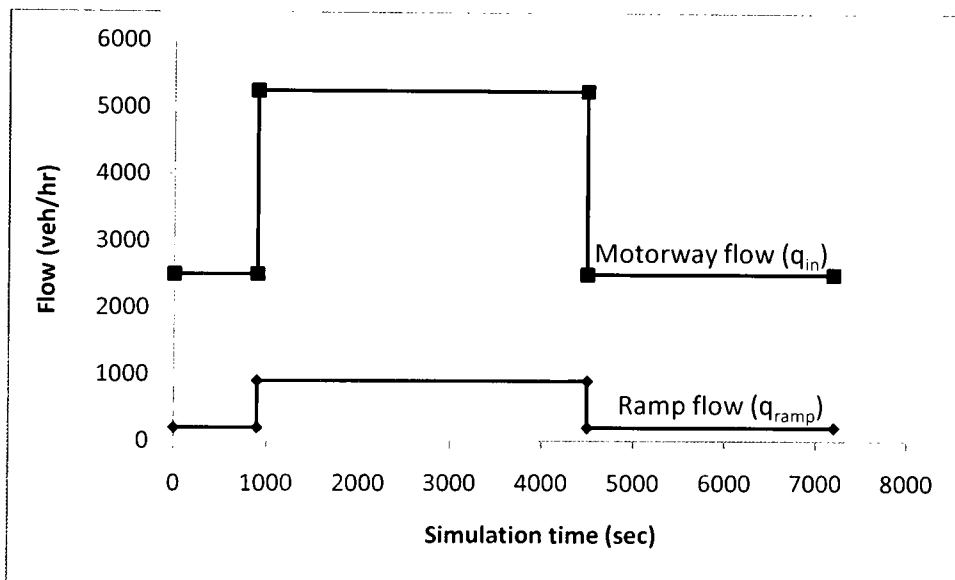

Figure 8-2 Selected input flows for simulation in the "primary optimisation process"

Table 8-1 Flows selected in finding the optimum parameters for RM algorithms

Motorway flow ( $q_{in}$ ) (veh/hr)	Ramp flow ( $q_{ramp}$ ) (veh/hr)				
	1000	1100	1200	1300	1400
5000	1000	1100	1200	1300	1400
5250	800	900	1000	1100	1200
5500	600	700	800	900	1000
5750	500	600	700	800	900

c. Queue override strategy (QOS)

Two techniques, as described by Gordon (1996) and Zheng (2003), have been applied in the simulation model in order to prevent the queue created on the ramp section from propagating upstream towards other networks. The model calculates the average occupancy at this location for each 15 seconds interval. When the estimated occupancy at the QOD (which is located 39m downstream from the ramp entrance) exceeds a value of 30%, the metering rate is increased to be a maximum of either 900 veh/hr or a value obtained from the RM logic. Once the calculated occupancy at the ramp entrance reaches a value of 50% or more, the override signal of 20 seconds green time (based on a cycle time of 30 seconds) is applied until the calculated occupancy is reduced to a value below 50%.

### 8.2.3. Results from selected RM algorithms

#### 8.2.3.1. ALINEA algorithm

Factors that are considered in optimising the ALINEA algorithm include  $O_{des}$  to trigger the signals and the position of downstream loop detectors on the main motorway lanes. The regulator parameter for the ALINEA algorithm ( $K_R$ ) is fixed at a value of 70 veh/hr, as suggested by Hadj-Salem and Papageorgiou (1991). The minimum and maximum metering rates are fixed at 400 and 1600 veh/hr as used by (Smaragdis and Papageorgiou, 2003). In testing the effects of individual factors, different values for each parameter were used (i.e. minimum-maximum, with incremental value, respectively) and the combinations of changing these differing values for each factor were analysed. Values of (17-30, 1%) are used for  $O_{des}$  with (0-700, 50m) being used for the position of the traffic detectors downstream of the nose.

a. Optimum position of downstream loop detectors with desired occupancy

Table 8-2 provides a summary of the optimum  $O_{des}$  for each selected position of the downstream loop detectors (on main motorway lanes). In general, the table suggests that  $O_{des}$  decreases with the increasing location of the loop detectors downstream of the nose. This could be interpreted as drivers in the vicinity of this area usually maintaining close following behaviour for a relatively short period of time and this results in getting higher occupancy values.

In estimating the optimum  $O_{des}$  at the optimum position for the traffic loop detectors, the results shown in Table 8-2 suggest a value of 23% at a location of 300m downstream of the

nose. The results are consistent with other studies (see for example Hasan *et al.* (2002) and Papageorgiou *et al.* (2008)) regarding the position of the bottleneck in merge sections. Since the position of loop detectors in the real situation is close to 300m downstream of the nose, a decision has been made to consider this location for further analysis in this study.

Table 8-2 Optimum  $O_{des}$  at each selected loop detectors' position

Detectors position (m)	Optimum $O_{des}$ (%)	TTSM (veh.hr)	TTSR (veh.hr)	TTS (veh.hr)	Upstream capacity (veh/hr)
0	30	236.372	76.025	312.399	5043
50	29	250.486	77.947	328.433	5007
100	29	245.894	77.632	323.527	5043
150	27	240.965	76.496	317.462	5006
200	27	247.791	77.96	325.752	5014
250	25	246.466	74.364	320.831	5061
<b>300</b>	<b>23</b>	<b>218.239</b>	<b>73.035</b>	<b>291.276</b>	<b>5119</b>
350	22	233.57	65.697	299.269	5077
400	20	248.188	76.809	324.997	5037
500	19	247.093	75.247	322.34	5013
600	19	254.52	60.525	315.046	4918
700	19	274.351	50.953	325.305	4901

For the selected optimum location of the downstream detectors (i.e. 300m), Figure 8-3 suggests that using 21-23% as  $O_{des}$  could provide a lower total time spent for motorway traffic (TTSM) and also a lower total time spent (TTS). The figure shows that the total time spent for ramp traffic (TTSR) decreases with increasing the  $O_{des}$  values. Figure 8-4 shows the effect of  $O_{des}$  on upstream speed and throughput and Figure 8-5 shows the effect of  $O_{des}$  on traffic delay. Both of these two figures suggest that the optimum  $O_{des}$  falls within the range of 21 to 23%. Figure 8-5 reveals that lower values of  $O_{des}$  give higher ramp traffic delays. The delay is considered as the difference between the simulated travel time and the travel time based on the desired speed of vehicles. Here, ramp delay is measured from a ramp vehicle enters the system until it merges with other motorway traffic. The overall delay represents the average weighted delay values for both motorway and merging traffic.

The explanation of the above findings is that higher  $O_{des}$  values will result in delaying the operation of RM and also results in the metering rate not being strict enough to recover normal traffic conditions according to the ALINEA algorithm. Using lower values for  $O_{des}$  will result in operation of the RM earlier and will reduce the metering rate. This will cause having longer queues on the ramp section and hence increase the need to operate the QOS



which will reduce the efficiency of RM. This discussion is supported by the results presented in Figure 8-6 which shows the effect of selective  $O_{des}$  values on the ramp queues created during the simulation period. The selection of optimum  $O_{des}$  should mainly be based on the TTS in the system. The selected value of 23% for  $O_{des}$  is similar to the critical occupancy value ( $O_{cr}$ ) that obtained from real data for the M6 J23 motorway with three lanes (see section 4.9.1) and that supports the use of  $O_{des}$  equal to  $O_{cr}$  in RM.

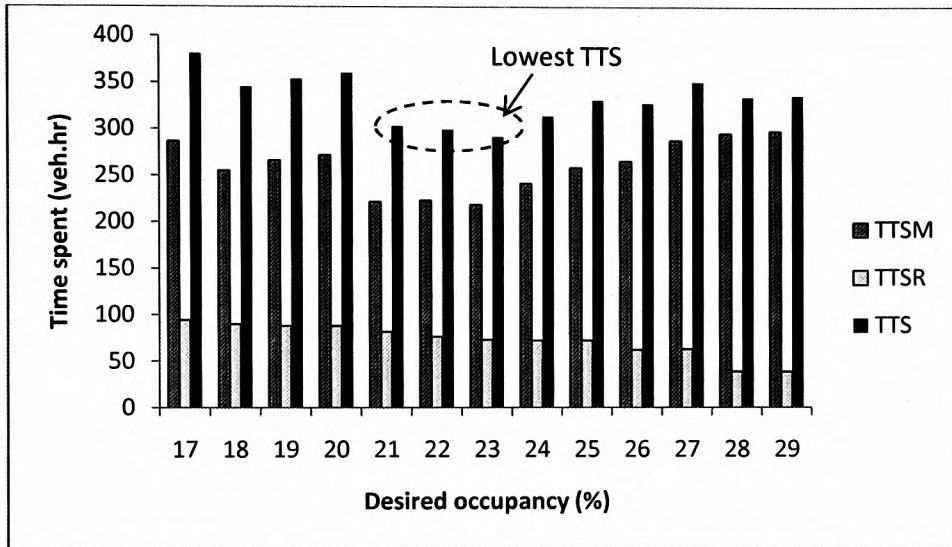

Figure 8-3 Effect of selected  $O_{des}$  time spent using ALINEA algorithm

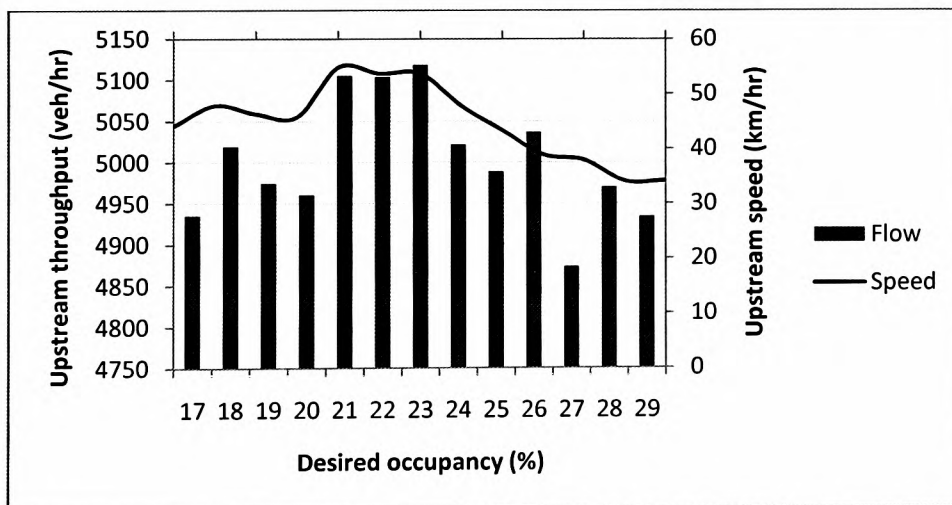

Figure 8-4 Effect of  $O_{des}$  on motorway throughput and speed using ALINEA algorithm



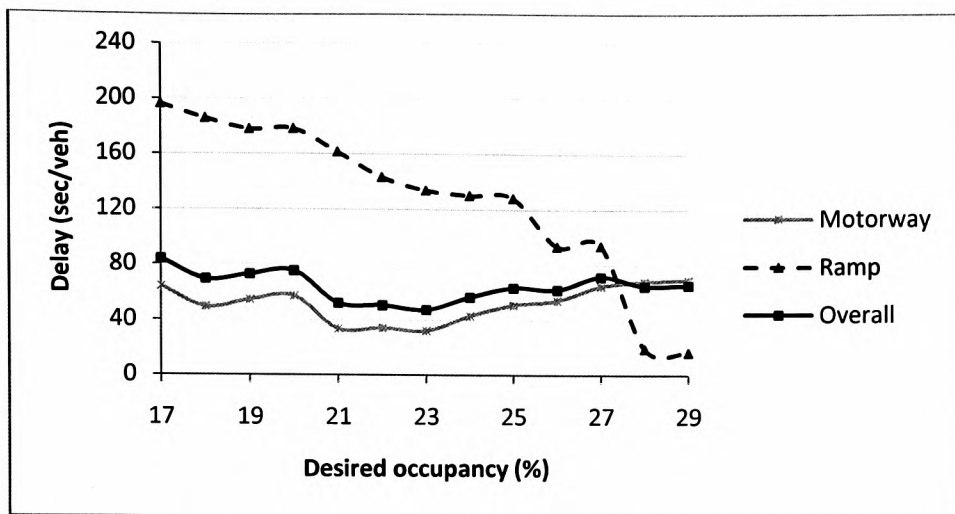

Figure 8-5 Effect of  $O_{des}$  on traffic delay using ALINEA algorithm

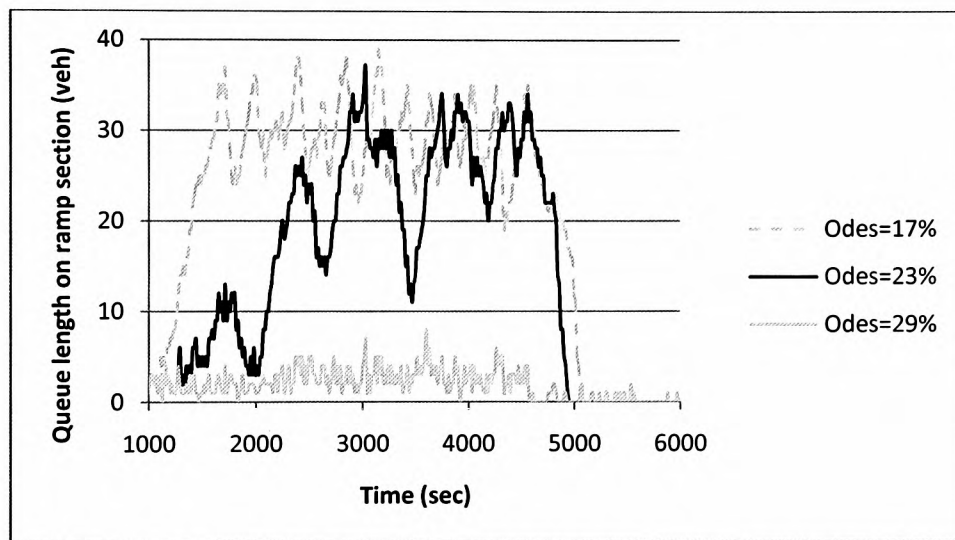

Figure 8-6 Effect of  $O_{des}$  on the ramp queue length using ALINEA algorithm

*b. Selection of desired occupancy based on wide ranges of flow rates*

The criteria adopted in section-a revealed that the selection of 23% as a  $O_{des}$  value corresponding to the position of the downstream detectors of 300m could provide better effectiveness in using the ALINEA RM algorithm. The validity of this selection has been confirmed by testing the effect of  $O_{des}$  values of 21-24% on TTS results using the flow rates given in Table 8-1. The lowest TTS values were obtained by using 23% as shown in Figure 8-7. The figure gives an example from the results by comparing the TTS values obtained from 21%, 22% and 24% values with those TTS results obtained from using a base value of 23%. Each point in Figure 8-7 represents the average of three simulation runs for a specific motorway and ramp flow rates from those given in Table 8-1.

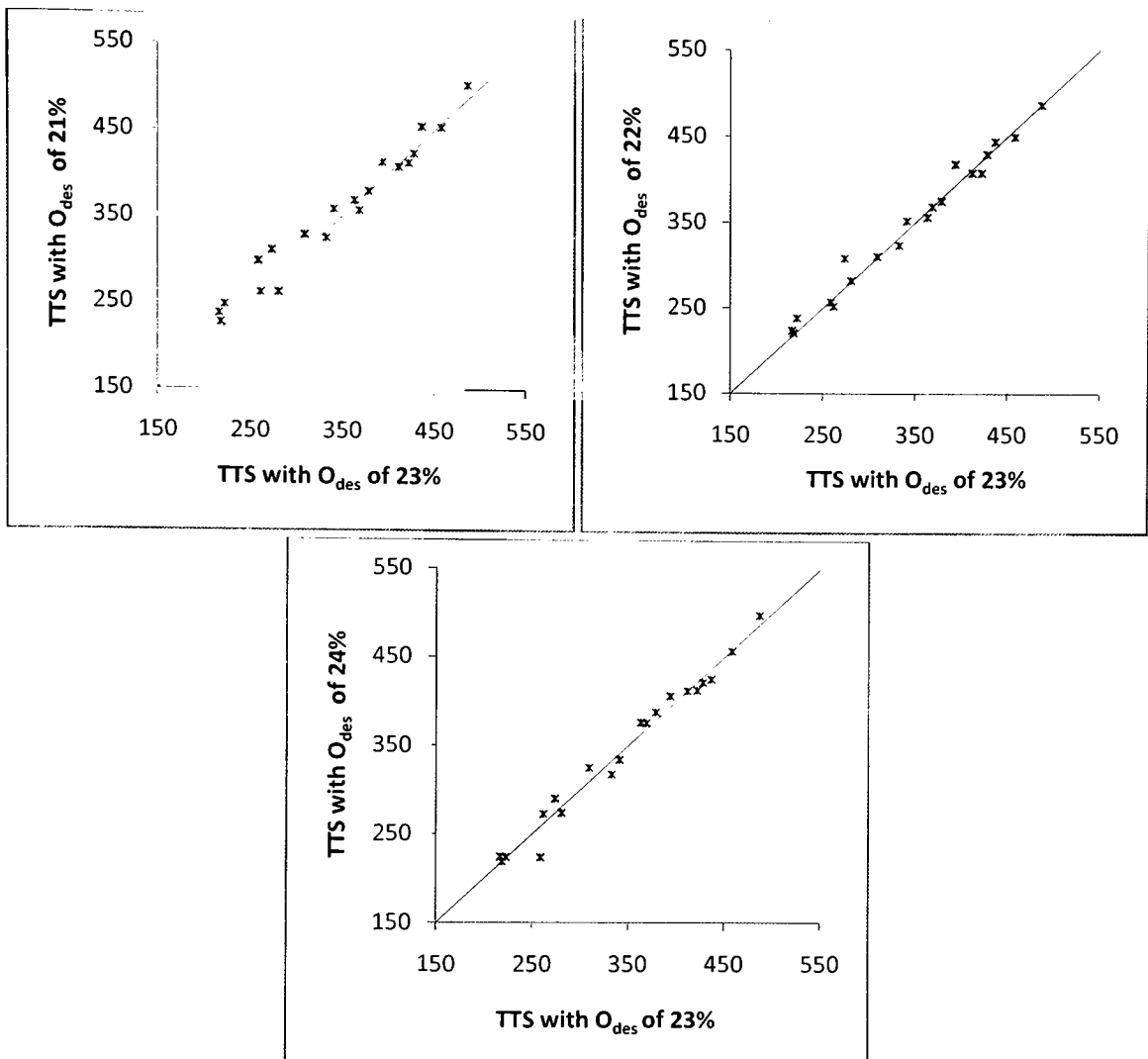

Figure 8-7 TTS obtained from the ALINEA with the flow rates given in Table 8-1

### 8.2.3.2. D-C algorithm

The same position of the downstream loop detectors of 300m as derived from using the ALINEA has been used to find the optimum  $O_{cr}$  for the D-C algorithm. A value of 6000 veh/hr is used for the motorway capacity. Similar values of minimum and maximum metering rates to those applied for the ALINEA algorithm have been used (i.e. 400 and 1600 veh/hr, respectively).  $O_{cr}$  values of 21%-26% have been tested with an increment of 1% by using the flow rates presented in Figure 8-2. Figure 8-8 and Figure 8-9 are respectively showing the effect of  $O_{cr}$  on the motorway throughput and the TTS. Both of these two figures suggest an optimum value of 23% which is identical to the  $O_{des}$  value obtained from using the ALINEA algorithm. Based on the wide ranges of flow rates, Figure 8-10 confirms the validity of the selection of 23% for  $O_{cr}$  by comparing the results of TTS obtained with 22%  $O_{cr}$  value.

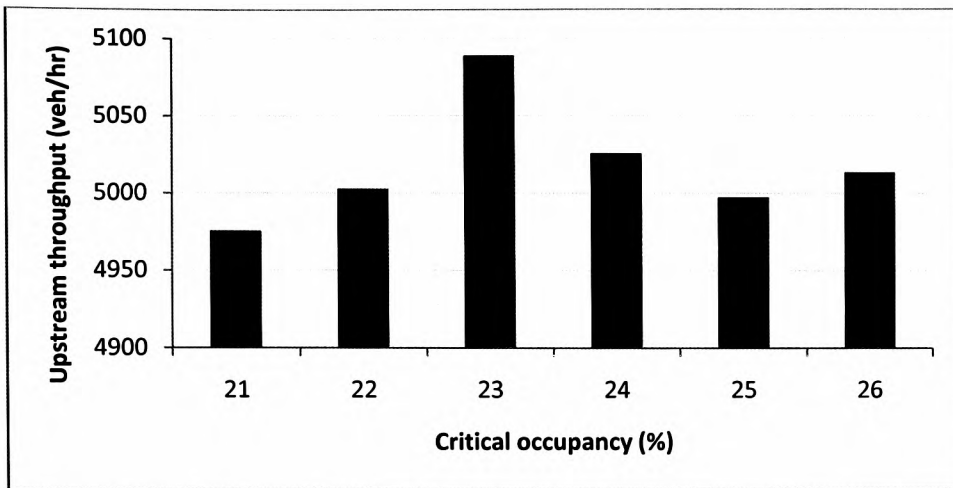

Figure 8-8 Effect of  $O_{cr}$  on upstream throughput using the D-C algorithm

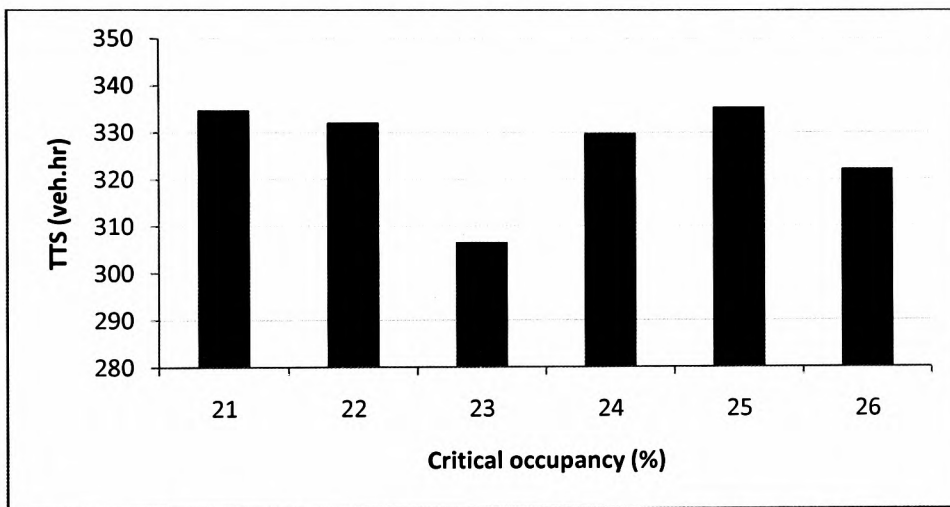

Figure 8-9 Effect of  $O_{cr}$  on TTS using the D-C algorithm

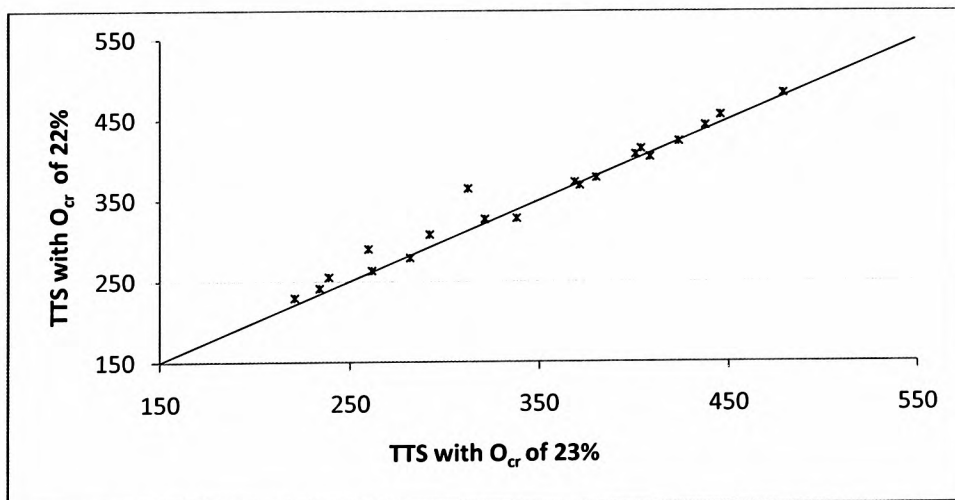

Figure 8-10 TTS obtained from the D-C algorithm with the flow rates given in Table 8-1

### 8.2.3.3. ANCONA algorithm

The ANCONA algorithm parameters are  $q_1$ ,  $q_2$ ,  $Sp_1$  and  $P$  (as mentioned in section 3.6.3). The value for  $q_1$ , representing the minimum metering rate, is fixed at 400 veh/hr (as used

by Smaragdis and Papageorgiou (2003)). The P value is a specific period of a continuous time interval which is used to determine when to turn off the RM signals in cases where the upstream motorway speed is continuously higher than Sp1. Since there is no specific criteria in determining the value of q<sub>2</sub> when using the ANCONA algorithm (as described in section 3.6.3), a fixed value of 900 veh/hr is used for the purpose of this work. However, this parameter should be selected carefully based upon site conditions (including, for example, a combination of ramp and motorway flow rates). The selected optimisation parameters are Sp1 and P. Sp1 values of 60, 65, 70 and 75 km/hr have been tested with P values of 3, 5 and 10 minutes using the flow rates presented in Figure 8-2. Figure 8-11 shows that using Sp1 values of 60-65 km/hr with P values of 5-10 minutes gives better results (i.e. lower TTS values).

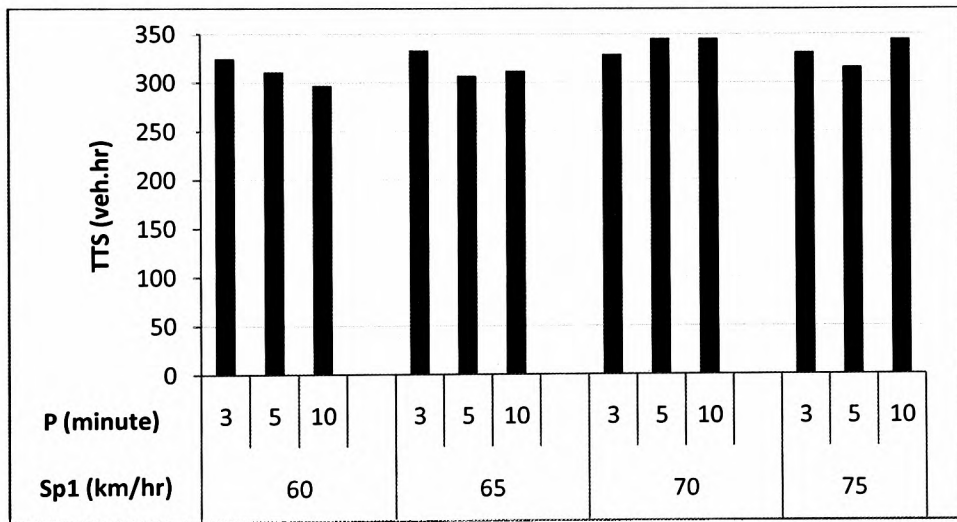

Figure 8-11 Effect of Sp1 and P parameters of the ANCONA algorithm

The simulation results revealed that using higher values for Sp1 (e.g. 70 km/hr) is not efficient in cases where there is no ultimate need to trigger the RM (i.e. when there is no traffic congestion). In addition, such higher values of Sp1 cause the RM to be operated sooner and increases the periods when the minimum metering rate (q<sub>1</sub>) is operated. That will cause longer queues on the ramp section and hence increase the need to operate the QOS and will reduce the efficiency of RM (similar to that discussed when looking at the ALINEA algorithm when using low O<sub>des</sub> values). The use of low values for the P (e.g. 3 minutes) may cause in allowing the stopped queues created upstream the signal from merging with motorway traffic and causing congestion.

Table 8-3 shows the combinations of Sp1 and P parameters which have been tested using the flow rates given in Table 8-1. A total of 5 tests have been used where values for Sp1 of 60 & 65 km/hr and P values of 5 & 10 minutes have been selected. Another test has been

conducted for Sp1 equal to 70 km/hr with P equals to 5 minutes for the reasons of comparison. The results obtained from 300 simulation runs (60 runs for each test) suggested values of 60 km/hr and 10 minutes for Sp1 and P, respectively (see Figure 8-12 which compares the TTS results for these five test by using test 2 as a base).

Table 8-3 The combinations of Sp1 and P used in optimisation of the ANCONA algorithm

Test No.	1	2	3	4	5
Sp1 (km/hr)	60	60	65	65	70
P (minute)	5	10	5	10	5

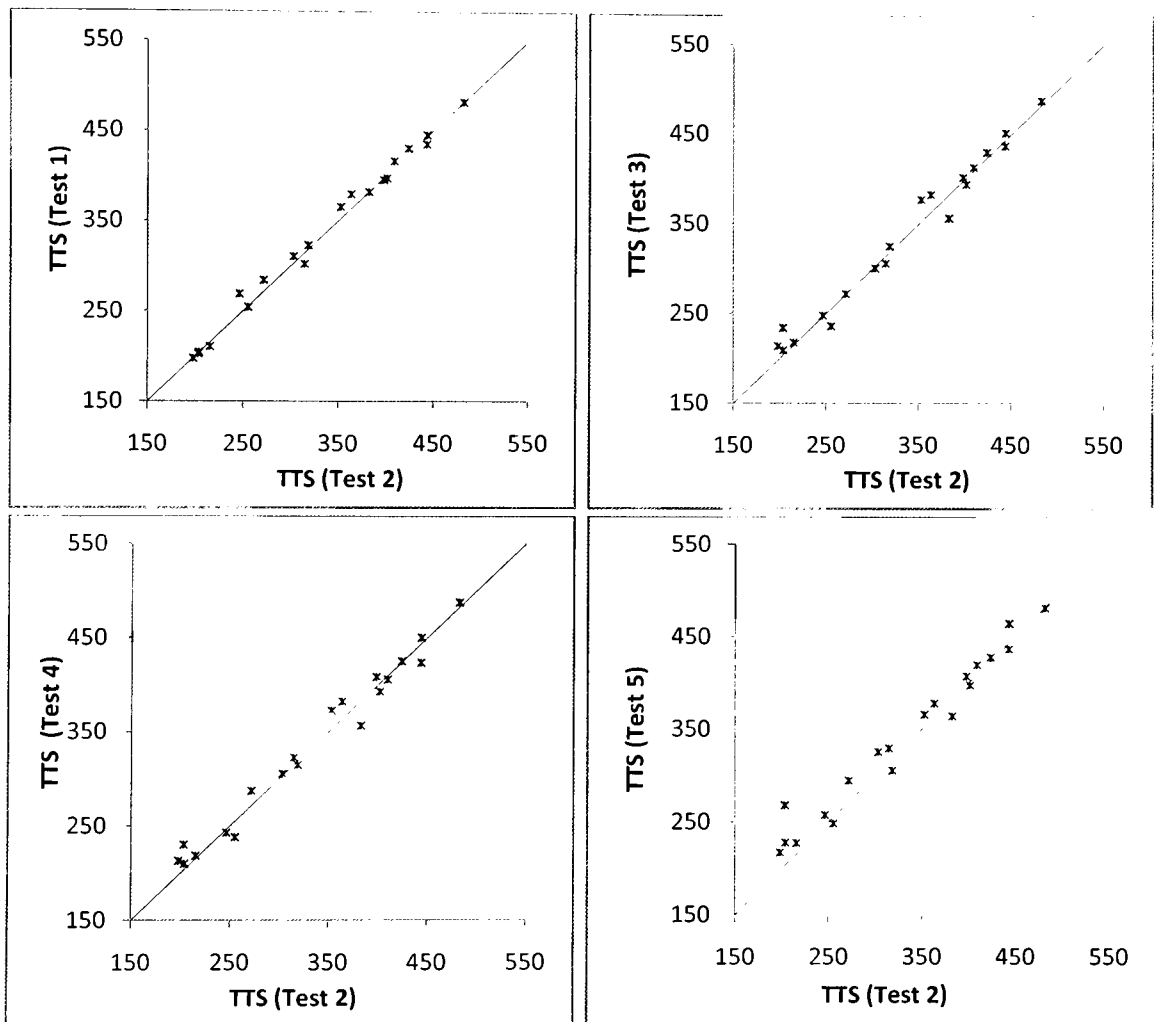

Figure 8-12 TTS obtained from the ANCONA algorithm with P and Sp1 values

Although the previous tests suggest an optimum value of P=10 minutes, additional tests have been carried out where the shutdown of RM was delayed until the queues created upstream of the stop line were discharged (i.e. using variable P value). Figure 8-13 compares the results of using variable P value with the case of having a fixed P value of 10 minutes as a base. In all these cases, Sp1 of 60 km/hr was used. The results shown in the figure do not reveal any considerable effect in using such a variable P compared with

the selected 10 minutes value. This may be due to the fact that using P equals to 10 minutes would be enough to discharge the queues before shutdown the RM. Therefore, the 10 minutes value would be recommended for use in practice.

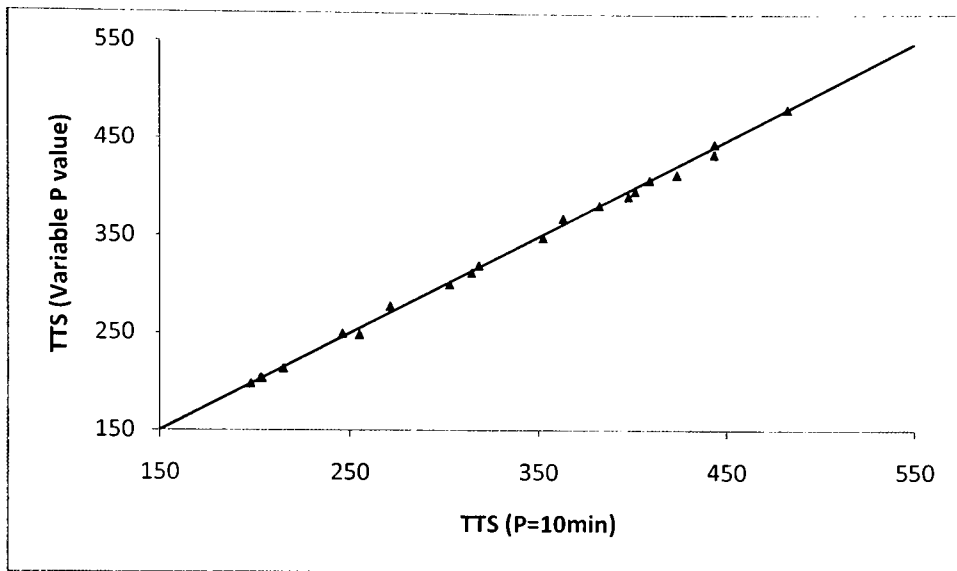

Figure 8-13 TTS obtained from P=10 minutes and variable P value

### 8.3. Effectiveness of RM controls

This section mainly focuses on comparing the time savings obtained from applying the above RM algorithms (i.e. ALINEA, D-C, RMPS and ANCONA algorithms) using their optimum parameters. This has been conducted for a wide range of flow rates as described in Table 8-1. The time spent saving has been calculated using Equation 8-1.

$$\text{Time saving (\%)} = \frac{100 [(\text{Time spent})_{\text{without control}} - (\text{Time spent})_{\text{with control}}]}{(\text{Time spent})_{\text{without control}}} \quad \text{Equation 8-1}$$

#### 8.3.1. Effect of RM on time spent for different algorithms

Figure 8-14, Figure 8-15 and Figure 8-16 show the effects of the different RM algorithms on TTSM, TTSR and TTS, respectively. Figure 8-14 suggests that all the selected RM algorithms could significantly reduce the travel time for motorway traffic. The figure also shows that the effectiveness of RM in reducing the TTSM is significantly reduced in cases when the total upstream flows (i.e. the sum of  $q_{in}$  and  $q_{ramp}$ ) are much higher than the downstream capacity. For example and for the ALINEA algorithm, the saving in TTSM for the case of  $q_{in}=5250$  veh/hr and  $q_{ramp}=900$  veh/hr was about 18% while the saving in TTSM was only about 5% for the case of higher  $q_{ramp}$  value of 1100 veh/hr (with similar  $q_{in}$  of 5250 veh/hr).

As expected, Figure 8-15 illustrates that the use of RM significantly increases the values for TTSR (this is shown in the figure by the negative values for the saving in TTSR). Such increase in the TTSR values exceeds 100% in most cases. Therefore, Figure 8-16 shows that RM controls could be effective in reducing the TTS values for only the cases where the sum of  $q_{\text{ramp}}$  and  $q_{\text{in}}$  are slightly higher than the motorway capacity (e.g. for  $q_{\text{ramp}}$  values of 700 to 800 veh/hr with  $q_{\text{in}}$  of 5500 veh/hr).

In cases where the sum of  $q_{\text{ramp}}$  and  $q_{\text{in}}$  are lower than the motorway capacity, RM controls are not really beneficial. In fact, further delays for traffic were resulted when using the ALINEA, D-C and RMPS algorithms at flow rates which are not causing congestion (e.g. for  $q_{\text{ramp}}$  of 800 veh/hr with  $q_{\text{in}}$  of 5250 veh/hr) or at flow rates which are causing "slight congestion" cases (e.g. for  $q_{\text{ramp}}$  of 600 veh/hr with  $q_{\text{in}}$  of 5500 veh/hr).

Note that, for the cases where the congestion has not occurred (e.g. see Figure 8-16 for  $q_{\text{ramp}}$  and  $q_{\text{in}}$  of 800 and 5250 veh/hr, respectively), the ANCONA algorithm has not been triggered (as discussed in section 3.6.3) resulting in no effect on the time spent. For the cases with "slight congestion", the ANCONA algorithm has been operated the RM system for a short periods and therefore caused lower negative effects on travel time compared with the other algorithms (e.g. see Figure 8-16 for  $q_{\text{ramp}}$  of 600 veh/hr with  $q_{\text{in}}$  of 5500 veh/hr).

Overall, the best results have been achieved by using the ANCONA algorithm. However, using a fixed value for  $q_2$  (i.e. 900 veh/hr) has limited the ability of the ANCONA algorithm in reducing the TTS values when the motorway upstream flow rate (i.e.  $q_{\text{in}}$ ) of 5000 veh/hr was used. Theoretically, a higher  $q_2$  value is needed in such a case provided that the sum of  $q_{\text{in}}$  and  $q_2$  is not lower than the motorway capacity. Therefore, some trials have been conducted in order to enhance the ANCONA algorithm further as will be discussed in section 8.4.

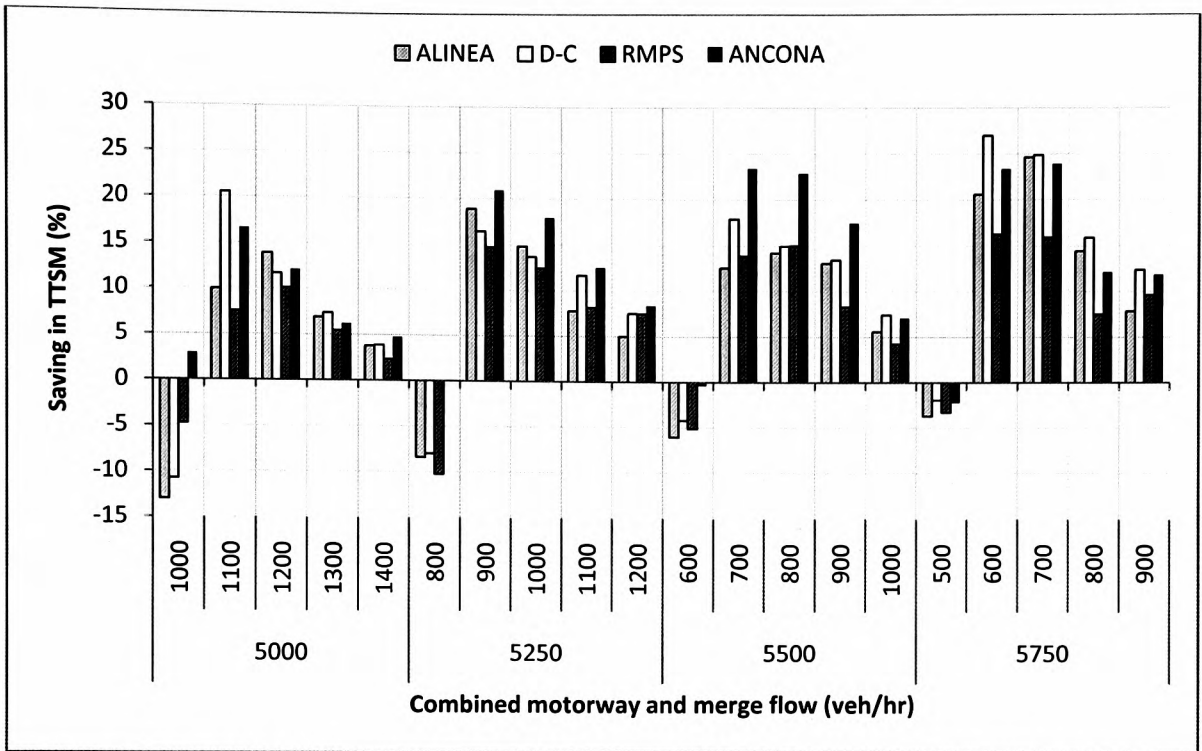

Figure 8-14 Saving in TTSM obtained from using different RM algorithms

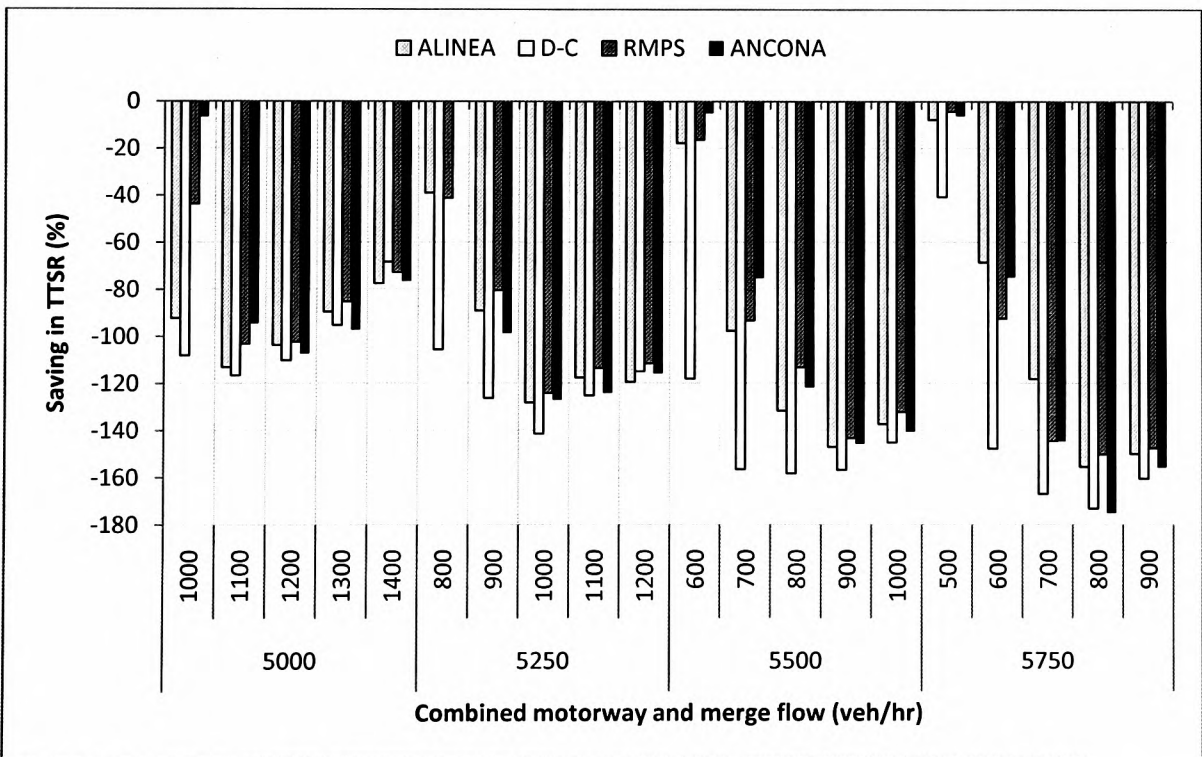

Figure 8-15 Saving in TTSR obtained from using different RM algorithms



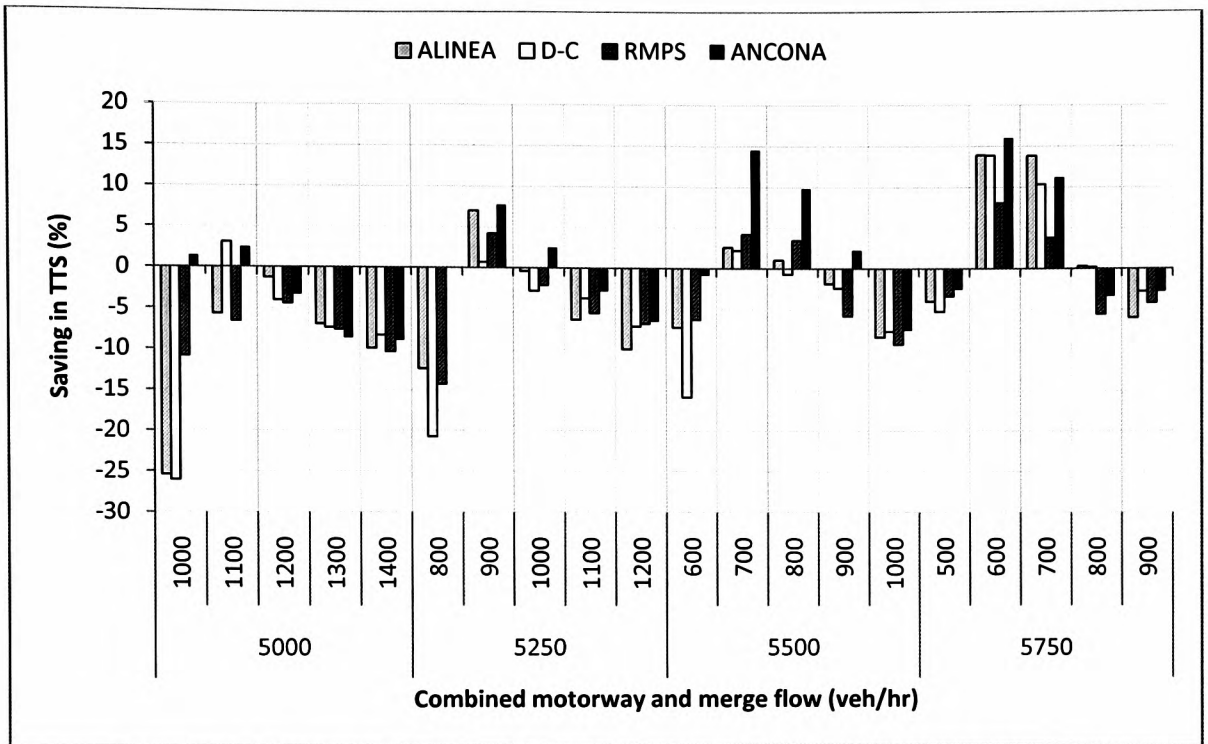

Figure 8-16 Saving in TTS obtained from using different RM algorithms

**8.3.2. Effect of RM on traffic delay (a typical example)**

In a similar way to the above figures that considered the effect of RM on time spent, the effect of RM on delays produced for motorway, merge and overall traffic are shown in Figure 8-17. It compares the scenarios of without RM and with the use of the ALINEA algorithm for the case of a motorway flow of 5750 veh/hr. The figure shows how the RM could reduce the delay for motorway traffic but with significant increases in the delay of the merging traffic. The slope of the curve for merge traffic delay has significantly been reduced for flow rates higher than 800 veh/hr because of the effect of the limited storage length (i.e. ramp length) as well as the effect of QOS which prevents queues from exceeding this storage length. The benefits obtained from the RM in reducing the overall delay are limited for merge traffic up to 800 veh/hr.

The results presented in the Figure 8-17 confirm the similarity in the use of time spent and in delay measurements in evaluating the effectiveness of traffic management controls (e.g. see Figure 8-14 to Figure 8-16 to for the case of  $q_m$  of 5750 veh/hr).

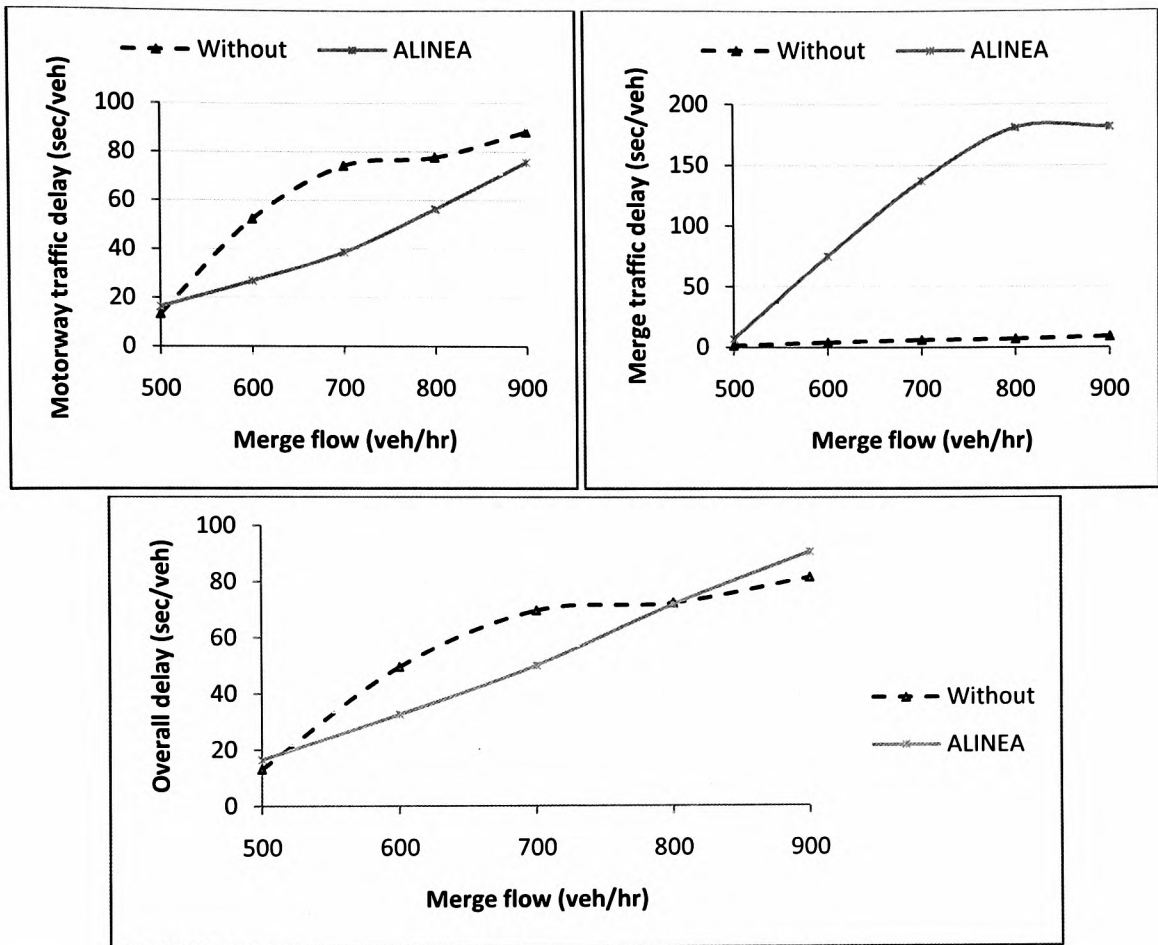

Figure 8-17 Effect of RM on traffic delay

## 8.4. Improvements to the ANCONA algorithm

### 8.4.1. Introduction

The above section highlighted the ANCONA algorithm as the optimum one since it provides lower time spent values (i.e. higher time spent saving) when compared with the other algorithms in the majority of the tested case. However, there are still some limitations that could be considered in order to get even better results. These limitations can be summarised as follows:

- The shutdown criterion does not consider the existence of queues on the ramp section (see Kerner, 2007a, b, c and d).
- There is no clear criterion for selecting the metering rate value ( $q_2$ )
- The ANCONA algorithm does not consider the effect of the operating speed values on selecting the value of  $q_2$  when the speed of upstream section is significantly increased above  $Sp_1$ .

## 8.4.2. New ANCONA derivative algorithms

### 8.4.2.1. (ANCONA-M1): Enhancing the shutting down criteria

This is identical to the ANCONA algorithm in applying two metering rates of  $q_1$  and  $q_2$  for speeds on the upstream detectors which are lower and higher than  $Sp_1$ , respectively. A maximum metering rate ( $q_{max}$ ) is introduced in a case where the speed on the upstream detectors is increased to be higher than say, 80 km/hr. This third (maximum) metering rate is applied for two reasons. The first is to discharge the queues created on the ramp section before the shutdown of the RM (by allowing maximum possible green time) and the second is to release higher number of vehicles from the signals if the speed is significantly increased for a level higher than  $Sp_1$ . Figure 8-18 shows the flowchart of the ANCONA-M1 algorithm after operating the RM system.

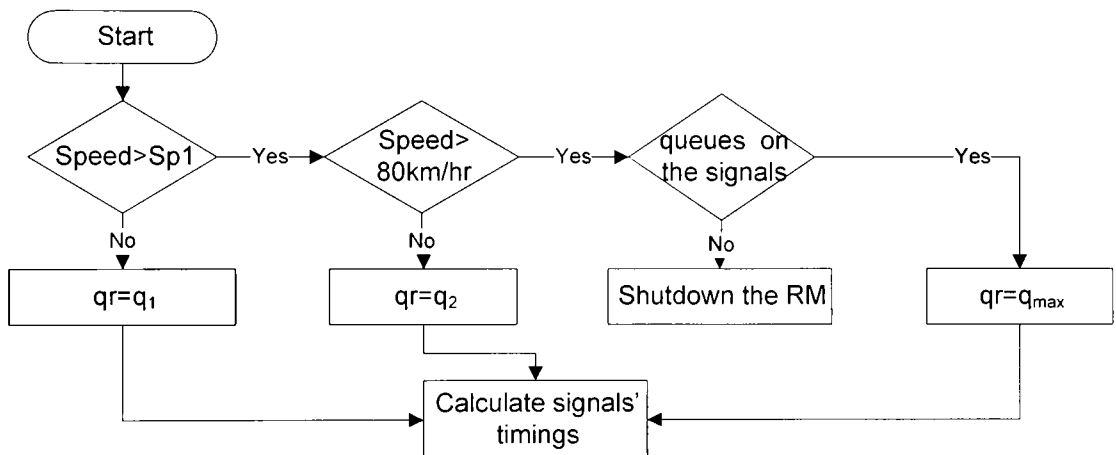

Figure 8-18 The ANCONA-M1 algorithm

### 8.4.2.2. (ANCONA-M2): Based on different speed levels

This algorithm considers the effect of increasing the speed (for speeds higher than  $Sp_1$ ) on the metering rate by operating the RM based on different speed levels. The operation procedure for this algorithm is as follows (see Figure 8-19):

- Triggering the signals on by using a metering rate of  $q_1$  if the motorway speed is lower than  $Sp_1$ .
- Using a higher metering rate ( $q_2$ ) when the speed becomes higher than  $Sp_1$ .
- Increasing the metering rate to a new assumed value of  $q_3$  when the speed is higher than a suggested value  $Sp_2$  (where  $Sp_2$  is greater than  $Sp_1$ ).

- If the speed is increased above a value of 80 km/hr, the RM will either shut down or operate using a maximum metering rate similar to that used in the ANCONA-M1 algorithm.

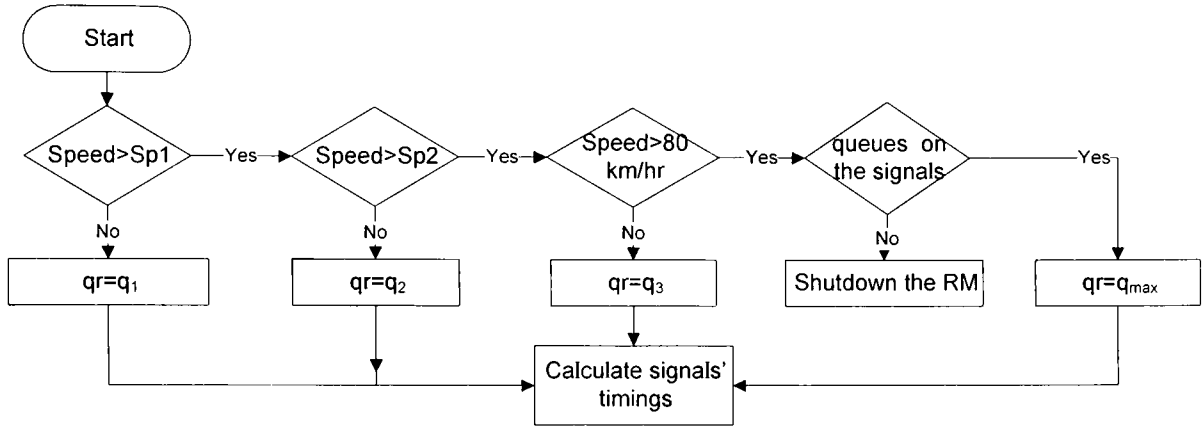

Figure 8-19 The ANCONA-M2 algorithm

**8.4.2.3. (ANCONA-M3): Considering the ramp flow rates**

This algorithm considers the effects of ramp flow rates on the metering rates. This is to ensure that the RM is able to discharge all the merge traffic after recovering normal traffic conditions. The algorithm operates as follows (see Figure 8-20):

- Triggering the signals on by using a metering rate of  $q_1$  if the motorway speed is lower than  $Sp_1$ .
- Using a higher metering rate obtained from Equation 8-2 when the upstream speed becomes higher than  $Sp_1$ . This metering rate is higher than the ramp flow rate during the previous time interval.
- The shutdown criterion is similar to that in the ANCONA-M1 algorithm above.

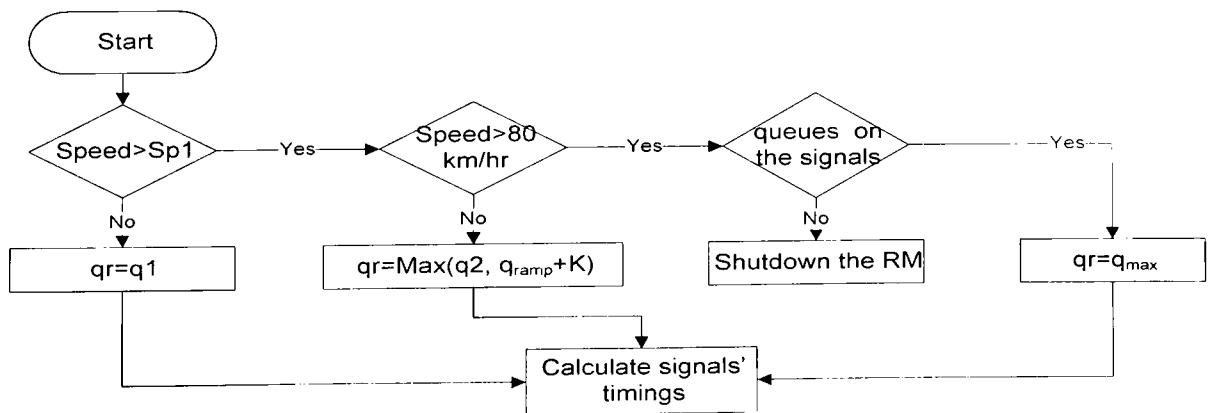

Figure 8-20 The ANCONA-M3 algorithm

$$q_r = \max(q_2, q_{\text{ramp}} + K) \quad \text{Equation 8-2}$$

where  $K$  (in veh/hr) is the calibration parameter.

#### 8.4.2.4. Hybrid ALINEA-ANCONA (AL-AN) algorithm

The AL-AN algorithm combines both ALINEA and ANCONA logic (see Figure 8-21). This hybrid algorithm operates the minimum metering rate of  $q_1$  similar to that used by the ANCONA algorithm (i.e. when the upstream speed drops below the  $Sp_1$  value). If the speed is increased above the  $Sp_1$  value (i.e. the normal traffic condition is recovered), the AL-AN algorithm estimates the metering rate based on the ALINEA algorithm using Equation 8-3 (i.e. from using the occupancy measurements downstream of the merge section). This is to overcome the existing limitations of the ANCONA algorithm as it is not sensitive to the variation of the traffic parameters (such as speed and occupancy) during normal traffic conditions. The shutdown criterion is similar to that described in the ANCONA-M1 algorithm.

$$q_r = \max(q_2, \text{metering rate from ALINEA}) \quad \text{Equation 8-3}$$

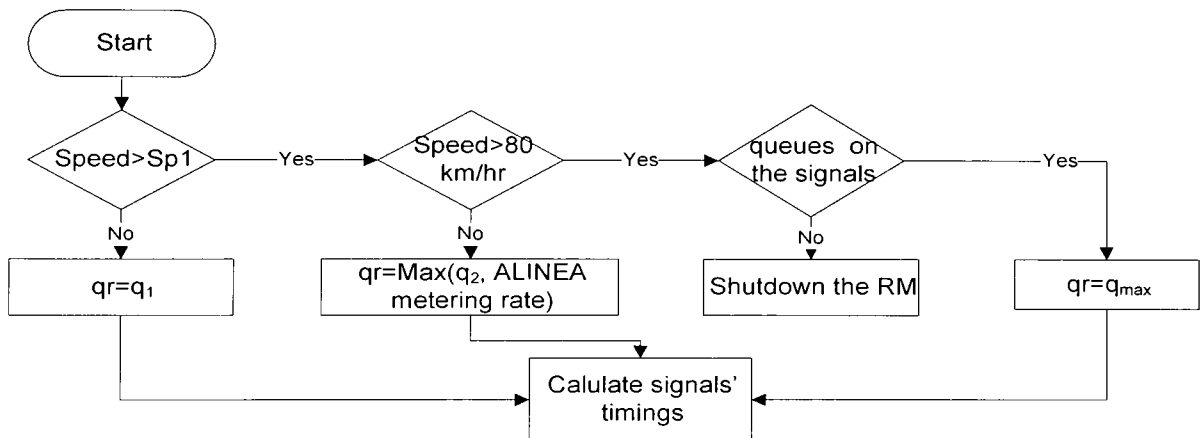

Figure 8-21 The hybrid AL-AN algorithm

#### 8.4.3. Selected parameters

The following values were selected in testing the ANCONA derivatives algorithms:

- For the ANCONA-M1 algorithm,  $Sp_1$  value of 60 km/hr is used which is similar to that obtained from the ANCONA algorithm (see section 8.2.3.3). The maximum metering rate ( $q_{\text{max}}$ ) of 1600 veh/hr, similar to that applied by Smaragdis and Papageorgiou (2003), is used.
- For the ANCONA-M2 algorithm, different values have been tested for  $Sp_1$  with fixed values of 70 km/hr and 1200 veh/hr for  $Sp_2$  and  $q_3$  respectively. Values of 400

and 900 veh/hr, similar to those used in the original ANCONA algorithm, are respectively used for  $q_1$  and  $q_2$ . The maximum metering rate ( $q_{\max}$ ) of 1600 veh/hr is used similar to that in the ANCONA-M1 algorithm. The optimum Sp1 value is obtained from a sensitivity analysis showing the effect on time spent for different Sp1 values using the flow rates given in Figure 8-2. Figure 8-22 shows the results of the sensitivity tests and suggest that the lowest TTS, TTSM and TTSR values were obtained when Sp1 is 60 km/hr. This is similar to that obtained from the optimisation of the original ANCONA algorithm (see section 8.2.3.3). The validity of this selection has been examined by testing the effect of using 60, 65 and 70 km/hr for Sp1 values with the flow rates given in Table 8-1. Using a base value of 60 km/hr, the results as shown in Figure 8-23 suggest that both 60 and 65 km/hr values gave almost similar TTS which are lower than those obtained from 70 km/hr. For the purpose of this work, a value of 60 km/hr is adopted.

- For the ANCONA-M3 algorithm, Sp1,  $q_1$ ,  $q_2$  and  $q_{\max}$  are used similarly to those values used in the ANCONA-M1 and ANCONA-M2 algorithms. Values of 0, 100, and 200 veh/hr have been tested for K parameter (see Equation 8-2) with the flow rates given in Table 8-1. The result of the TTS, as presented in Figure 8-24 with a base value of  $K=0$ , suggests that both 0 and 100 veh/hr values are slightly better than the 200 veh/hr value. The results obtained from  $K=0$  veh/hr are used in the next section.
- For the hybrid AL-AN algorithm, the optimum parameters obtained from both the ALINEA and ANCONA algorithms (see section 8.2.3) are used.

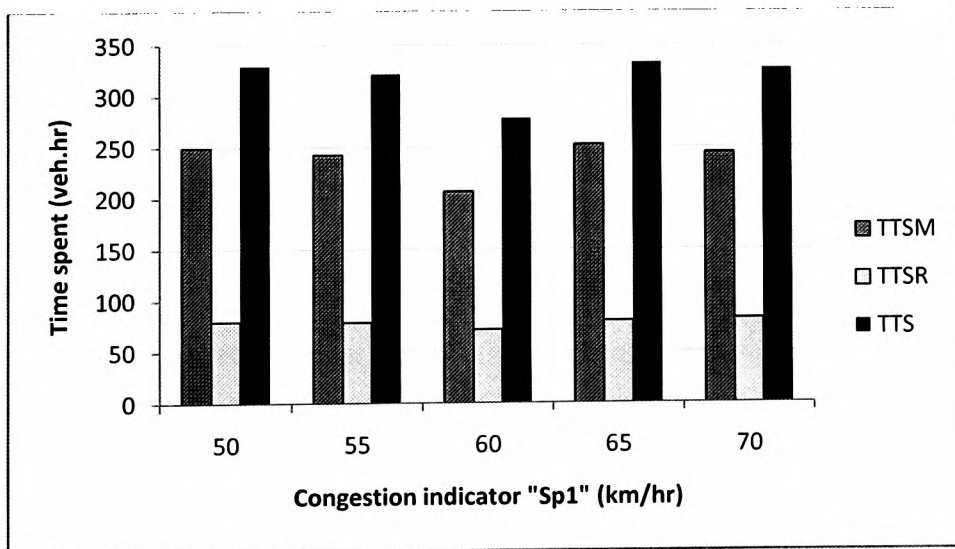

Figure 8-22 Effect of Sp1 on travel spent using the ANCONA-M2 algorithm

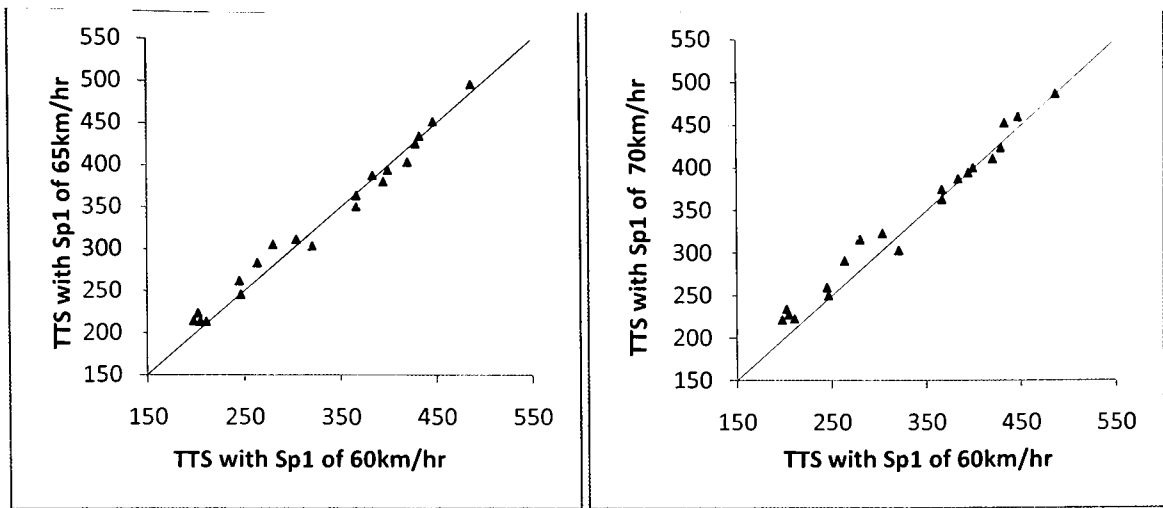

Figure 8-23 TTS obtained from the ANCONA-M2 algorithm with flow rates given in Table 8-1

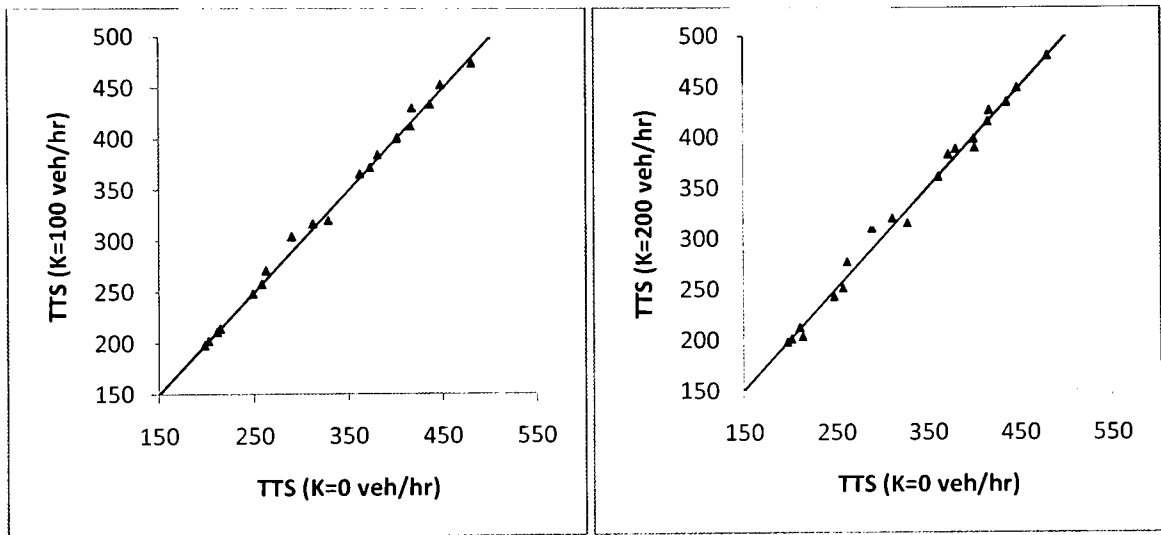

Figure 8-24 TTS obtained from the ANCONA-M3 algorithm with flow rates given in Table 8-1

**8.4.4. Effectiveness of the ANCONA derivative algorithms**

Figure 8-25 presents the saving in TTSM, TTSR and TTS obtained from applying the original ANCONA algorithm and the newly developed ANCONA derivatives algorithms (i.e. ANCONA-M1, ANCONA-M2, ANCONA-M3 and the hybrid AL-AN).

In general, the figure shows that all of the modified algorithms could improve the implementation of the original ANCONA by increasing the savings in time spent. Such improvements are limited to specific ranges of flow rates close to those of the motorway capacity (e.g.  $q_{in}$  and  $q_{ramp}$  of 5000 and 1100 veh/hr, respectively) At such flow rates, the proposed algorithms provide 10-18% improvement in TTS.



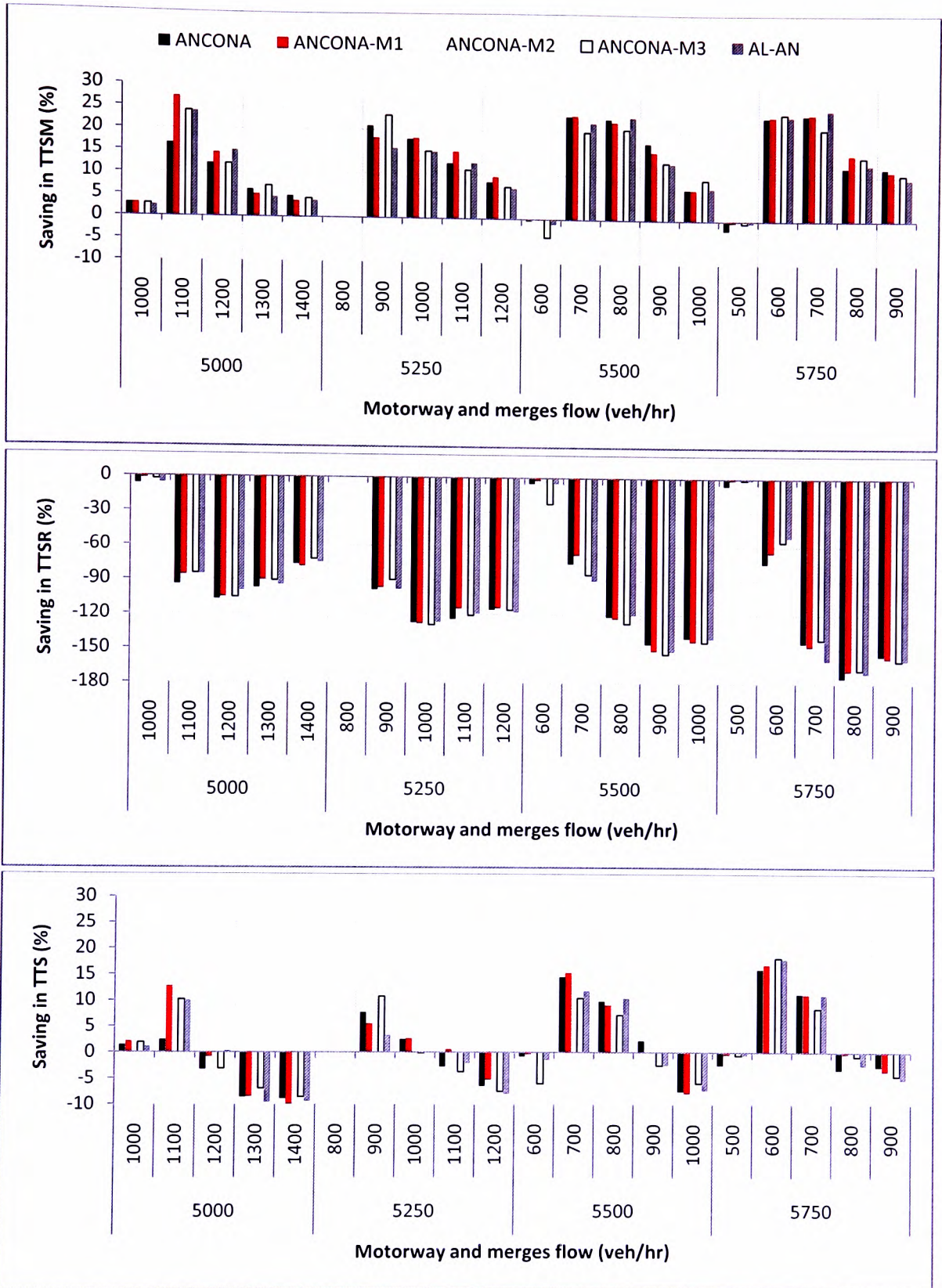

Figure 8-25 Saving in time spent obtained from the original ANCONA and its developed derivations

The lowest TTSM and TTS values (i.e. highest time saving) have been achieved by using the ANCONA-M1, ANCONA-M2 and ANCONA-M3 algorithms. In fact, no significant



difference can be noticed among these three algorithms and that suggests that the ANCONA-M1 algorithm is more practical since it has a lower number of parameters to calibrate and if necessary use in practice.

For Flow rates which are much higher than the capacity (e.g. for  $q_{in}$  of 5000 veh/hr with  $q_{ramp}$  of 1300 veh/hr), no improvements have been achieved compared with the ANCONA algorithm because the RM system, in general, cannot deal with such higher flow rates (as discussed in section 8.3). In addition, no variations in the TTS results were found among all of the RM algorithms presented in Figure 8-25 at such high flow rates.

Using the hybrid AL-AN algorithm, in general, did not help in reducing the time spent compared with the original ANCONA algorithm. However, there are some benefits in reducing time spent as illustrated in the case of having a merge flow of 1100 veh/hr with a motorway flow of 5000 veh/hr.

As a summary, it could be concluded that the developed ANCONA modified algorithms are more efficient than the ANCONA algorithm in dealing with the variation of motorway flow rates. This is related to the difficulty of selecting the  $q_2$  value in the original ANCONA algorithm. It is worth mentioning here that the results of the hybrid AL-AN algorithm are also better than the TTS results obtained from the ALINEA algorithm (see Figure 8-16 for the ALINEA results).

## **8.5. Further tests using a selection of RM algorithms**

The above sections suggested that using the ANCONA-M1, ANCONA-M2 and ANCONA-M3 algorithms could provide better results from those obtained from the original ANCONA algorithm in term of reducing TTSM and TTS. In addition, the results in section 8.3 suggested that ALINEA, D-C and RMPS algorithms are generally similar. Therefore, and in order to minimise the number of algorithms used in further tests, it was decided to use the ALINEA and one of the modified ANCONA algorithm (such as ANCONA-M2 algorithms).

### **8.5.1. Effect of ramp length**

#### **8.5.1.1. Effect of ramp length using the ALINEA algorithm**

The effect of ramp length, using the flow rates shown in Figure 8-2, on the upstream throughput and speed are shown in Figure 8-26. The figure indicates that, as the ramp length increases, speed and throughput for the main motorway increases up to a ramp

length of about 500-600m. Similarly, Figure 8-27 shows the effect of ramp length on the time spent for motorway traffic (TTSM), merge traffic (TTSR) and the overall (total) traffic (TTS). The figure shows that the longer a ramp length is the lower the TTSM values and the higher the TTSR values. The TTS values have slightly reduced with the increase in ramp length.

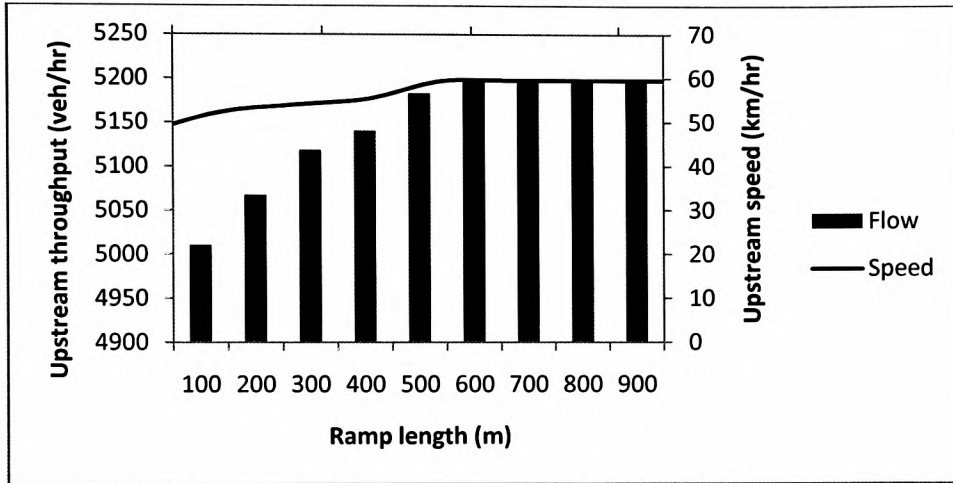

Figure 8-26 Effect of ramp length on motorway throughput and speed using the ALINEA algorithm

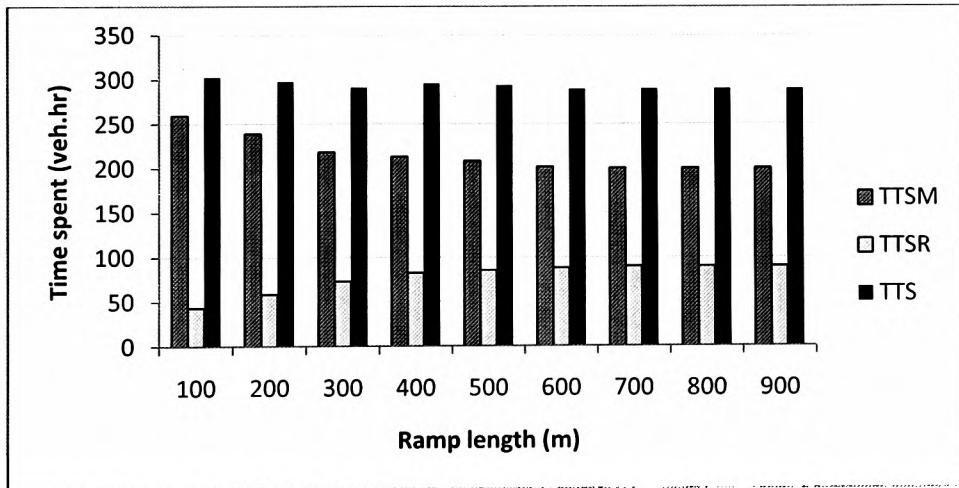

Figure 8-27 Effect of ramp length on the time spent using the ALINEA algorithm

The reason behind the limited effect of the ramp length when it is longer than about 500-600m is that the whole storage length is not used because the desired occupancy ( $O_{des}$ ) is selected on traffic conditions based on a ramp length of up to 300m. However, if there is a relatively higher ramp length, the selected  $O_{des}$  could be reduced to less than 23%.

Figure 8-28 compares the queue length obtained from simulation for two occupancy values, 21% and 23%. The figure reveals that for the lower occupancy value (i.e. 21%), longer ramp queue lengths will be obtained. In practice, lower  $O_{des}$  rates could be applied

when there is no limit to the storage ramp area (e.g. motorway to motorway merge sections). However, attention should be given to the effect of such a reduction in  $O_{des}$  values on the TTS values.

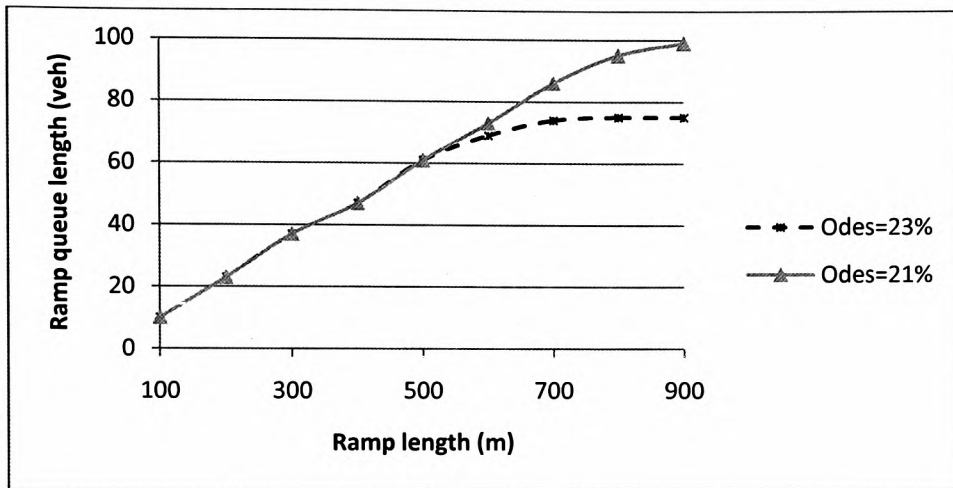

Figure 8-28 Effect of selected  $O_{des}$  on queue length using the ALINEA algorithm

Figure 8-29 shows the effect of having an infinite length of storage area (e.g. motorway to motorway merge sections) or where the effect of such queues is not considered. The figure shows that lower  $O_{des}$  values could successfully keep the motorway speed at higher rates. This could explain why other studies (e.g. Sarintorn, 2007) suggested that  $O_{des}$  of 17% would be suitable in such cases if only the benefits to the motorway traffic were considered.

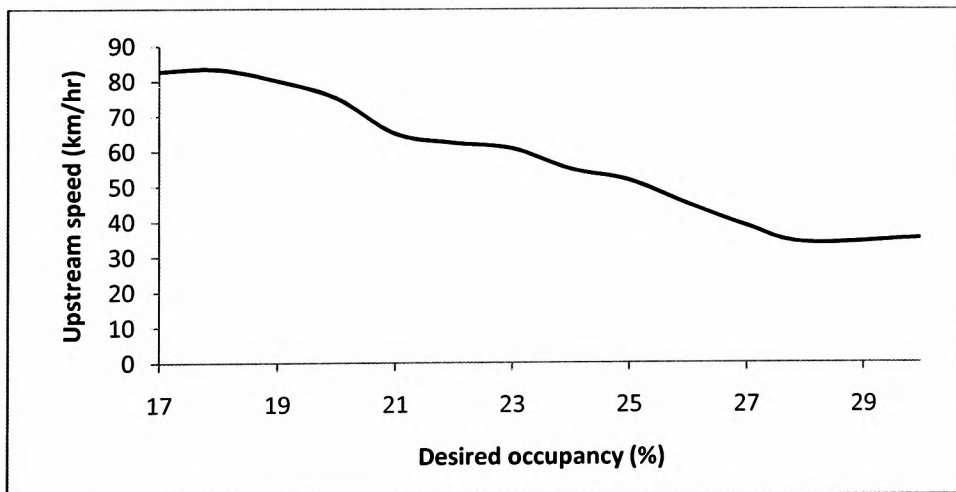

Figure 8-29 Effect of selected  $O_{des}$  on upstream speed with no queue control

### 8.5.1.2. Effect of ramp length using the ANCONA-M2 algorithm

Figure 8-30 shows the effect of applying the ANCONA-M2 algorithm using different ramp lengths on speed and on throughput parameters upstream of the merge section ramp. The figure suggests that the ANCONA-M2 algorithm could keep the upstream traffic speed and

flow at higher rates than those achieved from using the ALINEA algorithm. Such improvements have been achieved from the ANCONA-M2 algorithm even when the used storage length is lower than that used by applying the ALINEA algorithm as shown in Figure 8-31.

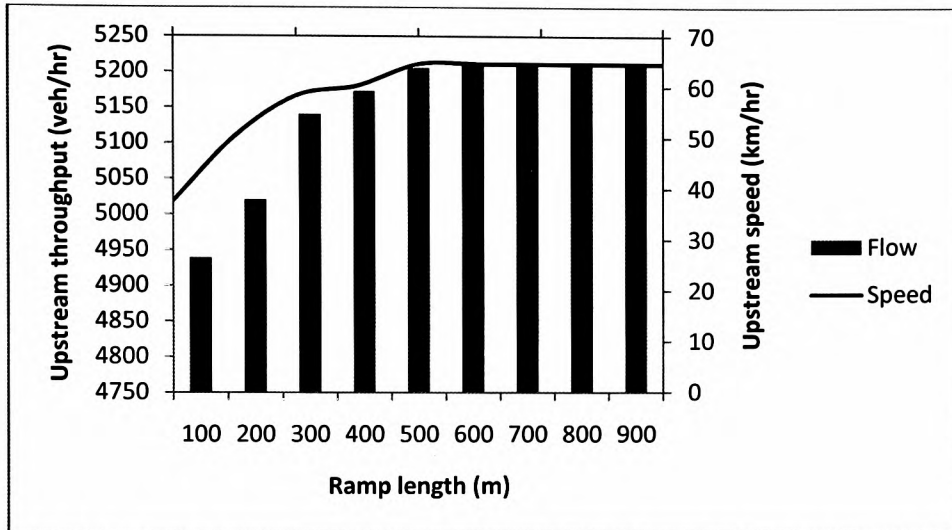

Figure 8-30 Effect of ramp length on motorway throughput and on motorway upstream speed using the ANCONA-M2 algorithm

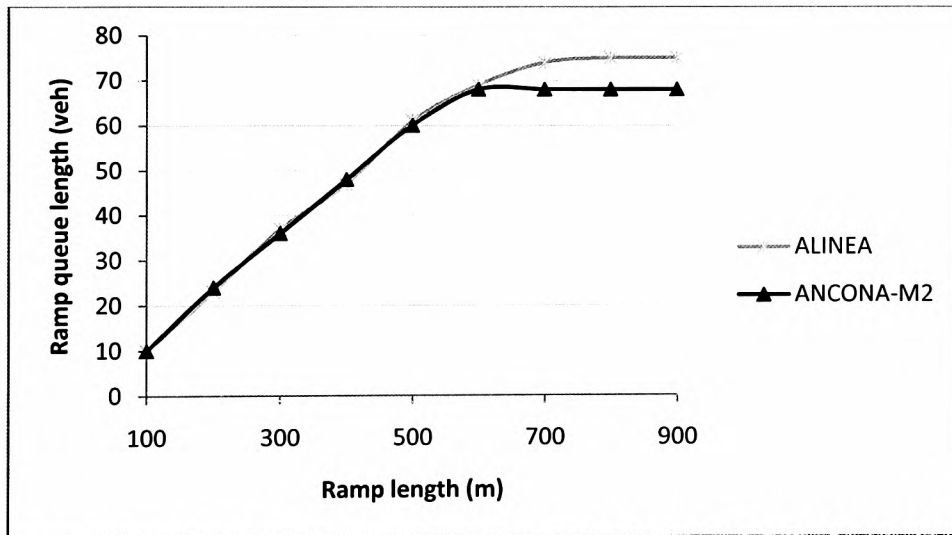

Figure 8-31 Comparison between queue lengths obtained by using the ALINEA and ANCONA-M2 algorithms

**8.5.2. Effectiveness of RM under different peak periods**

Due to normal traffic variations (such as daily, weekly and monthly variations), each section may receive different peak periods of flow rates. Some peak periods do not exceed 10 minutes while others may continue for many hours. In the above section, the effectiveness of RM with 60 minute peak periods showed that the RM could not reduce the TTS in most cases especially when the sum of the upstream motorway traffic and the

merge traffic is much higher than the downstream capacity. This section examines the effect of having different peak periods of 15, 30, 60 and 90 minutes with the whole range of flow rates described in Table 8-1. A typical length of 240m has been used for the ramp length (i.e. 200m clear storage length) to cover most cases of existing storage lengths in the UK for RM systems.

The results for the 90 minutes' peak period as shown in Table 8-4 suggest that RM could reduce the TTSM for most of the selected flow rates but could not enhance the TTS especially in case of the ALINEA algorithm (see the embolded values in the table for the cases where RM could produce saving in TTS). In general there are more instances where the ANCONA-M2 algorithm has reduced in lower TTS when compared with the ALINEA algorithm.

Table 8-4 Saving in TTSM, TTSR and TTS with a 90 minutes' peak period

$q_{in}$ (veh/hr)	$q_{ramp}$ (veh/hr)	ALINEA			ANCONA-M2		
		TTSM%	TTSR%	TTS%	TTSM%	TTSR%	TTS%
5000	1000	-29.6	-104.5	-41.4	10.6	-24.8	<b>5.0</b>
	1100	1.5	-102.4	-11.2	13.0	-89.7	<b>0.4</b>
	1200	7.6	-95.2	-5.4	6.5	-97.1	-6.7
	1300	4.4	-59.5	-6.0	4.0	-68.1	-7.7
	1400	1.6	-59.8	-10.4	1.6	-50.8	-8.6
5250	800	-12.3	-55.1	-18.2	2.3	-6.0	<b>1.1</b>
	900	6.8	-102.8	-4.9	11.9	-103.3	-0.4
	1000	3.1	-116.5	-9.4	9.8	-114.8	-3.2
	1100	2.7	-106.5	-9.6	3.8	-109.8	-9.0
	1200	2.6	-99.8	-10.1	3.0	-98.4	-9.5
5500	600	-6.2	-17.2	-7.4	-0.4	-3.1	-0.7
	700	6.3	-121.9	-4.8	21.7	-84.5	<b>12.5</b>
	800	5.2	-140.3	-7.3	11.9	-135.0	-0.6
	900	4.5	-127.5	-7.7	7.9	-127.9	-4.7
	1000	4.5	-116.6	-7.6	4.9	-119.2	-7.5
5750	500	-4.6	-9.7	-5.1	-0.1	-1.4	-0.2
	600	23.9	-85.7	<b>15.9</b>	22.5	-86.1	<b>14.6</b>
	700	14.6	-143.5	<b>3.0</b>	13.0	-154.1	<b>0.7</b>
	800	10.0	-134.8	-1.6	10.5	-142.4	-1.8
	900	4.7	-129.3	-7.4	4.9	-135.8	-7.8

For the 60 minutes' peak period, as shown in Table 8-5, some enhancements have been achieved for both the TTSM and TTS. Again, the ANCONA-M2 algorithm has produced savings in the TTS values for more instances than the ALINEA algorithm (see the embolded values in the table).

For the 15 and 30 minutes' peak periods, the initial simulation results indicate that the benefit of RM could be extended to wider ranges of flow rates and therefore the merging flow rates have been extended accordingly for these two periods. Table 8-6 shows the results for the case of 30 minutes' periods and suggests that the range of flow rates when RM could reduce the TTS has significantly increased compared with those ranges obtained from cases with 60 and 90 minutes' peak periods. Similarly, Table 8-7 presents the results for the case of the 15 minutes' peak period and reveals the ability of RM controls in dealing with such low peak periods by reducing TTSM and TTS for the most of the tested flow rates. This could be due to the fact that RM under limited storage length could only delay the occurrence of traffic congestion for a short period. This may explain the lack of agreement in the effectiveness of RM reported in previous research (see section 3.6.6).

Table 8-5 Saving in TTSM, TTSR and TTS with a 60 minutes' peak period

$Q_{in}$ (veh/hr)	$Q_{ramp}$ (veh/hr)	ALINEA			ANCONA-M2		
		TTSM%	TTSR%	TTS%	TTSM%	TTSR%	TTS%
5000	1000	-20.0	-77.2	-29.0	2.7	-2.8	<b>1.8</b>
	1100	5.1	-90.1	-7.0	20.6	-69.7	<b>9.1</b>
	1200	10.8	-80.1	-0.9	10.6	-81.3	-1.2
	1300	5.6	-66.4	-4.7	4.8	-70.6	-6.0
	1400	1.5	-58.6	-8.7	1.5	-52.4	-7.6
5250	800	-9.1	-38.6	-13.0	0.0	0.0	0.0
	900	10.2	-74.1	<b>0.9</b>	18.2	-72.5	<b>8.2</b>
	1000	4.7	-103.8	-6.8	13.8	-99.3	<b>1.8</b>
	1100	5.4	-91.5	-5.5	7.2	-94.5	-4.2
	1200	3.1	-87.0	-7.7	4.4	-85.9	-6.4
5500	600	-6.0	-17.8	-7.2	-1.0	-4.3	-1.3
	700	10.5	-88.4	<b>1.6</b>	20.3	-62.4	<b>12.9</b>
	800	12.6	-108.7	<b>1.7</b>	18.2	-99.9	<b>7.6</b>
	900	6.1	-109.2	-4.7	9.1	-116.7	-2.6
	1000	3.6	-105.4	-7.2	4.2	-110.5	-7.1
5750	500	-3.7	-7.8	-4.0	-0.4	-1.4	-0.5
	600	20.3	-58.2	<b>14.4</b>	23.1	-50.4	<b>17.6</b>
	700	20.8	-112.1	<b>10.8</b>	18.5	-127.0	<b>7.5</b>
	800	10.8	-114.5	<b>0.4</b>	11.2	-127.3	-0.2
	900	8.7	-113.3	-2.0	8.6	-120.9	-2.8

From the above, it can be concluded that RM may not be beneficial for long durations of peak periods (e.g. 90 minutes or more). For shorter peak periods, Figure 8-32 summarises useful ranges of flow rates for peak periods of 60 and 30 minutes. In the case of having a

very short peak period such as 15 minutes, it is found that RM is able to reduce the TTS for the whole of the tested flow rates as presented in Table 8-7.

Table 8-6 Saving in TTSM, TTSR and TTS with a 30 minutes' peak period

q <sub>in</sub> (veh/hr)	q <sub>ramp</sub> (veh/hr)	ALINEA			ANCONA-M2		
		TTSM%	TTSR%	TTS%	TTSM%	TTSR%	TTS%
5000	1000	-3.9	-29.9	-7.3	0.0	0.0	0.0
	1100	10.2	-53.5	<b>2.0</b>	16.0	-28.9	<b>10.2</b>
	1200	15.2	-55.8	<b>6.2</b>	18.0	-56.6	<b>8.6</b>
	1300	11.4	-58.2	<b>2.4</b>	11.8	-58.0	<b>2.7</b>
	1400	7.3	-51.1	-1.0	9.1	-51.3	<b>0.5</b>
	1500	4.7	-62.5	-4.8	5.2	-62.3	-4.4
5250	800	-2.4	-12.8	-3.6	0.0	0.0	0.0
	900	8.4	-35.1	<b>3.4</b>	11.1	-29.9	<b>6.5</b>
	1000	6.3	-68.4	-2.1	14.3	-63.2	<b>5.6</b>
	1100	9.7	-64.2	<b>1.3</b>	12.3	-67.1	<b>3.3</b>
	1200	8.3	-75.7	-1.2	10.2	-72.9	<b>0.8</b>
	1300	5.7	-72.5	-3.7	8.9	-68.1	-0.3
	1400	4.8	-66.2	-4.3	5.5	-65.3	-3.5
	1500	3.6	-50.5	-4.2	6.9	-52.0	-1.6
5500	600	-2.5	-13.0	-3.5	0.0	-3.0	-0.3
	700	4.4	-44.0	-0.3	9.8	-31.1	<b>5.9</b>
	800	10.8	-58.0	<b>4.2</b>	12.2	-51.1	<b>6.1</b>
	900	12.4	-66.7	<b>4.7</b>	15.8	-79.5	<b>6.5</b>
	1000	12.0	-73.6	<b>3.6</b>	11.8	-81.7	<b>2.6</b>
	1100	9.7	-70.1	<b>1.3</b>	12.3	-73.9	<b>3.3</b>
	1200	6.8	-78.0	-2.3	7.9	-76.3	-1.1
	1300	1.8	-70.4	-6.6	2.6	-79.9	-7.0
5750	500	-0.4	-2.5	-0.6	-0.3	-1.5	-0.4
	600	10.1	-23.1	<b>7.3</b>	12.7	-19.4	<b>10.0</b>
	700	17.6	-50.1	<b>11.9</b>	18.1	-66.1	<b>11.1</b>
	800	17.0	-63.9	<b>10.0</b>	19.2	-73.4	<b>11.2</b>
	900	12.9	-76.5	<b>4.8</b>	13.5	-82.0	<b>4.8</b>
	1000	10.9	-79.4	<b>2.3</b>	12.7	-81.5	<b>3.7</b>
	1100	6.4	-78.0	-2.1	7.7	-81.9	-1.3
	1200	2.9	-78.4	-5.7	4.7	-78.7	-4.0

Table 8-7 Saving in TTSM, TTSR and TTS with a 15 minutes' peak period

Q <sub>in</sub> (veh/hr)	Q <sub>ramp</sub> (veh/hr)	ALINEA			ANCONA-M2		
		TTSM%	TTSR%	TTS%	TTSM%	TTSR%	TTS%
5000	1000	-0.3	-4.8	-0.8	0.0	0.0	0.0
	1100	2.2	-24.1	-0.9	3.6	-12.1	<b>1.7</b>
	1200	7.3	-27.5	<b>3.2</b>	6.9	-28.7	<b>2.7</b>
	1300	7.2	-29.5	<b>2.7</b>	7.6	-28.1	<b>3.2</b>
	1400	8.8	-35.4	<b>3.3</b>	8.4	-41.1	<b>2.3</b>
	1500	9.3	-33.6	<b>3.7</b>	8.5	-36.5	<b>2.7</b>
	1600	8.0	-32.2	<b>2.5</b>	7.6	-35.1	<b>1.7</b>
	1700	7.7	-25.7	<b>2.9</b>	11.0	-24.2	<b>5.9</b>
	1800	7.7	-25.7	<b>2.5</b>	7.2	-34.4	<b>0.8</b>
	1900	4.8	-27.9	-0.5	7.3	-26.6	<b>1.8</b>
5250	800	-0.6	-3.8	-0.9	0.0	0.0	0.0
	900	2.3	-10.8	<b>0.9</b>	2.4	-10.7	<b>1.0</b>
	1000	3.4	-31.1	-0.4	5.5	-24.5	<b>2.3</b>
	1100	3.9	-28.7	<b>0.2</b>	5.8	-29.9	<b>1.8</b>
	1200	8.6	-41.2	<b>3.0</b>	8.9	-39.8	<b>3.4</b>
	1300	9.3	-41.2	<b>3.4</b>	9.4	-39.2	<b>3.7</b>
	1400	8.8	-40.0	<b>3.0</b>	10.3	-39.5	<b>4.3</b>
	1500	9.8	-33.0	<b>4.3</b>	11.5	-32.6	<b>5.9</b>
	1600	9.1	-34.7	<b>3.2</b>	9.0	-34.6	<b>3.2</b>
1700	7.0	-34.3	<b>1.2</b>	9.5	-30.4	<b>3.9</b>	
5500	600	-0.5	-4.9	-0.9	0.5	-2.4	<b>0.2</b>
	700	1.2	-14.9	-0.4	2.4	-11.3	<b>1.0</b>
	800	3.3	-21.4	<b>0.9</b>	4.7	-18.8	<b>2.4</b>
	900	5.1	-25.1	<b>2.1</b>	6.6	-34.2	<b>2.5</b>
	1000	7.9	-30.2	<b>4.0</b>	8.6	-42.9	<b>3.4</b>
	1100	9.3	-36.0	<b>4.5</b>	11.1	-39.2	<b>5.8</b>
	1200	10.0	-49.4	<b>3.8</b>	10.6	-50.6	<b>4.2</b>
	1300	8.7	-43.7	<b>2.9</b>	11.9	-46.9	<b>5.4</b>
	1400	9.5	-42.9	<b>3.6</b>	8.6	-46.2	<b>2.4</b>
	1500	9.1	-31.8	<b>4.2</b>	11.3	-39.1	<b>5.2</b>
5750	500	0.4	-1.6	<b>0.3</b>	-0.1	-1.5	-0.2
	600	2.6	-7.9	<b>1.7</b>	3.3	-9.4	<b>2.2</b>
	700	6.0	-14.4	<b>4.1</b>	5.6	-22.5	<b>3.1</b>
	800	8.1	-20.9	<b>5.4</b>	8.8	-29.6	<b>5.2</b>
	900	8.5	-32.3	<b>4.6</b>	9.4	-37.6	<b>4.9</b>
	1000	12.1	-39.8	<b>7.1</b>	14.2	-42.1	<b>8.7</b>
	1100	12.6	-44.9	<b>6.8</b>	13.4	-46.7	<b>7.4</b>
	1200	9.2	-48.3	<b>3.3</b>	11.8	-51.1	<b>5.4</b>
	1300	7.1	-48.7	<b>1.3</b>	12.0	-49.9	<b>5.5</b>
1400	10.2	-45.6	<b>4.1</b>	10.5	-46.3	<b>4.3</b>	



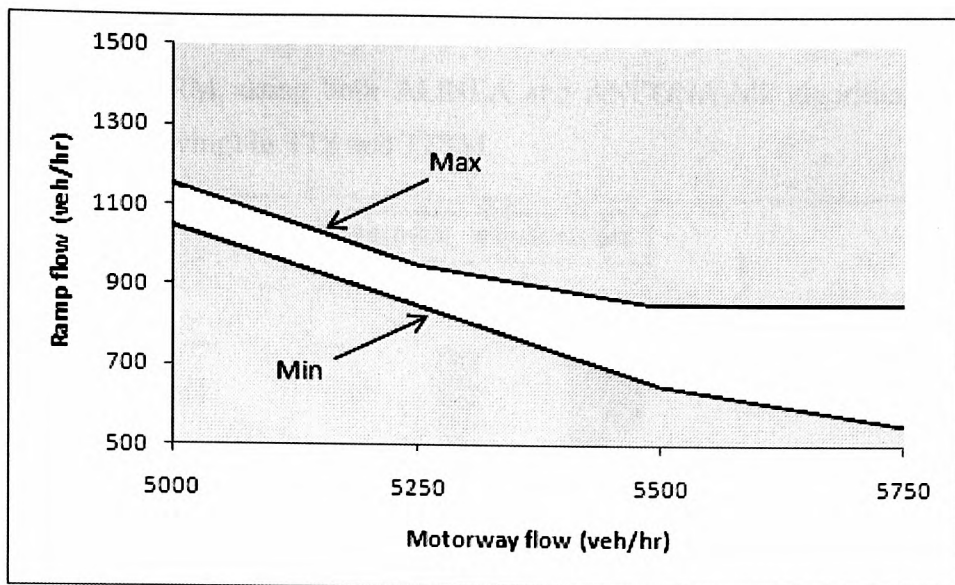

60 minutes' peak period

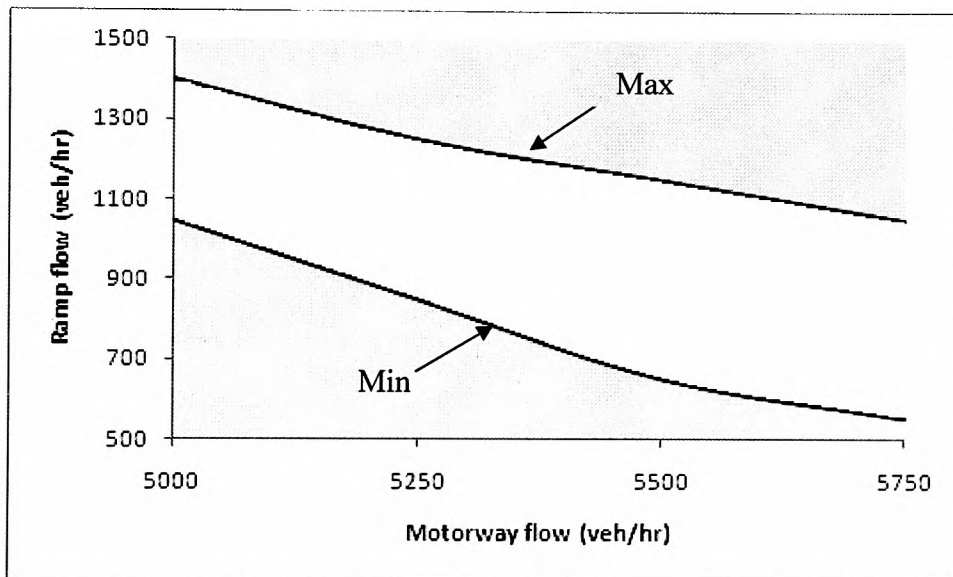

30 minutes' peak period

Figure 8-32 Ranges of flows at which RM is effective in reducing the TTS

### 8.5.3. Effectiveness of RM with a one lane ramp section

Some ramp sections consist of only one lane, as in the case of the M62 J11. The effectiveness of RM in such a case has been investigated using a motorway flow of 5500 veh/hr with different values of merge flow rates and with two peak periods of 30 and 60 minutes.

The simulation results for the 60 minutes' peak period, as shown in Figure 8-33, revealed a significant increase in TTSR and TTS (i.e. negative time saving) with slight decrease in TTSM values at limited flow rates. This suggests that there is no benefit in using RM with such a limited storage section in such peak periods.

The simulation results for the 30 minutes' peak period are shown in Figure 8-34. The figure suggests the RM, using both ALINEA and ANCONA-M2 algorithms, produced some benefit (time saving) in TTS and TTSM.

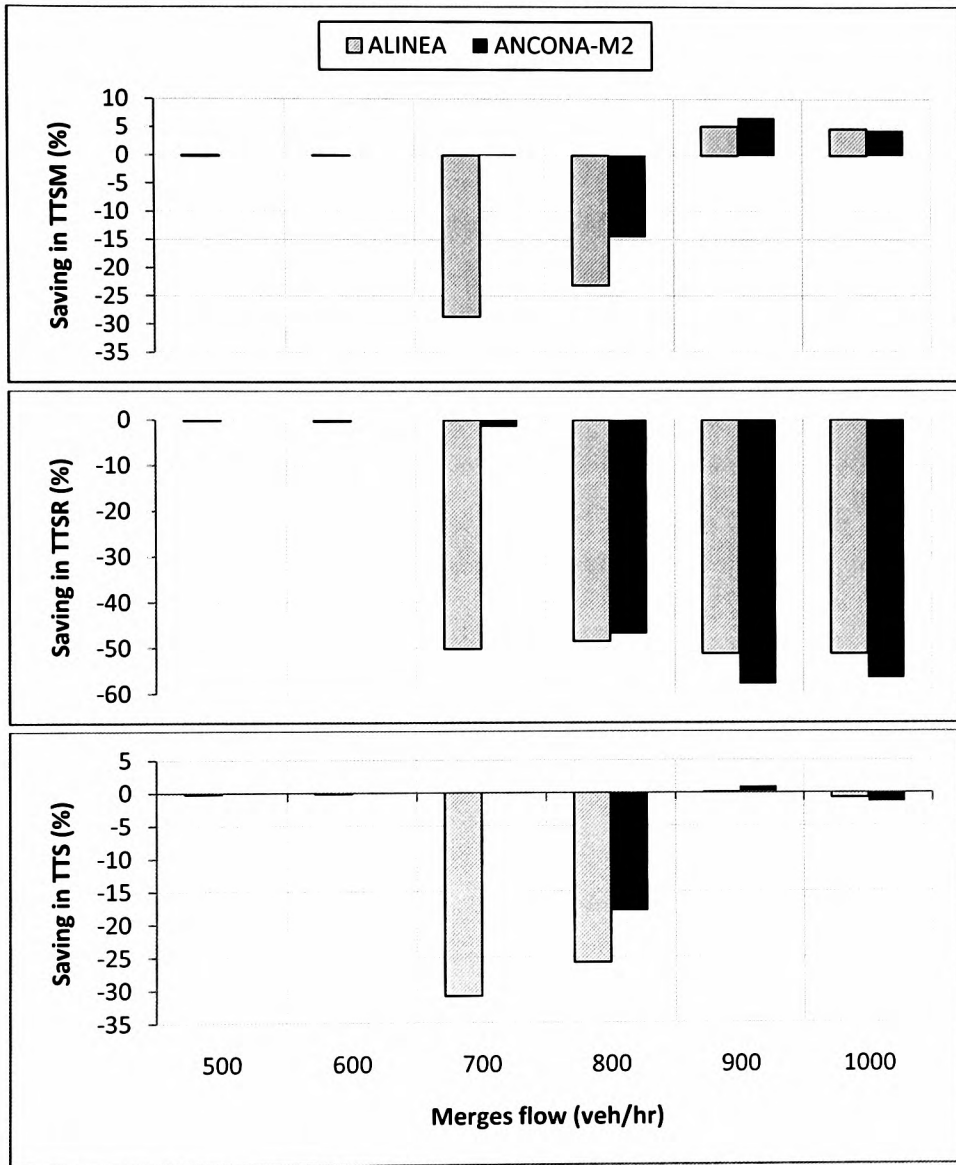

Figure 8-33 Savings in TTSM, TTSR and TTS obtained from a single lane ramp section with a 60 minutes' peak period

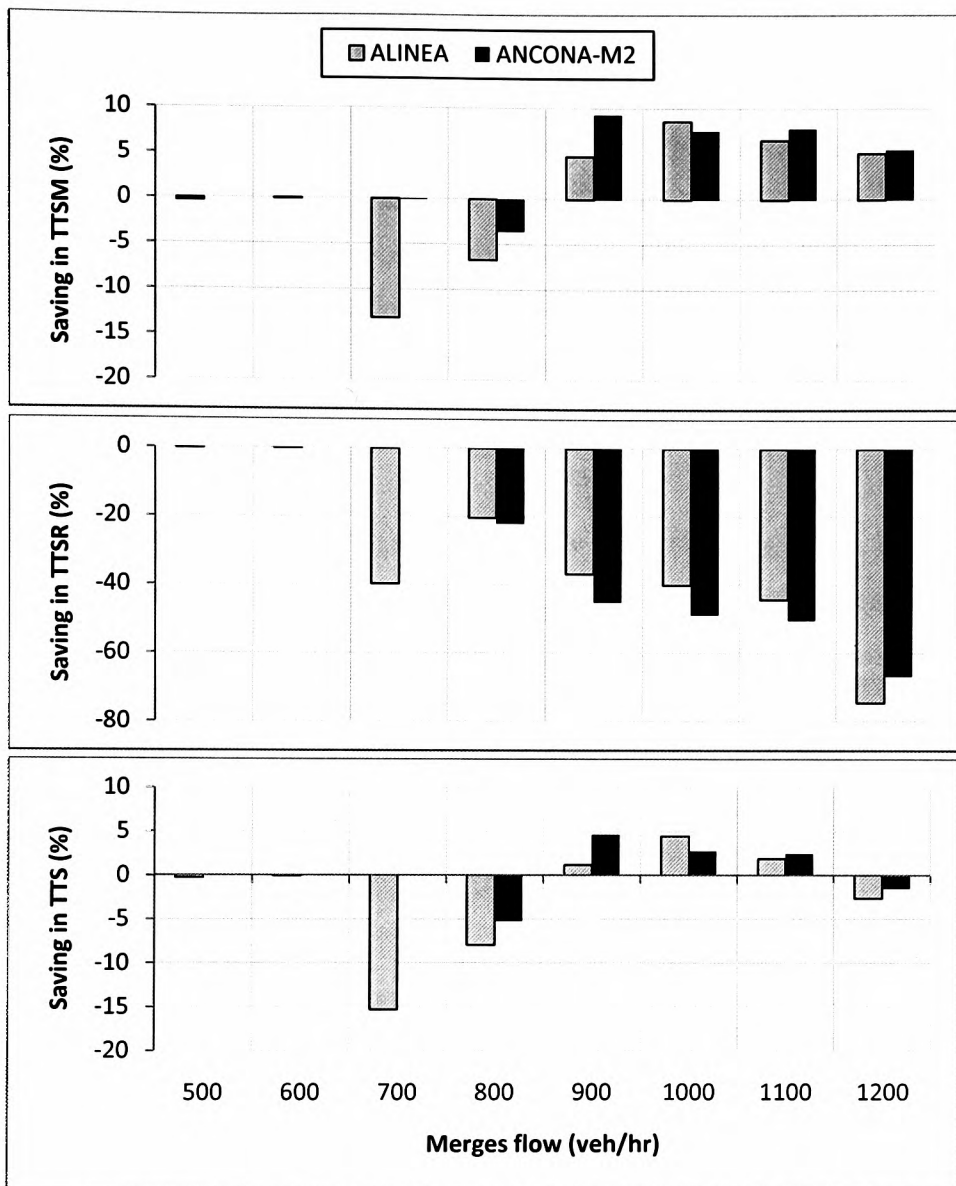

Figure 8-34 Savings in TTSM, TTSR and TTS obtained from a single lane ramp section for a 30 minutes' peak period

#### 8.5.4. Effectiveness of RM with further downstream bottlenecks

In some cases, RM is designed to control the bottleneck produced by further downstream bottlenecks. An example of such a case is when the number of lanes is reduced after the merge section or where there is another downstream merge/diverge section. The M56 J2 merge section is a real example of such a case where RM is installed in the section in order to control the bottleneck produced from merging the M56 with the M60 after a distance of more than 1 km downstream from the M56 J2 (Highway Agency, 2008).

In order to test the effectiveness of RM under such circumstances, the ghost island merge section layout which is included in the model has been used as shown in Figure 8-35. The spacing between the two merges has been set as 600m (the clear spacing from the end of

merge 1 to the starting of merge 2). The RM has been modelled in the first merge section “Merge 1” in order to control the bottleneck produced downstream (i.e. from the second merges section “Merge 2”). The same position of the downstream detectors (i.e. downstream of “Merge 1”) is applied for both the ALINEA and the ANCONA-M2 algorithms since this downstream location could reasonably serve both algorithms as it will be downstream of the merge section for the ALINEA algorithm and upstream of the bottleneck location for the ANCONA-M2 algorithm. The RM effectiveness has been tested using two values for the position of the loop detectors of 100m and 200m upstream of “Merge 2”.

The motorway flow rates of 5250 and 5500 veh/hr have been used with different merge flow rates which are assumed to be equally distributed between the two merge sections.

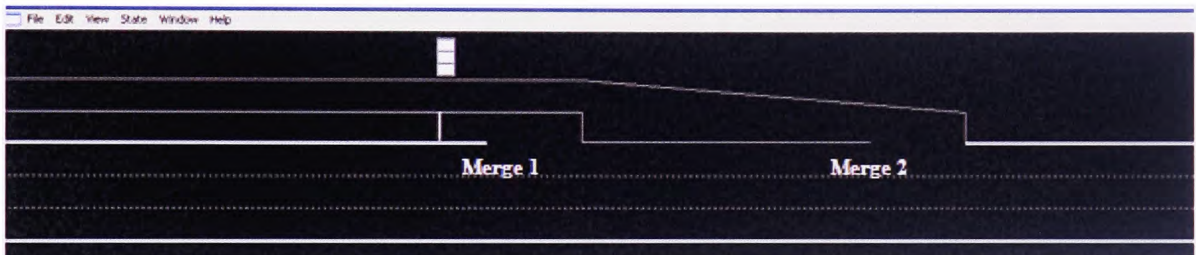

Figure 8-35 A snapshot from the model showing the geometry of the two merge sections

When the position of the loop detectors of 100m is applied, the results shown in Figure 8-36 suggest the ability of the RM system using both the ALINEA and ANCONA-M2 algorithms in reducing the TTSM. However, the ALINEA algorithm as shown in the figure has a negative impact on the total time spent (TTS).

By using the loop detectors at 200m upstream of “Merge 2”, the results obtained from the ALINEA algorithm for both the TTS and TTSM are better than those obtained from the ANCONA-M2 algorithm as shown in Figure 8-37.

The results suggest that the ALINEA algorithm is more effective in cases where the location of its loop detectors is not far away (in the downstream direction) from the location of the RM signals. In addition, the ANCONA-M2 algorithm becomes less efficient if the location of its loop detectors is far away (in the upstream direction) from the bottleneck location. This may be due to the spilling back of the traffic congestion for a further distance before triggering the RM which increases the difficulty of recovering normal traffic conditions.

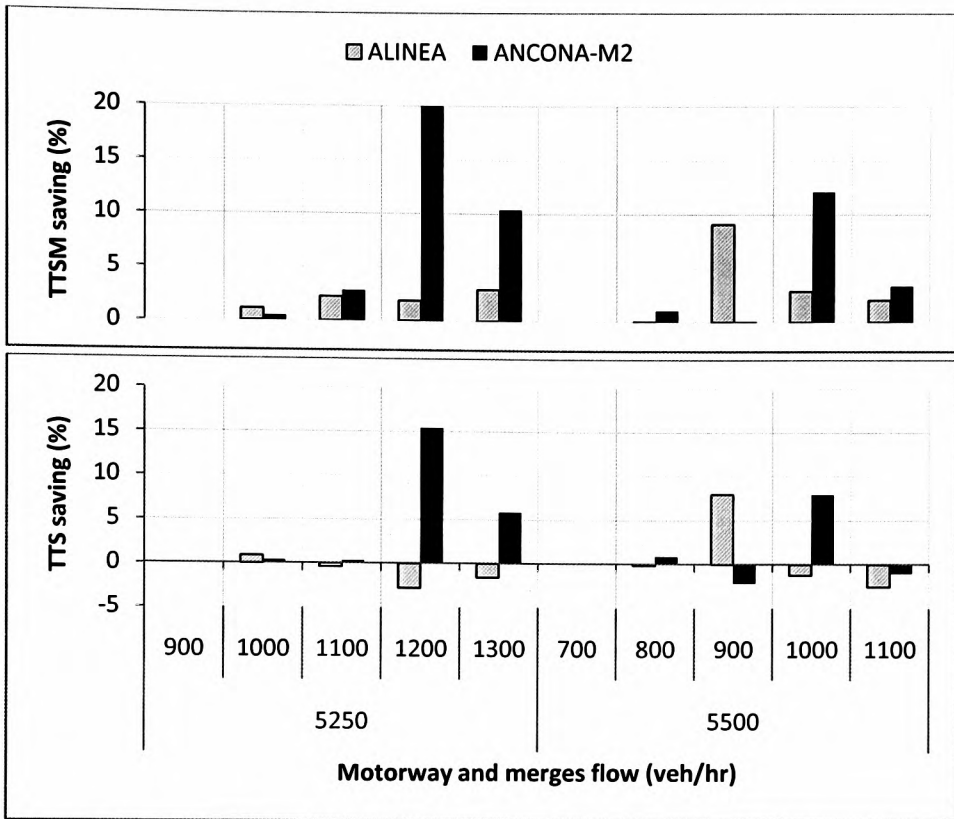

Figure 8-36 Effectiveness of RM with detectors position at 100m upstream of merge 2

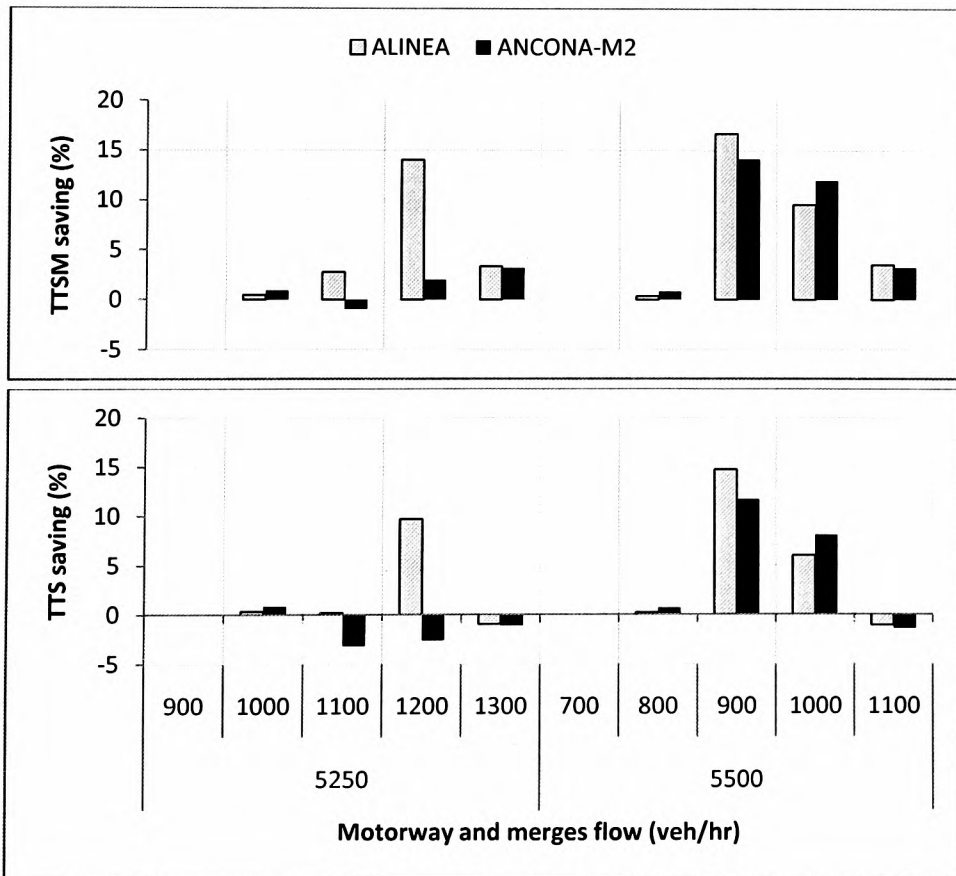

Figure 8-37 Effectiveness of RM with detectors position at 200m upstream of merge 2



### 8.5.5. Effect of traffic signals' position

The effect of the position of the traffic signals on time spent obtained from the ANCONA-M2 algorithm is shown in Figure 8-38. This figure suggests that no benefit has been obtained from moving the position of the traffic signals in an upstream direction because the increase in the position would mean a reduction in the storage length of the ramp section. This could explain why a reduction happened in the total time spent for merge traffic (TTSR) with an increase in the signal position as shown in Figure 8-38. However, installing the signals very close to the nose (50m or less) would increase the travel time of the motorway traffic as a result of merging traffic with low speeds.

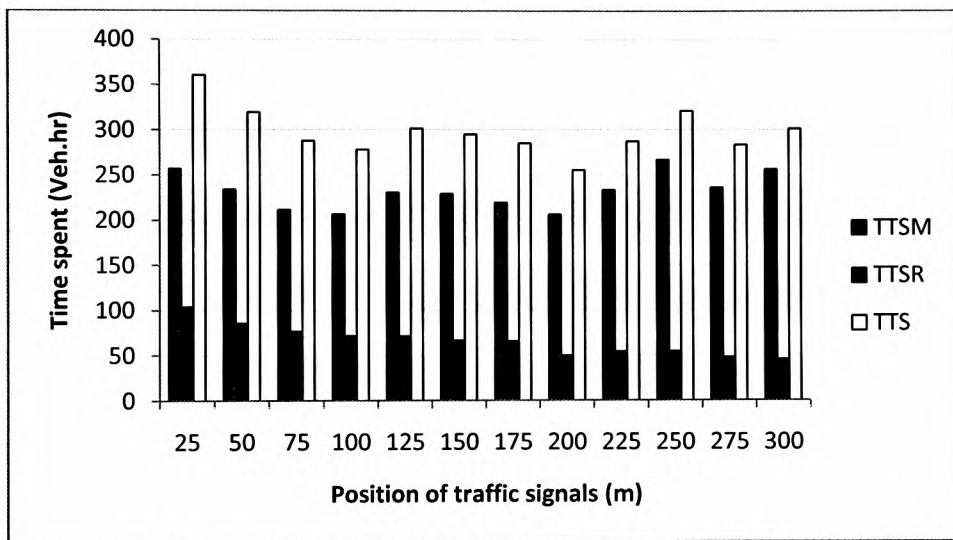

Figure 8-38 Effect of the position of the traffic signals on the time spent

### 8.5.6. Effect of total cycle length

Cycle length in a RM system is either fixed or variable. In the first approach, the green time is estimated based on the metering rate which is obtained from the RM logic every cycle. In the second (i.e. variable cycle length), the green period is constant and the duration of cycle length is calculated from the obtained metering rate. This section examines the fixed cycle length approach using different values for the total cycle length of 15, 30, 45, 60, 90 and 120 seconds. Three flow rates with three different seeds are used as shown in Table 8-8.

Table 8-8 Flow rates (veh/hr) that used in testing the effect of cycle length

$q_{in}$	$q_{ramp}$
5250	900
5500	700
5750	700

The results of TTS obtained from both the ALINEA and the ANCONA-M2 algorithms suggest that using a cycle length of up to 30 seconds is the optimum (see Figure 8-39 for the results obtained from the ALINEA algorithm).

Using higher values for cycle length (such as 45 seconds or higher) result in getting higher TTS values. This is because using such higher values is not efficient to operate RM based on instant traffic conditions and thus reduces the efficiency of RM. Moreover, using such higher cycle lengths will mean an increase in the red periods of the traffic signals. This will increase the length of the queues upstream of the stop line and hence increase the need to trigger the QOS. Figure 8-40 compares the queue lengths that were created by using cycle lengths of 30 and 120 seconds and suggests that the 120 seconds' value would significantly increase the cases where the queue lengths reach the maximum of about 30 vehicles and hence would increase the need to trigger the QOS.

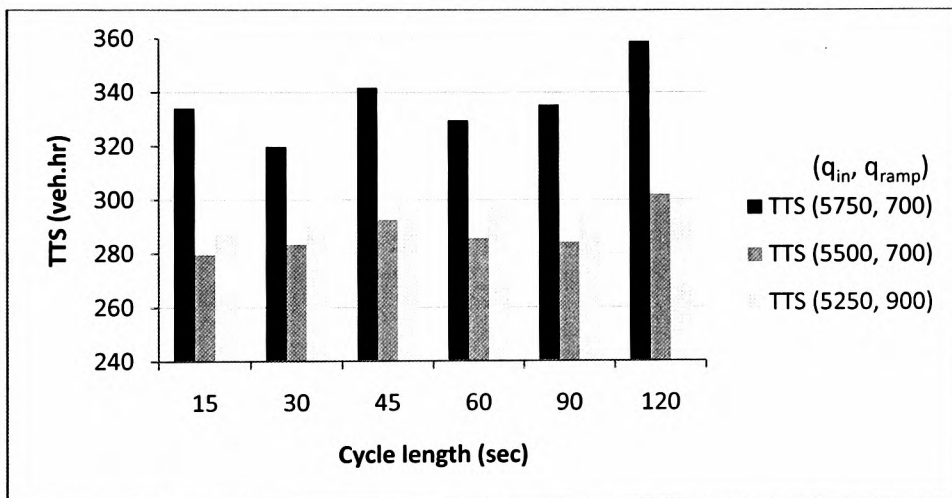

Figure 8-39 Effect of cycle length on travel time using the ALINEA algorithm

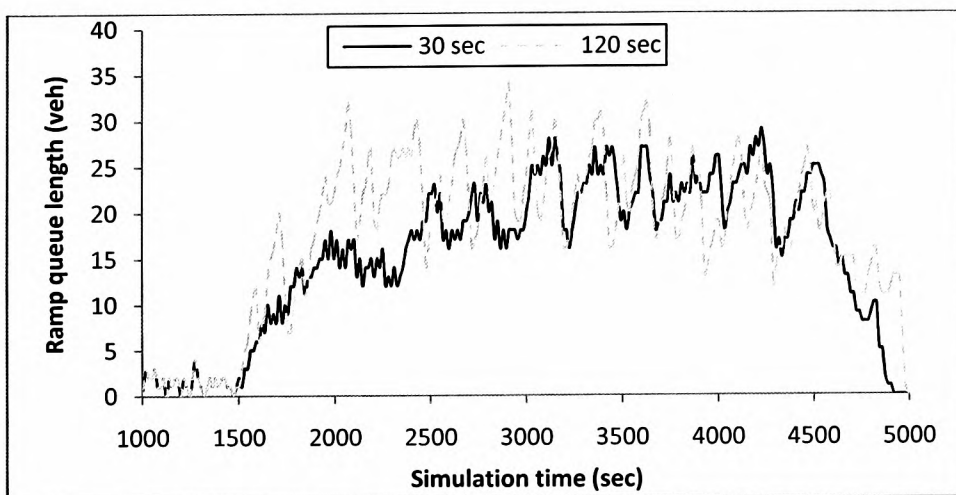

Figure 8-40 Queue lengths created upstream of the stop line

### 8.5.7. Testing of queue override strategies (QOSs)

Different procedures were suggested to deal with queues created upstream of the stop line of the traffic signals (see section 3.6.5). Using the flow rates given in Figure 8-2, the effect of the following QOSs on TTS has been tested:

QOS 1: Turning off the RM system when the measured occupancy at the queue override detectors (QOD) at the ramp entrance exceeds a threshold of 50% (commonly used in RM as discussed in section 3.6.5).

QOS 2: Using the X-ALINEA/Q algorithm which was proposed by Smaragdis and Papageorgiou (2003) as described in section 3.6.5.

QOS 3: Using the procedure adopted by Gordon (1996) as described in section 3.6.5. This QOS suggests increasing the metering rate to be a maximum of the metering rate derived from the RM logic and 900 veh/hr, in cases where the calculated occupancy as given by the QOD is 30% or higher. The RM will shut down in this scenario if the measured occupancy at the QOD exceeds a value of 50%.

QOS 4: Similar to that in QOS 3 above but with operating of 20 seconds' green time out of 30 seconds cycle length rather than turning off the RM system when the measured occupancy at the QOD exceeds a value of 50%.

The effect of these QOSs on the total time spent (TTS) is presented in Figure 8-41. This shows that for QOS 2 and QOS 4, provide slightly lower TTS values compared with QOS 1 and QOS 3. However, it is found the improvement in TTS that is offered by QOS 2 (i.e. the X-ALINEA/Q algorithm) is as a result of its failure in preventing queues from propagating upstream of the QOD at the ramp entrance. In other words, the QOS 2 offered improvement in motorway traffic conditions by allowing the queues (on the ramp section) from blocking other networks. This is clearly shown in Figure 8-42 that compares the occupancy measured at the QOD using QOS 2 and 4. The continuous high occupancy values obtained from the QOS 2, (see the circled part in Figure 8-42), indicates the failure of the QOS 2 in preventing ramp queues from exceeding the QOD.

The failure in the QOS 2 that was proposed by Smaragdis and Papageorgiou (2003) happened because, in some cases, when the queues reached the QOD (i.e. exceeding the position of the detectors used to calculate the entering the ramp flow) the flow registered by this detectors' station would be sharply reduced (due to the presence of queues). As a result, the queue length calculated by this method (as discussed in section 3.6.5) will be



highly inaccurate and therefore the metering rate derived from this method will not reflect the actual traffic conditions. This discussion is supported by Liu *et al.* (2009) who reported that such technique of estimating queue length is only applicable for queues which are shorter than the distance between stop line and the location of the loop detectors.

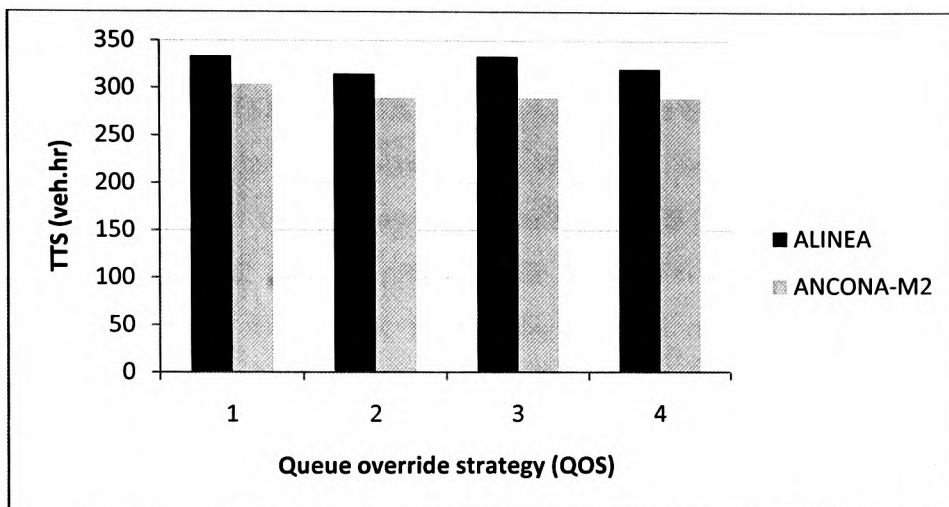

Figure 8-41 Effect of queue override strategies on TTS

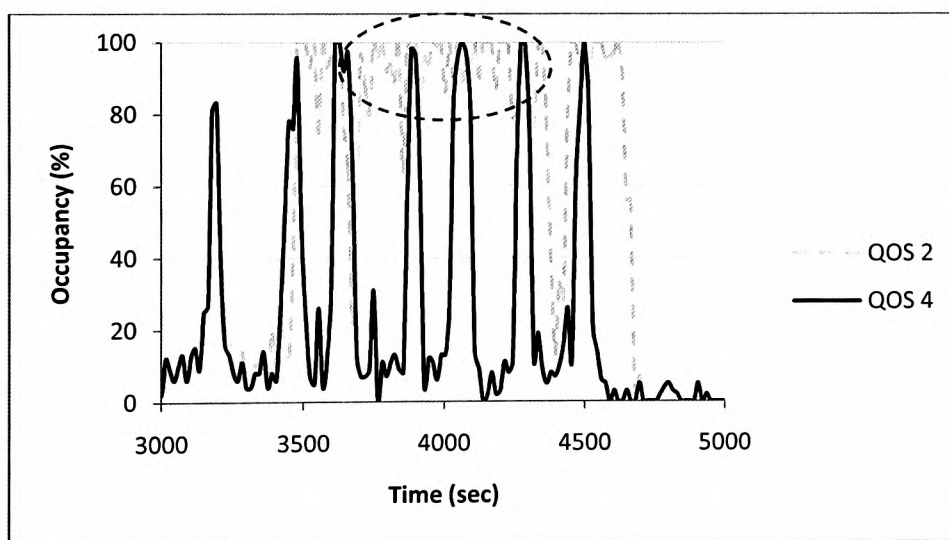

Figure 8-42 Occupancy obtained from the QOD

From the above, it could be concluded that although the X-ALINEA/Q override algorithm was extensively used in previous research for the simulation of RM to manage ramp queues (see for example, Papamichail and Papageorgiou (2008), Bai *et al.* (2009) and Papamichail *et al.* (2010)), the simulation results suggest that this QOS (i.e. QOS 2) is not recommended. In addition, QOSs 1, 3 and 4 are capable of preventing queues from exceeding the QOD and therefore these are recommended for use in practice.

## 8.6. Comparison between RM and LCR

A previous chapter has highlighted the positive impact of using LCR with “Scenario 1” using limited flow rates (as discussed in section 7.5.2). Therefore it was decided to test the impact of applying the LCR using the same flow rates (as given in Table 8-I) that were used in testing RM and to compare the results.

The results for TTSM, TTSR and TTS are shown in Figure 8-43. The figure reveals that the ANCONA-M2 algorithm gave lower TTSM values (i.e. higher savings in TTSM) than the LCR. For TTSR, the figure shows that, unlike the RM controls, the LCR have no significant effect on travel time for merge traffic. Therefore, positive TTS savings have been obtained by using these LCR for all the selected ranges of flow rates. Such reductions in the TTS could not even be obtained when using RM controls since these controls normally cause a significant increase in travel time for the merge traffic (as shown in the figure).

From the above, it could be concluded that using RM could be more beneficial than applying LCR when the objective is to minimise the travel time of motorway traffic without considering the additional delay produced for ramp traffic. If the objective is to reduce the overall traffic delay of motorway and merge traffic, then LCR may provide a better solution.

Other factors which require further consideration related to the nature of drivers and their compliant behaviour with the LCR. In addition, there might be limitations on how LCR could be implemented on motorway sites. This relates to clarity of signs and lane marking used for this purpose as well as the enforcement controls.

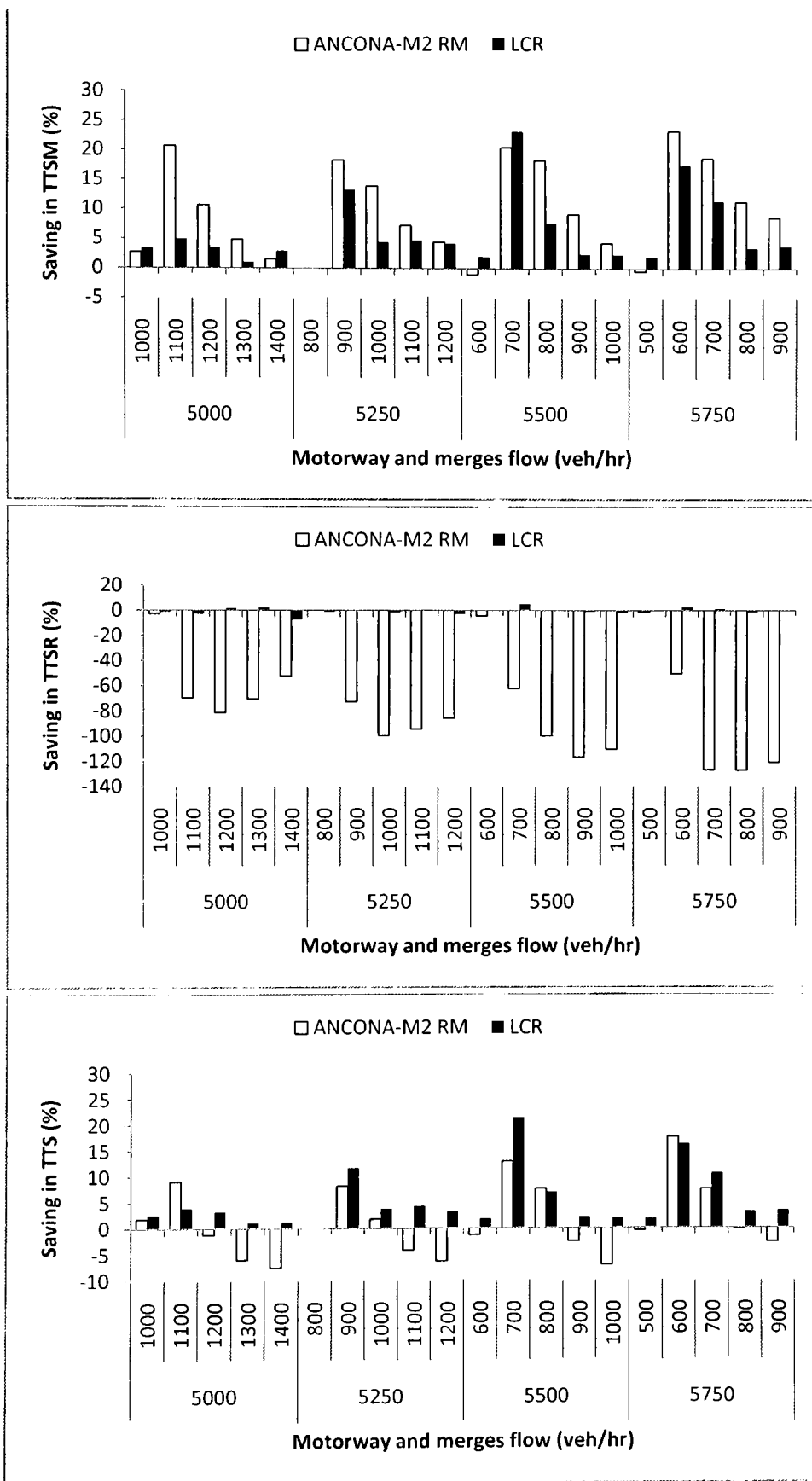

Figure 8-43 Comparing the time savings obtained by using LCR and RM

## 8.7. Summary

This chapter described the model applications that were conducted in testing some issues related to RM controls. The main points presented in the chapter could be summarised as follows:

- The optimum parameters for some of the RM algorithms (see section 8.2).
- Testing the effectiveness of applying the ALINEA, D-C, ANCONA and RMPS algorithms (see section 8.3).
- Development of the new RM algorithm to extend the logic of the ANCONA algorithm in order to deal with some limitations. The developed algorithms are the ANCONA-M1, ANCONA-M2, ANCONA-M3 and hybrid AL-AN algorithms (see section 8.4).
- The effect of ramp length on the effectiveness of RM (see section 8.5.1).
- The effect of having different durations for the peak periods of 15, 30, 60 and 90 minutes on the effectiveness of the ALINEA and ANCONA-M2 algorithms (see section 8.5.2).
- The effect of having only a one lane ramp section on the effectiveness of RM (see section 8.5.3).
- The effectiveness of applying RM in situations where RM is designed to control the congestion propagated from further downstream bottleneck locations (see section 8.5.4).
- The effect of the position of the traffic signals on the effectiveness of RM (see section 8.5.5).
- The effect of having different values for cycle lengths (see section 8.5.6).
- Testing some queue override strategies (QOSs) (see section 8.5.7).
- Comparing the results obtained from using LCR with those obtained by applying the ANCONA-M2 algorithm RM (see section 8.6).

## CHAPTER NINE : CONCLUSIONS AND FURTHER RESEARCH

### 9.1. Conclusions

#### 9.1.1. Data collection and analysis

- Over 4 million leader–follower pairs of real data taken from UK motorway sites were analysed to study the effect of vehicle types on close following behaviour (see section 4.4). The data have been filtered to ensure that “free flowing” vehicles are excluded from the analysis using a robust methodology for defining maximum gap headways and maximum speed differences. The main findings are as follows:
  - i. There is no evidence that the spacings between successive vehicles are significantly affected by the type (i.e. width) of the leader. This is in disagreement with the assumptions of the visual angle models and suggests that the validity of the models that use the effect of the size (width) of vehicles to represent real traffic behaviour is in question.
  - ii. The average following distances for all the speed ranges have been compared with those distances obtained from applying some theoretical models such as using the 2 seconds’ rule or leaving a safe stopping distance as recommended by the official Highway Code (2010). The results suggest that these theoretical models are not adhered to by the majority of UK drivers.
- Motorway Incident Detection and Automated Signalling (MIDAS) data, taken from many locations on different motorway sites, have been the main source of data used in order to study how traffic flow is distributed among the available number of lanes for a directional movement (i.e. lane utilisation). The main findings as follows: (see section 4.5 for further details)
  - i. New lane utilisation models for motorway sections with two, three and four lanes have been developed (see section 4.5.2). These models could be used as inputs to micro-simulation models. In addition, some previous lane utilisation models have been tested and the results suggest the need to develop new models.
  - ii. Lane utilisation coefficients derived from sections further upstream of merge sections have been compared with the coefficients obtained from detectors just

upstream of the merge section. The results revealed some evidence concerning the tendency of motorway drivers to shift (yield) towards the offside lane when approaching the merge section (see section 4.5.3).

- iii. Lane utilisation coefficients derived from sections just downstream of a merge section have been compared with those coefficients obtained from normal sections. The results revealed some evidence concerning the tendency of drivers to maintain close following behaviour in the vicinity of the merge sections (see section 4.5.3).
  - iv. New models for HGVs' lane utilisation have been developed for motorway sections with three and four lanes. These new models considered the combined effect of total motorway flow and total HGVs' flow (see section 4.5.5).
- A sample of about 60,000 vehicles has been analysed (see section 5.6.2) in order to test the distribution of the lengths of cars and HGVs. The results suggested that these two categories have similar means to those described by El-Hanna (1974). However, using a normal distribution to describe the lengths of cars and HGVs (as has been applied by many studies in UK) is not appropriate based on statistical tests.
  - Data taken from motorway sections with three lanes have been used in order to fit some headway distribution models (see section 4.6). The selected models are the shifted negative, the double exponential and the generalised queuing models. The results suggest that both the shifted negative exponential and the double exponential models could be used for flow rates up to 1750 veh/hr. The generalised queuing model gives better results for higher flow rates. In fact, no specific distribution is found to represent the whole ranges of flow rates (i.e. free to high flows).
  - Video recordings collected from motorway merge sections were used to get a better understanding of drivers' behaviour in terms of the interactions between motorway and merge traffic (see section 4.8). The main conclusions are:
    - i. Nearly 85% of drivers start their merging manoeuvring within the first 50m of the auxiliary lane.
    - ii. The cases where traffic has to stop at the end of the auxiliary lane before merging are minimal. This has been observed with different traffic conditions.
    - iii. The cooperative behaviour of motorway drivers (i.e. allowing others to merge in front of them either by decelerating or by shifting (yielding) behaviour into other lanes) is pronounced for different levels of flow rates and is not only limited to congested situations.

- iv. Most merging drivers accept the first available gap when they reach the auxiliary lane.
  - v. No real priority has been observed for motorway traffic over merging traffic. In fact, observations support the finding of Hounsell and McDonald (1992) who suggested that the priority is more pronounced in favour of merge traffic.
  - vi. In congested situations the priority of movements tends to be “merge in turn” between motorway lane 1 and the merge traffic (see Figure 2.5 for the definition of lane 1).
- MIDAS and also some video recordings data taken from some RM sites in the UK have been analysed and the following conclusions have been obtained (see section 4.9).
    - i. Critical occupancy values have been obtained for motorway sections with 2, 3 and 4 lanes (see section 4.9.1). These critical values are obtained using data taken from loop detectors located downstream of the merge sections. The critical occupancy parameter is important in the operational procedure for RM controls.
    - ii. Video recordings data for the M56 J2 suggest that drivers are fully compliant with the red periods of traffic signals but have a tendency to use the amber period in the same way that they use the green times (see section 4.9.2).
    - iii. RM is not able to prevent congestion from spilling back upstream from the merge sections (see section 4.9.3).

### 9.1.2. Model development

- A new micro-simulation model for motorway merge and normal sections has been developed based on car-following, lane changing and gap acceptance rules.
- The developed merging rules (see section 5.9.2) considered the following interactions between motorway and merge traffic:
  - i. The acceleration/deceleration behaviour of merging traffic with respect to the speed of the nearest lane of a motorway (i.e. lane 1) at the approach of the merge section.
  - ii. The adjustment (i.e. acceleration/deceleration) behaviour of merging traffic with respect to the available sizes of lead and lag gaps. This means that a multi-decision process is considered when, for example, a driver accepts the lead gap and rejects the lag gap.
  - iii. The cooperative nature of drivers in allowing others to merge in front of them either by decelerating or shifting to other lanes in the vicinity of the merge sections.

- iv. The “relaxation” process and the effect of close following behaviour after merging.
- v. The developed rules showed good agreement with the real data. In addition, it is found the developed model is capable of representing the fact that merging traffic seldom stops at the end of the acceleration (i.e. auxiliary) lane, as observations from a variety of sites suggest.

### 9.1.3. Model applications (without the use of RM)

- The model has been applied to investigate factors affecting the capacity of merge sections for motorway sections with 2- and 3- lanes. The following conclusions have been derived (see section 7.2):
  - i. The effect of having different proportions of HGVs on motorway capacity has been tested and regression equations were developed from the simulation (see section 7.2). The developed equation for motorways with two lanes has been compared with real traffic data and showed good agreement.
  - ii. The conversion of HGVs to passenger car units (pcu) has been tested and the simulation results suggest a passenger car equivalency factor (PCE) of 2.0.
- The capacity of a motorway merge section is reduced when the ratio of merge to motorway traffic increases (see section 7.3).
- The effect of cooperative behaviour, for some selected flow rates, on travel time was tested (see section 7.4). The results suggested that the cooperative nature of drivers can reduce travel time for both motorway and merge traffic. Such an effect on the travel time for motorway traffic is linked to the reduction in the cases of merging from stopping conditions.
- The effect of applying speed limits and lane changing restrictions (LCR) at the approach to merge sections (see section 7.5) on travel time was tested. The following conclusions have been obtained:
  - i. By testing speed limit values of 70, 80 and 90 km, the results revealed that the values of 70 and 80 km/hr could inversely affect traffic conditions by increasing travel time. The use of 90 km/hr slightly reduced travel time compared with the cases of without controls.
  - ii. Applying LCR by preventing all lane changes within merge sections has significantly increased the travel time.



- iii. Travel time was reduced when applying the LCR by allowing drivers on lane 1 to shift into the middle lane whenever possible, while restricting lane changes between the middle and the offside lanes within the section (see section 7.6.2).

#### 9.1.4. Model applications (with RM)

The model was applied to test the following related issues with a RM design and its effectiveness for motorway sections with three lanes.

- The optimum parameters for the ALINEA, D-C, RMPS and ANCONA algorithms were obtained (see section 8.2). The desired occupancy of 23% with respect to the position of the loop detectors of 300m downstream of the merge section has been selected for the ALINEA and D-C algorithms. For the ANCONA algorithm, the “congestion indicator” parameter was found to be 60 km/hr.
- A better understanding of the effect of RM design parameters were presented from a sensitivity analysis study covering wide ranges for each parameter (see section 8.2).
- Testing the effectiveness of applying the ALINEA, D-C, RMPS and ANCONA algorithms suggested the following (see section 8.3):
  - i. These algorithms are capable of reducing the time spent for motorway traffic (TTSM) but it significantly increases the time spent by the merging traffic (TTSM). The overall benefits of implementing RM in reducing total time spent (TTS) is limited in situations where the sum of the motorway and merge flows is just over the capacity of the downstream section. It is also found that RM is not really beneficial for cases where the total upstream flows (i.e. motorway and merge traffic) are lower than the downstream capacity.
  - ii. The results obtained suggest that the ANCONA algorithm could significantly reduce the TTS compared with the ALINEA, D-C and RMPS algorithms.
  - iii. The ANCONA algorithm is more efficient in situations when there are no ultimate needs to trigger RM.
- Some improvements for the ANCONA algorithm have been suggested to cover some limitations and to enhance the algorithm further (see section 8.4). The results of testing these new algorithms suggest that they could improve the application of RM through increasing the saving in time spent. The developed algorithms are:

- i. ANCONA-M1 in order to enhance the shutting down criteria and which uses a third metering rate in cases where the speed upstream of the merge section significantly increases above the “congestion indicator”
  - ii. ANCONA-M2 which uses different metering based on different speed levels.
  - iii. ANCONA-M3 which includes the ramp flow rates on the metering rates used.
  - iv. ALINEA-ANCONA hybrid algorithm (AL-AN) which combines both the ALINEA and the ANCONA algorithms.
- The effect of ramp length on the effectiveness of RM has been investigated (see section 8.5.1). In general, the results show that RM could allow higher speed rates on motorway sections if there is enough storage length (e.g. motorway to motorway RM). For limited storage lengths, the longer the ramp section is, the better it is for motorway traffic. The results reveal that increasing storage length will lead to increasing delays for the merging traffic.
  - The effect of having different durations for the peak period of 15, 30, 60 and 90 minutes on the effectiveness of the ALINEA and ANCONA-M2 algorithms was tested (see section 8.5.2). The results suggested that the benefit of RM could be extended to wider ranges of flow rates for relatively short peak durations such as 15 and 30 minutes compared with the 60 minutes’ peak period scenario. For long peak durations such as 90 minutes, the use of RM will cause an increase in the TTS compared with the scenario of “without RM” The useful ranges of flow rates when RM could reduce the TTS for different peak periods have been obtained.
  - The effect of having only a one lane ramp section on the effectiveness of ALINEA and ANCONA-M2 has been tested (see section 8.5.3). Two peak periods of 30 and 60 minutes were used. For the case of the 60 minutes’ peak period, the results suggested that there is no benefit in using RM in such a limited storage section whereas some benefit has been achieved in the case of the 30 minutes’ peak period.
  - The effectiveness of applying ALINEA and ANCONA-M2 in situations where RM is designed to control the congestion spilling back from further downstream locations has been investigated (see section 8.5.4). The results suggested that both algorithms are capable of reducing TTS for the tested flow rates.
  - No clear effect regarding the positioning of traffic signals has been obtained on the effectiveness of RM (see section 8.5.5). This may be due to the fact that any change to

the signal position will result in a change to the storage length (i.e. by moving the signal position further upstream on the ramp will mean a reduction in storage length).

- The effect of having different values for cycle lengths has been tested (see section 8.5.6). The results show that cycle lengths such as 30 seconds or less are better than using higher values.
- Some queue override strategies (QOS) have been tested (see section 8.5.7). The main finding is that the X-ALINEA/Q strategy which was proposed by Smaragdis and Papagergiou (2003) is not capable of preventing queues on the ramp section from propagating upstream into other networks.
- The results obtained from using LCR were compared with those obtained from applying ANCONA-M2 for RM systems (see section 8.6). The results show that RM could reduce the TTSM more efficiently than LCR but with a significant increase in the TTSR and hence the efficiency of RM in reducing the TTS is limited. On the other hand, LCR could reduce the TTSM without affecting the TTSR and hence the TTS is reduced also. Therefore, it could be concluded that if the problem is only to reduce travel time for motorway traffic (i.e. TTSM), the use of RM controls is more efficient. However, if the overall travel time is considered (i.e. TTS), the use of LCR could provide better results than using RM.

## **9.2. Recommendations and further research**

### **9.2.1. Data collection and analysis**

- While traffic loop detectors that are located at regular intervals on motorway sections provide useful average one-minute data, such data do not help in estimating some specific microscopic parameters. These include headways and speed distributions, vehicle lengths and the spacing between successive vehicles. Therefore, there is a need to extract raw data that could be obtained from the detectors before it was averaged in order to be similar to the individual vehicles' raw data that was used in this study from the M42 and M25 motorway sites. In addition, there is a need to decrease the intervals (distance) between the loop detectors within merge sections in order to get a much better understanding of the interactions between motorway and merge traffic.
- For RM sites, there is no data available from loop detectors that are used in operating the QOS strategy. The availability of such data would help in estimating the delay for

merge traffic during the operation of RM and would also help in the validation process of simulation models for further implementations of such models.

- There is a need to examine the acceleration/deceleration rates' abilities of vehicles since the data used are mainly taken from other countries. Such data cannot be obtained without having detailed trajectory data for a sufficient section length.

### **9.2.2. Enhancing the developed simulation model**

While the results obtained from the model were reasonably close to real data, there were still some improvements that could be made to get better results. Such improvements have not been conducted due to time limitations and could be summarised as follows:

- i. Some of the model parameters were obtained from previous research (e.g. the relaxation period) or were obtained from using a deterministic approach (without considering their distributions, e.g. maximum deceleration rate). This happened because there was a lack of suitable data and was related to the difficulties in estimating such parameters from real sites. Therefore, it might be useful to test different values/distributions to enhance the simulation results.
- ii. It might be useful to use other categories of vehicle types rather than only using cars and HGVs. However, such additions would require more detailed information for the acceleration and deceleration abilities of the added groups.

### **9.2.3. Modelling of RM**

The developed model has been used in evaluating some of the widely used RM algorithms. However, these are still some points which were not covered due to time limitations. Therefore, further studies are required on the following issues:

- i. Testing the effectiveness of some other local RM algorithms such as PI-ALINEA, AD-ALINEA and UP-ALINEA.
- ii. Testing the effect of having a coordinated RM system for a motorway network.
- iii. Testing the combined effect of lane changing restrictions (LCR) and RM.

### **9.2.4. Practical implementations**

The application chapters have suggested some traffic management control in order to reduce travel time such as the use of LCR with scenario 1 (see section 7.5.2) and the use of ANCONA RM or one of its derivatives (see section 8.4). It might be useful to test these controls on real sites to show their effects.

## References

- Ackroyd, L. W., Madden, A. J., and Ernest-Jones, S. R. (1973) 'A Study of Vehicle Merging Behaviour at Rural Motorway Interchanges', *Traffic Engineering + Control*, 15(3), pp 192-195.
- Adebisi, O. and Sama, G. N. (1989) 'Influence of stopped delay on driver gap acceptance behaviour', *Journal of Transportation Engineering*, 115(3), pp 305-315.
- Ahmed K.I. (1999) *Modeling drivers' acceleration and lane changing behaviour*. PhD thesis, Department of Civil and Environmental Engineering, MIT, USA.
- Al-Obaedi, J. and Yousif, S. (2011) 'Micro-simulation model for motorway merges with ramp metering controls', Accepted for publication in *IEEE Transactions on Intelligent Transport System*, DOI: 10.1109/TITS.2011.2169792.
- Al-Obaedi, J. and Yousif, S. (2009) 'The use of visual angle in car following traffic micro-simulation models', *9th International Postgraduate Research Conference*, pp 533-545.
- Aycin, M. F. and Benekohal, R. F. (2001) 'Stability and performance of car-following models in congested traffic', *Transportation Engineering*, 127(1), pp 2-12.
- Bai, X., Zhao, D. and Yi, J. (2009) 'ADHDP( $\lambda$ ) strategies based coordinated ramps metering with queuing consideration', *IEEE Symposium of Adaptive Dynamic Programming and Reinforcement Learning*, Nashville, USA.
- Barceló, J. and Casas, J. (2002) 'Dynamic network simulation with AIMSUN', in *Int. Symp. Transport Simulation*, Yokohama, Japan, pp 1-25.
- Bar-Gera, H., Ahn, S. (2010) 'Empirical macroscopic evaluation of freeway merge-ratios', *Transportation Research: C*, 18(4), pp 457-470.
- Bellemans, T., De Schutter, B. and De Moor, B. (2006) 'Model predictive control for ramp metering of motorway traffic: A case study', *Control Engineering Practice*, 14(7), pp 757-767.
- Ben-Akiva, M., Cuneo, D. and Hasan, M. (2003) 'Evaluation of freeway control using a microscopic simulation laboratory', *Transportation Research: C*, 11(1), pp 29-50.
- Benekohal, R. F. (1986) *Development and validation of a car following model for simulation of traffic flow and traffic wave studies at bottleneck*, PhD thesis, the Ohio state university.
- Bennett, C. R. (1994) *A Speed prediction model for rural two-lane highways*. PhD Thesis. The University of Auckland, New Zealand.
- Bham, G. H. and Benekohal, R.F. (2004) 'A high fidelity traffic simulation model based on cellular automata and car-following concepts', *Transportation Research: C*, 12(1), pp 1-32.
- Brackstone, M. and McDonald, M. (1993) 'An instrumented vehicle for microscopic monitoring of driver behaviour', *IEEE IEE Vehicle Navigation & Information Systems Conference*, Ottawa.
- Brackstone, M. and McDonald, M. (1999) 'Car following: a historical review', *Transportation Research: F*, 2(4), pp 181-196.
- Brackstone, M. and McDonald, M. (2007) 'Driver headway: How close is too close on a motorway', *Ergonomics*, 50(8), pp 1183-1195.
- Brackstone, M., McDonald, M. and Wu, J. (1998) 'Lane changing on the motorway: Factors affecting its occurrence and other implications', *9th International Conference on Road Transport Information and Control*, No. 454, pp 160-164.

- Brackstone, M., Waterson, B. and McDonald, M. (2009) 'Determinants of following distance in congested traffic', *Transportation Research: F*, 12(2), pp 131-142.
- Branston, A. (1976) 'Models of single lane time headway distributions', *Transportation Science*, 10(2), pp 125-148.
- Brockfeld, E., Kuhne, R. D. and Wanger, P. (2005) 'Calibration and validation of microscopic models of traffic flow', *Transportation Research Record*, Vol. 1934, pp 175-187.
- Burghout, W. (2004) *Hybrid microscopic-mesoscopic traffic simulation*, PhD dissertation, Royal institute of technology, Sweden.
- Burghout, W., Koutsopoulos, H. V. and Andersson, I. (2005) 'Hybrid microscopic-mesoscopic traffic simulation', *Transportation Research Record*, Vol. 1934: 218-225.
- Burrow, I. J. (1974) 'Speed of cars on Motorways in England', *Transportation Science*, 10(2), pp 125-148.
- Carlson, R. C., Papamichail, I., Papageorgiou, M. and Messmer, A. (2010) 'Optimal mainstream traffic flow control of large-scale motorway networks', *Transportation Research: C*, 18(2), pp 193 - 212.
- Cassidy, M. J. and Rudjanakanoknad, J. (2005) 'Increasing the capacity of an isolated merge by metering its on-ramp', *Transportation Research: B*, 39(10), pp 896-913.
- Cassidy, M.J., and Ahn, S. (2005) Driver turn-taking behaviour in congested freeway merges, *Transportation Research Record*, Vol. 1934, pp 140-147.
- Chakroborty, P., Kikuchi, S. (1999) 'Evaluation of the general motors based car-following models and a proposed fuzzy inference model', *Transportation Research: C*, 7(4), 209-235.
- Chin, H. C. (1983) *A computer simulation model of traffic operation at roundabouts*, PhD Thesis, University of Southampton, UK.
- Choudhury C. F. (2007) *Modeling driving decisions with latent plans*, PhD thesis, Massachusetts Institute of Technology, USA.
- Choudhury C. F., Ramanujam, V. and Ben-Akiva, M. (2009) 'Modeling of acceleration decisions for freeway merges', *Transportation Research Board*, Vol. 2124, pp 45-57.
- Chu, L., Recker, W. and Yu, G. (2009) *Integrated ramp metering design and evaluation platform with Paramics*, Final report, ISSN 1055-1425, California Path Program.
- Ci Y., Wu, L., Pei, Y. and Ling, X. (2009) 'Gap acceptance capacity model for on-ramp junction of urban freeway', *Journal of Transportation Systems Engineering and Information Technology*, 9(4), pp 116-119.
- Clark, J. and Daigle, G. (1997) 'The Importance of simulation Techniques in ITS research and analysis', *Proceedings of the 1997 Winter Simulation Conference*, USA.
- Cohen, S. L. (2004) 'Application of relaxation procedure for lane changing in microscopic simulation models', *Transportation Research Board*, Vol. 1983, pp 50-58.
- Cunagin, W.D. and Chang, E.C. (1982) 'Effects of trucks of freeway vehicle headways under off-peak flow conditions', *Transportation Research Record*, No. 869, pp 54-59.
- Daganzo C.F. (1981) 'Estimation of gap acceptance parameters within and across the population from direct roadside observation', *Transportation Research: B*, 15(1), pp 1-15
- Dawson, R. F. and Michael, K. L. (1966) Analysis of on ramp capacities by Monte Carlo simulation, *Highway Research Record*, No. 118, pp 1-20.
- Department for Transport (2009) *Transport trends*, National statistics, UK.

- Department for Transport (DfT) (2010) *The official Highway Code*, UK.
- Dowling, R., Skabardonis A., & Alexiadis, V. (2004) *Traffic analysis toolbox: volume III: Guidelines for applying traffic micro-simulation modeling software*, FHWA-HRT-04-040. McLean, VA: Federal Highway Administration.
- Drew, D. R. (1971) *Traffic flow theory and control*, McGraw-Hill Book, New York.
- Drew, D. R., LaMotte, L. R., Buhr, J. H. and Wattleworth, J. A. (1967) 'Gap acceptance in the freeway merging process'. *Highway Research Record*. No. 208: 1-36.
- Duncan G.I. (1995) 'PARAMICS wide area microscopic simulation of ATT and traffic management'. *28th ISATA Conference*, Stuttgart, Germany.
- Duncan N. C. (1976) 'Rural speed-flow relations', *Transportation and Road Research Laboratory*, LR 705.
- El-Hanna, F. I. H. (1974) *An evaluation of highway intersection gap acceptance metering system*, PhD thesis, University of Bradford, UK.
- Endo, G., and V. Janoyan (1991) 'The Santa Monica Freeway Smart Corridor Project', *Compendium of Technical Papers, District 6, 44th Annual Meeting*, Institute of Transportation Engineers, 21-32.
- Federal Highway Administration (2004), *Traffic congestion and reliability: linking solutions to problems*, Cambridge Systematics, Inc.
- Federal Highway Administration (2007) *Traffic analysis toolbox, Vol. IV: Guidelines for applying CORSIM microsimulation modeling software*, No. FHWA-HOP-07-079.
- Ferrari, P. (1989) 'The effect of driver behaviour on motorway reliability', *Transportation Research: B*, 23(2), pp 139-150.
- Fox, P. and Lehman, F.G. (1967) *Safety in car following*, Newark, (N.J.), Newark college of Engineering.
- Fwa, T. F. and Li, S. (1995) 'Estimation of lane distribution of truck traffic for pavement design'. *Journal of Transportation Engineering*, 121(3), pp 241-248.
- Geistefeldt, J. (2011) 'Capacity effects of variable speed limits on German freeways', *Proceedings of the 6th International Symposium on Highway Capacity and Quality of Service*. TRB, Stockholm, Procedia Social and Behavioral Sciences, Vol. 16, pp 48-56.
- Gipps P.G. (1986) 'A Model for the Structure of Lane changing Decisions', *Transportation Research: B*, 20(5), pp 403-414.
- Gipps, P. G. (1981) 'A behavioural car following model for computer simulation'. *Transportation Research: B*, 15(2), pp 105-111.
- Goodman, P. S. (2001) *The prediction of road traffic noise in urban areas*, PhD thesis, University of Leeds, UK.
- Gordon, R. L. (1996) Algorithm for controlling spillback from ramp meters, *Transportation Research Record*. No. 1554, pp 162 - 171.
- Gould, C., Munro, P. and Hardman E. (2002) 'M3/M27 Ramp Metering Pilot Scheme (RMPS)-implementation and assessment', *IEEE conference on Road Transport Information and Control*, pp 161-167.
- Guan, Y., Zhang, N., Zhu, J. and Yang, X. (2010) 'Modeling on-ramp capacity with driver behavior variation', *Journal of Transportation Systems Engineering and Information Technology*, 10(1), pp 122-127.
- Gunay, B (2004) 'An investigation of lane utilisation on Turkish highways', *Proceeding of the Institute of Civil Engineering (ICE)-Transport*, 157(1), pp 43-49.

- Hadj-Salem, H., and M. Papageorgiou (1995) 'Ramp metering impact on urban corridor traffic: field results', *Transportation Research: A*, 29(4), pp 303-319.
- Hadj-Salem, H., Blossville, J.M. Papageorgiou, M. (1990) 'A local feedback control law for on-ramp metering; a real-life study', *IEEE Road Traffic Control*, pp 194-198.
- Hall, F. L., Allen, B. L. and Gunter, M. A. (1986) 'Empirical analyses of freeway flow-density relationships', *Transportation Research: A*, 20(3), pp 197-210.
- Hasan, M., Jha, M. and Ben-Akiva, M. (2002) 'Evaluation of ramp control using a microscopic simulation', *Transportation Research: C*, 10(3), pp 229-256.
- Hegy, A. De Schutter, B. and Hellendoorn, J. (2005) 'Optimal coordination of variable speed limits to suppress shock waves', *IEEE Transactions on Intelligent Transportation Systems*, 6(1), 102-112.
- Heydecker, B. G. and Addison, J. D. (2008) Measuring traffic flow using real-time data. *TRB Traffic Flow Theory and Characteristics Committee (AHB45) Summer Meeting 2008: The Fundamental Diagram: 75 Years (Greenshields75 Symposium)*. Washington DC: TRB.
- Heydecker, B. G. and Addison, J. D. (2011) 'Analysis and modelling of traffic flow under variable speed limits', *Transportation Research: C*, 19(2), pp 206-217.
- Hayter, A.J. (2002) *Probability and statistics for engineers*, 2<sup>nd</sup> Edition, Duxbury Thomson Learning, USA.
- Heydecker, B. G., Cai, C. and Wong, C. (2007) 'Adaptive dynamic control for road traffic signals', *IEEE International Conference on Networking, Sensing and Control*. London, UK.
- Hidas, P. (1998) 'A car-following model for urban traffic simulation', *Traffic Engineering + Control*, 39(5), pp 300-305.
- Hidas, P. (2005) 'Modelling vehicle interactions in microscopic simulation of merging and weaving', *Transportation Research: C*, 13(1), pp 37-62.
- Highways Agency (2007) *Ramp metering summary report*, UK.
- Highways Agency (2008) *Ramp metering technical design guidelines*, MCH 2470/B, UK.
- Hoffman, E.R. and Mortimer, G.R. (1994) 'Estimate of time to collision', *Accident Analysis and Prevention*, 26(4), pp 511-520.
- Hoffman, E.R. and Mortimer, G.R. (1996) 'Scaling of relative velocity between vehicles', *Accident Analysis and Prevention*, 28(4), pp 415-421.
- Hollis, E. and Evans, R. (1976) *Motorway traffic patterns*, Transport and Road Research Laboratory, TRRL Laboratory Report 705.
- Horowitz, R., May, A., Skabardonis, A., Varaiya, P., Zhang, M., Gomes, G., Muñoz, L., Sun, X. and Sun, D. (2005) *Design, field implementation and evaluation of adaptive ramp metering algorithms*, Research Reports. California Partners for Advanced Transit and Highways (PATH), Institute of Transportation Studies, UC Berkeley.
- Hounsell, N. and McDonald, M. (1992) *An investigation of flow breakdown and merge capacity on motorways*, Contractor Report 338, Transport Research Laboratory, UK.
- Hourdakis, J., Michalopoulos, P. G. And Kottommannil, J. (2003) 'Practical procedure for calibrating microscopic traffic simulation models', *Transportation Research Record*. No. 1852, pp 130-139.
- Huddart, K.W. and Lafont, R. (1990) 'Close driving hazard or necessity?' *Proceedings of the 18th PTRC meeting*, pp 205-217, Seminar G-P334.
- Institute of Transportation Engineering ITE (1999). *Traffic Engineering Handbook*, 5<sup>th</sup> Edition, USA.



- Institute of Transportation Engineering ITE (2010), *Traffic Engineering Handbook*, 6<sup>th</sup> Edition, USA.
- Jin, W. (2010) 'A kinematic wave theory of lane-changing traffic flow'. *Transportation Research: B*, 44(8-9), pp 1001-1021.
- Johansson, G. and Rumer, K. (1971) 'Drivers' brake reaction times', *Human Factors*, 13(1), pp 23-27.
- Kerner, B. S. (2007a) 'On-ramp metering based on three-phase traffic theory-Part I', *Traffic Engineering + Control*, 48(2), pp 28-35.
- Kerner, B. S. (2007b) 'On-ramp metering based on three-phase traffic theory-Part II', *Traffic Engineering + Control*, 48(2), pp 68-75.
- Kerner, B. S. (2007c) 'On-ramp metering based on three-phase traffic theory-Part III', *Traffic Engineering + Control*, 48(2), pp 114-120.
- Kerner, B. S. (2007d) 'Control of spatiotemporal congested traffic patterns at highway bottlenecks', *IEEE Transactions on Intelligent Transportation Systems*, 8(2), pp 314-325.
- Kita, H. (1993) 'Effects of merging lane length on the merging behaviour at expressway on-ramps', *12th Int Symp on the Theory of Traffic Flow and Transportation*.
- Knoop, V. L., Duret, A., Buisson, C. and Arem, B. V. (2010) 'Lane distribution of traffic near merging zones influence of variable speed limits', *Proceeding of the 13th International IEEE Conference on Intelligent Transportation Systems*, pp 485-490.
- Kotsialos, A. and Papageorgiou, M. (2001) 'The importance of traffic flow modelling for motorway traffic control', *Networks and Spatial Economics*, Netherlands, pp 179-203.
- Kotsialos, A. and Papageorgiou, M. (2004) 'Nonlinear optimal control applied to coordinated ramp metering', *IEEE Transactions on control systems technology*, 12(6), pp 920-933.
- Kotsialos, A. and Papageorgiou, M. (2005), 'A hierarchical ramp metering control scheme for freeway networks', *Proceeding of the American Control Conference 4*, pp 2257-262.
- Kou, C. C. and Machemehl, B. (1997a) 'Modelling vehicle acceleration-deceleration behaviour during merge manoeuvres', *Can. J. Civ. Eng.*, 24(3), 3pp 50-358
- Kou, C. C. and Machemehl, B. (1997b) *modelling driver behaviour during merge manoeuvres*, Southwest region university transportation centre report (SWUTC/97/472840-00064-1).
- Laval, J. A. and Leclercq, L. (2008) 'Microscopic modelling of the relaxation phenomenon using a macroscopic lane-changing model', *Transportation Research: B*, 42(6), 511-522.
- Lee, J. and Park, B. (2010) 'Lane flow distributions on basic segments of freeways under different traffic conditions', *TRB 89th Annual Meeting*, pp 10-14, Washington, DC.
- Lerner, N., Huey, R., McGee, H. and Sullivan, A. (1995) *Older driver perception-reaction time for intersection sight distance and object detection*, Report FHWA-RD-93-168, Federal Highway Administration, U.S. Dept. of Transportation, Washington DC.
- Leuthold, R. M. (1975) 'On the use of Theil's inequality coefficients, *American Journal of Agricultural Economics*', Vol. 57, pp 344-346.
- Levinson, D., Zhang, L., Das, S. and Sheikh, A. (2004) *Measuring the equity and efficiency of ramp meters*. Minnesota Department of Transportation, Final report.
- Liu, H. X., Wu, X. Ma, W. and Hu, H. (2009) 'Real-time queue length estimation for congested signalized intersections', *Transportation Research: C*, 17(4), pp 412-427.

- Liu, R. and Hyman, G. (2008) 'Towards a generic guidance for modelling motorway merge', *European Transport Conference ETC*, The Netherlands.
- Liu, R., Vliet, D. V. and Watling, D. P. (1995) 'DRACULA: Dynamic Route Assignment Combining User Learning and microsimulAtion', *Proc. PTRC Annual Conference, Seminar E*, 143-152.
- Lu, X. Qiu, T. Z., Varaiya, P., Horowitz, R., and Shladover, S. E. (2010) 'Combining variable speed limits with RM for freeway traffic control', *American Control Conference*, USA.
- Masher, D.P., Ross, D.W., Wong, P.J., Tuan, P.L., Zeidler, H.M., and Petracek, S., (1975) *Guidelines for design and operation of ramp control systems*, Stanford Research Institute, Menid Park, CA.
- Maxwell, I. and York, I. (2005) 'Review of the red to green sequence at traffic signals', *European Transport Conference*, France.
- Maycock, G, Brocklebank, P. and Hall, R. (1999) 'Road layout design standards and driver behavior', *Proc. Institution of Civil Engineers - Transport*, 135(3), 115-122.
- McDonald, M., Brackstone, M. and Jeffery, D. (1994) 'Data requirements and sources for the calibration of microscopic motorway simulation models', *Proceeding of Vehicle Navigation and Information Systems Conference*, pp 233-238.
- Michaels, R. M. and Fazio, J. (1989) 'Driver behaviour model of merging', *Transportation Research Record*, No. 1213, pp 4-10.
- Michaels, R.M. (1963) 'Perceptual Factors in Car following'. In *Proceeding of the 2nd International Symposium on the Theory of Traffic Flow – OECD*. 44-59, Paris.
- Miller, A. (1972) 'Nine estimators of gap acceptance parameters', *Proceedings of the 5th International Symposium on Transportation and Traffic Theory*, 215-235.
- Minnesota Department of Transportation (2001) *Twin Cities ramp meter evaluation, Executive Summary*, Cambridge Systematics, Inc., Cambridge, Mass.
- Moriyama, Y., Mitsuhashi, M., Hirai, S. and Oguchi, T. (2011) 'The effect of lane utilisation and traffic capacity of adding an auxiliary lane', *TRB Proceedings of the 6th International Symposium on Highway Capacity and Quality of Service*, Stockholm, Sweden, Procedia Social and Behavioral Sciences, Vol. 16, pp 37-47.
- Nagel, K., (1995) *High-speed micro simulations of traffic flow*, PhD Thesis, University of Cologne, Germany.
- Nissan, A. and Koutsopoulos, H. N. (2011) 'Evaluation of the impact of advisory variable speed limits on motorway capacity and level of service', *TRB Proceedings of the 6th International Symposium on Highway Capacity and Quality of Service*, Stockholm, Sweden, Procedia Social and Behavioral Sciences, Vol. 16, pp 100-109.
- Nordaen, T. and Rundmo, T. (2009) 'Perceptions of traffic risk in an industrialised and a developing country', *Transportation Research: F*, 12(1), pp 91-98.
- O'Flaherty, C.A. (1986) *Highways: Traffic planning and Engineering Vol. 1*, 3<sup>rd</sup> Edition, Edward Arnold, London.
- Oh, H. and Sisiopiku, V. P. (2001) 'A modified ALINEA ramp metering model', *80th annual meeting of the Transportation Research Board*, USA.
- Owens, D. and Schofield, M. J. (1990) *Motorway access control: implementation and assessment of Britain's first ramp metering scheme*. Transport Research Laboratory Project Report 252.

- Ozkan, T., Lajunen, T., Chliaoutakis, J., Parker, D. and Summala, H. (2006) 'Cross-cultural differences in driving behaviours: A comparison of six countries', *Transportation Research: F*, 9(3), 227-242.
- Panwai, S. and Dia, H. (2005) 'Comparative evaluation of microscopic car-following behavior', *IEEE Transactions on Intelligent Transportation Systems*, 6(3), pp 314-325.
- Papacostas, C. S. (2005) *Transportation Engineering and Planning*, University of Hawaii at Manoa, Hawaii.
- Papageorgiou M. (1991) *Concise encyclopaedia of traffic & transportation systems*, Pergamon Press, USA.
- Papageorgiou, M and Kotsialos, A. (2002) 'Freeway ramp metering: an overview', *IEEE transactions on intelligent transportation systems*, 3(4), pp 271-281.
- Papageorgiou, M., Hadj-Salem, H. and Blosseville, J.M. (1991) 'ALINEA: a local feedback control law for on-ramp metering', *Transportation Research Record*, No. 1320, pp 58 - 64.
- Papageorgiou, M., Kosmatopoulos, E. and Papamichail, I. (2008) 'Effects of variable speed limits on motorway traffic', *Transportation Research Board*, No. 2047, pp 37-48.
- Papageorgiou, M., Kosmatopoulos, E., Papamichail, I. and Wang, Y. (2008) 'A Misapplication of the Local Ramp Metering Strategy ALINEA', *IEEE Transactions on Intelligent Transportation Systems*, 9(2), pp 360-365.
- Papamichail, I. and Papageorgiou, M. (2008) 'Traffic-responsive linked ramp-metering control', *IEEE Transactions on Intelligent Transportation Systems*, 9(1), pp 111-121.
- Papamichail, I., Kotsialos, A., Margonis, I. and Papageorgiou, M. (2010) 'Coordinated ramp metering for freeway networks—A model-predictive hierarchical control approach', *Transportation Research: C*, 18 (3), pp 311–331.
- Parker, M.T. (1996) The effect of heavy goods vehicles and following behaviour on capacity at motorway roadwork sites, *Traffic Engineering + Control*, 37(9), 524-531.
- Pollatschek, M. A., Polus, A. and Livneh, M. (2002) 'Decision model for gap acceptance and capacity at intersections', *Transportation Research: B*, 36(7), pp 649–663.
- Purnawan, P. (2005) *Developing of traffic micro-simulation for on-Street parking facilities*, PhD thesis, University of Salford, UK.
- Salter, R. J. (1989a) *Traffic engineering worked examples*, 2<sup>nd</sup> Edition, MacMillan Education Ltd, Hong Kong.
- Salter, R. J. (1989b) *Highway traffic analysis and design*, 2<sup>nd</sup> Edition, MacMillan Education Ltd, Hong Kong.
- Salter, R. J. and Hounsell, N. B. (1996) *Highway traffic analysis and design*, 3<sup>rd</sup> Edition, MacMillan Press Ltd, UK.
- Sarintorn, W. (2007) 'Development and comparative evaluation of ramp metering algorithms using microscopic traffic simulation', *Journal of Transportation*, 7(5), pp 51-62.
- Sarvi, M. and Kuwahara M. (2007) 'Microsimulation of freeway ramp merging processes under congested traffic conditions', *IEEE transactions on Intelligent Transportation Systems*, 8(3), pp 470-479.
- Sauer, C. and Andersen, G.J. (2004) *Detection and avoidance of collisions: the react model*, Research reports, Institute of Transportation Studies, California Partners for Advanced Transit and Highways (PATH). University of California, Berkeley.
- Sayer, J.R., Mefford, M.L., and Huang, R. (2003) 'The effect of lead vehicle size on driver following behavior: Is ignorance truly bliss?' *In Proceedings of the 2nd international*

- driving symposium on human factors in driver assessment, training and vehicle design*, University of Iowa.
- Scariza, J. R., (2003) *Evaluation of coordinated and local ramp metering algorithms using Microscopic Traffic Simulation*, MSc Thesis, MIT, US.
- Sisiopiku, V. P., Das, A. and Sullivan, A. (2005) *Applications of freeway ramp metering in alabama*, University Transportation Center for Alabama (UTCA), Report 04203.
- Skabardonis, A. (1981) *A Model of Traffic Flow at Ramp Entries*, PhD.Thesis, University of Southampton.
- Slinn, M., Matthews, P. and Guest, P. (2005) *Traffic engineering design principles and practice*, 2<sup>nd</sup> Edition, Elsevier Ltd.
- Smaragdis, E., and Papageorgiou, M. (2003) 'A series of new local ramp metering strategies, Transportation Research Board', *82nd Annual Meeting*, Washington, DC.
- Smaragdis, E., Papageorgiou, M. and Kosmatopoulos, E. (2004) 'A flow-maximizing adaptive local ramp metering strategy', *Transportation Research: B*, 38(3), pp 251-270.
- Smeed R.J., Bennett G.T. (1949) 'Research on road safety and traffic flow', *Proc Institution of Civil Engineers*, Road Division.
- Smith, S.A.( 1985) *Freeway data collection for studying vehicle interaction*, Technical Report FHWA/RD-85/108, FHWA, US, Department of Transportation.
- Sparmann, U. (1979) 'The Importance of lane changing on motorways', *Traffic Engineering + Control*, 20(6), pp 320-323
- Sultan, B. (2000) *The study of motorway operation using a microscopic simulation model*, PhD thesis, University of Southampton, UK.
- Sultan, B., McDonald M., (2001) 'The lane changing process: Data analysis and modeling behaviour', *Traffic Engineering + Control*, 43(5), 202-207.
- Taale, H. & Middelham. F. (2000) 'Ten years of ramp-metering in the netherlands', *IEEE Proceedings of the 10th International Conference on Road Transport Information and Control*, pp 106-110.
- The European ramp metering project, EURAMP (2007) *Handbook of ramp metering. European Ramp Metering Project*, FP6, Deliverable 7.5.
- TiS (2003) *Information sheet 3.1/TiS 03/03: TCC Traffic Data*, TiS, Quinton Business Park, Birmingham.
- Toledo, T. (2003) *Integrated driving behaviour modelling*, PhD thesis, Massachusetts Institute of Technology, USA.
- Tolle J. E. (1976) 'Vehicular headway distributions: testing and results', *Transportation Research Board*, Vol. 576, pp 56-64.
- Transportation Research Board (2010) *Highway Capacity Manual (HCM)*, Washington, D.C
- Troutbeck, R.J. (2002) 'The performance of uncontrolled merges using a limited priority process', *Proceedings of the 15th International Symposium on Transportation and Traffic Theory*, Pergamon, Amsterdam, pp 463-482.
- Turner, D. J. (1983) 'Traffic characteristics of a rural motorway', *Traffic Engineering + Control*, 24(5), pp 248-251.
- Van As, S. C. (1979) *Traffic Signal Optimisation-Procedures and Techniques*, PhD Thesis, University of Southampton, UK.

- Vanajakshi, L. D. (2004) *Estimation and prediction of travel time from loop detector data for intelligent transportation systems applications*, PhD dissertation, Texas A&M University.
- Walck, C. (1996) *Hand-book on statistical distributions for experimentalists*, Particle Physics Group, University of Stockholm.
- Wall, G. T. and Hounsell, N. B. (2005) 'Microscopic modelling of motorway diverges', *European Journal of Transport and Infrastructure Research*, 5(3), pp 139-158.
- Wang, J. (2006) *A merging model for motorway traffic*, PhD Thesis, University of Leeds, UK.
- Wang, Y. and Papageorgiou, M. (2006) 'Local ramp metering in the case of distant downstream bottlenecks', *IEEE Intelligent Transportation Systems Conference ITSC*, pp 426-431.
- Wang, Y., Papageorgiou, M., Gaffney, J., Papamichail, I. and Guo, J. (2010) 'Local ramp metering in the presence of random-location bottlenecks downstream of a metered on-ramp', *13th International IEEE Annual Conference on Intelligent Transportation Systems*.
- Wasielowski, P. (1981) 'The effect of car size on headways in freely flowing freeway traffic', *Transportation Science*, 15(4), pp 364-378.
- Webster, N. and Elefteriadou, L. (1999) 'A simulation study of truck passenger car equivalents (PCE) on basic freeway sections', *Transportation Research: B*, 33(5), pp 223-336.
- Wiedemann, R. (1974) 'Simulation des Straßenverkehrsflusses', *Vol. Heft 8, Karlsruhe, Germany*, Instituts für Verkehrswesen der Universität Karlsruhe.
- Worrall, R. D. Coutts, D. W., Echterhoff-hammerschmid, H. and Berry, D. S. (1967) 'Merging behaviour at freeway entrance ramps: Some elementary empirical considerations', *Highway Research Record*, No. 157, pp 77-102.
- Wright, P. H. and Ashford, N. J. (1998) *Transportation Engineering*, 4th Edition, John Wiley & Sons, New York, USA.
- Wu, J. and McDonald, M. (1995) 'TRGMSM, a simulation model for signalled intersections with at-grade LRT', *Transportation systems: theory and application of advanced technology*, Vol. 2, pp 695-700
- Wu, J., Brackstone, M. and McDonald, M. (2003) 'The validation of a microscopic simulation model: a methodological case study', *Transportation Research: C*, 11(6), pp 643-479.
- Wu, J., McDonald, M. and Chatterjee, K. (2007) 'A detailed evaluation of ramp metering impacts on driver behaviour', *Transportation Research: F*, 10(1), pp 61-75.
- Wu, N. (2006) 'Equilibrium of lane flow-distribution on motorways', *Transportation Research Board*, No. 1965, pp 48-59.
- Wu, X., Michalopoulos, P. and Liu, H. X. (2010) 'Stochasticity of freeway operational capacity and chance-constrained ramp metering', *Transportation Research: C*, 18(5), pp 741-756.
- Xuwen, C., Dianhai, W. and Sheng, J. (2007) 'On-ramp metering on Beijing urban expressway', *Proceedings of the IEEE International Conference on Automation and Logistics*, Jinan, China.
- Yang Q. and Koutsopoulos H.N. (1996) 'A microscopic traffic simulator for evaluation of dynamic traffic management systems', *Transportation Research: C*, 4(3), pp 113-129.

- Yoo, H., and Green, P. (1999) *Driver behavior while following cars, trucks and buses*. Report No. UMTRI-99-14, The University of Michigan, Transportation Research Institute.
- Yousif, S. (1993) *Effect of Lane Changing on traffic operation for dual carriageway roads with roadworks*, PhD Thesis, University of Wales, Cardiff.
- Yousif, S. and Al-Obaedi, J. (2011) 'Close following behaviour: Testing visual angle car following models using various sets of data'. *Transportation Research: F*, 14(2), pp 96-110.
- Yousif, S. and Hunt, J. (1995) 'Modelling lane utilisation for British dual-carriageway roads: effect of lane changing', *Traffic Engineering + Control*, 36(12), pp 680-687.
- Zhang, L. and Levinson, D. (2010) 'Ramp metering and freeway bottleneck capacity', *Transportation Research: A*, 44(4), pp 218-235.
- Zhang, X. and Bham, G.H. (2007) 'Estimation of driver reaction time from detailed vehicle trajectory data', *Proceeding of the 18th IASTED International Conference*, pp 574-579.
- Zheng, P. (2003) *A microscopic simulation model of merging operation at motorway on-ramps*, PhD Thesis, University of Southampton, UK.
- Zia, F. F. (1992) *Traffic operation at merges on motorways and dual carriageways*, PhD Thesis, University of Wales, Cardiff, UK.

## References from the web

- Federal Highway administration (2009), available from:  
<http://ops.fhwa.dot.gov/trafficanalysisstools/ngsim.htm> [Accessed on September 2009].
- The UK Highway agency (2010), available from:  
<http://www.highways.gov.uk> [Accessed on November 2010].
- The UK Highways Agency (2011), available from:  
[www.standardsforhighways.co.uk/dmrb/vol7](http://www.standardsforhighways.co.uk/dmrb/vol7) [Accessed on January 2011].
- Quadstone Paramics (2011), available from:  
<http://www.paramics-online.com/downloads> [Accessed on December 2011]. Presents Paramics technical report 'Car-following, lane-changing and junction modelling' By Duncan, G.

## **Appendix A : Effect of vehicle type on the following behaviour**

Table A-1 shows an example of the individual vehicles raw data (IVD) for the M42 motorway section before the data was analysed. Table A-2 shows an example for the IVD after being separated per lane using computer program1 as shown in Appendix B.

Table A-3 presents an example of the final output of computer program2 as shown in Appendix B, based on the methodology described in section 4.4. The outputs are sample size, average following distance, time headway and the average speed according to the type of movements (i.e. C-C, C-H, H-C, and H-H).

Table A-4 to Table A-21 show the average following distance (clear spacing) between vehicles based on the M25 and M42 data for different criteria in order to define the maximum speed difference and maximum following headway as described in section 4.3.

Table A-1 Typical example for the IVD data

Vehicle code				Direction Lane			Headway	Speed	Length (cm)
004612	120593	0000	01 00	000000	1 1 1	11.5	111	444	
004613	120593	0000	01 00	000000	2 4 1	39.3	148	538	
004614	120593	0000	01 00	000000	2 3 1	16.5	106	329	
004615	120593	0000	02 00	000000	1 3 1	34.3	115	636	
004616	120593	0000	03 00	000000	1 2 1	26.5	100	912	
004617	120593	0000	06 00	000000	1 1 1	4.5	106	734	
004618	120593	0000	06 00	000000	1 2 1	3.9	110	444	
004619	120593	0000	07 00	000000	2 4 1	99.9	148	270	
004620	120593	0000	07 00	000000	2 3 1	5.2	147	330	
004621	120593	0000	07 00	000000	2 1 1	2.0	85	1593	
004622	120593	0000	09 00	000000	2 3 1	2.0	111	420	
004623	120593	0000	10 00	000000	2 2 1	21.0	117	457	
004624	120593	0000	12 00	000000	2 1 1	25.7	122	462	
004625	120593	0000	13 00	000000	1 2 1	6.5	96	459	
004626	120593	0000	14 00	000000	1 1 1	8.9	123	414	
004627	120593	0000	18 00	000000	1 2 1	5.0	116	432	
004628	120593	0000	18 00	000000	1 1 1	3.6	101	386	
004629	120593	0000	23 00	000000	2 3 1	13.9	124	368	
004630	120593	0000	25 00	000000	2 3 1	1.7	138	459	
004631	120593	0000	26 00	000000	2 4 1	19.1	171	278	
004632	120593	0000	27 00	000000	2 1 1	14.8	88	1764	
004633	120593	0000	29 00	000000	1 1 1	11.3	111	399	
004634	120593	0000	34 00	000000	1 2 1	15.9	110	400	
004635	120593	0000	44 00	000000	2 2 1	37.3	130	403	
004636	120593	0000	49 00	000000	1 1 1	19.0	86	1677	
004637	120593	0000	49 00	000000	1 2 1	15.3	137	409	
004638	120593	0000	51 00	000000	1 2 1	1.6	137	383	
004639	120593	0000	54 00	000000	1 2 1	3.2	110	379	
004640	120593	0000	55 00	000000	2 1 1	28.8	111	447	
004641	120593	0000	55 00	000000	1 1 1	7.0	93	378	
004642	120593	0000	56 00	000000	2 3 1	1.4	148	506	
004643	120593	0000	56 00	000000	1 3 1	54.1	104	474	
004644	120593	0000	58 00	000000	1 2 1	3.8	88	404	
004645	120593	0000	59 00	000000	2 1 1	3.7	101	712	
004646	120593	0001	00 00	000000	1 3 1	3.5	116	407	
004647	120593	0001	05 00	000000	2 2 1	20.7	106	438	
004648	120593	0001	08 00	000000	2 1 1	7.9	85	1628	
004649	120593	0001	08 00	000000	2 3 1	41.9	124	392	
004650	120593	0001	09 00	000000	1 3 1	9.0	146	481	
004651	120593	0001	10 00	000000	1 1 1	13.4	79	1773	
004652	120593	0001	10 00	000000	1 2 1	11.2	88	1456	



Table A-2 Example for the separated IVD per lane

Lane	Speed	Headway	Length	Lane	Speed	Headway	Length	Lane	Speed	Headway	Length
1	111	11.5	444	2	100	26.5	912	3	115	34.3	636
1	106	4.5	734	2	110	3.9	444	3	104	54.1	474
1	123	8.9	414	2	96	6.5	459	3	116	3.5	407
1	101	3.6	386	2	116	5.1	432	3	146	9.0	481
1	111	11.3	399	2	110	15.9	400	3	96	5.7	440
1	86	19.0	1677	2	137	15.3	409	3	100	17.9	445
1	93	7.0	378	2	137	1.6	383	3	104	14.2	367
1	79	13.4	1773	2	110	3.2	379	3	136	2.0	434
1	89	5.7	1726	2	88	3.8	404	3	100	20.8	386
1	86	1.8	1621	2	88	11.2	1456	3	129	7.4	451
1	86	4.5	1435	2	101	9.5	411	3	82	4.1	463
1	82	5.6	1623	2	95	1.5	416	3	92	29.4	451
1	93	15.8	1717	2	110	5.0	376	3	115	3.1	427

Table A-3 Example for the final output

Lane 1				Lane 2					
Type	Sample	Spacing	Headway	Speed	Type	Sample	Spacing	Headway	Speed
C-C	211	6.51	2.42	16.09	C-C	310	6.59	2.45	15.97
C-H	78	5.64	4.50	15.50	C-H	101	6.08	4.31	16.01
H-C	74	6.77	2.43	16.26	H-C	66	6.79	2.46	16.27
H-H	39	5.73	4.59	15.62	H-H	33	6.32	4.06	16.45
C-C	297	9.39	1.92	25.58	C-C	589	9.76	1.95	25.77
C-H	141	9.82	3.34	25.42	C-H	161	9.78	3.17	25.68
H-C	98	9.74	1.95	25.95	H-C	138	9.52	1.94	25.41
H-H	66	9.11	3.28	25.53	H-H	67	10.44	3.35	25.85
C-C	439	12.54	1.70	35.54	C-C	1024	12.53	1.67	35.85
C-H	210	12.60	2.64	35.84	C-H	327	12.76	2.55	36.20
H-C	148	12.34	1.65	36.00	H-C	254	12.45	1.65	36.15
H-H	92	13.80	2.79	35.96	H-H	136	13.28	2.64	36.11
C-C	793	15.23	1.52	45.95	C-C	1904	15.35	1.53	45.99
C-H	389	15.02	2.22	45.69	C-H	563	15.50	2.22	45.86
H-C	235	15.39	1.53	45.89	H-C	337	15.52	1.55	45.69
H-H	156	16.10	2.33	46.02	H-H	203	16.06	2.31	45.65
C-C	1744	17.86	1.42	55.85	C-C	2860	17.99	1.43	55.79
C-H	664	17.88	2.03	55.85	C-H	872	18.25	2.01	56.02
H-C	455	17.77	1.42	55.71	H-C	620	18.60	1.46	55.89
H-H	300	18.86	2.09	55.95	H-H	273	19.87	2.12	56.17
C-C	1777	20.97	1.38	65.80	C-C	3228	20.61	1.35	65.78
C-H	824	20.60	1.85	66.21	C-H	1010	20.57	1.82	65.97
H-C	550	21.09	1.37	66.32	H-C	704	20.98	1.37	65.86
H-H	480	21.60	1.91	66.38	H-H	415	20.88	1.86	65.96
C-C	2621	23.74	1.32	75.96	C-C	5282	22.22	1.25	76.00
C-H	1860	23.87	1.75	76.29	C-H	2129	22.82	1.68	76.04
H-C	945	23.33	1.30	76.10	H-C	1398	22.49	1.26	75.87
H-H	1367	24.43	1.78	76.78	H-H	921	23.14	1.72	76.09
C-C	2830	27.29	1.31	86.05	C-C	11179	24.66	1.20	86.12
C-H	4074	28.14	1.77	86.46	C-H	6782	24.85	1.59	86.61
H-C	1499	28.36	1.36	86.20	H-C	2950	25.91	1.25	86.28
H-H	10496	28.87	1.81	87.07	H-H	5278	25.32	1.64	86.80
C-C	1430	31.52	1.36	94.28	C-C	12116	28.74	1.25	94.65
C-H	928	32.69	1.79	93.53	C-H	3453	28.65	1.58	93.74
H-C	428	33.31	1.44	93.68	H-C	1780	29.42	1.28	94.11
H-H	2033	31.56	1.80	92.97	H-H	1775	28.28	1.61	93.16

Table A-4 Average following distance (m) for test No.1 and for the M25

Lane No.	Case	Speed class (km/hr)										
		10-20	20-30	30-40	40-50	50-60	60-70	70-80	80-90	90-100	100-110	110-120
1	C-C	6.5	9.4	12.5	15.2	17.9	21.0	23.7	27.3	31.5	35.5	40.9
	C-H	5.6	9.8	12.6	15.0	17.9	20.6	23.9	28.1	32.7	36.3	43.0
	H-C	6.8	9.7	12.3	15.4	17.8	21.1	23.3	28.4	33.3	37.2	41.7
	H-H	5.7	9.1	13.8	16.1	18.9	21.6	24.4	28.9	31.6	33.1	33.4
2	C-C	6.6	9.8	12.5	15.4	18.0	20.6	22.2	24.7	28.7	33.1	37.8
	C-H	6.1	9.8	12.8	15.5	18.2	20.6	22.8	24.8	28.7	32.6	37.9
	H-C	6.8	9.5	12.4	15.5	18.6	21.0	22.5	25.9	29.4	33.0	36.4
	H-H	6.3	10.4	13.3	16.1	19.9	20.9	23.1	25.3	28.3	31.9	35.6
3	C-C	6.6	9.8	12.8	15.5	18.2	20.8	22.6	24.4	27.7	31.2	35.1
	C-H	6.2	9.7	12.6	16.0	17.7	19.9	22.6	23.7	26.0	30.0	34.9
	H-C	6.0	9.2	11.7	14.6	16.6	19.9	21.2	23.1	26.2	29.6	32.8
	H-H	7.2	10.1	13.4	15.5	19.3	19.3	22.3	23.0	26.3	28.0	33.4

Table A-5 Average following distance (m) for test No.1 and for the M42

Lane No.	Case	Speed class (km/hr)										
		10-20	20-30	30-40	40-50	50-60	60-70	70-80	80-90	90-100	100-110	110-120
1	C-C	6.4	9.7	12.9	15.8	18.1	19.8	22.7	27.0	32.3	37.9	41.7
	C-H	6.4	9.5	12.9	15.3	17.9	20.6	23.9	28.4	32.1	38.7	39.0
	H-C	7.3	10.0	12.8	15.7	18.7	20.7	23.5	28.8	33.6	37.7	41.1
	H-H	6.7	10.4	13.8	16.4	19.2	22.5	24.8	28.5	30.8	36.0	39.1
2	C-C	6.8	9.7	12.9	15.5	18.3	20.5	22.2	23.9	28.4	33.7	37.8
	C-H	6.2	9.3	12.9	15.8	19.1	20.4	23.2	24.5	26.7	33.1	38.0
	H-C	6.5	8.9	11.9	14.6	17.1	19.0	20.8	22.8	27.0	32.6	36.9
	H-H	7.3	8.4	12.1	16.5	18.3	20.3	20.4	21.2	23.9	31.8	36.5

Table A-6 Average following distance (m) for test No.2 and for the M25

Lane No.	Case	Speed class (km/hr)										
		10-20	20-30	30-40	40-50	50-60	60-70	70-80	80-90	90-100	100-110	110-120
1	C-C	8.4	11.7	15.3	18.4	21.1	24.8	28.5	34.1	40.9	47.0	56.8
	C-H	8.1	11.9	14.8	17.7	20.4	24.5	28.2	35.3	42.7	48.7	56.5
	H-C	8.6	12.5	15.5	19.5	22.6	26.4	30.4	39.5	46.4	52.0	60.3
	H-H	7.9	12.6	17.6	20.5	23.0	27.8	31.0	39.2	43.0	45.9	49.2
2	C-C	8.4	11.9	15.0	18.3	21.2	24.2	25.9	28.9	35.1	41.8	49.4
	C-H	8.0	12.5	14.9	17.7	21.2	23.9	26.5	29.0	35.1	41.7	51.6
	H-C	9.1	12.5	15.5	20.0	23.3	26.2	27.8	34.2	39.3	44.6	48.4
	H-H	8.4	12.6	16.5	20.5	23.9	25.8	28.6	32.4	37.0	42.1	45.3
3	C-C	8.6	12.0	15.1	18.0	21.2	23.9	25.8	27.8	32.0	36.9	42.7
	C-H	8.2	12.0	15.2	18.4	20.6	23.2	26.0	26.9	30.3	35.9	42.9
	H-C	7.9	11.3	14.9	17.8	19.8	23.6	25.1	28.0	31.7	36.7	41.6
	H-H	7.2	11.9	16.5	19.1	23.2	24.0	25.4	27.3	31.7	33.2	43.0

Table A-7 Average following distance (m) for test No.2 and for the M42

Lane No.	Case	Speed class (km/hr)										
		10-20	20-30	30-40	40-50	50-60	60-70	70-80	80-90	90-100	100-110	110-120
1	C-C	8.3	11.9	16.1	19.1	21.5	23.5	26.7	32.6	41.5	50.2	56.3
	C-H	8.5	11.7	15.8	18.2	22.2	23.7	28.4	35.3	41.5	51.7	52.9
	H-C	9.2	12.4	16.8	19.9	24.2	26.8	29.5	39.7	46.5	52.2	55.8
	H-H	8.9	13.3	17.7	21.0	24.5	27.1	30.6	38.1	41.5	46.5	46.5
2	C-C	8.5	11.6	15.5	18.1	21.5	23.6	25.4	27.1	33.6	41.9	48.5
	C-H	8.1	12.0	14.4	18.8	22.1	24.1	26.5	27.7	31.3	40.6	48.6
	H-C	8.3	11.4	15.4	18.0	20.1	23.5	24.3	28.9	34.7	42.5	47.4
	H-H	9.9	10.7	14.5	20.4	23.0	23.2	23.3	26.5	29.4	37.6	40.2

Table A-8 Average following distance (m) for test No.3 and for the M25

Lane No.	Case	Speed class (km/hr)										
		10-20	20-30	30-40	40-50	50-60	60-70	70-80	80-90	90-100	100-110	110-120
1	C-C	9.4	12.8	16.4	19.9	22.9	27.1	31.6	38.9	48.9	57.9	69.3
	C-H	8.9	12.9	15.4	18.5	22.5	26.0	31.0	41.0	50.9	60.2	72.9
	H-C	9.8	14.2	18.3	23.7	25.7	30.2	36.1	49.7	58.6	66.0	73.0
	H-H	9.5	14.5	19.9	23.0	25.6	31.4	35.9	48.5	53.4	58.8	63.9
2	C-C	9.3	12.9	16.1	19.7	22.9	26.0	28.0	31.4	39.9	48.7	59.0
	C-H	9.2	13.7	16.1	18.9	22.6	25.7	28.2	31.3	39.7	49.0	61.1
	H-C	11.0	14.3	17.6	22.6	26.2	29.9	31.6	40.9	47.5	53.7	59.5
	H-H	9.9	14.3	18.1	23.2	27.2	29.3	31.9	38.4	44.2	50.2	56.1
3	C-C	9.6	12.9	16.0	19.0	22.4	25.1	27.3	29.4	34.6	40.6	48.2
	C-H	9.6	13.0	15.6	19.3	21.8	24.5	27.6	28.8	32.9	39.7	48.8
	H-C	8.7	12.0	16.0	19.6	22.6	25.6	27.1	32.3	35.5	41.1	47.9
	H-H	10.9	13.1	17.5	21.4	24.5	27.8	26.8	30.8	34.5	36.9	49.1

Table A-9 Average following distance (m) for test No.3 and for the M42

Lane No.	Case	Speed class (km/hr)										
		10-20	20-30	30-40	40-50	50-60	60-70	70-80	80-90	90-100	100-110	110-120
1	C-C	9.4	13.0	17.4	20.5	23.6	25.0	28.7	36.4	49.1	62.0	69.4
	C-H	9.9	12.6	17.2	19.9	23.8	25.9	31.4	40.0	48.8	62.4	66.9
	H-C	11.1	14.0	19.0	22.8	28.1	30.4	34.2	48.9	58.5	65.2	69.3
	H-H	10.5	14.8	19.6	23.5	27.8	30.8	35.8	46.7	50.8	57.2	56.0
2	C-C	9.5	12.5	16.5	19.2	22.9	24.9	26.9	28.7	36.9	47.7	56.6
	C-H	8.7	12.9	16.3	20.5	23.3	25.4	27.6	29.2	34.3	47.4	58.3
	H-C	9.4	12.5	17.3	20.1	22.3	25.1	26.7	34.3	40.6	49.7	56.2
	H-H	11.4	12.9	17.8	22.5	24.7	23.8	26.1	30.5	34.1	43.4	40.2

Table A-10 Average following distance (m) for test No.4 and for the M25

Lane No.	Case	Speed class (km/hr)										
		10-20	20-30	30-40	40-50	50-60	60-70	70-80	80-90	90-100	100-110	110-120
1	C-C	9.9	13.5	17.1	20.8	23.8	28.4	33.5	43.1	55.7	68.6	81.9
	C-H	9.4	13.5	16.1	19.2	23.8	27.8	33.2	45.6	58.2	69.0	81.8
	H-C	10.7	15.4	19.8	25.5	28.9	32.9	40.5	59.7	69.0	78.6	85.2
	H-H	10.8	15.4	21.5	24.3	27.9	34.8	39.5	57.1	63.5	69.5	69.7
2	C-C	9.8	13.3	16.5	20.4	23.6	26.9	29.1	32.9	43.3	54.3	67.3
	C-H	9.8	13.9	16.9	19.2	23.2	26.6	29.5	33.0	43.3	56.1	68.1
	H-C	11.8	15.6	19.1	24.4	28.2	32.5	34.4	46.3	54.9	61.2	70.7
	H-H	10.4	15.1	18.9	24.2	29.1	31.0	34.0	43.3	49.8	57.1	65.1
3	C-C	10.1	13.3	16.5	19.4	22.9	25.6	28.1	30.3	36.1	42.9	52.0
	C-H	9.7	13.4	16.2	20.2	22.1	25.2	28.5	29.7	35.0	42.4	53.3
	H-C	9.8	12.4	16.6	20.2	24.0	26.5	28.5	34.5	37.8	44.5	52.6
	H-H	12.8	14.1	18.6	21.8	25.5	28.5	27.8	32.3	36.3	39.8	50.2

Table A-11 Average following distance (m) for test No.4 and for the M42

Lane No.	Case	Speed class (km/hr)										
		10-20	20-30	30-40	40-50	50-60	60-70	70-80	80-90	90-100	100-110	110-120
1	C-C	9.8	13.7	18.2	21.4	24.3	25.9	30.1	39.3	55.7	71.9	81.7
	C-H	11.0	13.6	17.6	20.8	24.7	26.9	33.2	43.6	55.1	73.7	78.4
	H-C	11.9	15.4	20.5	25.0	29.8	33.2	37.4	56.9	68.1	75.7	83.4
	H-H	11.2	15.9	20.7	24.9	30.1	32.6	38.9	54.1	59.2	65.8	69.7
2	C-C	9.9	13.0	16.9	19.7	23.5	25.7	27.5	29.7	39.1	51.9	62.6
	C-H	9.9	13.3	16.4	20.6	24.0	25.9	28.3	30.4	36.4	51.5	63.3
	H-C	10.4	12.8	17.8	21.0	22.7	26.2	27.4	37.2	44.7	53.8	63.0
	H-H	12.5	14.0	17.2	22.3	24.2	24.2	26.9	33.9	37.7	50.8	47.0

Table A-12 Average following distance (m) for test No.5 and for the M25

Lane No.	Case	Speed class (km/hr)										
		10-20	20-30	30-40	40-50	50-60	60-70	70-80	80-90	90-100	100-110	110-120
1	C-C	6.5	9.4	12.5	15.3	18.0	21.1	24.0	27.6	32.1	36.3	41.3
	C-H	5.5	9.8	12.5	15.0	17.9	20.8	24.1	28.4	33.6	37.6	42.3
	H-C	6.7	9.8	12.4	15.6	18.0	21.6	23.9	29.2	33.7	37.5	43.1
	H-H	5.7	9.2	13.8	16.1	19.0	21.8	25.4	29.1	32.3	34.5	33.0
2	C-C	6.6	9.8	12.6	15.3	18.1	20.7	22.6	25.1	29.1	33.7	38.5
	C-H	6.0	9.5	12.7	15.5	18.4	20.8	22.8	25.0	29.6	33.7	38.5
	H-C	6.6	9.5	12.5	15.7	18.9	21.2	23.1	26.5	29.9	33.5	37.3
	H-H	6.3	10.0	13.3	16.3	20.1	21.0	23.5	25.5	29.0	32.0	37.0
3	C-C	6.7	9.9	12.9	15.6	18.3	21.0	22.8	24.8	27.9	31.6	35.8
	C-H	5.9	9.7	12.6	15.8	17.8	20.2	23.0	24.0	26.4	30.8	35.6
	H-C	6.1	9.1	11.9	14.7	17.2	20.1	21.4	24.2	26.8	30.3	33.8
	H-H	6.9	10.1	13.4	15.7	19.5	20.0	22.3	23.5	26.3	29.5	33.8

Table A-13 Average following distance (m) for test No.5 and for the M42

Lane No.	Case	Speed class (km/hr)										
		10-20	20-30	30-40	40-50	50-60	60-70	70-80	80-90	90-100	100-110	110-120
1	C-C	6.3	9.7	12.8	15.9	18.3	20.1	23.2	27.4	32.8	38.5	42.1
	C-H	6.0	9.5	13.0	15.3	18.1	20.6	24.5	28.7	33.1	39.4	43.0
	H-C	7.3	10.0	12.8	15.9	18.9	21.4	24.3	29.4	34.1	38.2	41.8
	H-H	6.7	10.1	13.8	16.5	19.4	22.6	25.8	28.7	31.6	36.9	37.5
2	C-C	6.7	9.7	12.9	15.7	18.4	20.8	22.4	24.2	28.8	34.2	38.4
	C-H	5.9	8.8	12.9	15.8	19.2	20.6	23.1	24.5	27.6	34.1	39.0
	H-C	6.4	9.0	12.1	14.7	17.5	19.4	21.0	23.8	27.9	33.4	37.8
	H-H	6.6	8.5	12.4	16.6	18.1	20.3	20.4	21.7	24.8	32.9	35.5

Table A-14 Average following distance (m) for test No.6 and for the M25

Lane No.	Case	Speed class (km/hr)										
		10-20	20-30	30-40	40-50	50-60	60-70	70-80	80-90	90-100	100-110	110-120
1	C-C	8.4	11.8	15.3	18.6	21.4	25.3	29.2	35.1	42.1	48.8	56.4
	C-H	7.9	12.1	15.0	17.8	20.6	24.7	29.2	35.8	45.0	51.8	57.2
	H-C	8.6	12.5	16.0	19.9	23.4	27.2	31.6	40.7	47.2	52.1	61.3
	H-H	7.8	12.6	17.7	20.4	23.2	28.4	32.9	39.5	44.2	49.1	50.0
2	C-C	8.4	11.9	15.2	18.4	21.6	24.7	26.5	29.8	36.0	42.9	50.5
	C-H	8.0	12.4	15.0	18.0	21.4	24.3	26.7	29.5	36.6	43.9	52.5
	H-C	9.0	12.6	15.9	20.3	23.7	27.2	29.0	35.5	40.5	45.6	50.3
	H-H	8.4	12.5	16.6	20.7	24.4	26.5	29.4	33.2	38.0	43.5	45.0
3	C-C	8.6	12.0	15.3	18.2	21.5	24.4	26.3	28.5	32.7	37.9	44.0
	C-H	8.0	12.1	15.2	18.4	20.9	23.6	26.5	27.4	31.3	37.3	44.5
	H-C	7.9	11.2	15.1	18.1	20.7	24.0	26.0	29.5	32.9	37.8	43.8
	H-H	6.9	11.7	16.2	19.2	24.2	24.6	25.9	28.5	32.7	35.3	43.8

Table A-15 Average following distance (m) for test No.6 and for the M42

Lane No.	Case	Speed class (km/hr)										
		10-20	20-30	30-40	40-50	50-60	60-70	70-80	80-90	90-100	100-110	110-120
1	C-C	8.3	11.9	16.2	19.4	22.0	24.0	27.6	33.5	42.6	51.4	56.8
	C-H	8.4	11.9	15.8	18.3	22.4	24.2	29.8	35.8	43.3	53.7	55.5
	H-C	9.2	12.5	16.9	20.4	24.8	27.4	30.8	40.6	47.0	53.6	56.8
	H-H	8.9	13.1	17.7	21.0	24.6	27.4	33.3	38.5	42.8	48.7	49.3
2	C-C	8.5	11.6	15.6	18.4	21.9	24.3	25.7	27.8	34.5	42.8	49.5
	C-H	7.8	11.6	14.5	18.9	22.4	24.5	27.2	27.8	33.1	42.6	51.1
	H-C	8.5	11.3	15.7	18.6	21.3	24.8	24.9	30.8	36.1	43.1	48.6
	H-H	9.3	11.7	15.3	20.3	22.4	23.4	24.1	27.5	31.4	40.7	42.6

Table A-16 Average following distance (m) for test No.7 and for the M25

Lane No.	Case	Speed class (km/hr)										
		10-20	20-30	30-40	40-50	50-60	60-70	70-80	80-90	90-100	100-110	110-120
1	C-C	9.5	12.9	16.5	20.3	23.4	28.1	33.1	40.8	51.0	60.4	69.3
	C-H	8.9	13.1	16.1	18.7	22.8	26.8	32.6	41.9	54.7	63.3	72.6
	H-C	10.0	14.5	19.0	24.2	27.3	31.6	38.1	51.4	59.7	65.7	75.0
	H-H	9.5	14.6	20.1	23.3	26.4	32.3	39.8	49.1	55.3	62.3	66.7
2	C-C	9.4	13.1	16.4	19.9	23.4	26.7	28.9	32.8	41.3	50.4	60.6
	C-H	9.5	13.8	16.3	19.3	23.0	26.3	29.0	32.2	42.0	51.8	62.9
	H-C	10.9	14.5	18.4	23.0	27.0	30.9	33.5	42.9	49.0	55.4	63.2
	H-H	9.8	14.1	18.3	23.5	27.9	30.4	33.4	39.5	45.7	52.5	58.1
3	C-C	9.6	13.0	16.3	19.5	22.9	25.8	28.1	30.4	35.6	41.9	50.0
	C-H	9.5	13.1	15.6	19.5	22.1	24.9	28.4	29.5	34.1	41.5	51.3
	H-C	8.8	12.1	16.4	20.0	23.8	26.3	28.2	34.4	37.4	42.6	50.4
	H-H	10.5	13.2	17.4	21.8	25.6	28.0	28.0	32.2	35.9	38.9	51.1

Table A-17 Average following distance (m) for test No.7 and for the M42

Lane No.	Case	Speed class (km/hr)										
		10-20	20-30	30-40	40-50	50-60	60-70	70-80	80-90	90-100	100-110	110-120
1	C-C	9.4	13.1	17.6	20.9	24.3	25.8	30.0	37.7	50.6	63.6	70.2
	C-H	9.7	12.8	17.2	20.2	24.3	26.9	33.9	40.9	51.4	65.5	71.9
	H-C	11.1	14.3	19.7	23.5	28.9	31.6	36.6	50.2	58.8	66.5	70.8
	H-H	10.5	15.0	19.5	23.8	28.3	31.2	39.9	47.3	52.6	61.3	58.0
2	C-C	9.5	12.7	16.6	19.7	23.3	25.9	27.4	29.6	38.2	49.0	57.9
	C-H	8.4	12.7	16.4	20.7	24.1	26.1	28.7	29.6	36.5	50.0	59.6
	H-C	9.5	12.4	17.5	20.9	23.3	26.9	27.5	36.6	42.8	50.4	56.7
	H-H	10.8	13.1	17.5	23.1	24.1	24.3	26.6	31.9	36.4	47.3	45.9



Table A-18 Average following distance (m) for test No.8 and for the M25

Lane No.	Case	Speed class (km/hr)										
		10-20	20-30	30-40	40-50	50-60	60-70	70-80	80-90	90-100	100-110	110-120
1	C-C	10.1	13.8	17.4	21.4	24.4	29.8	35.4	45.7	58.7	70.9	82.4
	C-H	9.7	13.7	16.8	19.5	24.1	28.7	35.8	47.0	62.9	74.3	82.5
	H-C	10.9	15.8	20.9	26.4	30.4	34.3	43.0	61.5	70.9	79.1	85.8
	H-H	10.9	15.5	21.9	25.0	29.1	36.2	45.1	58.0	65.8	74.8	73.2
2	C-C	10.0	13.6	16.8	20.8	24.3	27.7	30.2	34.7	45.3	56.5	69.2
	C-H	10.3	14.2	17.3	19.6	23.8	27.5	30.7	34.1	46.1	59.6	71.8
	H-C	11.8	16.0	19.9	25.1	29.0	33.9	37.0	49.0	56.6	64.5	74.9
	H-H	10.5	14.9	19.2	24.6	29.9	32.6	36.0	44.8	51.4	59.7	67.6
3	C-C	10.3	13.5	16.9	19.9	23.5	26.5	28.9	31.5	37.3	44.5	54.5
	C-H	9.7	13.6	16.2	20.5	22.4	25.7	29.3	30.5	36.6	44.7	55.7
	H-C	10.0	12.7	17.0	20.6	25.3	27.6	30.0	37.2	40.0	46.1	55.6
	H-H	12.2	14.1	18.3	22.2	26.6	28.7	30.1	33.6	37.8	42.7	52.5

Table A-19 Average following distance (m) for test No.8 and for the M42

Lane No.	Case	Speed class (km/hr)										
		10-20	20-30	30-40	40-50	50-60	60-70	70-80	80-90	90-100	100-110	110-120
1	C-C	9.8	13.9	18.4	22.2	25.2	26.7	31.7	41.1	57.6	73.8	82.8
	C-H	11.0	13.8	18.0	21.2	25.3	28.0	36.6	44.8	58.3	77.4	86.3
	H-C	12.0	15.9	21.7	25.9	30.8	35.0	41.2	58.7	69.1	77.6	85.5
	H-H	11.5	16.2	21.3	25.7	31.1	33.8	45.2	55.0	61.1	71.7	70.3
2	C-C	10.0	13.2	17.1	20.3	24.1	26.7	28.1	30.7	40.7	53.6	64.2
	C-H	10.0	13.2	16.4	21.1	24.8	26.6	29.3	30.8	38.8	54.9	65.2
	H-C	10.4	12.8	18.3	21.8	23.8	28.3	28.6	40.7	47.8	55.6	64.5
	H-H	11.9	14.1	17.5	23.8	24.1	24.9	27.3	35.5	40.3	53.8	48.9

Table A-20 Average following distance (m) for test No.9 and for the M25

Lane No.	Case	Speed class (km/hr)										
		10-20	20-30	30-40	40-50	50-60	60-70	70-80	80-90	90-100	100-110	110-120
1	C-C	6.4	9.5	12.5	15.3	17.9	20.7	23.5	27.2	31.4	35.7	40.5
	C-H	5.9	9.4	12.5	15.0	17.6	20.5	23.6	27.9	32.5	35.6	40.7
	H-C	6.6	9.3	12.4	15.6	17.8	20.8	23.7	28.8	33.0	36.6	43.0
	H-H	5.7	9.1	13.8	16.1	18.9	21.6	24.4	28.9	31.6	33.1	33.4
2	C-C	6.5	9.6	12.6	15.5	18.0	20.6	22.4	24.7	28.4	32.7	37.8
	C-H	5.8	9.8	12.6	15.5	18.3	20.8	22.7	24.6	28.4	32.3	37.6
	H-C	6.5	9.6	12.5	15.4	18.4	21.0	22.5	26.0	28.9	32.6	37.6
	H-H	6.3	10.4	13.3	16.1	19.9	20.9	23.1	25.3	28.3	31.9	35.6
3	C-C	6.5	9.7	12.7	15.6	18.2	20.7	22.7	24.5	27.4	31.1	35.0
	C-H	5.9	9.6	12.6	15.7	17.7	20.3	22.8	23.7	26.1	30.0	34.8
	H-C	5.9	9.2	11.5	14.3	16.9	19.6	21.2	23.7	25.9	29.6	33.0
	H-H	7.2	10.1	13.4	15.5	19.3	19.3	22.3	23.0	26.3	28.0	33.4

Table A-21 Average following distance (m) for test No.9 and for the M42

Lane No.	Case	Speed class (km/hr)										
		10-20	20-30	30-40	40-50	50-60	60-70	70-80	80-90	90-100	100-110	110-120
1	C-C	6.4	9.7	13.0	15.7	18.3	19.8	22.9	27.1	32.2	37.7	41.8
	C-H	6.3	9.3	13.1	15.5	18.0	20.8	23.9	28.3	31.9	38.2	39.3
	H-C	7.4	10.0	13.0	16.2	18.6	20.8	23.8	28.8	33.6	37.5	41.5
	H-H	6.7	10.4	13.8	16.4	19.2	22.5	24.8	28.5	30.8	36.0	39.1
2	C-C	6.7	9.6	12.7	15.5	18.2	20.4	22.3	23.7	27.9	33.1	37.4
	C-H	6.3	9.1	12.8	15.8	19.2	20.5	22.8	24.1	26.2	32.7	37.6
	H-C	6.6	8.9	12.1	14.5	17.2	19.3	20.9	22.9	26.9	32.2	36.5
	H-H	7.3	8.4	12.1	16.5	18.3	20.3	20.4	21.2	23.9	31.8	36.5

## Appendix B : Computer programs used in analysing the individual vehicles' data (IVD)

### Program 1: Filtering the data per lane and estimating flow rates

```

REAL HEADWAY(280000),SUMSPD(4000,4),AVSPD2(4000,4)
REAL AVSPD(4000,4), SUMSPD2(4000,4)
INTEGER C,TIME1(280000), LANE(280000), FLOW(4000,4)
INTEGER SPEED(280000),SITE(280000),T.LENGTH(280000)
INTEGER FLOW2(0:4000,4),hgv11(0:4000,4),hgv12(0:4000,4)
integer hgv21(0:4000,4),hgv22(0:4000,4)
mintime=0      ! Starting time for the data analysis
maxtime=2400 ! Ending time for the data analysis

open(21,file='ALL.input')
open(22,file='check input.DAT')
open(25,file='SITE1.DAT')
open(26,file='LANE1 SITE1.DAT')
open(27,file='LANE2 SITE1.DAT')
open(28,file='LANE3 SITE1.DAT')
open(29,file='LANE4 SITE1.DAT')
open(30,file='SITE2.DAT')
open(31,file='LANE1 SITE2.DAT')
open(32,file='LANE2 SITE2.DAT')
open(33,file='LANE3 SITE2.DAT')
open(34,file='LANE4 SITE2.DAT')
open(45,file='fLOW SITE1.DAT')
open(46,file='fLOW SITE2.DAT')
SUMSPD=0;SUMSPD2=0
FLOW=0;FLOW2=0
DO C= 1,280000
  READ (21,'(I7,I7,I5,I3,I3,I7.3I2,F5.2,I4,i7)')KK1,KK2,TIME1(C),KK3
&.KK4,KK5,SITE(C),LANE(C),KK6,HEADWAY(C),SPEED(C),LENGTH(C)
  WRITE (22,'(I7,I7,I5,I3,I3,I7.3I3,F9.2,I4,i7)')KK1,KK2,TIME1(C),KK3
&.&.KK4,KK5,SITE(C),LANE(C),KK6,HEADWAY(C),SPEED(C),LENGTH(C)

  if (time1(c)>=maxtime) then
  if (time1(c)<=0) then
  max=c-1
  goto 10
  end if; end if

5  IF (SITE(C).EQ.1) THEN
  WRITE(25,*) C,TIME1(C),LANE(C),SPEED(C),HEADWAY(C)
&,&.length(c)
  IF (LANE(C).EQ.1)WRITE(26,*)C,TIME1(C),LANE(C),SPEED(C),HEADWAY(C)
& &.LENGTH(C)
  IF (LANE(C).EQ.2)WRITE(27,*)C,TIME1(C),LANE(C),SPEED(C),HEADWAY(C)
& &.LENGTH(C)

  IF (LANE(C).EQ.3)WRITE(28,*)C,TIME1(C),LANE(C),SPEED(C),HEADWAY(C)
& &.LENGTH(C)
  IF (LANE(C).EQ.4)WRITE(29,*)C,TIME1(C),LANE(C),SPEED(C),HEADWAY(C)
& &.LENGTH(C)
  ELSE
  WRITE(30,*)C,TIME1(C),LANE(C),SPEED(C),HEADWAY(C),length(c)

```

```

      IF (LANE(C).EQ.1)WRITE(31,*)C,TIME1(C),LANE(C),SPEED(C),HEADWAY(C)
& ,LENGTH(C)
      IF (LANE(C).EQ.2)WRITE(32,*)C,TIME1(C),LANE(C),SPEED(C),HEADWAY(C)
& ,LENGTH(C)
      IF (LANE(C).EQ.3)WRITE(33,*)C,TIME1(C),LANE(C),SPEED(C),HEADWAY(C)
& ,LENGTH(C)
      IF (LANE(C).EQ.4)WRITE(34,*)C,TIME1(C),LANE(C),SPEED(C),HEADWAY(C)
& ,LENGTH(C)
      END IF
      END DO
10    DO T=mintime,maxtime-10,10
      K=(T-mintime)/10 +1
      DO LAN=1,3
      DO C=1,max
      IF (SITE(C).EQ.1) THEN
      IF ((TIME1(C)>=T).AND.(TIME1(C)<T+10)) THEN
      IF (LANE(C).EQ.LAN) THEN
      FLOW(K,LAN)=FLOW(K,LAN)+1
      SUMSPD(K,LAN)= SUMSPD(K,LAN)+SPEED(C)
      if((length(c)>520).and.(length(c)<=660))hgv11(k,lan)=hgv11(k,lan)+1
      if (length(c)>660) hgv12(k,lan)=hgv12(k,lan)+1
      END IF
      END IF
      END IF

      IF (SITE(C).EQ.2) THEN
      IF ((TIME1(C)>=T).AND.(TIME1(C)<T+10)) THEN
      IF (LANE(C).EQ.LAN) THEN
      FLOW2(K,LAN)=FLOW2(K,LAN)+1
      SUMSPD2(K,LAN)= SUMSPD2(K,LAN)+SPEED(C)
      if((length(c)>520).and.(length(c)<=660))hgv21(k,lan)=hgv21(k,lan)+1
      if (length(c)>660) hgv22(k,lan)=hgv22(k,lan)+1
      END IF
      END IF
      END IF
      END DO
      AVSPD(K,LAN)=SUMSPD(K,LAN)/FLOW(K,LAN)
      AVSPD2(K,LAN)=SUMSPD2(K,LAN)/FLOW2(K,LAN)
      if (flow(k,lan).eq.0) avspd(k,lan)=0
      if (flow2(k,lan).eq.0) avspd2(k,lan)=0
      END DO
      if ((flow (k,1).eq.0).and.(flow(k,2).eq.0)) goto 15
      WRITE (45,'(5I7,3F9.2,6I7)') T,K,
&FLOW(K,1)*6,FLOW(K,2)*6,FLOW(K,3)*6
&,AVSPD(K,1), AVSPD(K,2), AVSPD(K,3),hgv11(k,1)*6,hgv12(k,1)*6
& ,hgv11(k,2)*6,hgv12(k,2)*6,hgv11(k,3)*6,hgv12(k,3)*6
      WRITE (46,'(5I7,3F9.2,6I7)') T,K,
&FLOW2(K,1)*6,FLOW2(K,2)*6,FLOW2(K,3)*6
&,AVSPD2(K,1), AVSPD2(K,2), AVSPD2(K,3),hgv21(k,1)*6,hgv22(k,1)*6
& ,hgv21(k,2)*6,hgv22(k,2)*6,hgv21(k,3)*6,hgv22(k,3)*6
15    END DO
      PRINT*, FLOW2 (1,1),AVSPD2(1,1),MAX
      END

```

## Program 2: Estimating the average headway and the following distance per lane and based on vehicle type

```

REAL HEADWAY(1500000),distance(1500000)
INTEGER C,TIME1(1500000),LANE
INTEGER SPEED(0:1500000),LENGTH(0:1500000)
integer group1(0:200),group2(0:200),group3(0:200),group4(0:200)
integer Group11(0:200),group12(0:200),group13(0:200),group14(0:200)
real prob1(200),prob2(200),prob3(200),prob4(200)
integer a,h,total

open(24,file='C-C distance.dat')
open(25,file='C-C distance groups.dat')
open(26,file='C-H distance.dat')
open(27,file='C-H distance groups.dat')
open(28,file='H-C distance.dat')
open(29,file='H-C distance groups.dat')
open(30,file='H-H distance.dat')
open(31,file='H-H distance groups.dat')
open(32,file='summary.dat')
open(33,file='C-C summary.dat')
open(34,file='C-H summary.dat')
open(35,file='H-C summary.dat')
open(36,file='H-H summary.dat')
open(21,file='ALL.input')

Write (32,*) 'type ',' sample ',' spacing ',
&' headway','speed '
interval =5
group1=0;group2=0;group3=0;group4=0
sum1=0;sum2=0;sum3=0;sum4=0

a = 450; h =660 ! a is a maximum car length), h is a minimum HGVs length

do c=1,1500000
total =c
READ (21,'(I13,I12,I12,I12,F12.6,I16)')KK1,TIME1(c),LANE
& ,SPEED (C),HEADWAY(C),LENGTH(C)
IF (KK1.EQ.0) THEN
TOTAL=C-1
GOTO 100
END IF
end do
100 do i= 1,15
sp1=i*10;sp2=sp1+10
dist1=0;dist2=0;dist3=0;dist4=0
sum1=0;sum2=0;sum3=0;sum4=0
head1=0;head2=0;head3=0;head4=0
spd1=0;spd2=0;spd3=0;spd4=0
group1=0;group2=0;group3=0;group4=0
prob1=0;prob2=0;prob3=0;prob4=0
group11=0;group12=0;group13=0;group14=0
ave1=0,ave2=0;ave3=0;ave4=0
DO C= 2,total
if (abs(speed(c)-speed(c-1))>5.4)goto 15
distance(c)=(speed(c)*headway(c)/3.6)-(length(c-1)*0.01)
TIMEGAP=3.6*DISTANCE(C)/SPEED(C)
IF (TIMEGAP>2) GOTO 15

```

```

IF (TIMEGAP<0.2) GOTO 15
if((speed(c)<=sp2).and.(speed(c)>sp1)) then

if ((length(c)<=a).and.(length(c-1)<=a)) then ! C-C
sum1=sum1+1
dist1=dist1+distance(c)
head1=head1+headway(c)
spd1=spd1+speed(c)
WRITE(24,'(3I7,f7.2,I7,f7.2,2I7)') c,kk1, time1(c),headway(c),
&speed(c), distance(c), length(c),length(c-1)
DO J=1,20
JJ=J*INTERVAL
IF ((distance(C)>=JJ-INTERVAL).AND.(distance(C)<JJ)) THEN
GROUP1(J)=GROUP1(J)+1
END IF
end do
end if

if ((length(c)<=a).and.(length(c-1)>=h)) then ! C-H
sum2=sum2+1
dist2=dist2+distance(c)
head2=head2+headway(c)
spd2=spd2+speed(c)
WRITE(26,'(3I7,f7.2,I7,f7.2,2I7)') c,kk1, time1(c),headway(c),
&speed(c), distance(c), length(c),length(c-1)
DO J=1,20
JJ=J*INTERVAL
IF ((distance(C)>=JJ-INTERVAL).AND.(distance(C)<JJ)) THEN
GROUP2(J)=GROUP2(J)+1
END IF
end do
end if

if ((length(c)>=h).and.(length(c-1)<=a)) then ! H-C
sum3=sum3+1
dist3=dist3+distance(c)
head3=head3+headway(c)
spd3=spd3+speed(c)
WRITE(28,'(3I7,f7.2,I7,f7.2,2I7)') c,kk1, time1(c),headway(c),
&speed(c), distance(c), length(c),length(c-1)
DO J=1,20
JJ=J*INTERVAL
IF ((distance(C)>=JJ-INTERVAL).AND.(distance(C)<JJ)) THEN
GROUP3(J)=GROUP3(J)+1
END IF; END DO; END IF

if ((length(c)>=h).and.(length(c-1)>=h)) then ! H-H
sum4=sum4+1
dist4=dist4+distance(c)
head4=head4+headway(c)
spd4=spd4+speed(c)
WRITE(30,'(3I7,f7.2,I7,f7.2,2I7)') c,kk1, time1(c),headway(c),
&speed(c), distance(c), length(c),length(c-1)
DO J=1,20
JJ=J*INTERVAL
IF ((distance(C)>=JJ-INTERVAL).AND.(distance(C)<JJ)) THEN
GROUP4(J)=GROUP4(J)+1
END IF
end do; end if; end if

```

```

15     end do
10  do j=1,20
      Group11(j)=group11(j-1)+group1(j)
      prob1(j)=group11(j)/sum1
      Group12(j)=group12(j-1)+group2(j)
      prob2(j)=group12(j)/sum2
      Group13(j)=group13(j-1)+group3(j)
      prob3(j)=group13(j)/sum3
      Group14(j)=group14(j-1)+group4(j)
      prob4(j)=group14(j)/sum4
      END do
      ave1=dist1/sum1;avehead1=head1/sum1;avespeed1=spd1/sum1
      if (sum1.eq.0) then
      ave1=0;dist1=0;avehead1=0;avespeed1=0;end if
      ave2=dist2/sum2;avehead2=head2/sum2;avespeed2=spd2/sum2
      if (sum2.eq.0) then
      ave2=0;dist2=0;avehead2=0;avespeed2=0;end if
      ave3=dist3/sum3;avehead3=head3/sum3;avespeed3=spd3/sum3
      if (sum3.eq.0) then
      ave3=0;dist3=0;avehead3=0;avespeed3=0;end if
      ave4=dist4/sum4;avehead4=head4/sum4;avespeed4=spd4/sum4
      if (sum4.eq.0) then
      ave4=0;dist4=0;avehead4=0;avespeed4=0;end if
      print*, "SAMPLE = ",TOTAL, sum1,sum2,sum3,sum4
      DO J=1,20
      JJ=J*INTERVAL
      WRITE(25,*) JJ, GROUP1(J),group11(j),prob1(j),(sp1+sp2)/2
      WRITE(27,*) JJ, GROUP2(J),group12(j),prob2(j),(sp1+sp2)/2
      WRITE(29,*) JJ, GROUP3(J),group13(j),prob3(j),(sp1+sp2)/2
      WRITE(31,*) JJ, GROUP4(J),group14(j),prob4(j),(sp1+sp2)/2
      end do

      Write (32,*) 'c-c',sum1, ave1,avehead1,avespeed1
      Write (32,*) 'c-h',sum2, ave2,avehead2,avespeed2
      Write (32,*) 'h-c',sum3, ave3,avehead3,avespeed3
      Write (32,*) 'h-h',sum4, ave4,avehead4,avespeed4
      Write (33,*) avespeed1,'c-c',sum1, ave1,avehead1
      Write (34,*)avespeed2,'c-h',sum2, ave2,avehead2
      Write (35,*)avespeed3,'h-c',sum3, ave3,avehead3
      Write (36,*)avespeed4,'h-h',sum4, ave4,avehead4
      end do

      END

```

## Appendix C : Computer program used for estimating the critical occupancy

```

INTEGER flow(28000),SUMOCCfree(200), SUMOCCcon(200), occ(28000)
INTEGER GROUPcon(200), GROUPfree(200), C, TRIAL
REAL AVEOCCfree(200),AVEOCCcon(200)
OPEN (21,file='occ.input')
OPEN (23,file='flow.input')
OPEN (22,file='input check.DAT')
OPEN (20,file='RESULTS of congested.DAT')
OPEN (24,file='RESULTS of free.DAT')
INTERVAL=100      ! FOR INTERVAL OF FLOW CALCULATIONS
TRIAL=22          ! TRIAL VALUE OF CRITICAL OCCUPANCY
NOOFIN=14400     ! NUMBER OF INPUTS
DO C= 1,NOOFIN
  READ (21,'(I5)') occ(C)
  READ (23,'(I5)')flow(C)
  WRITE (22,'(2I5)')c,flow(C),occ(C)
  DO J=1,130
    JJ=J*INTERVAL
    IF ((FLOW(C)>=JJ-INTERVAL).AND.(FLOW(C)<JJ)) THEN
      IF (OCC(C) > TRIAL) THEN
        GROUPcon(J)=GROUPcon(J)+1
        SUMOCCcon(J)=SUMOCCcon(J)+OCC(C)
      ELSE
        GROUPfree(J)=GROUPfree(J)+1
        SUMOCCfree(J)=SUMOCCfree(J)+OCC(C)
      END IF; END IF
1000  END DO
      END DO
10    DO J=1,130
      JJ=J*INTERVAL
      IF (GROUPcon(J).NE.0) THEN
        AVEOCCcon(J)=SUMOCCcon(J)/GROUPcon(J)
      ELSE
        GOTO 100
      END IF
      WRITE(20,*) AVEOCCcon(J),JJ-INTERVAL*0.5
      SUMcon=SUMcon+GROUPcon(J)
100  END DO
      DO J=1,130
      JJ=J*INTERVAL
      IF (GROUPfree(J).NE.0) THEN
        AVEOCCfree(J)=SUMOCCfree(J)/GROUPfree(J)
      ELSE
        GOTO 2000
      END IF
      WRITE(24,*) AVEOCCfree(J),JJ-INTERVAL*0.5
      SUMfree=SUMfree+GROUPfree(J)
2000 END DO
      PRINT *, TOTAL,SUMcon, SUMfree
      END

```



### Appendix D : Effectiveness of ramp metering

Figure D-1 to Figure D-3 show the average speed and occupancy values for the M56 J2 (two lanes), the M60 J2 (three lanes) and the M6 J23 (three lanes). Similar to the facts which have been discussed in section 4.9.3, these figures suggest that ramp metering could not prevent the onset of traffic congestion at these sites.

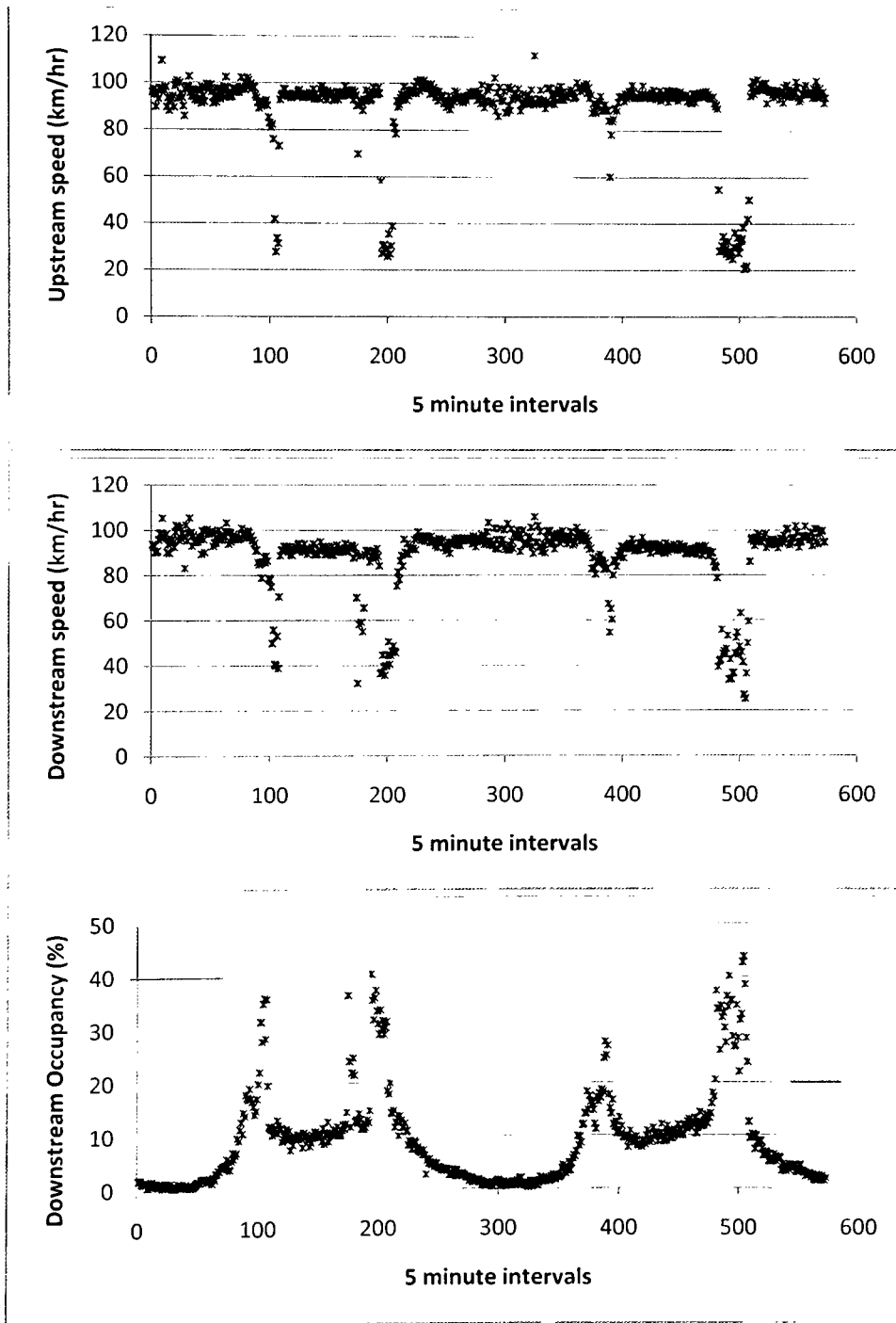

Figure D-1 Speed and occupancy values for the M56 J2 (2 lanes)

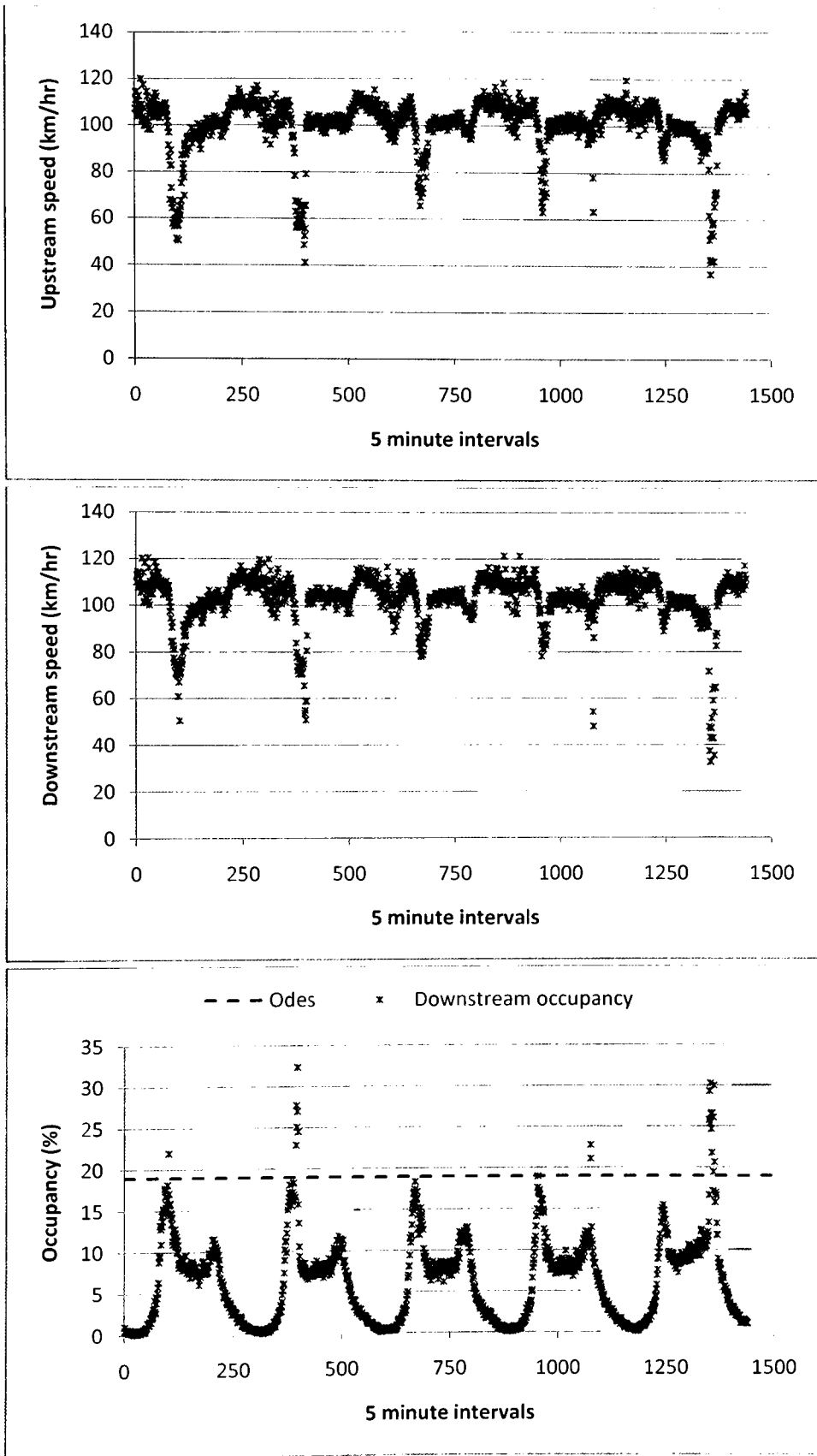

Figure D-2 Speed and occupancy values for the M60 J2 (3 lanes)

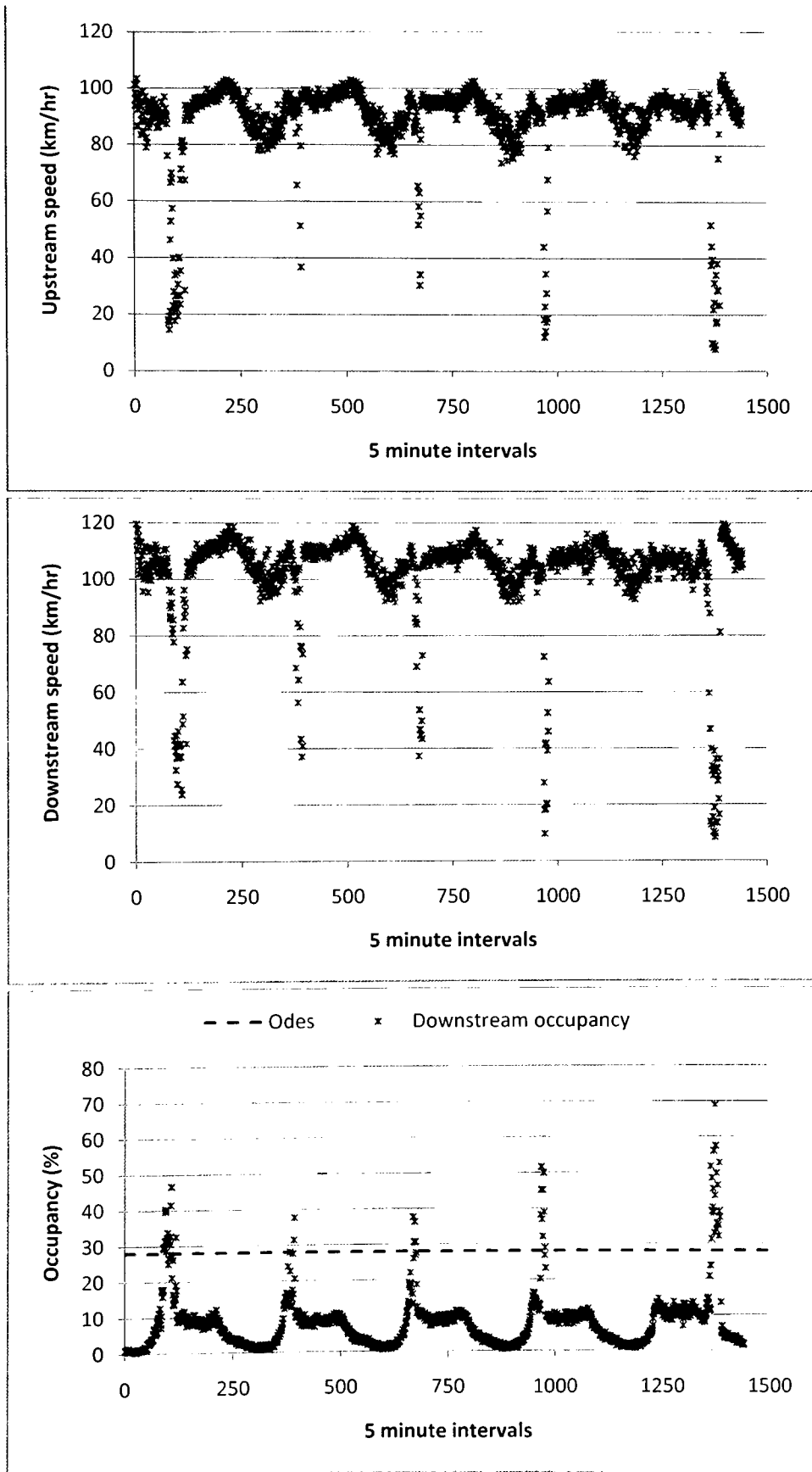

Figure D-3 Speed and occupancy values for the M6 J23 (3 lanes)

## Appendix E : Verification of the car following rules

Chakroborty and Kikuchi (1999) suggested that car following rules (CFR) should be tested against logical behaviour before comparing the model with data obtained in the field. Wu *et al.* (2003) suggested the same idea when they applied “conceptual validation” to trace the behaviour of their model before transferring to a later process of calibration with real data. In this study, similar points to those used in the above two studies were used as follows:

### a. *Local stability*

This examines the ability of a follower (in the model) to react to the disturbance produced by the acceleration/deceleration rates of a leading vehicle and the ability of the follower to recover the desired speed and distance after the ending of the disturbance. In order to test the ability of the model to show such behaviour, it is assumed that the leading vehicle applied a normal deceleration rate of  $-2.4 \text{ m/sec}^2$  for a period of 5 seconds and then applied an acceleration rate of  $1.2 \text{ m/sec}^2$  to return to its original speed. The results shown in Figure E-1 suggest the ability of CFR to represent such behaviour based on the acceleration and deceleration behaviour of the follower with respect to the speed of the leader and the clear spacing between the two vehicles.

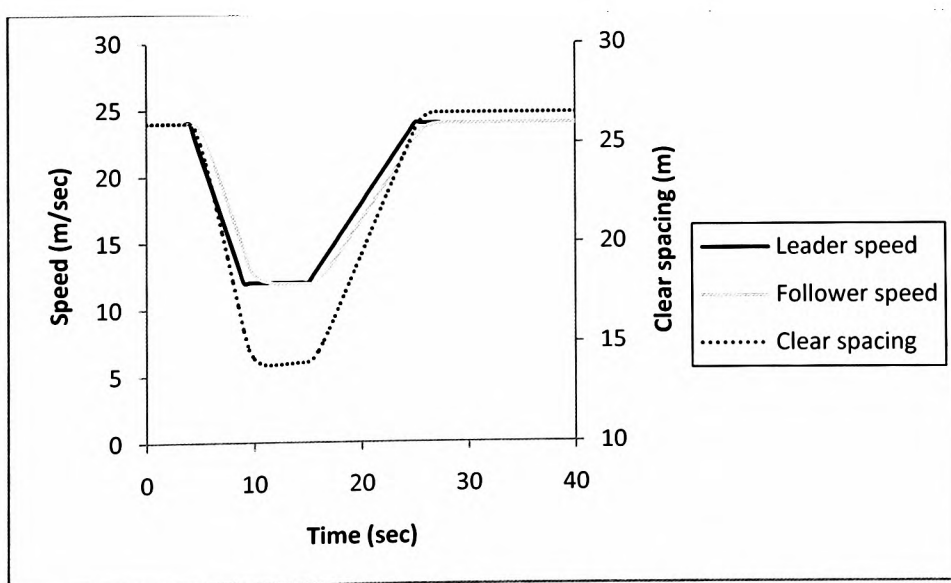

Figure E-1 Testing of the model stability

### b. *Reacting to the following distance*

This describes the ability of a following vehicle (in the model) to react to situations where the clear spacing between the vehicle and its leader is lower than that desired for any

reason (such as forced lane changing occurring). To examine such behaviour, it is assumed that the initial spacing between the two vehicles is 15m which is lower than the desired spacing required with an assumed initial speed of 24 km/hr. Figure E-2 shows that the follower decelerated in order to recover his/her desired spacing. Also, when the difference in speed between the follower and the leader became 2 m/sec (24 m/sec for the leader and 22 m/sec for the follower), the follower kept a constant speed as there is no need to apply further deceleration rates with such a difference in speed (according to the car following rules described in section 5.8). At the time of 5 seconds, the follower started increasing his/her speed because the spacing became higher than desired.

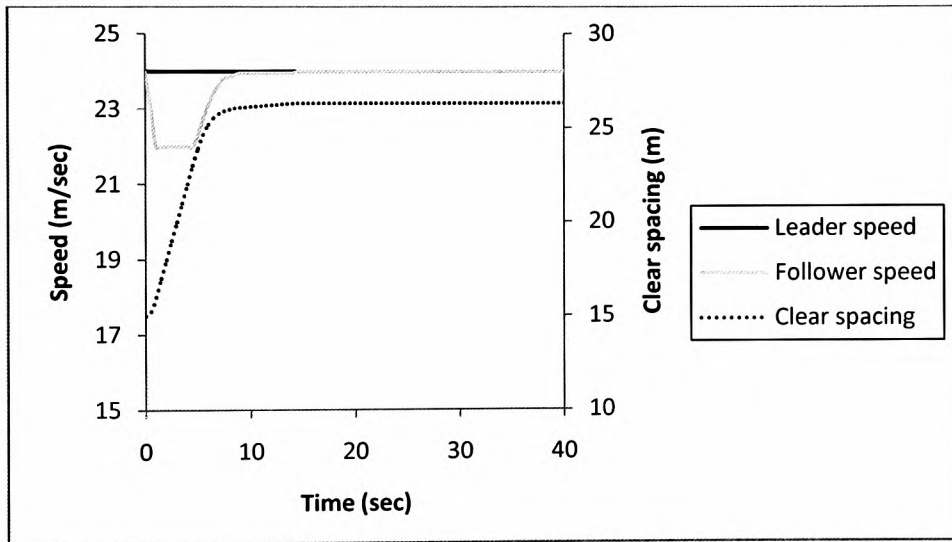

Figure E-2 Testing the model behaviour according to the following distance