

Proceedings of the
**Salford Postgraduate Annual
Research Conference**

(SPARC)

2010

University of Salford





University of Salford
A Greater Manchester University

Proceedings of the Salford Postgraduate Annual Research Conference (SPARC) 2010

© 2011 University of Salford. All rights reserved.

ISBN: 978-1-4477-8072-4

Published by
The University of Salford
Salford
Greater Manchester
M5 4WT
United Kingdom

Preface

Postgraduate research is the dynamo that drives innovative new work at good universities, and we are particularly proud of the work of our postgraduate students. SPARC brings together the best of this research across key fields that well express our university's strong themes of enquiry. The annual SPARC conference provides a dynamic forum for research students and supervisors to present and discuss new knowledge, fostering connections across disciplines that will open up areas for the future.

Professor Martin Hall

Vice-Chancellor, University of Salford

Welcome to the 2010 proceedings of the Salford Postgraduate Annual Research Conference (SPARC). This selection of papers provides an excellent indication of the scope and scale of the two day interdisciplinary conference, and testifies to the quality and intellectual rigour of the research projects showcased there.

One of the defining characteristics of SPARC is its openness to all disciplines and research topics. This enables the participants to set the priorities of the conference, and allows for natural themes to emerge. This broad-ranging selection of thirty papers spans a wealth of disciplines – from life sciences, management, finance, computing, education, and the built environment through to sociology, art and literature studies. This publication offers a snapshot of that range: alongside Salford's researchers, there are contributions from postgraduates at the Universities of Liverpool John Moores, Exeter, Bolton University, Cardiff University, Suffolk and Limerick Institute of Technology in Ireland.

As well as facilitating conversations between disciplines, SPARC offers space for informal and academic networking between researchers from different universities, with presenters drawn from different regions of the UK and internationally. Providing an environment for cross - institutional engagement is just one of the ways in which the annual conference supports researcher development. It is an opportunity to develop individual research projects, giving presenters the chance to test out ideas on new audiences, receive valuable feedback from the academic community, make their work known and consequently raise their research profile. At the same time, the conference is also about professional development – allowing early career academics to develop all important conference presentation skills, to practise the art of translating complex research ideas into a clear and concise format, and to communicate those ideas to audiences outside of their immediate specialism. This has valuable implications in terms of employability, encouraging the development of the kind of transferable skills that researchers are increasingly expected to demonstrate.

In developing the conference presentations into full papers for this publication, the contributors have expanded upon their research questions and findings in more detail, allowing readers privileged insight into a whole host of exciting and, in many cases, very new projects. The aim is for the proceedings to extend conversations well beyond the conference itself, by opening up new audiences and readerships for this emerging research. We are pleased to make the proceedings freely available online, and believe that the open

access ethos of the unrestricted sharing of knowledge is very much in keeping with the spirit of the conference.

If you would like to find out more information about the annual conference and details other support for early career researchers offered by Salford's Graduate Studies team, please visit our website at <http://www.pg.salford.ac.uk>

Dr Victoria Sheppard

Dr Sonja Tomaskovic

Research Skills Coordinators, University of Salford

Contents

Evaluation of Car-following Models Using Field Data	
Hamid A.E. Al-Jameel	8
Estimation of critical occupancy values for UK motorways from traffic loop detectors	
Jalal Al-Obaedi and Saad Yousif	22
The Effects of Residential Location on Total Person Trip Rates	
Firas Asad	34
Factors affecting the excellence of service quality at Syrian Public Banks	
Dima Al-Sayeed Assad.....	50
Little Dorrit’s Rigaud: Stock Melodramatic Villain or Clinical Portrait of Psychopathy?	
Abby Bentham.....	68
Unravelling ecological genetics in the face of environmental change: the case of the common toad (Bufo bufo)	
Robert Coles.....	76
Evaluation of Training Programmes Provided for the Academic Staff of Libyan Universities	
Majda Elferjani and Les Rudock.....	88
The Methodology of Identifying of the Factors of Organisational Conflict in the Libyan Cement Industry	
Munira Elmagri and David Eaton.....	100
Preliminary assessment of the food control systems in Libya	
Nagat A Elmsallati.....	116
An examination the impact the Nature and Particularities of Banking Services Industry on the Use of Performance Measurements: Libyan Evidence	
Gumma Fakhri, Karim Menacere and Roger Pegum.....	124
Identification of Wheel-Rail Contact Condition Using Multi-Kalman Filtering Approach	
Imtiaz Hussain and T. X. Mei.....	144
A novel single step process for making CuInSe₂ absorbing layers for solar cell applications	
Sreejith Karthikeyan, Arthur Hill and Richard Pilkington.....	156

Attitudes of staff members towards the embracing of Electronic Learning at the Libyan Higher education	
Abdulbasit S. Khashkhush	170
Detection of <i>Echinococcus granulosus</i> in farm dogs in South Powys, Wales using coproELISA and coproPCR	
Wai-San Li, Belgees Boufana, Helen Bradshaw, Arjen Brouwer, David Godfrey and Philip Craig.....	184
Investigating the Emerging Issues that Affect the Online Consumers	
Vincent Lui and Mathew Shafaghi.....	196
Bloodless Minutes of Global-local Fear: Identity in the Novel Senza sangue, the Film Vier Minuten and the Music Video The Fear	
Mattia Marino.....	210
Coping or exiting BMES response to discrimination in construction	
Paul Missa and Vian Ahmed.....	222
Structural impact study of “ideal” 3D aluminium foam	
Sathish Kiran Nammi, Peter Myler and Gerard Edwards.....	238
An Application of the Activity-Based Costing for the Management of Project Overheads to Increase Profit during the Construction Stage	
Nyoman M. Jaya, Chaminda P. Pathirage and Monty Sutrisna.....	248
Exploring the link between organizational learning and sustainable construction project	
Alex Opoku and Chris Fortune.....	268
Mapping minimal music through the lens of postmodernity	
Alexis Paterson.....	284
Risk assessment in natural hazard areas for the resettlement programmes	
Panitp Piyatadsananon, Dilanthi Amaratunga and Kaushal Keraminiyage.....	298
Web 2.0: the use of online Social Networking Sites (SNSs) for marketing Higher Education (HE)	
Arash Raeisi.....	312
Implementing the Process of Knowledge Sharing within Small Construction Consultancy Companies in Ireland	
Rita Scully and Farzad Khosrowshahi.....	330
The Efficiency of Libyan Commercial Banks in the Context of Libyan WTO Accession	
Saleh R. Abida and Gianluigi Giorgioni.....	346

An ethnographic study of the culture in a Diagnostic Imaging Department (DID) – some personal reflections	
Ruth M Strudwick, Stuart Mackay and Stephen Hicks.....	360
The antecedents for knowledge sharing behaviour among Malaysian undergraduate Students	
Nor Intan Saniah Sulaiman.....	372
Auxetic Materials and Engineering Applications	
Muhammet Uzun.....	396
Growing Ethnopolitical Conflict and the Challenge of ‘One Nigeria’: Politics of State Building in a Multiethnic Society, 1960-2010	
Ali Simon Bagaji Yusufu.....	412
Value Destruction from Spin-offs	
Nadisah Zakaria and Glen Arnold.....	424

Evaluation of Car-following Models Using Field Data

Hamid A.E. Al-Jameel, *University of Salford*

Abstract

Traffic congestion problems have been recognised as a serious problem in all large urban areas. It can significantly reduce urban mobility. Therefore, it has become a major concern to the transportation and business communities and to the public in general. Different techniques have been proposed to alleviate this problem. One of these techniques is a traffic simulation. It has been used effectively as it can represent real life, to some extent, and apply different strategies without the need to make physical changes. Car-following models represent the basic unit that governs the longitudinal movement for each traffic simulation model. The efficiency of a traffic simulation model mainly depends on its core units: car-following and lane changing.

In this study, three car-following models (namely, CARSIM, WEAVSIM and PARAMICS) were tested. The first two of these models were rebuilt using Visual Compact FORTRAN Version-6.5. The models were tested using three different sets of data from single lane traffic. These sets of data have been collected using two different methods of collecting data from three regions. In addition, different traffic conditions have been included in this data such as high speed, low speed and “stop and go conditions”.

The results indicated that CARSIM gave the most accurate representation of real life situations. Therefore, the assumptions of this model were adopted in a newly developed model to represent traffic behaviour in weaving sections to evaluate the factors affecting the weaving capacity.

Keywords:

Traffic micro-simulation, car-following model, CARSIM and WEAVSIM

1. Introduction

Traffic congestion problems have been recognised as a serious problem in all large urban areas. It can significantly reduce urban mobility. Therefore, it has become a major concern to the transportation and business communities and to the public in general. Different techniques have been proposed to alleviate this problem. One of these techniques is a traffic simulation. It has been used effectively because it can

represent real life, to some extent, and applies different strategies without the need to make physical change on site before implementing such strategies. Car-following model represents the basic unit that governs the longitudinal movement for each traffic simulation model. The efficiency of any traffic simulation model relies mainly on the accuracy of its car-following and lane changing assumptions (Panwia and Dia, 2005).

In this study, the algorithms of three car-following models are explained briefly and the results of testing these models using different sets of data are also illustrated.

2. Car-following models

Several car-following models have been proposed to govern the longitudinal movement of vehicles in a traffic stream as shown in Figure 1. Pipes (1967) suggested that the follower normally maintained safe time headway of 1.02s from its leader. This value was extracted from a recommendation in the California Vehicle Code (Choudhury, 2007). These models were then followed by various models with different theoretical backgrounds and assumptions.

In general, car-following models can be classified into three groups; sensitivity-stimulus, safety or non-collision criteria and psychophysical models (Olstem and Tapania, 2004).

Firstly, sensitivity-stimulus models, these models were introduced by GM Research Laboratories and represent the basis for most models to date. The Gazis-Herman-Rothery (GHR) model represents this group. This model was tested under three sets of data with different parameters (linear and non-linear). Different thresholds have been suggested to indicate the following behaviour from free-following (Al-Jameel, 2009). However, this model is still unable to mimic most traffic conditions. In addition, there is no obvious connection between the model parameters and driver's characteristics as reported by Gipps (1980).

Secondly, safety or non-collision criteria models assume that a driver maintains a safe distance between him/her and the leader to prevent a collision at any time of movement (Brackstone and McDonald, 1999). CARSIM and WEAVSIM are examples for this group.

Thirdly, psychophysical models assume that a driver will respond (acceleration or deceleration) after a certain threshold. This threshold can be represented by a relative speed or a distance (Brackstone and McDonald, 1999). PARAMICS is a good example of this group.

Figure 1 Longitudinal (headway) space between leading and following vehicles.

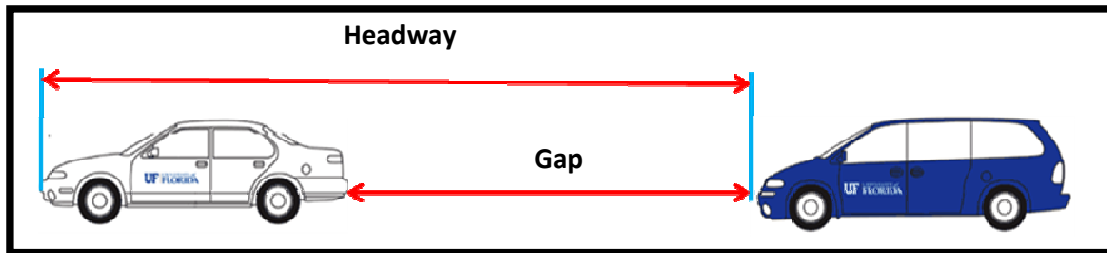

The algorithms of CARSIM, WEAVSIM and PARAMICS are briefly explained in the following sub-sections.

2.1. CARSIM model

CARSIM (CAR-following SIMulation) is a freeway simulation program. This model has been developed according to some of the assumptions that have been introduced by Benekohal and Treiterer (1988). In the model, five situations were used to describe the degree of response (acceleration or deceleration). These situations are:

A. If there is no restriction from the preceding vehicle, the driver will drive to reach his / her desired speed or speed limit. This speed represents the maximum speed that driver tries to reach it when there are no other constrains such as a vehicle ahead, speed limit, and bad weather conditions.

The non-collision criterion that prevents the following vehicle from colliding with the leader at any time even if the latter brakes suddenly. The deceleration will be calculated according to Equation 1.

$$\begin{aligned}
 & \text{POS}_L - (\text{POS}_F^i + \text{SP}_F + 0.5 \cdot \text{ACC}_s \cdot \text{Dt}^2) - L - \text{BS} \geq \text{max. of} \\
 & (\text{SP}_F + \text{ACC}_s \cdot \text{Dt}) \text{RT or} \\
 & (\text{SP}_F + \text{ACC}_s \cdot \text{Dt}) \text{RT} + (\text{SP}_F + \text{ACC}_s \cdot \text{Dt})^2 / (2\text{MD}_F) - (\text{SP}_L)^2 / (2\text{MD}_L) \dots \text{Equation 1.}
 \end{aligned}$$

Where:

POS_L = the position of a leader vehicle

POS_F^i = the position of a follower vehicle at the beginning of the current scanning time.

ACC_s = acceleration/ deceleration (m/sec^2).

MD_F or MD_L = maximum deceleration for follower and leader, respectively (m/sec^2).

SP_L = speed of leader (m/sec).

RT= reaction time (sec).

Dt= scanning time (0.5 sec.).

BS= buffer space.

L=length of leading vehicle.

A. Vehicle mechanical ability conditions

As the vehicle generates in the system, the type of each vehicle is assigned also for each vehicle as passenger car and heavy vehicle. Passenger car has more mobility in the movement and manoeuvre because of its short and light mass. These differences in characteristics have been translated in the amount of acceleration/ deceleration that can be achieved by each type of vehicles. Therefore, different values of acceleration/ deceleration have been assigned to represent the characteristics of movement for passenger and heavies as reported by ITE (1999).

B. Moving from stationary conditions

When vehicle stops in the platoon conditions and then tries to move due to the movement of leading vehicle, its acceleration in this case depends mainly on the type of vehicle. Therefore, the amount of delay that is taken by each vehicle to start movement is called start-up delay. Yousif (1993) has reported that 1 second is suitable for driver with shorter reaction time and 2 second is suitable for the rest vehicles. Therefore, the same values have been adopted in this study.

The headway of vehicles in the slow speed or stationary conditions should always be more than the buffer space. This buffer space has different values ranging from 3 m to 1.8 m (Benekohal, 1986 and Yousif, 1993). In this study, it was used as 1.5 m.

Basically, the acceleration from each situation is calculated and the minimum one will govern the situation. For example, if the acceleration resulting from reaching a desired speed is higher than the acceleration resulting from the mechanical ability of vehicle, then the later acceleration will govern the situation.

Aycin and Benekohal (2001) examined five car-following models, NETSIM, INTRAS, FRESIMS, CARSIM and INTELSIM, in terms of the stability, performances and characteristics of car-following behaviour. They found that vehicles in NETSIM and CARSIM car-following models have

approximately the same headway which equals to the reaction times. In addition, they also reported that INTRAS and FRESIM representing unrealistic acceleration variations and high maximum decelerations. Then, they concluded that CARSIM represents greater headway than NETSIM and provide more realistic results. Finally, they argued that INTELSIM can provide similar speed and headway to those of drivers.

2.2 WEAVSIM Model

The car-following incorporated in this model is based on a combination of two conditions (Zarean, 1987 and Iqbal, 1994):

The following vehicles always seek a desired headway which will be a function of vehicle speed, relative speed and vehicle's type.

A collision criterion will be applied to avoid a collision.

By using these two conditions, each speed and location of any vehicle will be determined. Thus, three conditions are used in this model (Zarean, 1987 and Iqbal, 1994):

As the leader has come to a complete stop the following vehicle should also come to stop while keeping space headway of at least equal to the length of the leader plus a safety distance (S.D).

$$POS_L - POS_F^f \geq L + BS \dots \dots \dots \text{Equation 2.}$$

$$POS_F^f = POS_F^i + SP_F^2 / 2 * ACCs \dots \dots \dots \text{Equation 3.}$$

By substituting in Equation 4 then:

$$ACCs = - SP_F^2 / (2(POS_L - POS_F^f - L - BS)) \dots \dots \dots \text{Equation 4.}$$

Where;

POS_F^f = position of the following vehicle at the end of current scanning time interval.

When the updated speed of the leader is greater than zero but less than the current speed of the follower the follower should decelerate to avoid a collision. The safe space headway is calculated as following:

$$POS_L - POS_F \geq L + BS + RT * SP_F^2 / 2 * ME_D - SP_L^2 / 2 * ME_D \dots \dots \dots \text{Equation 5.}$$

The basic concept here is that a follower maintains headway equal to the length of vehicle plus buffer spacing. In order to determine the deceleration the updated position of the follower must be substituted into the above equation.

As the updated speed of the leader is greater than the current speed of the follower, the space headway for this case can be expressed as:

$$POS_L - POS_F^f \geq L + BS + RT * SP_L \dots\dots\dots \text{Equation 6.}$$

2.3 PARAMICS Model

PARAMICS is traffic simulation software that is widely used to design and analyse different highway facilities such as intersection, merging section and roundabouts. A brief description

of car-following model in terms of acceleration and deceleration was discussed in Panwia and Dia (2005).

Figure 2 Car-following phase-space diagram (Panwai and Dia, 2005).

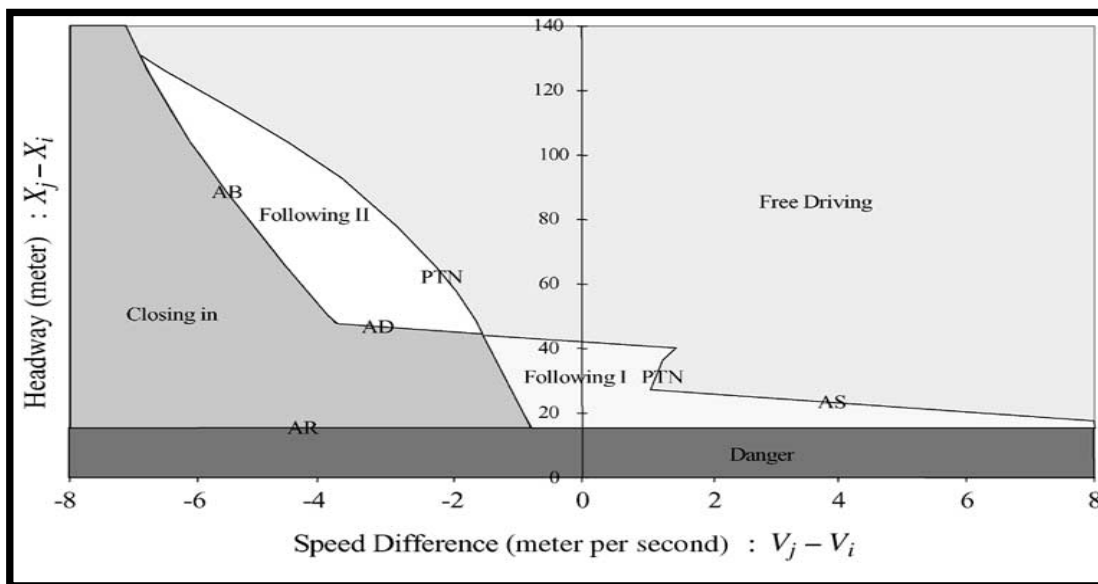

Five situations were investigated at which there were different responses of the following vehicles which were noted according to different thresholds. Figure 2 indicates the location of vehicles depending on the relative speed and relative headway. After identifying the vehicles' situation in Figure 2, the correct equation of the response can be chosen. For more details see ((Panwia and Dia, 2005).

3. Rebuilding The Models

Visual Compact FORTRAN has been used to rebuild CARSIM and WEAVSIM depending on the algorithms of these models as discussed in section 2. In each model, a warm-up and cool-off sections have been used to reduce the error from unstable conditions in the start and end of the sections. A warm-up time is also used to reduce the instability that may occur in the start time of the program.

4. Statistical Tests

To assess the difference between the simulation outputs with the field data, two measures are used: the Root Mean Square Error (RMSE) and Error Metric (EM) (Panwai and Dia, 2005). These parameters can be determined as shown in Equation 9 & 10.

$$RMSE = \sqrt{\frac{1}{N} \sum_{n=1}^N (Ds - Df)^2} \dots\dots\dots \text{Equation 8.}$$

$$EM = \sqrt{\sum \left(\log \frac{Ds}{Df} \right)^2} \dots\dots\dots \text{Equation 9.}$$

Where;

Ds = simulated distance (m).

Df = observed distance (m).

The EM is used by Panwai and Dia (2005) as a measure of precision between the simulated and field. However, this measure is inadequate as noted during this study because it is affected by the number of points which are considered in the comparison of simulated data and field data. Consequently, the values of RMSE were adopted in this study rather than the EM. As the value of RMSE increases, the difference between the field and simulated data increases, too.

5. Data sets

Three models of car-following have been tested via three sets of field data. These are:

5.1. First Set of Data

This data was collected by the Robert Bosch GmbH Research Group under stop-and-go traffic conditions on a single lane in Stuttgart, Germany during an afternoon peak. It was gathered by using an instrumented vehicle to record the relative speed and space headway. Moreover, this data has been used to test four car-following models: AIMSUN (v4.15), VISSIM (v3.70) {Wiedemann 74& 99} and PARAMICS (v4.1) (Panwia and Dia, 2005). This data consists of two vehicles: the leader and follower. This set of data provides a comparison of the distance between the leader and follower as shown in Figure 3.

This set of data is characterised by:

- A range of speed between 0 and 60 kph.
- Three stop situations.
- Test duration of 300 seconds.

Figure 3 Field data via simulated data (CARSIM, WEAVSIM and PARAMICS).

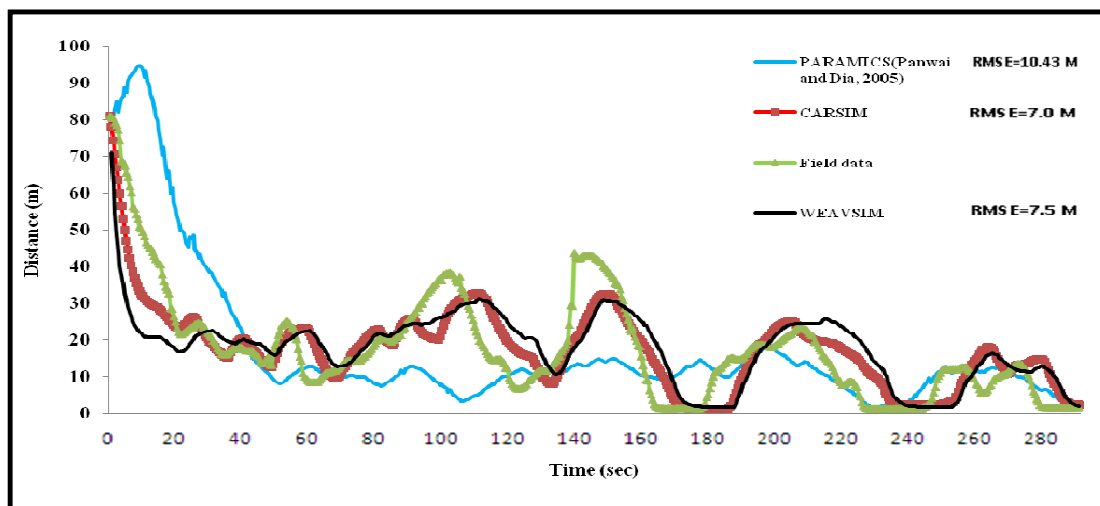

Figure 3 represents the field data from Germany and the results from the three simulation models. The field data ranges from free-flowing conditions in the first part of curve (up to 30 sec.) to a slow speed condition at the end of test. Through the slow speed conditions, the leader came to a complete stop at three positions as shown in Figure 3.

PARAMICS was tested by Panwia and Dia (2005) with this set of data. The results, as shown in Figure 3 indicate a significant difference between PARAMICS and field data. The first variation is within the free-flow region up to 30 seconds. This shows bad handling of the model under free-flow conditions. The second variation is within the slow speed and stop/go conditions. Again, the behaviour of the model tends to give a shorter headway than what the real data suggests. Therefore, in free-following the model seeks larger headway than real data and vice versa.

Then, WEAVSIM is compared with field data as shown in Figure 3. This model can represent the free-following case better than PARAMICS. The main difference between the model and PARAMICS is that WEAVSIM adopts a shorter headway than the latter. However, there is a difference between the model and the field data as shown in Figure 3. Another factor, which determines the behaviour of this model in such a case, is the reaction time. In the case of increasing this factor, the curve seems to give better results but this leads to more discrepancies in the slow speed region.

On the other hand, the RMSE for PARAMICS is 10.43 m whereas it is 7.5 m for WEAVSIM. So the latter is better than PARAMICS in the amount of error between field and simulated data.

A third model, CARSIM represents the driver behaviour more accurate than other models as shown in Figure 3. This model is similar to WEAVSIM but it is better than the latter in different experimental situations. Moreover, the value of RMSE for CARSIM is less than WEAVSIM's model (RMSE=7.0 m).

5.2 Second Set of Data

Two experiments were conducted to gather two sets of data by using an instrumented vehicle (Sauer et al., 2004). Data has been collected by the following vehicle in this test and the previous one. This data represents two vehicles: leader and follower.

The characteristics of this set of data are:

- A range of speed between 27 and 108 kph
- The duration of the test is 162 sec.
- No-stopping situations

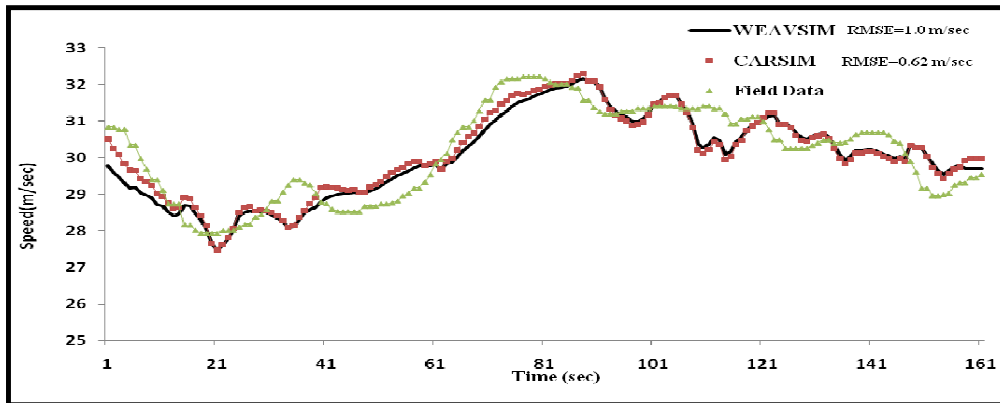

Figure 4 Field data via simulated data (CARSIM and WEAVSIM).

Figure 4 illustrates the comparison between field data and simulated data, CARSIM and WEAVSIM. In this set of data, both CARSIM and WEAVSIM gave reasonably similar results. However, the value of RMSE of CARSIM of 0.63 m/sec is less than that of WEAVSIM (1.0 m/sec). Therefore, CARSIM is considered better than WEAVSIM in such situation.

5.3. Third Set of Data

A new method of collecting data was adopted in this set of data from the USA. In this method, hidden video cameras, they were covered by other things, were used to monitor the behaviour of drivers to avoid the effect of influencing the drivers who were used as part of the experiment. In this method of collecting data, valuable information was obtained because the instrumented test vehicle is the lead vehicle. The driver of the lead vehicle can be any normal driver who can drive legally.

The specifications of this set of data are:

- A range of speed between 14 and 43 kph.
- The space distance between vehicles ranging from 3 to 15m.
- The duration of the experiment is 176 seconds.

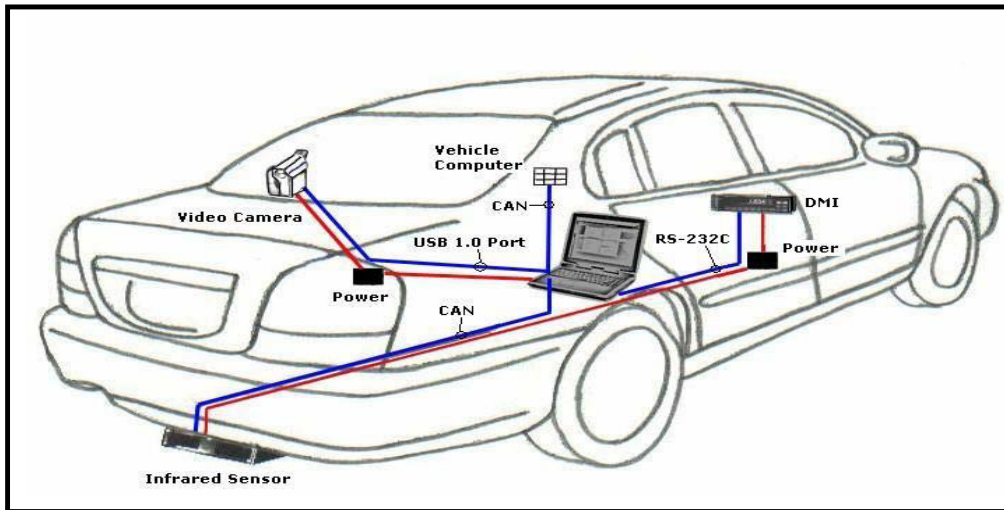

Figure 5 Test vehicle apparatus and connectivity diagram (Kim, 2005).

In this case, the following vehicle was the monitored vehicle and the driver of this vehicle was not made aware that he/she was monitored by others. Figure 5 indicates the components of the monitored system in the leading vehicle.

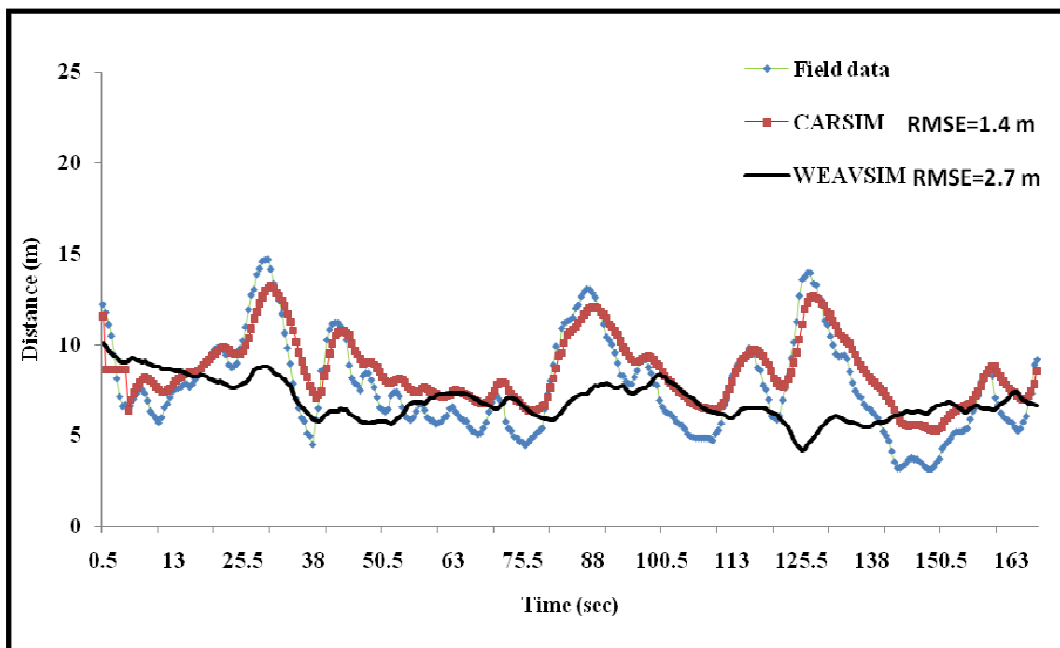

Figure 6 The field data via simulated data (CARSIM and WEAVSIM)

Figure 6 shows the results of the two models compared with the field data. The most important point here is that this data represents slow speed conditions. Thus, the CARSIM model here gave better results than WEAVSIM. In addition, the value of RMSE for CARSIM is 1.4m while that for WEAVSIM is 2.7m. Therefore, CARSIM is preferred for this test.

Table 1 Results of simulated models with field data.

No. Of Tests	Test one (First set)			Test two (Second set)		Test three(Third set)	
	CARSIM	WEAVSIM	PARAMICS	CARSIM	WEAVSIM	CARSIM	WEAVSIM
RMSE	7.0m	7.5m	10.43m	0.62m	1.0m	1.4m	2.7m

The results of the RMSE for the three tests are summarised in Table 1. Firstly, the maximum value of RMSE among other models for the test one is belong to PARAMICS. This means that PARAMICS is the worst one because as the value of RMSE increases, its difference with field data increases, too. Moreover, the first test is better than other tests because the second set of data includes different of traffic conditions ranging from free following to stop-and-go conditions. Therefore, CARSIM is the best one among the other models under study because it has the lowest value of RMSE in this test and also in the second and third test as shown in Table1.

6. Conclusions and Recommendations

In this study, two car-following models have been developed using Visual Compact FORTRAN (version 6.5) based on algorithms of CARSIM and WEAVSIM to produce a simulation model. This simulation model is able to mimic the reality using visual animation in representing the movements of vehicles, spacing between vehicles, speeds of vehicles and other characteristics. These two models with package of PARAAMICS have been tested with three sets of data. The main conclusions of these tests are:

PARAMICS gives the worst representation of the reality in terms of graphical and statistical test (i.e., RMSE =10.43m) among other models.

CARSIM model gives the best results among other models (RMSE = 7.0m).

Finally, the developed simulation model CARSIM could be used in representing the car-following model better than WEAVSIM and PARAMICS. Therefore, the assumptions which CARSIM is based on could be used in the newly developed model to evaluate the effect on capacity and delays of weaving sections on motorways. However, the difference between field and simulated data is still higher and there is a need

for more improvements for the developed model CARSIM to get a less difference than that in the current study.

7. References

- Al-Jameel, H.A. (2009) Examining and Improving the Limitations of the Gazis-Herman-Rothery Car-following Model. **SPARC 2009, University of Salford.**
- Aycin, M.F. and Benekohal, R.F. (2000) Analysis of Stability and Performance of Car Following Models in Congested Traffic. **Proceedings of the 79th Annual meeting of the Transportation Research Board, January, Washington DC, USA.**
- Benekohal, R.F., and Treiterer (1988) CARSIM: Car-following Model for Simulation of Traffic in Normal and Stop –and –go Conditions. **Transportation Research Record 1194, Washington, D.C.**
- Brackstone, M. and McDonald, M. (1999) Car-following: a historical review. **Transportation Research Part F, Vol. 2, pp. 181-196.**
- Choudhury, C.F. (2007) Modelling Driving Decision with Latent Plans. **Thesis (PhD), Massachusetts Institute of Technology, USA.**
- Gipps, P.G. (1981) A Behavioural Car-Following Model for Computer Simulation. **Transportation Research Part B, Vol.15, pp.105-111.**
- Iqbal, M.S. (1994) Analytical and Simulation Model of Weaving Area Operations Under Non-Freeway Conditions. **Dissertation (PhD), New Jersey Institute of Technology, USA.**
- Kim, T. (2005) Analysis of Variability Car-following Behaviour over Long-term Driving Manoeuvres . **Thesis (PhD), University of Maryland.**
- Olstam, J.J. and Tapani, A. (2004) Comparison of Car-following Models. **Swedish National road and Transport Research Institute.**
- Panwai, S. and Dia, H. (2005) Comparative Evaluation of Microscopic Car-Following Behaviour. **IEEE Transactions on Intelligent Transportation Systems, Vol. 6, No. 3, pp. 314-325.**
- Pipes, L. A. (1967) Car Following Models and the Fundamental Diagram of Road Traffic. **Transportation Research, Vol.1, pp.21-29.**
- Yousif, S.Y. (1993) Effect of Lane Changing on Traffic Operation for Dual Carriageway Roads with Road Works. **Thesis (PhD), University of Cardiff, Wales, United Kingdom.**
- Zarean, M. (1987) Development of a Simulation Model for Freeway Weaving Sections. **Dissertation (PhD), the Ohio State University, USA.**

Estimation of critical occupancy values for UK motorways from traffic loop detectors

Jalal Al-Obaedi & Saad Yousif, *University of Salford*

Abstract

Occupancy is the percent of time a traffic loop detector embedded in the road pavement is occupied by vehicles. This term is usually used as a substitution for the traffic density which is not feasible to obtain from detectors. One of the recent applications for the traffic occupancy is in calculating the timing for traffic signals on motorway entrances (Ramp Metering, RM). Most of the existing algorithms for RM assume that these devices will not operate until the traffic occupancy upstream or downstream from the merge area exceeds a specific value called “critical occupancy”. This paper focuses on estimating the critical occupancy using Motorway Incident Detection and Automatic Signalling (MIDAS) data. The data is taken from loop detectors located on three motorway sites in the UK. The results are compared with corresponding values as adopted by the Highways Agency for these sites to operate the ramp metering. The results show that the values which are currently used to operate the ramp metering devices in these sites are higher than those obtained from analysing the data. This will cause delays in the operation of the RM until the starting of traffic congestion which ultimately causes reduction in motorway capacity.

Keywords: Occupancy, loop detectors, ramp metering

1. Introduction and background

Occupancy is the percent of time a traffic loop detector embedded in the road pavement is occupied by vehicles. Unlike the well known traffic density, occupancy can easily be measured from traffic loop detectors that are located regularly around a motorway’s junction. Hall et. al (1986) concluded that time occupancy can describe traffic conditions (congested, uncongested or transitional) in the same way as traffic density could do. Figure 1 explains the flow-occupancy relationship using data taken from an upstream detector from the M6 J23 Motorway site. The figure explains how this relationship is similar to that for flow-density. The relationship between traffic density and occupancy based on data from 5 detectors on the M6 J23 is presented in Figure 2. The density is estimated by dividing the motorway flow by the average speed.

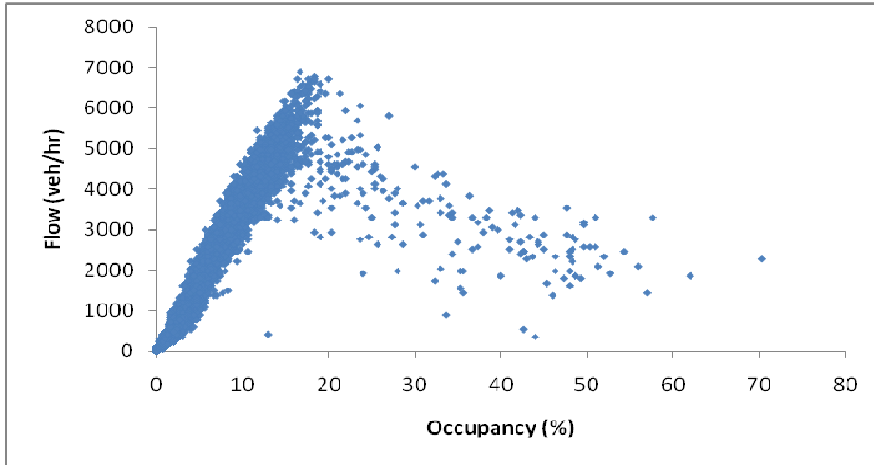

Figure (1) Flow-occupancy relationship bases on data from the M6 J23

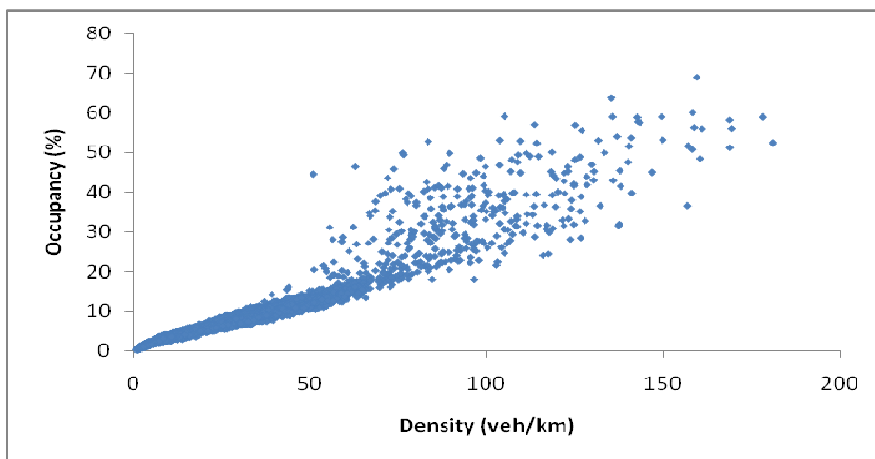

Figure (2) Occupancy-density relationship based on data from the M6 J23

The term “Critical occupancy” is extensively used to define the limit between normal and congested traffic situations. In almost, critical occupancy corresponds with the motorway capacity Smaragdis et al. (2004). Previous research suggests a range of values for critical occupancy. For example, Hall et al. (1986) based on data from Queen Elizabeth Way in Ontario found that critical occupancy lies between 19 and 21%. The Minnesota Department of Transportation used a value of 18% to separate congested and uncongested flow. Sarintorn (2007) concluded that critical occupancy for the Pacific Motorway in Australia ranged from 17-20%. Zhang and Levinson (2010) used time occupancy to indicate the occurrence of bottlenecks using data taken from loop detectors in the USA. When the

occupancy is less than 20%, traffic is regarded as not congested, when occupancy lies between 20 and 25% the traffic is regarded to be in the transitional phase while the traffic regarded to be in the congestion phase if the occupancy exceeds 25%.

2. Application of occupancy in ramp metering

Recently, traffic signal devices (ramp metering) have been installed on motorway entrances on a part-time basis to regulate the entering traffic in an attempt to reduce congestion. Previously, these devices worked on a fixed time plan where the traffic signal operated for specific periods with a set time. Now, most of existing methods for ramp metering are reactive. This means that the timing of the traffic signal changes based on the traffic conditions. In the later extension of ramp metering, time occupancy is applied in different ways. These are to judge the need to trigger the ramp metering devices, to calculate the required timing for traffic signal and finally to switch off the traffic signals after operating.

Currently, ALINEA (Papageorgiou et al., 1991, 1997) and Demand-Capacity algorithms (Masher et al., 1975) are the most applicable algorithms for ramp metering in the world. Both methods use occupancy in updating the traffic signal timing. ALINEA calculates the metering rate from equation 1 while Demand-Capacity uses equation 2.

$$r = r(c-1) + KR(Occ_d - Occ(c-1)) \quad \dots (1)$$

$$r = \begin{cases} Cap - flow_{min} & \text{if } (Occ < Occ_{crit}) \\ r_{min} & \text{else} \end{cases} \quad \dots(2)$$

Where:

r is the metering rate (veh/hr),

$r(c-1)$ metering rate during the last time interval (veh/hr),

KR is the regulator parameter (veh/hr),

Occ_d is the desired occupancy and usually equal to critical occupancy (Occ_{crit}),

$Occ(c-1)$ is the actual occupancy during the last time interval,

r_{min} is the minimum metering rate (veh/hr),

Cap is the capacity of the downstream merge section, and $flow_{in}$ is the upstream motorway flow.

It is worth mentioning that using inaccurate values for critical occupancy can lead to the improper applications for ramp metering and that will affect the ability of these devices in the alleviation of traffic congestion. In addition, using values lower than the actual to trigger the traffic signals will cause further delays for merging traffic.

The contribution this paper is to estimate the critical values for critical occupancy using data from loop detectors and to compare these values with such values currently used on ramp metering on the studied motorways of the UK.

3. Methodology

In this paper, Motorway Incident Detection and Automatic Signalling (MIDAS) data from upstream and downstream loop detectors from 4 motorway sites is used. These sites are M56 J2 (two lanes), M60 J2 (three lanes), M6 J23 (three lanes) and M6 J20 (four lanes). The data provided is taken over one minute for speed, flow and occupancy.

Two methods are used to estimate the critical occupancy. The first method is suggested by Hall et al. (1986) for finding the average occupancy for each given flow. Obviously, there are two values of occupancy for each value of flow (i.e. in normal and congested traffic). The method requires an assumed trial value for critical occupancy. The purpose of that is not to average occupancies from normal conditions with those from congested conditions. After doing some trials for critical occupancy, all values then should be compared graphically. The critical occupancy value is then selected based on the point which gives the maximum flow at normal traffic condition. To apply this method the occupancy are averaged for each flows within interval of +100 veh/hr. A simple computer program is written to speed up the computational process. This method also requires the removal of the transition points from congested to normal conditions from consideration.

The second method is to inspect the raw data for values of occupancy which separate then normal and congested situations. This method is known as “time series inspection method”. The method is mentioned by Hall et. al (1986) to explain the nature of changes in operations. However, they did not use

this approach in estimating the critical occupancy. According to this method, critical occupancy will be the transition value from normal to congested situations.

The results from these three methods are compared in this paper by existing values which are currently in use to trigger the ramp metering in some of the above referred sites.

4. Results and discussions

Before applying the average occupancy approach for each corresponding flow, the data is filtered to remove the transition cases from congested to normal traffic situations. Figures 3, 4, 5 and 6 show the possible shapes for flow-occupancy relationships for different trials of critical occupancy values using the approach of average occupancy at each specific flow for the M56 J2, M6 J23, M6 J20 and M60 J2, respectively. For the M56 J2, Figure 3 shows that the critical occupancy value lies between 25 and 26%. Lower values are not considered because these lower values give flows for congested regime that are equal or higher to those in a normal regime.

In the same way, and based on Figures 4-6, values of 23%, 22% and 20-21% are suggested for the M6 J23, M6 J20 and M60 J2, respectively:

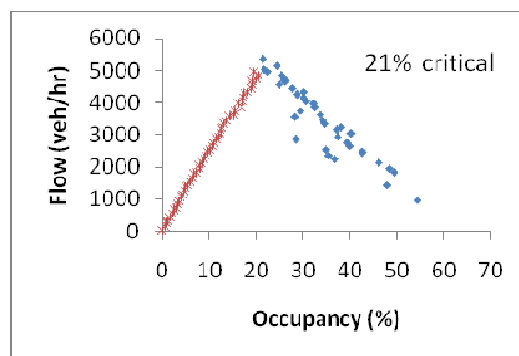
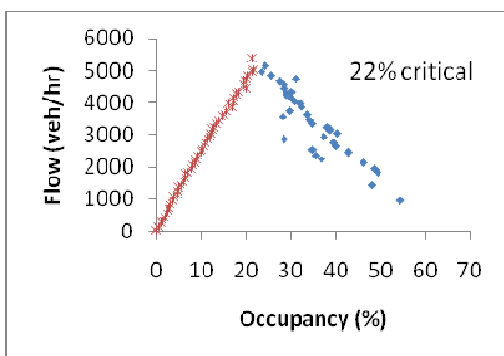

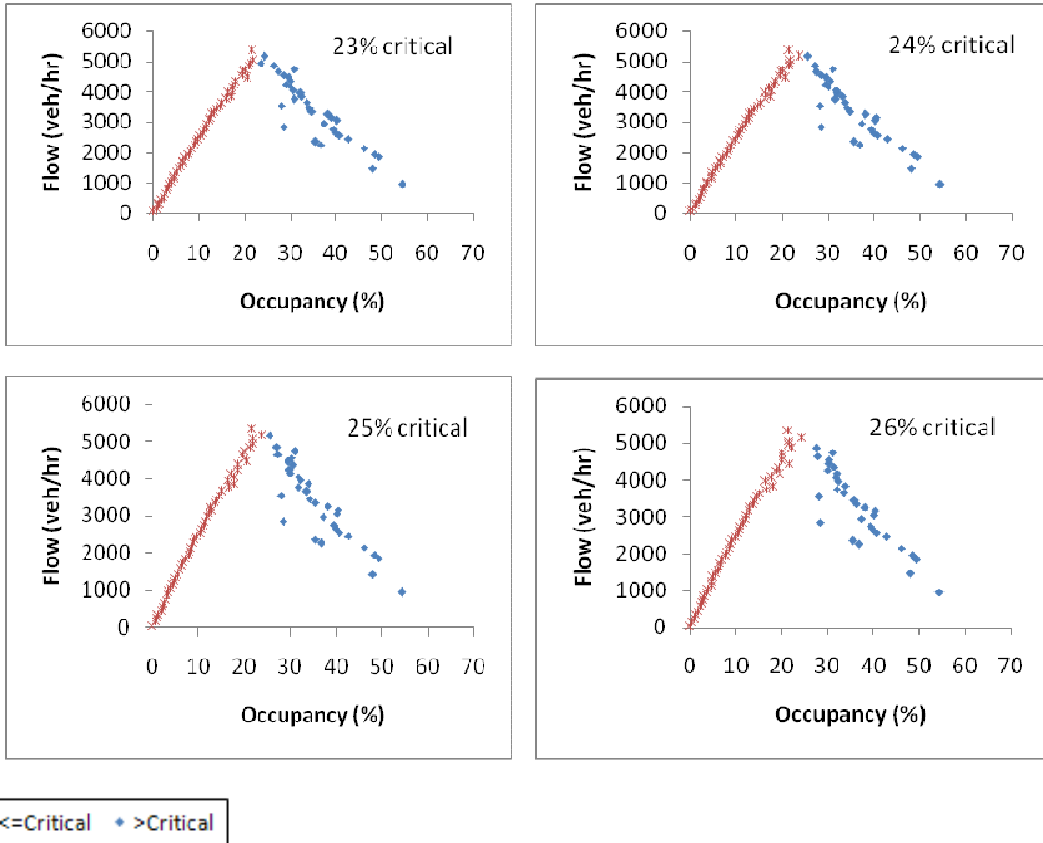

Figure (3) flow occupancy relationship for the M56 J2 downstream detector.

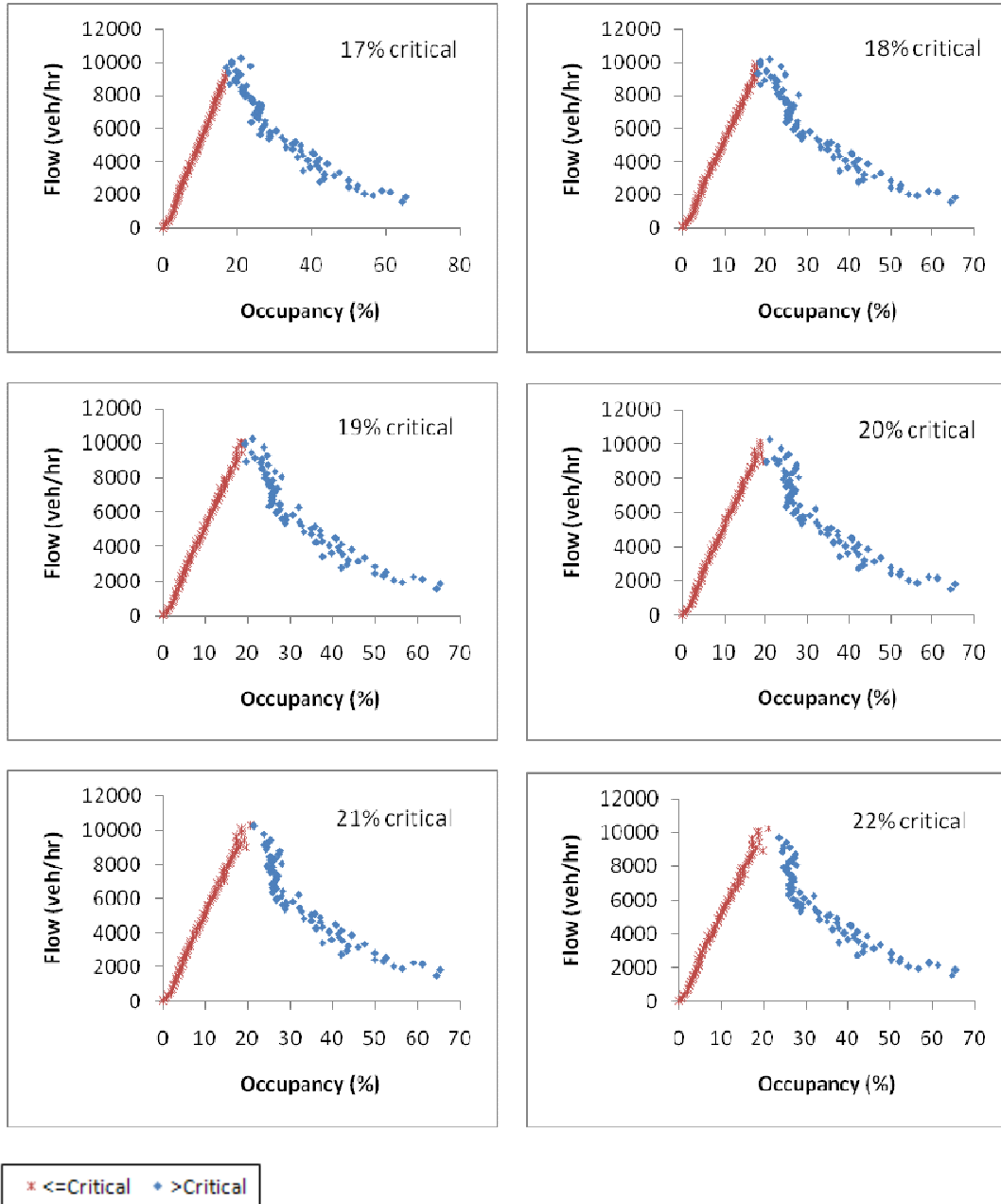

Figure (4) flow occupancy relationship for the M6 J20 downstream detector.

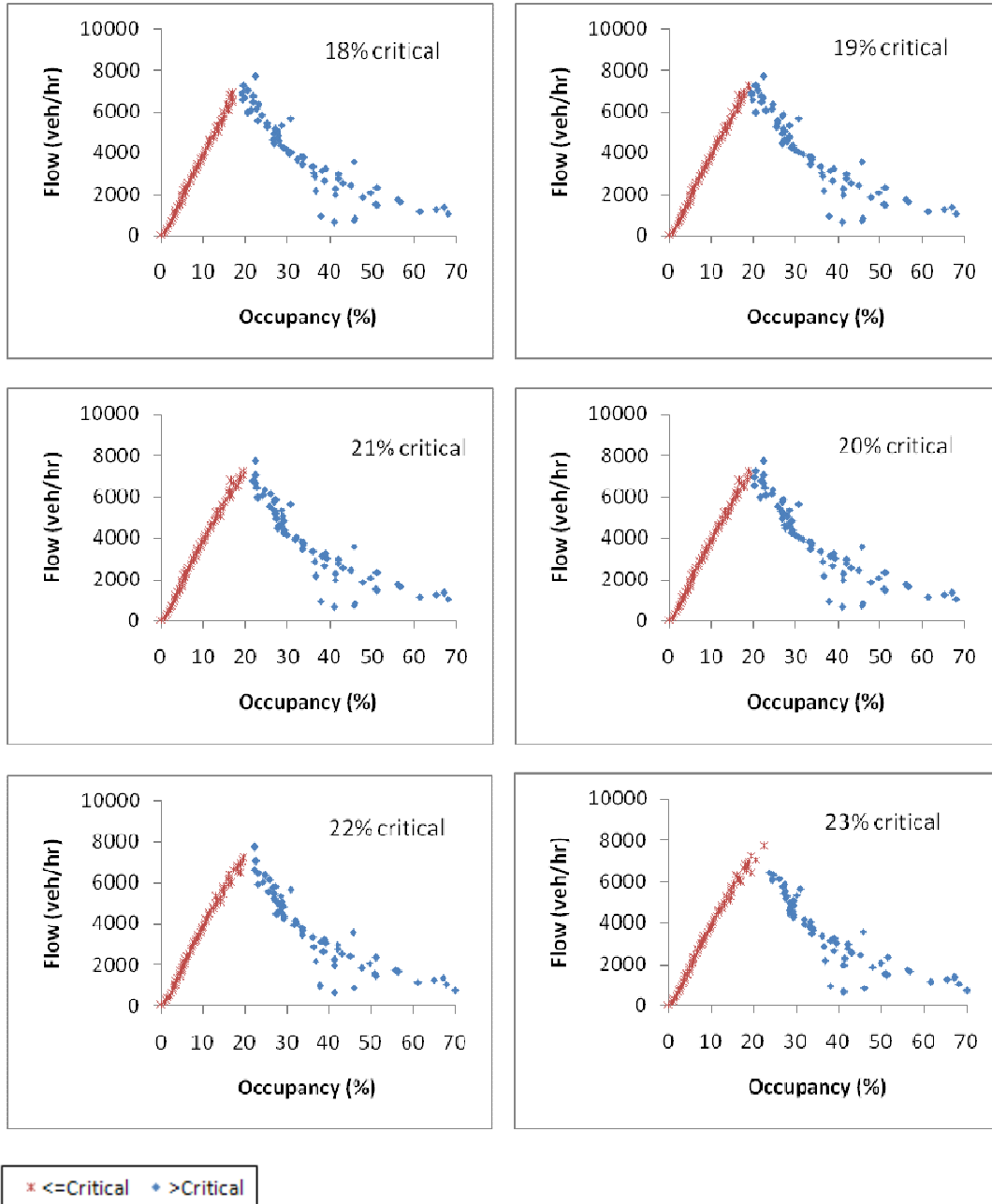

Figure (5) flow occupancy relationship for the M6 J23 downstream detector.

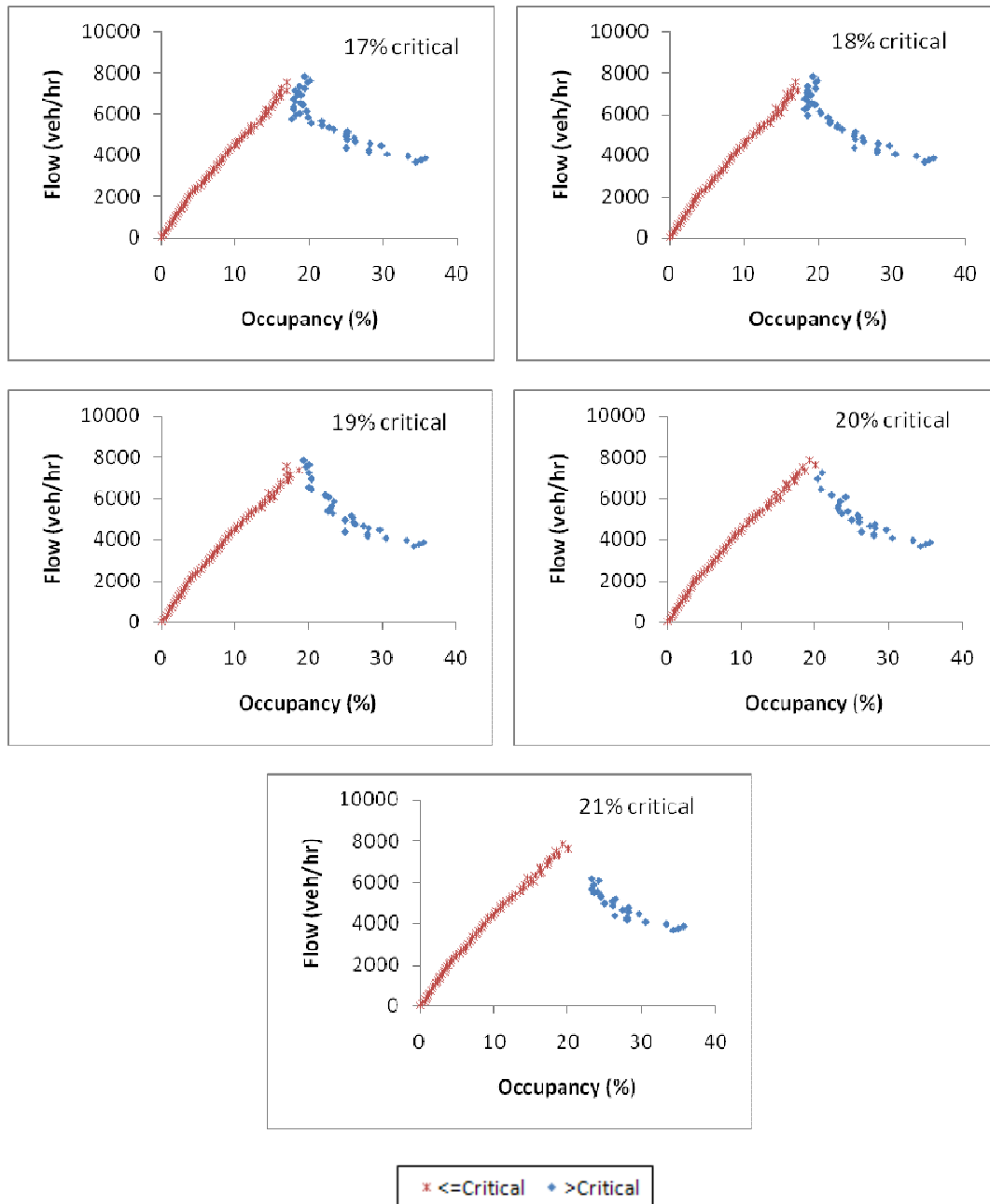

Figure (6) flow occupancy relationship for the M60 J2 downstream detector.

Figure 7 gives examples about critical occupancy values based on the time series inspection approach. It should be noted that only congested situations caused by merge traffic are considered (i.e. congested situations due to further downstream bottlenecks are not considered). While the results obtained from the first method (average occupancy) gave limited variation in critical occupancy between sites, the variation is more announced using the time series inspection method. This variation is also described in the work by Hall et al. (1986).

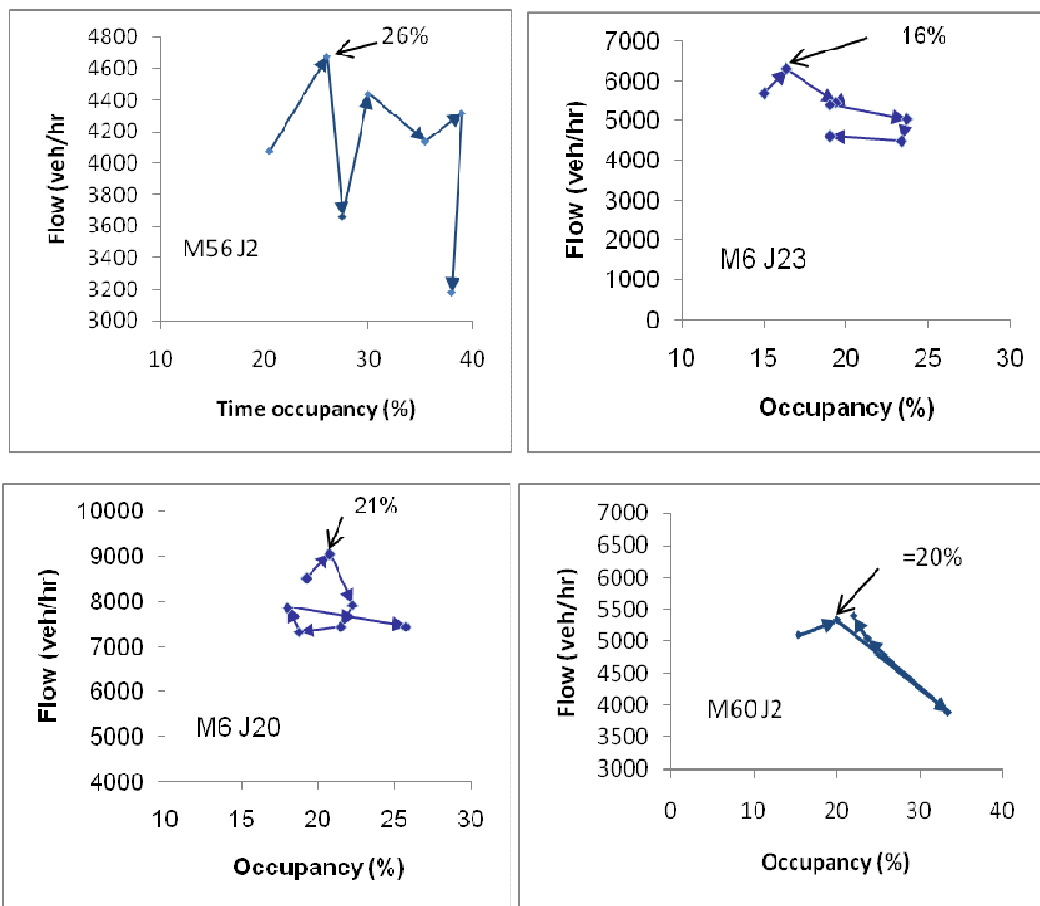

Figure (7) Critical occupancy values using time series inspection method

Table 1 compares the critical occupancy values obtained from the average occupancy approach with such critical values that are currently in use to trigger the ramp metering devices on the selected motorway sites. The value that is used to trigger the ramp metering in M56 J2 was not given due to a lack of data. The table shows that for the M6 J23 and M6 J20 sites, the values which are currently used to operate the ramp metering devices in these sites are higher than those obtained from analysing the data. This will

cause delays in the operation of the RM after the traffic congestion has started and that ultimately causes reduction in motorway throughput. For the M60 J2, the value used is much close to the estimated value.

Table 1 Estimated and Values in use for critical occupancy

Site	M6 J23	M6 J20	M60 J2
Estimated critical occupancy (%)	23	22	20-21
Value in use in RM (%)	28	25.5	19

5. Summary

This paper focuses on the estimation of critical occupancy using data taken from loop detectors. The data from four motorways junctions which are served by ramp metering devices in the UK are used. These motorways are M56 J2, M60 J2, M6 J23 and M6 J20. Two methods are used to find the critical occupancy. The first method is by finding the average occupancy for each corresponding flow. The second method is to follow-up the transitions from normal to congested situations. It is found that the variation between the results between the selected sites is more pronounced using the second method. The results are compared with corresponding values as adopted by the Highways Agency for these sites to operate the ramp metering. As a part of M60 J2, the results show that the values which are currently used to operate the ramp metering devices in these sites are higher than those obtained from analysing the data. This will cause delays in the operation of the RM until the starting of traffic congestion which ultimately causes reduction in motorway capacity.

6. References

- Hall, F. L., Allen, B. L. and Gunter, M. A., (1986). Empirical analyses of freeway flow-density relationships. *Transportation Research A*, Vol. 20A, No. 3 p.p. 197-210.
- Masher D.P., Ross D.W., Wong P.J., Tuan P.L., Zeidler H.M., and Petracek S., (1975), *Guidelines for Design and Operation of Ramp Control Systems*", Stanford Research Institute, Menid Park, CA.
- Minnesota Department of Transportation, (2000). MnDOT Traffic Management Center all detector report

Papageorgiou, M., Haj-Salem, H. and Blosseville, J-M. (1991). "ALINEA: a local feedback control law for on-ramp metering." *Transportation Research Record*, Volume (1320), p.p. 58-64.

Papageorgiou, M., Haj-Salem, and F. Middleham, (1997), *ALINEA local ramp metering: Summary of field results*. In *Transportation Research Record 1603*, TRB, National Research Council, Washington D.C., 1997, pp. 90-98.

Sarintorn, W. (2007) Development and comparative evaluation of ramp metering algorithms using microscopic traffic simulation. *Journal of Transportation*, Volume (7), Issue 5, p.p. 51-62.

Smaragdis, E., Papageorgiou, M. and Kosmatopoulos, E. (2004) A flow-maximizing adaptive local ramp metering strategy, *Transportation Research Part B: Methodological*, Volume (38), Issue 3, p.p. 251-270

Zhang, L. and Levinson, D. (2010) Ramp metering and freeway bottleneck capacity *Transportation Research Part A* 44 218–235.

The Effects of Residential Location on Total Person Trip Rates: An Empirical Study

Firas Asad, *School of Computing, Science and Engineering, University of Salford*

1. Introduction

Developing a robust trip generation model, for predicting the number of vehicular/person trips generated by a residential development, is still a vital task for both transportation planners and engineers. There are two key reasons for this; one of them is because trip generation is the first model in the travel forecasting process for the vast majority of orthodox urban transportation modelling systems (UTMSs). The second reason is because local planning agencies need the predicted number of trips that are likely to be generated from a proposed development to quantify the anticipated impacts of such development on the transport system infrastructure and performance.

Consequently, many researchers have been studying the factors that possibly affect the total number of the generated trips (trip ends). Site location as one of the residential land use descriptive characteristics, is one of the relevant factors to be studied. The objective of this paper is to investigate whether the location of a residential site affects its trip-making pattern and hence its traffic impacts as an attempt to attach a spatial dimension of study to the land use-trip generation relationship.

The Trip Rate Information Computer System (Trics-ver.2009a), being one of the UK and Ireland's industry standard trip generation database, is interrogated in this study. It is used to derive the likely mean person and vehicle trip ends for residential sites with six different location types and for, where possible, six modes of travel. The statistical methodology ANOVA (Analysis of Variance) using SPSS (ver.17, 2008) software is employed to examine whether there are any statistically significant differences among the trip rates means of Trics main location groups for each travel mode separately.

2. Trics Database

Trics was founded and is owned by the Trics Consortium, which consists of 6 county councils (West Sussex, East Sussex, Surrey, Kent, Dorset, and Hampshire). It is the national standard for trip generation analysis, containing about 6,000 directional transport surveys at more than 100 types of land uses in the UK and Ireland (Trics website, 2010).

At the start of the trip rate calculation process, after selecting the proper land use category and subcategory, Trics asks the user, through a number of windows with user-friendly interface, to provide the system with a series of initial, main, secondary, and optional parameters. By specifying these parameters users can create their representative sample of sites. In the initial parameters window, the user is required to choose between vehicle-based and multi-modal trip rate calculation options. In the multi-modal option, trip rates and/or the total number of arrival, departure and total trips (both direction) can be computed for travel modes other than total vehicles like, for instance, pedestrians, cyclists, PTUs, and total people.

In the next stage, the main parameter window, the primary trip rate parameter like number of dwellings, total bedrooms or site area should be firstly chosen followed by the desired week days and finally the main and secondary site location types. After that, in the secondary stage, desired sites and survey days should be determined. Finally, further fine-tuning for the sites may be done by optional parameters including population, car ownership and access to a travel plan.

Trics, in line with the planning policy statement 6 (PPS6, 2005), assigns main and, where applicable, sub-location definitions as a descriptive characteristic for each development site. The main location categories are basically as a proxy measure of how far is the site from the central core area of the town/city. The availability of public amenities is also a major determinant in location definition. In Trics 2009(a), being interrogated in this study, there are six main location categories; Town centre TC, Edge of town centre ETC, Neighbourhood centre NC (Local centre), Suburban area SA (Out of centre), Edge of town ET, and Free standing FS (Out of town). For more information and definitions, interested readers are referred to the Trics 2009(a) online help. Taking into account the basic requirement for a statistically adequate sample size, only the main six location types are considered in this analysis. On the other hand, the total vehicle counts in addition to five of the multi-modal trip rate counts are included in the statistical analysis. These five multi-modal counts are: total people, pedestrians, vehicle occupancy, PTUs, and motor cars.

There are 13 residential land use subcategories (sub land uses) in Trics (2009a); only seven of them were chosen to be interrogated in this study. These seven are; Houses Privately Owned (HPO), Houses for Rent (HFR), Flats Privately Owned (FPO), Flats for Rent (FFR), Mixed Private Housing (MPH), Mixed Non-Private Housing (MNPH), and Mixed Private/Non Private Housing (MPNPH).

A full definition of these residential developments is available in the Trics 2009 Online Help File. Other subcategories were excluded either for lack of an adequate number of sites (in this study a threshold of more than 3 sites is adopted), or because of the inconsistency in the trip generation calculation parameter.

For all the seven selected subcategories, the number of dwelling units is adopted as a unit of analysis in calculating the vehicle and person weekday trip rates. The Guidance on Transport Assessment (2007) reports that for residential developments the peak periods predominantly occur on weekdays, hence surveys selected in this study were based on a 12hr. (7.00-19.00) weekday analysis period.

In line with Trics recommendations (Trics Basic Tutorial, 2005), only the most recent surveys were chosen to avoid any possible bias towards the multiple survey sites. Furthermore, in order to keep the subcategory datasets as eligible as possible for statistical analysis, no further filtering has been applied by Trics optional parameters. In Table 1, each cell shows the available number of multi-modal counts sites in Trics 2009(a) for each specific residential land use and location type. Unfortunately, this pilot survey evidently reveals that most of these cells are ineligible for statistical analysis according to this study threshold (more than 3 sites).

Table 1: Trics 2009(a) multi-modal counts sites cross classified by both residential land use and location types

Land use / Location Types	Town centre	Edge of town	Neighbour hood	Suburban area	Edge of town	Free Standing
A. Houses privately owned	0*	6	2*	30	28	0*
B. Houses for rent	0*	2*	0*	5	1*	0*
C. Flats privately owned	3*	10	0*	10	0*	0*
D. Flats for rent	0*	7	0*	9	4	0*
K. Mixed private housing	1*	2*	1*	13	3*	1*
L. Mixed non private housing	0*	2*	0*	1	0*	0*
Mixed private/non private housing	0*	0*	0*	8	6	0*

* Not sufficient for statistical analysis.

To avoid this, a proposed regrouping of the seven Trics 2009(a) residential subcategories, produced by Asad and Henson (2010) has been adopted. Based on a statistically grounded methodology and the category analysis method concepts, Asad and Henson (2010) showed that these seven residential subcategories are not significantly mutually exclusive.

As a consequence, a new grouping consisting of two main housing subcategories has been produced, namely; Houses-like travel behaviour (HLTB) and Flats-like travel behaviour (FLTB). The first housing subcategory, HLTB, contains four of the seven original Trics residential subcategories; Houses-privately owned, Houses for rent, Mixed non-private housing, and Mixed private/non-private housing. In contrast, Flats-like TB housing group contains the remaining three; Flats privately owned, Flats for rent, and Mixed private housing.

3. Site Location

The Trics good practice guide (2009, p.4) pointed out that site location type is one of the vital data fields when seeking site selection compatibility. Six main location categories are listed in Trics 2009a, and all of them, where possible, are considered here. The guide further stated that development sites located in a town centre will experience a modal split different from another site in rural areas when there is a considerable variation in the acceptable level of local public transport accessibility.

Many researchers have highlighted the issue of how the travel behaviour of a specific land use may be affected by its location type. Hurst (1970) stated that land use location, relative to the central business district (CBD/Non CBD), is a principal variable in the functional relationship between a non-residential land use and urban travel volume. Baumgaertner (1985) for example, found that trip generation rates for movie theatre in urban areas are quite different from those in suburbs. Three modes of travel were included in the study; passenger vehicles, pedestrian and rail/bus.

Szplett and Kieck (1995), depending on household travel surveys from two cities, demonstrated that household location with respect to the city centre has a clear impact on the number of generated vehicle trips. In addition, they revealed that downtown residents generate vehicle trips more than those living in suburban environments. Boarnet, et al. (2003) in their statistical research found out that non-work trip frequency, in the developed ordered probit model, significantly depends on a set of sociodemographic and land use variables. Residence location relative to the CBD was found to be one of them. Rhee (2003) emphasised that in constructing the cross classification table in the category analysis method, households are categorised according to a set of attributes such that trip production characteristics within each category are similar. Household location is one of these attributes employed for stratification.

Three recent relevant studies have been found during reviewing previous studies. O’Cinneide and Grealay (2008) studied the likely primary factors that would quantify the traffic volume generated from residential developments in Cork, Ireland. The measured morning peak hour (8.00-9.00) car trip rates were

compared with Trics equivalent rates. It was revealed that development location mainly influences the morning peak traffic generation frequency, type of occupant, and car ownership level. Three location types were included; inner city, suburbs, and rural areas. The study claimed that car trip rates for inner city/town development are, in general, lower than those rates in suburbs or rural areas. However, no statistical evidence was employed to show how significant is the location effect on the residential traffic generation.

Maclaine (2007) based on Trics 2007(a) site characteristics and count data and the correlation statistical technique results, showed that no significant correlation was found between the multi-modal count data and the Trics 2007 optional parameter; location. Therefore, the study stressed that refining the sample according to the main location parameter is not recommended. It is worthwhile noting that the Pearson correlation coefficient (r) was used as a parametric test, although no statistical evidence was presented to show both the normality of the correlated variables and their variance homogeneity. Furthermore, the Pearson correlation coefficient was computed for two variables; one is continuous (trip rate) while the other is categorical (location). Nevertheless, the study failed to submit an illustrative example to demonstrate how that was done.

Broadstock (2008, 2009), using Trics 2004(b) as the main database, researched the possible effect of land zone placement, in line with spatial planning policy, on passenger car trip making behaviour in residential areas. Depending on a semi-parametric regression technique and bootstrap algorithm, the study concluded that geographical features such as land zone placement marginally determine residential car trip generation rates. Broadstock (2009, p.19) claimed that “there are no individually significant land zone variables, yet they represent a statistically relevant feature of the final preferred model”. Hence, no powerful proof has been produced on the proposed functional relationship between land zone placement and travel behaviour.

Two key points should be highlighted in both of Broadstock’s studies; the first is the data constraint in Trics during the selected period of study (1987-2002) (Broadstock, 2008, p.145). The second is the use of a semi-parametric technique instead of a robust parametric one due to the issues of small sample size and variance heterogeneity (Broadstock, 2008, p.2). Finally, the study has failed to properly distinguish between the 14 Trics 2004(a) residential sub land uses when analyzing land zone impacts on travel behaviour. In particular, the study considered all the 14 sub land uses as one single residential group neglecting the extra effects of different types on trip rate characteristics (Broadstock, 2008, p.158).

4. Study Methodology

For obvious statistical reasons it is highly recommended when studying the probable effect of a specific factor (independent) on the behaviour of a certain variable (dependent) to exclude the possible effects of other factors that may influence the dependent variable behaviour. For applying this scenario here, it is supposed to isolate the impacts of other socio-economic and development type factors when studying the effects of housing development location type on its trip making patterns.

However, the Trics 2009(a) database in its current depth and breadth of records makes it statistically impractical to filter data like that. According to the vast majority of trip generation literature, the type of development has a significant effect on the trips generated, consequently, only this factor is considered in this study. Furthermore, the scientifically grounded new housing groupings suggested by Asad and Henson (2010) for Trics 2009(a) residential land uses is adopted; Houses-like TB and Flats-like TB.

It is useful to recall that the effect of the six housing location types on the number of trips generated was examined separately for each of the two new housing groupings. As mentioned previously, six types of travel modes have been adopted; total vehicles, motor cars, PTUs, pedestrian, vehicle occupancy, and total people. Total vehicle counts were extracted from the vehicle trip rate option in the Trics 2009(a) trip rate calculation initial parameter window. In contrast, the other travel modes count data were calculated using the multi-modal trip rate option. For each mode of travel mentioned above, the statistical procedure one-way ANOVA has been employed to test whether there is a significant difference between the trip rate means (dependent variable) of the six selected location types. This is done for each housing group separately.

Using SPSS (ver.17) the Least Significant Difference (LSD) method is employed to investigate the potential differences between sample group means (with a null hypothesis H_0 : there is no significant difference) at 5% level of significance (LOS). Moreover, using the ANOVA post – hoc analysis technique, multiple comparisons could be performed to discover which specific group mean (mean of a specific trip rate location category) may significantly differ from others and by how much (George and Mallery, 2009).

Being one of the robust parametric statistical tests, ANOVA depends on restrictive main conditions, like normality and variance homogeneity. The data in the groups being tested should be independent and drawn from a population that is normally distributed and these groups should have variances not substantially different from each other (Keller, 2005). Based on Shapiro-Wilk (S-W) and Kolmogorov-Smirnov (K-S) normality tests embedded in SPSS, it has been found that some of location groups have data displaying the non-normality problem.

This problem has been solved by applying a logarithmic transformation of type ($y = \ln(x)$) for these groups' observations. This mathematical solution has been suggested and supported by many researchers (for example see Bland and Altman (1996) and Osborne (2002)). On the other hand, Levene's test is used to examine whether the between-groups variances are substantially heterogeneous (Heteroskedasticity). Hayter (2007) emphasised that both of these conditions could be considered satisfied unless they have been violated remarkably, i.e., either the data are obviously not normally distributed or there is a significant difference between the variances of the levels (location categories) of the factor (trip rate) being analysed.

5. Data Analysis Results and Discussion

The limited count data for modes of travel at some location categories is the reason behind excluding some statistics from the analysis. For instance, there is no data for HLTB housing in town centres, whereas, both neighbourhood centre and free standing locations were mostly excluded for the shortage of a statistically efficient sample size. The trip rate figures are the total (arrivals and departures) 12hr. (7:00-19:00) expected trips per each dwelling unit. In the following subsections the analysis results of the effect of site location on trip making pattern will be shown and discussed for each type of traffic counts. The level of significance (LOS) is 0.05 (5%) for all the inferential statistical analysis unless stated otherwise.

a. Total vehicles

This count includes all vehicles entering and exiting a site at any access point excluding cyclists. For HLTB housing, Table 2 shows the SPSS normality tests output for the total vehicles trip rate (VehTR) dependent variable. It is clear that approximately all the location groups have data that are normally distributed at 5% LOS according to Shapiro-Wilk test. Although, ET location group are significantly different from normality using S-W test, however, it does not show significant deviation from normality at 0.10 LOS using K-S test (Sig.= 0.02). As a result, no more concerns were devoted to the normality assumption of the ANOVA model and therefore a logarithmic transformation was not adopted in this case.

Table 2. Tests of Normality results for HLTB housing.

Location Type	Sig. (P-value)	
	Kolmogorov-Smirnov ^a	Shapiro-Wilk
VehTR Edge of Town Centre ETC	.103	.166
Neighbourhood Centre NC (PPS Local Centre)	.200*	.444
Suburban Area (PPS Out of Centre)	.200*	.633
Edge of Town	.022	.002
Free Standing (PPS Out of Town)		.299

a. Lilliefors Significance Correction

Table 3 shows the output results of the Levene’s test for the homogeneity of variances (Homoskedasticity). The statistics do not prove any distinct variation (P-value = 0.237).

Table 3. Test of Homogeneity of Variances

Levene Statistic	df1	df2	Sig.(P-value)
1.394	4	249	.237

The results of the ANOVA model are found to be significant with P-value (Sig.) equal to 0.008. This means there is at least one location group with trip rate mean significantly deviate from others. Post-hoc tests using the LSD method may now be carried out. Table 4 presents the HLTB housing group multiple comparisons. The statistical analysis results (see table 4) reveal that edge of town ET trip rate is significantly larger than vehicle trip rate in both edge of town centre ETC and neighbourhood centre NC main location categories (P-values equal to 0.015 and 0.002 respectively).

Table 4. Multiple Comparisons results using LSD method.

(I) LocCode	(J) LocCode	Mean Difference (I-J)	Std. Error	Sig.(P-value)
Edge of Town Centre	Neighbourhood Centre	-.129508	.487426	.791
	Suburban Area	-.675883	.445967	.131
	Edge of Town	-1.055186*	.432593	.015
	Free Standing	-.582964	.870230	.504
Neighbourhood Centre	Edge of Town Centre	.129508	.487426	.791
	Suburban Area	-.546375	.316059	.085
	Edge of Town	-.925678*	.296890	.002
	Free Standing	-.453456	.811361	.577
Suburban Area	Edge of Town Centre	.675883	.445967	.131
	Neighbourhood Centre	.546375	.316059	.085
	Edge of Town	-.379303	.222365	.089
	Free Standing	.092919	.787152	.906
Edge of Town	Edge of Town Centre	1.055186*	.432593	.015
	Neighbourhood Centre	.925678*	.296890	.002
	Suburban Area	.379303	.222365	.089
	Free Standing	.472222	.779653	.545
Free Standing	Edge of Town Centre	.582964	.870230	.504
	Neighbourhood Centre	.453456	.811361	.577
	Suburban Area	-.092919	.787152	.906
	Edge of Town	-.472222	.779653	.545

*. The mean difference is significant at the 0.05 level.

Table 4 presents the full SPSS output for this case. However, to avoid excessive length, SPSS results for the remaining comparisons will be limited to summary results rather than full tabulations.

For FLTB, Similarly, ANOVA primary conditions (normality and homoskedasticity) should be at first satisfied before performing the multiple comparisons. Natural log transformation was done for data since there was significant deviation from the normality for some of them. The post-hoc tests results show that town centre TC trip rate is substantially lower than other locations' rates. Furthermore, no significant distinctions in trip rates are noticed between edge of town ET, suburban area SA, and neighbourhood centre NC locations. However, it seems that people in ET locations use vehicles more than those living near TC. Fig. 1 shows that, in general, there is an increase in the total generated vehicles with the increase of site distance from the CBD.

b. Total People

According to Trics 2009(a) help file, total people includes the sum of cyclists, private vehicle occupants, pedestrians, and PTUs, i.e. all the person trips to and from the site. Fig. 2 shows the variation in the person trip rate among several location categories for both Houses-like TB and Flats-like TB . A natural log transformation was used for this data.

For HLTB housing, SPSS results show that mean trip rate in suburban areas is significantly larger than the one in edge of town centre location with P-value (Sig.) equal to 0.039; while for FLTB housing no significant difference in trip rate was found. It is reasonable to conclude here, that since there is no significant change in the total person trips, the reduction in vehicle trips noticed previously in town centre (Fig. 1) should be compensated by using other modes of travel like walking and public transport. Furthermore, Fig. 2 (as well as Fig.1) gives a graphical support to the results revealed by Asad and Henson (2010) and adopted in this study that HLTB housing presents significantly different results compared to FLTB.

c. Motor car

This count contains all cars including light vans and three wheeled cars. For HLTB housing, ANOVA results indicate that there is no significant difference in travel behaviour between people who live in ET and SA locations (Sig.= 0.932). In the same way, the analyses confirm that those live near town centres (ETC locations) use motor cars significantly less than others living in suburbs and edge of town (Sig. equal to 0.016 each). This point is generally supported by O’Cinneide and Grealy (2008).

On the other hand, households located in FLTB housing show noteworthy similarity in their travel behaviour (general ANOVA model P-value is 0.625) Nevertheless, both TC and ETC locations still trivially have trip rates lower than other locations. Data was transformed using natural logs.

1000 dwelling units development which generate about 1 PTU per a day. This modification was done just for TC locations in FLTB housing since it contained only 4 sites with two of them having zero values.

For HLTB, SPSS outputs make it obvious that there is only slight difference in trip generation rates within ETC, SA, and ET, with a P-value for the general ANOVA model equal to 0.237. Fig. 4, however, shows that public transport trips are relatively not as common in ET as in other locations. Nonetheless, it is not easy to conclude whether this behaviour is because of the lack of good public transport provision/services in ET or due to the high dependency on passenger cars.

In contrast, for the FLTB housing category, the results prove that town/city centre residents predominantly travel by public transport less than those living in other locations. That is probably because most of the outdoor frequently daily activities are, reasonably, within walking distance from their dwelling units; therefore, many people would probably prefer walking or using bikes.

e. Pedestrians

The multiple comparison tests, using logarithmic transformations, reveal that, for HLTB housing, the number of pedestrians near town centre (ETC) and in SA locations are higher than those in edge of town (ET). This difference is distinct between SA and ET (Sig. = 0.008). Furthermore, pedestrian trips frequency in ETC and SA are not clearly different.

In a similar way, for FLTB housing, the tests prove that pedestrian trip rates in town centres is substantially higher than in suburban environments with p-value almost equal to 0.05. No significant variations in trip rates were noticed among the other site locations shown in Fig 5. In light of this, it is logical to point out that people living in downtowns/city centres would prefer to accomplish their travel needs by walking rather than those living far from town/city centres.

That is might be because the number of public amenities that could accessed on foot in urban areas are more than those in rural areas.

f. Vehicle Occupancy

This trip count mainly includes all occupants of cars, motorcycles, light good vehicles, and other good vehicles. For HLTB, SPSS outputs indicate that the general ANOVA model is significant with a p-value equal to 0.042. Vehicle occupants in ETC are substantially smaller than those in suburbs (Sig. = 0.016) and edge of towns/cities (Sig.= 0.018). No difference in trip rate was proved between the last two locations.

For FLTB, as above, occupants trip frequency in the suburban centres does not considerably diverge from those in ET locations (sig.= 0.889). Nonetheless, the near centre locations ETC have lower trip rate than sites located far away from the centre with P-value early equal to 0.05. A general look to Fig. 6 makes the impression that people living out of city/town centre would prefer to share vehicles more than those who live in the vicinity of it. On the other hand, no significant discrepancy in PTUs trip rate was noticed for ETC, SA, and ET locations.

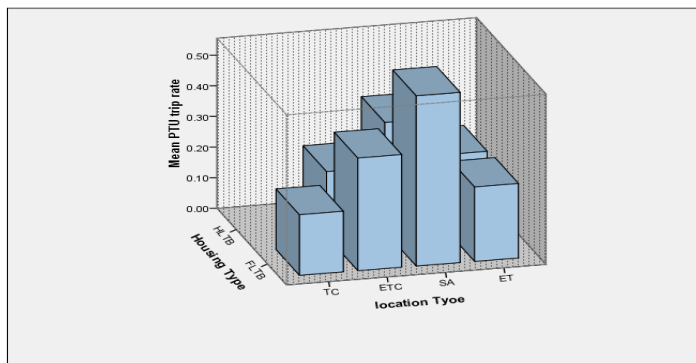

Fig. 4: Mean total public transport users trip rate variation according to the Trics2009a by location and housing types.

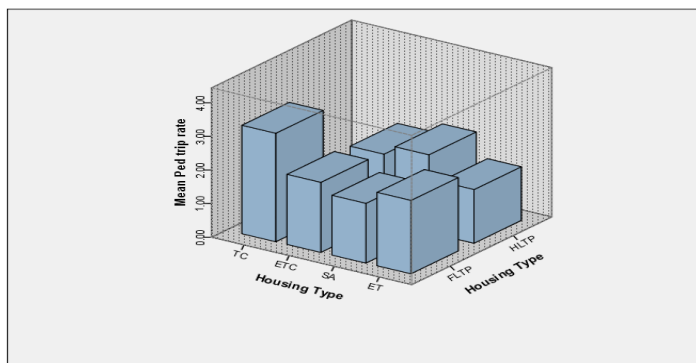

Fig. 5: Mean pedestrian trip rate variation according to the Trics2009a by location and housing types.

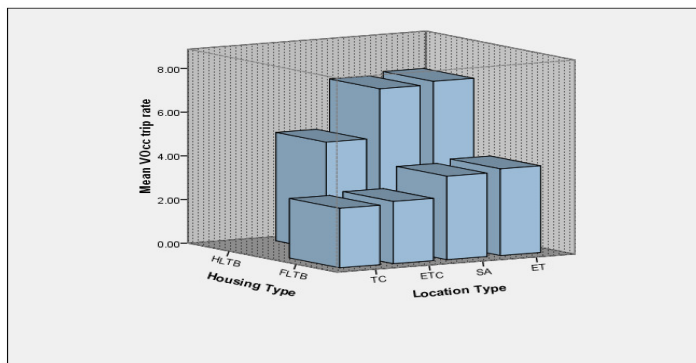

Fig. 6: Mean total vehicle occupants trip rate variation according to the Trics2009a by location and housing types.

6. Summary

To summarise, the statistical analysis and results presented here indicate that the number of trips generated in one location category may be considerably dissimilar from those generated in others, even if both them have the same residential land use subcategory. Hence, transportation planners concerned with residential travel demand forecasting are now advised to check the compatibility of their site representation sample in terms of location type in addition to the land use type.

Having mentioned that, Table 5 represents a general recommended guidance for site location compatibility. Allowing for borderline cases and data restrictions, the author counsels this table as a guidance rather than strict threshold. It is worthwhile mentioning that the Trics good practice guide (2009) suggests a table relatively similar, but without presenting any supporting statistical justification.

Table 5: Guidance compatibility table for Trics 2009 main site locations.

Main Location Type	TC	ETC	NC	SA	ET
Town centre TC	NSD	MD	SD	SD	SD
Edge of town centre ETC	MD	NSD	NSD	MD	MD
Neighbourhood centre NC	SD	NSD	NSD	NSD	MD
Suburban area SA	SD	MD	NSD	NSD	NSD
Edge of town ET	SD	MD	MD	NSD	NSD

SD: Significant Difference, MD: Marginal Difference, NSD: No Significant Difference.

7. Conclusions

Based on the statistical analysis conducted, the following conclusions arise:

1. The location of housing developments has a considerable effect on their residents' travel behaviour. Hence transport impacts of a proposed development on the transport system infrastructure and performance will vary from site to site according to their location type.
2. In general, residential developments located in/near town/city centres are display different characteristics from those located in/beyond the edge of town. For example, the town centre total vehicle trip rate is substantially lower than other locations' rates and the town centre residents predominantly travel by public transport less than those living in other locations.
3. The trip characteristics of Edge of Town Centre locations are relatively similar to those in Neighbourhood centres. Similarly, no significant difference was found between the trip

characteristics of Suburban and Edge of Town locations. Hence, better groupings of the location parameter in Trics should be investigated. Table 5, shows a proposal based on scientifically-grounded analysis.

8. References

- Asad, F.H., & Henson, R.R., (in press) Residential trip demand forecasting: A regression-based approach using Trics data. Unpublished paper.
- Baumgaertner, W.E., 1985. Movie theatre trip generation rates. *ITE journal*. 55(6), pp 44-49.
- Bland, J.M. & Altman, D.G., 1996. The use of transformation when comparing two means. *British Medical Journal* 312, p.1153.
- Boarnet, M.G., Nesamani, K.S. & Smith, S., 2003. Comparing the influence of land use on nonwork trip generation and vehicle distance travelled: An analysis using travel diary data. Paper prepared for the 83rd annual meeting of the transportation research board: Washington.
- Broadstock, D.C., 2008. *Traffic demand and land-use in the UK: an econometric analysis using the TRICS database*. Ph. D. University of Surrey.
- Communities and Local Government/Department for Transport, 2007. *Guidance on Transport Assessment*. London: The Stationery Office (TSO).
- George, D. & Mallery, P., 2009. *SPSS for windows step by step a simple guide and reference*. 10thed. USA: Pearson Education, Inc.
- Hayter, A.H., 2007. *Probability and statistics for engineers and scientists*. 3rd ed. Canada: Thomson Corporation.
- Hurst, M.E., 1970. An approach to the study of non-residential land use traffic generation. *Annals of the association of American geographers*, 60(1), pp. 153-173.
- JMP Consulting, 2005. *Trics Basic Tutorial 2005*.
- JMP Consulting, 2009. *Trics Good Practice Guide 2009*.
- Keller, G., 2005. *Statistics for management and economics*, seventh ed. Thomson Brooks/cole, USA.
- Maclaine, C.D., 2007. *Predicting trips generated by residential developments: an examination of two methods: linear regression and category analysis*. M. Sc. University of Salford.
- Osborne, J.W., 2002. Notes on the use of data transformations. *Journal of Practical Assessment, Research & Evaluation*, 8 (6). Retrieved May 11, 2010 from <http://PAREonline.net/getvn.asp?v=8&n=6>.

O’Cinneide,D. & Greal,R., 2008. Vehicle trip generation from retail, office and residential developments. In: Leeuwenhorst Conference Centre, European Transport Conference. The Netherlands, 06/10/2008 – 08/10/2008. Association for European transport and contributors.

Rhee, J., 2003. Improvement of trip generation forecast with category analysis in Seoul metropolitan area. *Proceeding of the Eastern Asia Society for Transportation Studies*, vol.4, pp. 818-831.

Szplett, D. & Kieck, L.T., 1995. Variations of trip generation and trip distance within the urban area. *Institute of transportation engineers*, 65th annual meeting, pp422- 426.

Trics 2009(a) v.6.3.1, Online Help file.

Trics, 2010. What is Trics? < <http://www.trics.org.uk/about.aspx>> (accessed 05.06.10).

Factors affecting the excellence of service quality at Syrian Public Banks (Case study: Commercial Bank of Syria and Real Estate Bank) Methodological Perspective

Dima Al-Sayeed Assad, *Salford Business School, University of Salford*

Abstract

According to the World Bank Report the market share of Syrian Public Banks have been shrunk from 86 % to 55% against the private banks at 2006 (World Bank Report, 2008). Ten Private banks have penetrated the Syrian Market during the current decade. It was noticeable that there is a big gap between the current offered performance of Syrian Public Banks and those required, now and in the medium-term, by customers, as measured by competitors and thresholds of the European Mediterranean partnership. In other words, poor service quality and inability to compete efficiently in the extensive expected competition become the main problem for those banks. The aim of this research is to investigate the factors affecting the excellence of service quality at Syrian Public banks.

Interpretivism philosophy will be followed. Inductive and deductive approaches will be applied. Two case studies will be investigated (Commercial Public Bank, and Real Estate Bank). Semi structure interviews with the three levels of management of both banks will be the main method for data collection. This paper will focus on methodological issues.

Keywords

Excellence, service quality, Syrian Public banks, Research Design and Methodology

1. Introduction

During the last two decades the banking industry has faced real challenges related to the deregulation and rapid innovative changes such as new financial products, new price strategies and new automated services. Macdonald (1995) demonstrates that initiatives have been easily copied by the competitors. Customers had struggled in differentiating the accumulated competitive offerings. However, banks ultimately had recognised that the best competitive policy which never fades is the excellent service quality. Banks become more conscious that delivering excellent service quality to customers is critical

factor for success and survival in today's global and competitive banking environment (Bisignano, 1992; Macdonald, 1995; Kim and Kleiner, 1996;

Lewis and Pescetto, 1996; Wang et al., 2003). Similarly, Syrian Public banks have witnessed many changes in their competitive environment which identify the real need to achieve the excellence.

2. The need for Excellence at Syrian Public banks

2.1. The Extensive Necessity to Improve Service Quality

There are different factors forcing the Syrian public banks to improve the level of service quality and achieve the excellence:

I. External Expected Competition

- **The Syrian Euro-Mediterranean Partnership**

Syria is one of the Mediterranean Countries with its strategic geographic position on the east coast of the Mediterranean Sea. On 14 December 2008 the agreement has been signed initially between Syria and EU countries. At the same time negotiation started between the Mediterranean countries with the aim of establishing similar free trade (Habeb, 2002). The third Part of the agreement is entitled the liberalization of service. Linked to the financial services, the Syrian Government monopolizes the insurance services and the stock markets. Banks are open according to the Law /28/ of 2001. Credit cards' services were opened to joint ventures with national banks. In this context, Syrian public banks have to be ready to penetrate the international market efficiently and strongly by achieving the excellent service quality.

II. Internal Present Competition

Responding to the requirement of joining the Euro-Mediterranean Partnership, Syrian Government issued the Private Banking Act No.28 of 2001 which allows foreign banks to penetrate the Syrian financial sectors after four decades of monopolising this market by national banks. At 2008, there were four Lebanese banks and two Jordanian banks starting their operations at the Syrian market. These banks are mainly subsidiaries of regional banks although majority ownership is held by Syrian investors. In 2005, urged by the leading two years of success within Syria's promising private banking sector, Syrian Government legalized the Decree No. 35, allowing for the establishment of Islamic banks. Four Islamic banks have been established quickly under the new legislation. According to IMF report (2008) private banks appear to be well capitalized and competitive banks.

Actually, by liberalizing the Syrian banking sector, Syrian public banks found themselves suddenly competing against eleven of largest and strongest banks in the area. This competitive environment poses on Syrian public banks to develop their service quality and provide the best and excellent service.

III. The Significance of the Sector

In 2008, Syria achieved US\$55.20 billions as GDP. The value added of the service sector is 45% and this compares with the added value of agriculture (20 %) and industry (35%). (World Development Indicator Data base, 2009). The percent added by service sector is very imperative and vital to the economy which proves the significance of the sector.

According to Souker (2002) that developing monetary and banking system at Syrian public banks will gain great benefits to the growth and development of the economy.

2.2 Governmental policy

There are many initiatives by the Syrian Government to support national industrial or services establishment in order to produce goods or offer services that meet the needs and expectations of people with appropriate and competitive prices.

The most important one is the Syrian Quality Programme (QP) "Strengthening Quality Management, Capabilities and Infrastructures in Syria". The project, which has been under preparation since 2006, is one of the largest EU projects in Syria, with a value exceeding 12 million Euros. Fully running since May 2008, it is expected to continue for four years.

The overall objective of the project is to reinforce all elements of the Syrian quality infrastructure: standardization, conformity assessment, market surveillance & inspection, accreditation and metrology (Azmathly, 2009).

Related to the banking sector in Syria, the Syrian Government tries hard to achieve significant reform and development in the sector. Banking Sector Support Program II (BSSP II) is a project funded by the European Union during the period from January 2006 to June 2009. It has been financed by the European Commission's Delegation to Syria (€6 millions). BSSP II aims at assisting in the first stages of the institutional legislative and operational modernization of the Syrian banking sector by rationalizing banking procedures and improving banking services and products.

A key concern of this project is the improvement of the skills of staff and management at different levels of the public and private banks as well as the Central Bank. To achieve this objective Banking Training Centre (BTC) was established at 2007. It is the first formal institution to develop the financial sector in Syria. The BTC plans all the training policies and strategies for the administrative and banking programmes (Sabet, 2009).

2.3. Research significance

There is a lack of empirical studies on the factors affecting the excellence in the financial services in the developing countries generally, and in the Arabic world especially. Many authors support the view related to the shortage of service quality studies in the developing countries such as (Yavas et al ,1997; Kassem ,1998 ;Firoz and Maghrabi,1994; Angur et al ,1999; Sureshchander,et al ,2002 ; and Al marri, 2005).

For example, Sureshchander et al (2002, p182) mention “*The literature both (research and practitioner) available on these service quality issues in developing economies is far less when compared to the wealth of knowledge available about developing economies*”

To the best knowledge of the researcher that no previous study about the factors affecting the excellence of service quality at Syrian banking sector. The study will participate also to narrow the gap related to the concept of the quality in the service public organisations in developing economies.

3. Research Outline

3.1. Overall Aim of the Research

To investigate the factors affecting the excellence at Syrian public banks to improve their service quality and enable them to compete efficiently by joining the European Mediterranean partnership.

3.2. Research Objectives

- To critically review the literature and identify the factors affecting the excellence of service at banking sector.
- To identify the concept of excellence at Syrian Public banks
- To explore the factors affecting the excellence of service quality at Syrian Public Banks

- To develop an appropriate service quality model for the Syrian banking sector and context.

3.3. Research Questions

1. What are the factors affecting the excellence of service quality at Syrian Public banks?
2. How do these factors affect the excellence of service quality at Syrian Public banks?
3. Why these factors are present in Syrian Public banks?

3.4. Expected Contribution to Knowledge

- There is a limited amount of empirical studies that investigate the factors affecting the excellence at the developing countries. This study will fill a gap in the literature by investigating and identifying the unique factors related to Syrian public banks environment.
- The main contribution of this study will be to develop a conceptual model for service quality at Syrian public banks and context.

4. Research Methodology

There is no agreed consensus on how to define the research. (Hussey and Hussey, 1997). However, there is agreement that research is a process of enquiry and investigation in a systematic way to increase the sum 'of what is known, usually referred to as "a body of knowledge", by the discovery of new facts or relationship through a process of systemic scientific inquiry, the research process. (Nachmias and Nachmias, 1996; Hussy and Hussy, 1997).

Similarly Saunders *et al.* (2007, p5) defined research as “*something that people undertake in order to find out things in a systematic way, thereby increasing their knowledge*”.

The research process which adopted in this study will be discussed briefly in the following sections:

4.1 Research Philosophy (Paradigms)

Paradigms and philosophy are alternative terms in management researches.

A research paradigm “*is a framework that guides how research should be conducted, based on people’s philosophies and their assumptions about the world and the nature of knowledge*”. Collis and Hussey (2009, p.55)

There are many research philosophies in social science. Many authors, such as Easterby-Smith *et al.* (2008); Saunders *et al.* (2007); Collis and Hussey (2009); Remenyi *et al.* (1998); Hussey and Hussey, (1997) distinguish between two main philosophies: Interpretivism (social constructionism or phenomenology) and positivism. Collis and Hussey (2009) stated that positivism paradigm has some alternative terms such as quantitative, objective, scientific, and traditionalist, while qualitative, subjective, humanist and phenomenological are alternative terms for the interpretivism paradigm.

Easterby-Smith *et al.* (2008, p.57) describe positivism as assuming that “*the social world exists externally, and that its properties can be measured through objective methods rather than being inferred subjectively through sensation, reflection or intuition*”.

Collis and Hussy (2009, p.56) identifies the main criticism of positivism paradigms:

- It is impossible to separate people from the social contexts in which they exist
- People cannot be understood without examining the perceptions they have of their own activities.
- A highly structured research design imposes constraints on the results and may ignore other relevant findings.
- Researchers are not objective, but part of what they observe. They bring their own interests and values to the research.
- Capturing complex phenomena in a single measure is misleading(for example capture a person’s intelligence by assuming numerical values)

In response to positivism criticism, Interpretivism (social constructionism) has been developed as a newer paradigm and stems from the view that social ‘reality’ is not objective, but subjective, multiple, and in our minds. It is socially constructed and given meaning by people by focusing on the ways that people make sense of the world, especially through sharing their experiences with others via the medium of language (Collis and Hussy 2009, p 57; Easterby-Smith *et al.*, 2008, p58).

It is very necessary to understand the philosophical assumptions behind the research before design the project.

The following table summarised the assumptions related to two main paradigms

Table (1) Assumptions of the main paradigms

Philosophical Assumption	Positivism	Interpretivism
Ontological assumption (the nature of reality)	Reality is objective and singular, separate from the researcher	Reality is subjective and multiple , as seen by the participants
Epistemological assumption (what constitutes valid knowledge)	Researcher is independent of that being researched	Researcher interacts with that being researched
Axiological assumption (the role of value)	Research is value - free and unbiased	Researcher acknowledges that research is value –laden and biases are present.
Rhetorical assumption (the language of the research)	Researchers writes in a formal style and uses the passive voice , accepted quantitative words and set definitions	Researchers writes in an informal style and uses the personal voice , accepted qualitative terms and limited definitions
Methodological assumption (the process of research)	Process is deductive study of cause and effect with a static design(categories are isolated before hand)	Process is inductive study of mutual simultaneous shaping of factors with an emerging design (categories are identified during the process) Research is context bound patterns and/or theories are developed for understanding findings are accurate and reliable through verifications.

Source: Adapted from Creswell (1994, p.5 and 1998, p.75).

This research investigates the factors affecting the excellence of service quality at Syrian Public banks.

The interpretivism (phenomological) paradigm has been chosen for this research for the following reasons:

- Gain in depth understanding of the factors affecting the excellence of service quality at public banks in Syria. Naslund (2002); Patton (2002); Ghauri and Gronhaug (2005); Hussey and Hussey (1997); Amarantuge (2002) and Bell (1999).
- The social nature of this research where it is dealing with beliefs, realities, attitudes and experience. Interpretivism is the appropriate philosophy for studies that deal with the exchange of experience between people. Hussey and Hussey (1997) and Collis and Hussey (2009).

- The subjective aspects of human activity which is covered by this research such as the change of culture and top management involvement, and which focuses on meaning rather than measurement. This approach is also supported by researchers such as Easterby-Smith *et al.* (2008), Creswell (2003), Patton (2002), Amaratunga (2002) and Allison *et al.* (1996).
- The study focuses on words rather than numbers, on sequences of events, interactions, behaviour and transformation of culture rather than prediction, the qualitative philosophy is the most fitting, a conclusion which is supported by Miles and Huberman (1994) ;Moore (2000) and Hakim (2000).
- Phenomenology is the appropriate methodology in subjects that refer to quality management, as the present study does. Leonard and McAdam (2001)

4.2. Research Approach

There are two main research methodological approaches: deductive and inductive.

Creswell (2003) and Patton (2002) state that one of the key differences between these approaches lies in how existing literature and theory are used to guide the research. The deductive approach is designed to test a theory; thus, the literature is used to identify questions, themes and interrelationships before data are collected. By contrast, the inductive approach builds a theory as the research progresses; themes are identified throughout the research process and the literature is used to explore different topics.

Saunders *et al.* (2007) shows the major differences between inductive and deductive approaches. See Table (2).

Saunders *et al.* (2007) suggest that a combination of deduction and induction is not only perfectly possible within the same piece of research, but is often an advantageous approach (p.119). For that reason, the two approaches are adopted in this research to achieve the objectives of this research. By searching the literature all the factors affecting the excellence of service quality at banking sector will be identified and formulated then a research strategy will be designed to investigate those factors (Deductive approach). All the data which collected theoretically will be empirically tested in the field study (Inductive approach).

Table (2) the major differences between inductive and deductive approach

Deductive approach	Inductive approach
Scientific principles	Gaining an understanding of the meaning humans attach to events
Moving from theory to data	A close understanding of the research context
The need to explain the causal relationship among variables	The collection of qualitative data
The collection of quantitative data	A more flexible structure to permit changes of research emphasis as research progresses
The application of controls to ensure validity of data	A realisation that the researcher is part of the research process
The operationalisation of concepts to ensure clarity of definition	Less concern with the need to generalise
A highly structure approach	
Researcher's independence of what is being researched	
The necessity to select samples of sufficient size in order to generate a conclusion	

Source: Saunders, *at el.*, (2007, p. 120)

4.3. Research Strategy (Design)

A research strategy is a plan of how to answer research questions which will satisfy the research objectives (Saunders *et al.* 2007). There are a number of research strategies in social science research (Velde *et al.*, 2004, p. 71;Saunders at al ,2007), which include: - experiments, Surveys, histories analysis of archival information, action research , ethnography, grounded theory and case studies.

Yin (2009) lists five different types of research design, summarised in Table (3).

Yin (2009, p.17) define the case study strategy in two ways, the first being a technical definition beginning with the scope of a case study: “*an empirical inquiry that investigates a contemporary phenomenon within its real-life context, especially when the boundaries between phenomenon and context are not clearly evident.*” Secondly, the case study is defined as “*a research strategy which comprises an all-encompassing method, covering the logic of design, data collection techniques, and specific approaches to data analysis*”.

Table (3): Relevant situations for different research designs

Strategy	Form of research question	Requires control over behavioural events	Focuses on contemporary events
Experiment	How, why	Yes	Yes
Survey	Who, what, where, how many, how much	No	Yes
Archival analysis	Who, what, where, how many, how much	No	Yes/No
History	How, why	No	No
Case study	How, why	No	Yes

Source: Yin (2009, p.8)

Case study has been selected to be the main strategy in this research. The reasons will be clarified in the following section.

4.3.1. Justification for adopting Case Study Strategy

The main reasons for adopting the case study strategy are summarized as following:

- Case study strategy is appropriate if the researcher wishes to gain a rich descriptions and a deep understanding of the context of the research and the process being enacted. It is a useful way of exploring existing theory and providing influential insights. It is helpful if the aim of the research is to conduct intensive study of a phenomenon within total surrounding (Saunders *et al.*, 2007); (Bell, 1999); (Amarantuge *et al.*, 2002) ;(Velde, 2004). The case study has been selected in this research to gain in depth understanding of the factors affecting the excellence of service quality at Syrian Public banks.
- Case Study strategy is preferred when ‘how’ or ‘why’ questions are being posed. This allows the researcher to determine not only what happened but also why it happened. He also recommends case study strategy when the researcher has little or no control over the events and when the focus is on contemporary events. (Yin, 2009). This research will cover the questions related to how the excellence factors affect the service quality at Syrian public banks, and why those factors are present at Syrian public banks. The event is contemporary in Syrian organisations ,and the

researcher has no control over this phenomenon, therefore; the case study strategy is suitable for this research

- According to Blau *et al.* (1996), the strength of the case study is its ability to deal with a full variety of evidence such as documents, interviews and direct observations, beyond what might be available in the conventional historic study. By adopting the case study in this research, different methods of data collection will be used.
- Bamber (2002) suggests that case studies are ideal to study quality management issues and adds that the intangible nature of certain elements such as culture change, resistance to change and improvement in some of the organisations makes this all the more relevant.

4.3.2 Number of case studies

By adopting the case study as a strategy for this research, it is very vital to determine the number of case studies whether single or multiple.

This research will deal with two case studies for the following reasons:

- A single case study can offer greater depth of study, but it has limitations as to the generalisability of any conclusions drawn. It could also lead to bias, such as misjudging the representativeness of a single event and exaggerate easily available data. Voss *et al.* (2002).
- Yin (2009) mentions that the single case is appropriate to use when the case represents an extreme or unique case. He also states that this strategy can be used to determine whether a theoretical proposition is correct or whether some alternative set of explanations may be more relevant. Indeed, the empirical work is exposed to criticism and scepticism by depending on single case study.
- Multiple case studies are more common and are generally used to replicate findings or support theoretical generalisations. Indeed, multiple case study research increases external validity and guards against observer bias (Leavy, 1994; Lee ,1992; and Yin ,2009).

4.3.3 Justification of the Choice of Case Studies Organisations

Syria has six specialised Public banks. They are : the Commercial bank, Real Estate Bank, Industrial Bank, the Agricultural Cooperative Bank, Popular Credit Bank, , and Savings Bank.

This research will cover two case studies which are the Commercial bank of Syria and the Real Estate bank for the following reasons:

- Both case studies are public banks where this study is undertaken at Syrian Public Banks
- Both Banks are the most important banks in the Syrian Market related to the share market, long history, accumulated experiences, and web of relationships with corresponding banks. Case study “A” is the Commercial Bank of Syria is the largest state owned bank in terms of assets and has a fairly large branch network, with 60 branches spread throughout the country. The Commercial Bank of Syria claims to possess about 50 percent¹ of the market share in terms of private and public sector lending and has plans to increase its branches in the future. Case study “ B” Real Estate Bank has the widest network of branches covering all governorates, major cities, and plans to further develop its net working the close future. At the end of 2005 the customer deposits have reached / 62906 / million Syrian pounds achieving a marked increase in the last year by 15%.
- Both Banks have achieved a significant progress of performance related to customer service during the last five years which support the research’s investigation about the factors affecting the excellence of the service quality at those banks. Commercial bank of Syria had fulfilled automation project. All the branches are updated and, automatically connected. Hence, customers’ service will run more efficiently and less time consuming .Furthermore, the Bank established Automatic Teller Machines (ATM), and issued electronic Credit Cards. Similarly, Real Estate has also been pioneer in introducing a lot of automated services such as ATM, Credit Cards, and Phoenix banking system.
- Other Public Banks still work in a very old specialised mechanism since 1970s and before. Using them as case studies will not provide the research by any further dimension.
- Permission to conduct the field study has been granted and encouraged by contacting the head management of both case studies. Silverman (2002) mention that accessibility and convenience are vital factors for choosing the case studies.

¹ This figure includes public sector transactions and was provided by the Deputy General Manager of the Commercial Bank during an interview in June 2007 to reach up to 80 percent but was verified against Central Bank statistics to reach 50 percent in 2006

4.4. Data Collection Methods

According to Collis and Hussey (2003), there are two major types of data collection; primary data and secondary data.

Primary data: is data that were collected specifically for the purpose of this study.

Secondary data: were data collected for another purpose but are related to the subject of the study, and which the researcher has gathered to build the theoretical base for this study. The sources of these data were mainly: Referenced books, academic papers, researches, thesis, magazines, newspapers and Internet. Yin (2009) suggests six major sources of evidence to be used in the case study strategy; Documentation, Archival Records, Interviews, Direct Observation, Participation /Direct observation, and Physical Artefacts.

Table (4) Strengths and weaknesses of six sources of evidence

Source of evidence	Strengths	Weakness
Documentation	<ul style="list-style-type: none"> - Stable: Can be reviewed repeatedly - Unobtrusive : not created as a result of the case study - Exact: contains exact names, references and details 	<ul style="list-style-type: none"> - Retrievability: can be low - Biased selectivity, if collection is incomplete - Reporting bias : reflects bias of the author - Access : may be deliberately blocked
Archival Records	<ul style="list-style-type: none"> - Same as above - Precise and quantitative 	<ul style="list-style-type: none"> - Same as above - accessibility may be limited for privacy reasons
Interviews	<ul style="list-style-type: none"> - Targeted : focuses directly on case studies - Insightful: provides perceived causal inferences 	<ul style="list-style-type: none"> - Bias due to poorly constructed questions - Response bias - Inaccuracies: interviewees say what they think interviewer wants to hear
Direct observation	<ul style="list-style-type: none"> - Reality : covers events in real time - Contextual : covers context of event 	<ul style="list-style-type: none"> - Time consuming - Selectivity: poor, unless broad coverage - Reflexivity: events may be processed differently
Participation / direct observation	<ul style="list-style-type: none"> - Same as for direct observation - Insightful into interpersonal behaviour and motives 	<ul style="list-style-type: none"> - Same as for direct observation - Bias due to investigator's manipulation of events
Physical Artefacts	<ul style="list-style-type: none"> - Insightful into cultural features - Insightful into technical operations 	<ul style="list-style-type: none"> - Selectivity - Availability

Source: Yin (2009, p102)

A comparison list about the strengths and weaknesses of these sources is available in Table (4) .Yin (2009) concludes that no single source of data has a complete advantage over others, while the use of multiple sources of evidence can help in clarifying the real meaning of the phenomena being studied.

The main method in this research will be semi structured, face to face interviews. Indeed the researcher will use documentations and direct observation as resources to collect more data.

5. Summary

An investigation of both case studies Commercial bank of Syria and Real Estate bank will be conducted to explore the factors affecting the excellence of service quality at Syrian Public banks. Interpretivism paradigm will be the main philosophy of this research depending on the ontological assumption that reality is subjective and multiple, as seen by the views of the interviewees. The research will try to identify an explanation of human actions by understanding the way in which the world is understood by individuals. Deductive and inductive approach will be adopted to achieve the objectives of this research. Case study will be the main strategy to design this research. Semi structured Interviews, documentations and observation are the essential methods to data collection.

6. References

- Alison B., O'Sullivan T., Owen A., Rice J., Rothwell A. and Saunders C. (1996), "Research skills for students". Kogan page Ltd & Deontfort University, UK.
- Al Marri,K,S. (2005) " Achieving Excellence in Services (An empirical Study in The UAE Banking Sector)",PhD Thesis ,School of Management, University of Bradford.
- Amaratunga D. (2002), "Quantitative and qualitative research in built environment: application of "Mixed" research approach", Vol. 51, No. 1, Pp. 17-31.
- Angur ,M.G,Natarajan,Rand Jahera,J.S.Jr (1999) . "Service Quality in the Banking Industry : as assessment in a developing economy" .International Journal of Bank Marketing.Vol.17, PP.116-23
- Azmashly,S.(2009). "The EU funds the largest quality project in Syria" .Alhyat. Damascus . Europa Jaratouna Newsletter (Window on the Euromedeterian Life) <http://www.eurojar.org/en>
- Bamber C., (2002), "Agile Manufacturing in UK Aerospace Small to Medium Size Enterprises", PhD Thesis, Salford University.
- Bell J. (1999) "Doing Your Research Project: A guide for first time researchers in education" 3d Ed, Jedith Bell.

Bisignano, J. (1992), "Banking in the European Economic Community: structure, competition and public policy", in Kaufman, G.G. (Ed.), *Banking Structures in Major Countries*, Kluwer Academic Publishers, Boston, MA.

Creswell, J.W. (1994) "Research Design: Qualitative and Quantitative Approach", Thousand Oaks, CA: Sage.

Creswell J. (2003) "Research design: Qualitative and Quantitative Approaches", California: Thousand Oaks, SAGE Publications

Collis J. and Hussey R., (2003) "Business research: a practical guide for undergraduate and postgraduate students", New York: Palgrave Macmillan, Second Edition.

Collis, J. and Hussey, R. (2009) "Business Research A practical Guide for Undergraduate and Postgraduate Students" . 3ed .Palgrave Macmillan: UK

Easterby-Smith M., Thorpe R. and Lowe A. (2008) "Management Research", 3 ed. SAGE Publications Ltd, London.

Firoz, N.M, and Magharbi, A.S (1994) "The role of service marketing in economics development: an analysis". *International Journal of Management*, Vol 2, pp 641-747.

Ghauri N. and Gronhaug K. (2005), "Research methods in business studies: A practical guide", fifth Edition, Prentice Hall: New York.

Habeeb, H. (2002). "The Euro Mediterranean Partnership Pros and Cons: An Arabic view" Universal Publishers. USA 2002

Hakim C. (2000), "Research design, successful designs for social and economic research", 2nd Edition, Routledge Publications.

Hussey J. and Hussey R. (1997), "Business research: a practical guide for undergraduate and postgraduate students", London: Macmillan Press

International Monetary Fund, IMF country report No.09/55 (2008). Syrian Arabic Republic Article IV Consultation .Concluding Statement. October 29, 2008. <http://imf.org/external/np/ms/2008/102908.htm>

Kassem, S. (1998) . "Service Marketing the Arabian Gulf Experience" .*Journal of service marketing*. Vol 3, pp 61-71

Kim, S and Kleiner, B.H. (1996). "Service excellence in the banking industry"
Managing Service Quality, Volume 6 No. 1 pp. 22–27

Leavy B. (1994), "The Craft of case-based, in Qualitative Research". *Irish Business and Administrative Research*, Vol. 15, No.4, Pp. 105-118.

Lee S., (1992) "Quantitative versus qualitative research methods: two approaches to organisation studies", *Asia Pacific Journal of Management*. Vol. 9, No. 1, Pp. 87-94.

Lewis, A. and Pescetto, G. (1996), "EU and US Banking in the 1990s", Academic Press, London.

Leonard D. and McAdam R., (2001) "Developing strategic quality management: a research agenda", *Total Quality Management*, Vol. 13, No. 4, Pp. 507-522

Macdonald, J. (1995). "Quality and the financial service sector". *Managing Service Quality Volume 5* No. 1 pp. 43–46

Miles M. B. and Huberman A. M. (1994), "Qualitative Data Analysis: An extended source book, 2nd Edition, Sage Publications, London.

Moore N. (2000) "How to do research: the complete guide to designing and managing research project, Library Association Publication, London.

Naslund D. (2002), "Logistics needs qualitative research- especially action research". *International Journal of physical Distribution & logistics management*. Vol. 17, No. 3, Pp. 226-258

Nachmias ,C.F,and Nachmias ,D.(1996). "Research Method in the social science" Worth Publishers , U.S.A

Patton M. Q. (2002), "Qualitative research and evaluation methods", 3rd Edition, Thousand Oaks, CA: Sage.

Remenyi D., William B., Money A., and Swartz E. (1998), "Doing Research in Business and Management": An Introduction to process and Method, Sage Publications, London

Sabet, A. (2009). "Financial Sector Development and Capacity Building: The Case of Syria" GFA Consulting Group Publication. http://www.gfa-group.de/gfa-consulting_group/gfa_consulting_group_beitrag_890342.html

Saunders M., Lewis P., Thornhill A., (2007), "Research Methods for Business Students", 4nd Edition, London: Financial Times Prentice Hall.

Silverman, D (2002). "Doing Qualitative Research: A practical Handbook", London, SAGE Publication Ltd

Soukar, Nabil (2002). " When will Banks Reforms start in Syria? " The Fifteenth Tuesday Forum on Economic and Social Development in Syria "To make Economic Reforms more Efficient" Damascus.12/3/2002. Syrian Economic Society Lectures www.syrianeconomy.com

Sureshchander G.s, Rajendran C, ,Anantharaman, R.N and Kamalanabhan, T.J. (2002) "Management's perception of total quality service in the banking sector of a developing economy- a critical analysis". *International journal of bank marketing* 20/4 [2002] 181-196

Velde, M.v.d., Jansen,P.&Anderson, N.(2004) “Guide to Management Research Methods”, Malden, Blackwell Publishing Ltd.

Voss C., Tsiriktsis N., Frohlich M. (2002), “Case research in Operations Management”. International Journal Of Operations & Production management, Vol. 22, No. 2, Pp. 195.

Wang, Y., Lo, H. and Hui, Y.V. (2003), “The antecedents of service quality and product quality and their influences on bank reputation: evidence from banking industry in China”, Managing Service Quality, Vol. 13 No. 1, pp. 72-83.

World Development Indicators database (2009). Syrian Arab Republic. April 2009 Available at: http://ddpext.worldbank.org/ext/ddpreports/ViewSharedReport?&CF=1&REPORT_ID=9147&REQUEST_TYPE=VIEWADVANCED&HF=N&WSP=N

World Bank Report (2008).Policy and Regulatory Framework for Microfinance in Syria January 2008 http://wwwds.worldbank.org/external/default/WDSContentServer/WDSP/IB/2008/05/02/000333037_20080502014209/Rendered/PDF/434330WP0Syria10box032736801PUBLIC1.pdf

Yavas, U., Bilgin ,Z.and Shemwell, D.j.(1997)“Service quality in the banking sector in an emerging economy : a consumer survey”. International Journal of Bank Marketing Vol.15 PP. 217-23

Yin R.K. (2009) “Case study Research: Design and Methods”, 4rd Edition, Sage Publications

Blau, J., Xiao, H., McCracken, S., O’Hare, P., Greenblatt, J. & Bentley, D. (1996). Three functional classes of transcriptional activation domain. *Molecular and Cellular Biology* 16, 2044-

2055.[\[Abstract/Free Full Text\]](#)

***Little Dorrit*'s Rigaud: Stock Melodramatic Villain or Clinical Portrait of Psychopathy?**

Abby Bentham, *University of Salford*

Abstract

Rigaud Blandois, the villain in Charles Dickens's eleventh novel, has been described as 'a much simpler, more symbolic, creation than [Dickens's] other murderers' (Collins, 1962, p.281). Critics such as J.C. Reid have argued that Rigaud represents the 'stock foreign villain of melodrama' (1965, p.17); a 'flat' character lacking verisimilitude, whose credibility is sacrificed for dramatic effect. Evidence supporting this description of Rigaud abounds, yet he is far more realistic and convincing than one might first acknowledge.

Indeed, even Rigaud's flamboyant overacting is realistic — Dickens modelled his villain on Pierre-François Lacenaire, a double murderer who was guillotined in 1836. Like Rigaud, Lacenaire was 'work-shy with genteel pretensions and took to a life of theft, extortion, forgery and murder for gain' (Sucksmith, 2008, p.viii). Lacenaire also appears to have exhibited many of the key traits of psychopathy — traits shared by his fictive counterpart. In Rigaud, Dickens presents an extraordinarily detailed portrait of a psychopath; a feat all the more remarkable for the fact that the term 'psychopath' did not emerge until almost thirty years after *Little Dorrit* was published. With reference to Robert Hare's *PCL-R* diagnostic tool, I show how Dickens has created a clinically accurate psychopathic figure. The resultant Rigaud, far from being a flat, simple and symbolic creation, is so replete with lifelike detail that he lives in the reader's memory long after the book has been put down.

In this paper I aim to show how, in Rigaud, Dickens presents an extraordinarily detailed, clinically accurate portrait of psychopathy — a feat all the more remarkable for the fact that the term ‘psychopath’ did not come into common usage until almost thirty years after *Little Dorrit* was published. The resultant Rigaud, far from being a flat, simple and symbolic creation, is replete with plausible psychological detail.

Before we begin our examination of the text, I’ll first outline two key terms. The term ‘melodrama’ is typically applied to a literary work that incorporates implausible events and sensational action in a plot primarily concerned with a conflict between good and evil. Peopled by a cast of stock characters who lack verisimilitude, the melodrama usually revolves around themes of love and crime and has at its heart a dastardly villain. The villain is usually recognised by his moustache-twiddling, cape-tossing, often murderous behaviour — popular examples include *Chitty Chitty Bang Bang*’s Child Catcher, and the numerous villains who tied helpless heroines to train tracks in the silent movie era, a trope established by the 1914 film series *The Hazards of Helen*.

The term ‘psychopath’ denotes a severe personality disorder typified by antisocial behaviour and a profound lack of empathy for others. The term has fallen out of use in recent years because of its popular appropriation as meaning ‘dangerously mad’. It is usually replaced by ‘anti-social personality disorder’, which the American Psychiatric Association’s Diagnostic and Statistical Manual IV diagnoses via a number of criminal and antisocial behaviours. However some clinicians, such as Robert Hare, prefer to retain the term ‘psychopath’ as it assesses both personality traits and socially deviant behaviours, whilst recognising that not all psychopaths are criminals. Hare has formulated the Psychopathy Checklist–Revised, or PCL-R, diagnostic tool which rates people against a number of characteristics relating to emotional and interpersonal skills, and social deviance. In the discussion that follows we’ll be focusing primarily on the following:

Glibness and superficiality

Egocentricity and grandiosity

Lack of remorse or guilt

Lack of empathy

Deceitful and manipulative behaviour

Shallow emotions

Early behavioural problems

Adult antisocial behaviour (Hare, 1993, p.4)

So, now we have terms we can apply to the character of Rigaud to more properly assess whether he is merely a stock melodramatic villain, or a fully realised psychopath.

Rigaud carries all of the markers of the melodramatic villain, from his overblown mannerisms and phraseology, to his flamboyant clothing and gentlemanly pretensions. Dickens has codified Rigaud's immorality in his grotesque appearance and physical movements: he has 'eyes like pointed weapons with...no depth or change...a hook nose...thin lips...[and a] thick moustache' (p.3). When he laughs his face does not take on a softer, more kindly aspect, rather '[h]is moustache went up under his nose, and his nose came down over his moustache, in a very sinister and cruel manner' (p.5). Rigaud's cold, dead eyes, cruel mouth, mobile moustache and ghostly white skin act as physiognomic signals which allow the reader to identify him when he is disguised in the text by one of his many pseudonyms. Perhaps more importantly, these corporeal irregularities also signify his moral deformity; his true character written on his body.

However, despite his falsity and theatricality, the characterisation of Rigaud is actually based on fact. Dickens modelled Rigaud on Pierre-François Lacenaire, a double murderer who was guillotined in 1836. Lacenaire appears to have exhibited many of the key traits of psychopathy, including egocentrism, lack of remorse or guilt, deceitful and manipulative behaviour, early behavioural problems, and criminal versatility. His detached attitude towards his crimes, coupled with his charm and flamboyant appearances in court, captivated his contemporaries. In his article 'The Melodramatic Villain in *Little Dorrit*', Harvey Sucksmith describes Rigaud as 'powerfully realistic and, at the same time paradoxically enough, artificial...his falseness is dramatically presented' (1975, p.82). However, this 'falseness' is not evidence of Rigaud's status as melodramatic villain; rather it supports our view of him as a clinical portrait of psychopathy. The true psychopath, according to Hare, is eccentric and grandiose, lacks empathy and has shallow emotions. Personality often becomes performative, with psychopaths adopting the traits that will appeal to those they are attempting to manipulate.

Like the real-life psychopath who is unable to connect with his fellow humans on an empathetic level, Rigaud too remains at a distance from the reader. His discourse is direct and, perhaps most significantly, spoken out loud — even when he is alone. Rigaud jealously guards his inner self from sight and, as the author, Dickens colludes in this act by denying us access to Rigaud's psyche. We know what Rigaud is thinking because his thoughts are vocalised yet by voicing them, rather than allowing us to 'hear' Rigaud's internal monologue, Dickens ensures that the reader is kept on the outside, in an unprivileged position. This is not how other characters in *Little Dorrit* are presented.

Rigaud's is not the only voice in the novel. As Simon Dentith points out, 'novelistic prose has built into it more than one consciousness' (1995, p.196). Mikhail Bakhtin explores this notion in his discussion of 'heteroglossia' which, in Russian, literally means 'different speechness'. It refers to the existence of, and dialogic interaction between, different types of speech, including (but not limited to) dialects, genres and registers, socially and historically formed.

For Bakhtin, each heteroglot language carries a particular standpoint, characterised by its own meaning, values, and world view. He argues that one of the simplest forms of heteroglossia is 'incorporated genres', which typically 'preserve within the novel their own structural integrity and independence, as well as their linguistic and stylistic peculiarities' (ibid. 215). This is significant when we consider Rigaud's characterisation as a melodramatic villain. As we have seen, Dickens invests greatly in Rigaud's melodramatic persona, from his manner of speaking to his style of dress, even his physical movements. An interesting example of this comes in the scene at the Break of Day Inn, when Rigaud becomes intrigued as to the identity of the person whose bedchamber he is sharing. At this point, Rigaud himself has not been named and is variously referred to as 'the guest', 'the traveller', and so on. This adds not just to the mystery surrounding Rigaud's identity but also to the tension of the scene, as he creeps across the room to catch a glimpse of the sleeper:

The waking traveller...stole a little nearer, and yet a little nearer, and a little nearer, to the sleeping traveller's bed, until he stood close beside it. Even then he could not see his face, for he had drawn the sheet over it. The regular breathing still continuing, he put his smooth white hand (such a treacherous hand it looked, as it went creeping from him!) to the sheet, and gently lifted it away.

"Death of my soul!" he whispered, falling back, "here's Cavaletto!" (p.109)

Rigaud's exaggerated tiptoe across the room would not be out of place in a pantomime (which Peter Brooks tells us is a form from which melodrama derives 1976, p.62). Every part of this passage impresses upon us Rigaud's dastardly nature, from his 'treacherous' ghostly hand, to his reaction on discovering the sleeper's identity. The hand seems to work independently of Rigaud, bringing to mind the detachable body parts of the grotesque. As it goes 'creeping from him' there seems to be no limit to the amount of mischief or evil it could commit and this adds to our impression of Rigaud as diabolical and 'othered'. His actions and exclamation on uncovering Cavaletto are equally melodramatic, tying him tightly to the genre that defines him by his immorality.

Juliet John makes the point that, as a genre, melodrama typically avoids interiority on the assumption that surfaces have a broader meaning, that their outward simplicity signals the complexity beneath. She argues that in *Little Dorrit* Dickens is exploring the possibility that this is not the case, with ‘the Gothic villain Rigaud Blandois and his prose environment [foregrounding] Dickens’s exploration of a world devoid of interiority’ (2001, p.112). This is interesting on a number of levels. The first is her reference to Rigaud’s ‘prose environment’, by which she presumably means both the way he is spoken of (i.e. narrated), and the way in which he speaks, within the context of the novel. Now, whilst I would agree that Rigaud lacks psychological depth, I do not agree that his prose environment lacks complexity. Heteroglossia is, by its very nature, complex, representing the dialogic clashes and conflicts between diverse languages within a single utterance or passage.

John explains how Rigaud’s lack of interiority is a consequence of his melodramatic posturing and his ‘constant externalization of passion’ (ibid.113), arguing that ‘if innerness is constantly made visible, then arguably there is nothing left inside’ (ibid.). This is a compelling argument, yet one can equally maintain that Rigaud’s hollowness relates to his psychopathy, a biological disorder over which he has no control, rather than manifesting as a side-effect of the conscious performativity of his identity.

Hare describes psychopaths as suffering from:

a kind of emotional poverty that limits the range and depth of their feelings. While at times they appear cold and unemotional, they are prone to dramatic, shallow, and short-lived displays of feeling. Careful observers are left with the impression that they are play-acting and that *little is going on below the surface*. (1993, p.52, my emphasis)

If we accept that in Rigaud Dickens has drawn a very accurate portrait of a psychopath, it follows that it is not that the melodramatic ‘externalization of passion’ has made passion meaningless, as John suggests, but rather that this passion never existed in the first place.

Rigaud’s psychopathy is also revealed in his killing of Gowan’s dog, an episode that is particularly interesting when viewed from a clinical perspective. Rigaud’s casual, even triumphant account of the dog’s demise indicates his lack of empathy, lack of remorse or guilt, and poor behavioural controls — all key indicators of psychopathy on the PCL-R. Profound cruelty to animals is a well-documented childhood precursor to psychopathy, which appears on the MacDonald triad. In his 1963 article ‘The Threat to Kill’, which appeared in *The American Journal of Psychiatry*, J.M. MacDonald identified a set of three behavioural characteristics which when exhibited in childhood can indicate a propensity to severe

personality disorder. His findings have been corroborated by many later studies, including the research of Hare who notes that '[e]arly cruelty to animals is usually a sign of serious emotional or behavioural problems' (1993, p.66). Indeed, many of the most notorious killers of recent times had well-documented histories of precocious sadism and animal abuse. Perhaps most significantly for our discussion of Rigaud's attitude to killing Gowan's dog, Hare also points out that '[a]dult psychopaths usually describe their childhood cruelty to animals as ordinary events, matter-of-fact, even enjoyable' (ibid.). Rigaud's smiling, shoulder-shrugging, insouciant account of the dog's death stands in sharp contrast to the horror with which Amy Dorrit reacts to the news.

In these small ways Rigaud's true character is continuously revealed, despite his efforts to conceal it. Throughout the novel people struggle in their evaluation of his character; Amy and Mrs. General, however, are not easily fooled — they see him as 'an odious creature of the reptile kind' (Dickens, p.426). This reference to reptiles is interesting when considered in relation to the psychopath, and represents another example of Dickens' remarkable insight into the disorder. We have already heard of Rigaud's cold, empty eyes — for forensic psychiatrist J. Reid Meloy the gaze of the emotionless, predatory psychopath is as cold as a reptile's blank stare. Meloy has suggested that the psychopath is a predator; a human functioning from the 'reptilian brain'. The reptilian brain is primarily concerned with physical survival and, significantly, it also plays a crucial role in establishing social dominance. Some clinicians believe that, in the psychopathic subject, this primitive brain takes precedence over the higher functioning neocortex, which gives us reason, and the limbic system, which is responsible for emotion. Reptiles lack a limbic system and, like the psychopath, have no capacity for emotion or empathy. Dickens's seemingly casual use of this conventional image, then, is highly significant. It allows him to describe, in metaphorical shorthand, the absence in the psychopath of the constituent parts of genuine humanity, and represents a conscious othering of Rigaud's freedom from restraint. Yet this othering is not simply a stylistic literary device; rather it functions as a moral counterbalance to the more appealing elements of Rigaud's character.

Freedom from the strictures of Victorian society seems to have appealed to Dickens and perhaps goes some way towards explaining his wider fascination with criminality, and criminal psychology in particular. Although Albert Borowitz has argued that Dickens 'felt a strange empathy for criminals whose impulses seemed to raise an echo from some of the darker recesses of his own personality' (2002, p.11), the affinity Dickens felt with such figures seems to have been at once thrilling and terrible to him. Sadly there is neither time nor space here to discuss the tensions between the good and bad 'selves' that Dickens

saw in every human being, but explorations of this theme abound throughout his work. Through them, Dickens is able to test the limits of humanity and reflect on man's capacity for depravity, before meting out justice and retribution to restore the status quo. These themes reveal *Little Dorrit* to be a rich and detailed novel, which demonstrates Dickens's astonishing eye for clinical detail. What is clear is that Rigaud, although clearly in the mould of the melodramatic villain, is an extraordinarily complex creation. Dickens uses the markers of melodrama to point us towards the darkest depths of human psychopathology and in so doing creates one of literature's most memorable characters.

References

- Borowitz, A. 2002. *Blood & Ink: An International Guide to Fact-Based Crime Literature*. NP: Kent State UP.
- Brooks, P. 1976. *The Melodramatic Imagination: Balzac, Henry James, Melodrama, and the Mode of Excess*. 1995. New Haven: Yale UP.
- Collins, P. 1962. *Dickens and Crime: Third Edition*. New York: St. Martin's Press.
- Dentith, S. 1995. *Bakhtinian Thought: An Introductory Reader*. London: Routledge.
- Dickens, C. 1857. *Little Dorrit*. 2008. Oxford: Oxford UP.
- Hare, R. 1993. *Without Conscience: The Disturbing World of the Psychopaths Among Us*. New York: Guilford Press.
- John, J. 2001. *Dickens's Villains: Melodrama, Character, Popular Culture*. Oxford: Oxford UP.
- Reid, J.C. 1965. *Charles Dickens: Little Dorrit*. 1975. London: Edward Arnold.
- Sucksmith, H. P. 1975. The Melodramatic Villain in *Little Dorrit*. *The Dickensian*, 71 (Spring Number), pp.76-83.

Unravelling ecological genetics in the face of environmental change: the case of the common toad (*Bufo bufo*)

R. Coles, *School of Environment and Life Sciences, University of Salford*

Abstract

The Millennium Ecosystem Assessment (2005) regards current climate change, involving the rise in temperature associated with alterations in precipitation and atmospheric CO₂ concentrations, as a main contributor for adverse effects on environments. It has been estimated that global biodiversity has declined by more than 25% over the last 35 years. Amphibians are the most severely affected vertebrate group, with 32% of the currently known species being threatened with extinction. The common toad (*Bufo bufo*) is the most populous amphibian found in the UK, and despite its occurrence associated with human-altered environments has been shown to suffer from environmental change. A 22-year study in Southern England (led by Dr. Chris Reading, NERC Centre for Ecology and Hydrology, Oxford) indicates that increased annual temperatures can be linked to the decline of individual body condition (body mass-body weight ratio). The current study aims to identify a relationship between life history traits (such as size, weight, reproductive timing and success) of the common toad with information derived from DNA via genetic fingerprinting using microsatellites. The specific hypotheses to be tested include: (I) Has the observed fecundity reduction led to a situation where fewer individuals are transmitting their genes to a following generation? (II) Are there any associations between individual-specific genotypes (DNA profiles) and the amount of fitness reduction observed under increased temperatures? (III) Are fitness traits inherited across generations (e.g., do fecund females produce fecund daughters)?

1. Introduction

1.1 Environmental change and evolutionary adaptation - adaptation

The Millennium Ecosystem Assessment (MEA, 2005) regards current climate change, involving the rise in temperature associated with alterations in precipitation and atmospheric CO₂ concentrations, as a main contributor for adverse effects on global environments and the existing biodiversity. Indeed, many species' physiology, phenology and distribution have already been affected by climate change: alterations

in atmospheric CO₂ levels directly affect the metabolism and development of many organisms, while life cycle events can be affected when environmental cues such as degree days are altered. Shifts in distributional ranges have been observed in many animals, such as flying insects, birds, marine invertebrates and terrestrial mammals (Parmesan *et al.*, 1999, Beever *et al.*, 2003) and involve individuals moving upwards and polewards in response to shifting isotherms. Indeed, a 3°C increase in mean annual temperature equates to an approximate shift in isotherms of 300-400 km in latitude or 500 m in altitude (Hughes, 2000).

Many animals also exhibit plastic responses to climate change, enabling them to produce alternative phenotypes when exposed to different environmental conditions, without any change in genetic composition. This phenomenon, known as phenotypic plasticity, has been observed in many species, for example causing an advancement of parturition dates in the red squirrel *Tamiasciurus hudsonicus* (Re´ale *et al.*, 2003), the great tit *Parus major* (Charmantier *et al.*, 2008) and the collared flycatcher *Ficedula albicollis* (Przybylo *et al.*, 2000) due to increased spring temperatures.

Finally, microevolutionary adaptations can also occur in response to environmental change, such as in Darwin’s Finches, whereby beak shape and body size altered in response to the effects of climate change on food resources (Grant & Grant, 2002). Similarly, the pitcher plant mosquito *Wyeomyia smithii*, in response to a longer growing season, have shifted their genetically controlled photoperiodic response toward shorter, more southern daylengths over the last 30 years (Bradshaw & Holzapfel, 2001). These three fundamental modes in which populations respond to climate change, range shifts, plastic responses or genetic change, are all well documented (Hughes, 2000; Visser, 2008; Phillimore *et al.*, 2010). However, discerning the magnitude of each response, especially plastic versus evolutionary changes (Gienapp *et al.*, 2008), is essential for our understanding of how populations will respond to anticipated climate change.

1.2. Local adaptation

Many animal populations can be subdivided into smaller populations (demes), such that each is individually adapted to a specific habitat patch. When other forces and constraints are absent, each local population, by means of divergent selection, can develop traits that are beneficial within the new local environment. Furthermore, residents of the local environment should have an average increased level of fitness than other individuals from other demes, as per individual genotypes. Thus, local adaptation infers

that individuals are evolutionary adapted to their local habitat and hence are genetically differentiated from individuals from other demes (e.g. Philimore *et al.*, 2010). Notwithstanding the driving force behind local adaptation that is divergent selection; fundamental to its processes are other forces such as, natural selection, genetic drift and gene flow. Moreover, local adaptation is not necessarily limited to areas of patchy, discrete individual habitats but can also occur in sympatric environments or areas of environmental gradients (reviewed by Kawecki & Ebert, 2004).

Specific examples of local adaptation studies include that of fish (Raeymaekers *et al.*, 2007) showing that the three-spined stickleback exhibited differences in plate number, short gill rakers and spine length between lowland and upland populations. Similarly, differences have been shown in the timing of migration and spawning for two temporally disparate migratory runs of Chinook salmon (O'Malley *et al.*, 2007). Another study that performed proteomic analysis of the midgut in geographically dispersed honey bee populations revealed differences in metabolic capacity, such that each was optimised to their respective different climatic region (Parker *et al.*, 2010). Local adaptation in amphibian populations has also been shown by Phillimore *et al.*, (2010), whereby translocations of British north-eastern common frogs (*Rana temporaria*) to the south-west resulted in delayed spawning by 33.5 days later than the resident population. Similarly, an increased tolerance to salinity was observed by the brackish water (saline) populations of *Bufo calamita* than the freshwater populations, indicating local adaptation to the more saline environment (Gomez-Mestre & Tejedo, 2003).

In addition to climate, local adaptation can also be affected by habitat fragmentation. This is due to populations often becoming very small and isolated when fragmented, and subsequently results in an increase in genetic drift. Due to the increase in genetic drift and thus the increased fluctuating allele frequencies, selection is prevented from causing genetic change towards adaptation (Frankham *et al.*, 2002).

2. Habitat fragmentation

Human activities such as infrastructure implementation (López *et al.*, 2010) and urbanisation carry detrimental effects to populations by causing complete loss or fragmentation of habitats. As a result, artificial barriers to migration are created and only if these barriers are crossed can species respond to climate change. Barriers preventing species migration give an increased likelihood for population decline and extinction (Collingham & Huntley, 2000). For example, Warren *et al* (2001) revealed a decline in

British butterfly species due to the absence of suitable habitats to colonise. When individuals attempt to track climate change by migrating to other habitats to which they are climatically adapted they have difficulty doing so as these areas may be too isolated or unsuitable.

3. Pedigrees

It has been estimated that global biodiversity has declined by more than 25% over the last 35 years (Collen *et al.*, 2008), and integral to the understanding of this decline is a sound knowledge of population dynamic processes (Moss *et al.*, 1982). Wildlife population studies have traditionally focused on situations where the fate of every individual within a population can be traced back. The advent of DNA-fingerprinting provides the additional opportunity for reconstructing detailed genetic relationships across several generations. Analysing connections between measures of individual fitness (such as longevity, weight and size, or genetic heterozygosity) and their changes across generations as traced back through pedigrees can provide direct insights into the mechanisms of population regulation in the face of environmental change (for seminal studies see e.g. Merilä *et al.*, 2002; Clutton-Brock & Pemberton, 2004). Moreover, pedigrees allow estimates of heritability, inbreeding and gene flow by calculating coefficients of relatedness, which also have implications for population regulation and hence conservation biology (Pemberton, 2008; Jones & Wang, 2009). However, such data are notoriously difficult to obtain and so far limited to birds and mammals

4. Amphibians

Within the vertebrates, amphibians are the group which is most severely affected by the current biodiversity crises, with 32% of the currently known species being threatened with extinction (Stuart *et al.*, 2004). Amphibians are also generally considered an indicator species due to their environmental sensitivity, thus being able to provide insights to subtle environmental problems (Hopkins, 2007). Environmental change has been shown to have significantly disrupted the timing of breeding in North American as well as British species (Beebee, 1995; Blaustein *et al.*, 2001; Tryjanowski *et al.*, 2003), and modelling suggests that the climate-driven spread of a disease led to the extinction of an important species in a pristine nature reserve in Central America (Pounds *et al.*, 2006). However, the basis of climate-driven deteriorations in individual performance still has to be revealed.

5. The common toad

The common toad (*Bufo bufo*) is the most populous amphibian found in the UK, and despite its occurrence associated with human-altered environments has been shown to suffer from urbanisation (for example Hitchings & Beebee, 1998). Remarkably, a continuous 22-year study on common toads in southern England represents one of the largest population data sets on amphibians worldwide (e.g. Reading, 2003, and references therein), and a recent analysis could directly link the performance of individuals (body mass index as a proximator for individual fitness) to annual temperature variation and the timing of breeding (Figure 1, Reading 2007). The data collected for this population provide a unique opportunity to reveal the underlying genetic (heritable) basis of the observed correlation between environmental parameters and individual performance.

6. Study Site & Population

The current study is borne out of the ongoing research by Chris Reading (Reading, 1986; Reading, 1998; Reading & Clarke, 1995; Reading & Clarke, 1999; Reading, 2001). The study site is a pond, formed from a flooded clay pit, located to the north of the Purbeck Hills in South Dorset, southern England. The habitat, where the population breeds, spans approximately 0.34 hectares and is flanked by dense rhododendron wood, mature deciduous woodland, wet scrub woodland dominated by birch, mature Scots pine, pasture and heathland dominated by *C. vulagris* and *U. europaeus*.

The total number of male and female toads arriving at the pond to mate has been recorded annually since 1980, with each individual being toe-clipped to indicate the year of capture. Other demographic information such as the size (SVL) and weight (body mass) of each individual, along with the date of first spawning and first emergence of toadlets (since 1984 but excluding 1987) has also been recorded.

The meteorological data such as temperature records were taken from the Swanage weather station, located approximately 12 km from the study site (Reading, 2007). The ongoing research has revealed relationships between changing environmental conditions and fitness-associated traits. Increased annual temperatures affect the timing of breeding activity (Reading, 1998) and on body condition (e.g. Reading & Clarke, 1995; Reading, 2007). The current study aims to reveal the underlying mechanisms of these observations as per genetic profiling of the common toad population.

7. Materials & Methods

In total, 1088 toe clippings (Fig. 1) have been used for the current study, provided by Dr. Chris Reading. The number of samples, including single toads and pairs, varies between the years due to population size fluctuation. Thus, in 2004, 2005 & 2006, the pairs (males & females in amplexus) of toads used are assumed to be the parents of toads in the later years of 2006, 2008 and 2009 (common toads reach sexual maturity at around 3-4 years). Furthermore, an additional 100 male toads* will be sampled to establish the differences between reproductively successful and unsuccessful males; and, samples from 1982 are of unknown sexes will allow comparisons of the genetic composition of the population over a long time period. Individuals from 2007 have been omitted from the study due to the large sample size of that year, because a larger sample size means many more possible parents and hence statistically less reliable results

Year	♀	Sex	♂	Total
1982	Unknown		Unknown	100
2004	124		124	248
2005	62		62	124
2006	58		58	116
2008	100		100	200
2009	100		200*	300
				1088

Figure 1. Total number of toe-clippings as per sampling year and sex of toad

DNA extraction was performed using a standard phenol/chloroform protocol and the polymerase chain reaction (PCR) performed as per the technique and PCR primers characterised by Brede *et al.*, (2001). All PCR products will be genotyped using a standard procedure on the ABI3130 96-well genetic analyser. The data obtained from the genotyper will be analysed using various freeware programs such as Peak Scanner & Genepop.

7.1. Specific hypotheses to be tested

(1) *Has the observed fecundity reduction led to a situation where fewer individuals are transmitting their genes to a following generation?* Body size is often highly correlated to fitness associated traits such as longevity, metabolic rate and fecundity (Calder, 1995). For example, studies on mammals (Conaway *et al.*, 1974) and birds (Jetz *et al.*, 2008) have shown the differences in female body size due to geographical variation, affects subsequent clutch size. Similarly, amphibians have been studied with comparable results, except that for Castellano *et al.*, (2004), both the clutch size and offspring size of *Bufo viridis* was affected. Since a reduction in clutch size reduces the survival chances of some tadpoles, the effective population size also becomes reduced. As a result of the underlying demographic and ecological factors affecting mating system processes, skews, such as male-biased ones, may develop. Indeed, the effective population size/consensus size ratio is already somewhat skewed for amphibians (Ficetola *et al.*, 2010), with a higher variance of reproductive success indicated for the common toad compared to other amphibians (Brede & Beebee, 2004). This is of concern when considering the long-term viability and potential detrimental effects of genetic erosion in isolated populations (Frankham *et al.*, 2002).

(2) *Are there any associations between individual-specific genotypes (DNA profiles) and the amount of fitness reduction observed under increased temperatures?* Heterozygosity is often correlated with fitness, since inbreeding favours homozygosity which subsequently, can result in the increase of deleterious recessive alleles. Inbreeding depression studies, by virtue of pedigree-based breeding experiments, have been conducted (reviewed in Hansson & Westerberg, 2002); and heterozygosity-fitness correlations have been shown (e.g. Hildner & Soule, 2004; Fitzpatrick & Evans, 2009). However, studies have focused on organisms such as mammals (Ruiz-Lopez *et al.*, 2009), birds (Blomqvist *et al.*, 2010) and amphibian tadpoles (Kraaijeveld-Smit *et al.*, 2006; Ficetola *et al.*, 2010). The current study aims to investigate this phenomenon of heterozygosity-fitness correlations, of which, at present, no such studies for adult amphibians exist.

(3) *Are fitness traits inherited across generations (e.g., do fecund females produce fecund daughters)?* High levels of genetic diversity are required for species to adapt when confronted with changing environmental conditions or threats such as disease, parasites or predation. Predictably, then, fragmentation or changes to natural habitat are factors that have detrimental effects on a population's well-being (Amos & Harwood, 1998). Indeed, the genetic diversity of the common toad has been shown to be related to habitat change. This was due to the variability of effective population sizes (Scribner *et al.*, 1997) between ponds, which was partly due to different aquatic breeding habitats (Scribner *et al.*,

2001). The current study is to investigate the underlying genetic mechanisms for the observed (Reading, 2001) reduction in female body condition in relation to increased annual temperatures. If the most fecund females produce the most fecund daughters then this can be interpreted as an evolutionary response to climate change by the common toad. If this is the case, then due to the variance in fitness of the females, the effective population size may become reduced. This is because, a reduction in fitness means a reduction in clutch size and disadvantages during sexual selection for those females who are less fecund. Subsequently, the already low effective population size may get further reduced (Scribner *et al.*, 1997); and, because heterozygosities are always lowered due to a decrease in effective population size, the heterozygosity-fitness correlations are made more significant (Ficetola *et al.*, 2010).

8. Summary

Upon completion of the current study a full molecular-marker based pedigree will be presented, which will be the first of its kind for amphibians. The research should allow an understanding of the underlying mechanisms causing adverse effects of environmental change to wildlife populations, furnishing us with important tools to prevent future extinctions.

9. References

- Amos, W. & Harwood, J. (1998) Factors affecting levels of genetic diversity in natural populations. *Philosophical Transactions of the Royal Society of London B Biological Sciences*, 353, 177-86.
- Beebee, T.J.C. (1995) Amphibian breeding and climate. *Nature*, 374, 219-220.
- Beever, E.A., Brussard, P.F. & Berger, J. (2003) Patterns of apparent extirpation among isolated populations of pikas (*Ochotona princeps*) in the great basin. *Journal of Mammalogy*, 84, 37-54.
- Blaustein, A.R., Belden, L.K., Olson, D.H., Green, D.M., Root, T.L. & Kiesecker, J.M. (2001) Amphibian breeding and climate change. *Conservation Biology*, 15, 1804-1809.
- Blomqvist, D., Pauliny, A., Larsson, M. & Flodin, L.-A. (2010) Trapped in the extinction vortex? Strong genetic effects in a declining vertebrate population. *BMC Evolutionary Biology*, 10, 33.
- Bradshaw, W.E. & Holzapfel, C.M. (2001) Genetic shift in photoperiodic response correlated with global warming. *Proceedings of the National Academy of Sciences of the United States of America*, 98, 14509-14511.

- Brede, E.G. & Beebee, T.J. (2004) Contrasting population structures in two sympatric anurans: Implications for species conservation. *Heredity*, 92, 110-7.
- Brede, E.G., Rowe, G., Trojanowski, J. & Beebee, T.J.C. (2001) Polymerase chain reaction primers for microsatellite loci in the common toad *Bufo bufo*. *Molecular Ecology Notes*, 1, 308-310.
- Calder, W.A. (2000) Diversity and convergence: Scaling for conservation, Oxford, UK, Oxford University Press.
- Castellano, S., Cucco, M., Giacoma, C. & Fox, S.F. (2004) Reproductive investment of female green toads (*Bufo viridis*). *Copeia*, 2004, 659-664.
- Charmantier, A., McCleery, R.H., Cole, L.R., Perrins, C., Kruuk, L.E.B. & Sheldon, B.C. (2008) Adaptive phenotypic plasticity in response to climate change in a wild bird population. *Science*, 320, 800-803.
- Clinton, H.C., Sadler, K.C. & Hazelwood, D.H. (1974) Geographic variation in litter size and onset of breeding in cottontails. *Journal of Wildlife Management*, 38, 473-481.
- Clutton-Brock, T.H., Grenfell, B.T., Coulson, T., Maccoll, A.D.C., Illius, A.W., Forchhammer, M.C., Wilson, K., Lindstrom, J., Crawley, M.J. & Albon, S.D. (2004) Population dynamics in soay sheep, Cambridge, UK, Cambridge University Press.
- Collen, B., Mcrae, L., Kothari, G., Mellor, R., Daniel, O., Greenwood, A., Amin, R., Holbrook, S. & Baillie, J.E.M. (2008) 2010 and beyond: Rising to the biodiversity challenge. World Wide Fund. Gland, Switzerland.
- Collingham, Y.C. & Huntley, B. (2000) Impacts of habitat fragmentation and patch size upon migration rates. *Ecological Applications*, 10, 131-144.
- Corn, P.S. (2003) Amphibian breeding and climate change: Importance of snow in the mountains. *Conservation Biology*, 17, 622-625.
- Ficetola, G.F., Garner, T.W.J., Wang, J.L. & De Bernardi, F. (2011) Rapid selection against inbreeding in a wild population of a rare frog. *Evolutionary Applications*, 4, 30-38.
- Fitzpatrick, J.L. & Evans, J.P. (2009) Reduced heterozygosity impairs sperm quality in endangered mammals. *Biology Letters*, 5, 320-323.
- Frankham, R., Ballou, J.D. & Briscoe, J.D.A. (2002) Introduction to conservation genetics, Cambridge, UK, Cambridge University Press.
- Gienapp, P., Teplitsky, C., Alho, J.S., Mills, J.A. & Merila, J. (2008) Climate change and evolution: Disentangling environmental and genetic responses. *Molecular Ecology*, 17, 167-178.
- Gomez-Mestre, I. & Tejedo, M. (2004) Contrasting patterns of quantitative and neutral genetic variation in locally adapted populations of the natterjack toad, *Bufo calamita*. *Evolution*, 58, 2343-2352.

- Grant, P.R. & Grant, B.R. (2002) Unpredictable evolution in a 30-year study of darwin's finches. *Science*, 296, 707-711.
- Hansson, B. & Westerberg, L. (2002) On the correlation between heterozygosity and fitness in natural populations. *Molecular Ecology*, 11, 2467-2474.
- Hildner, K.K. & Soule, M.E. (2004) Relationship between the energetic cost of burrowing and genetic variability among populations of the pocket gopher, *T. bottae*: Does physiological fitness correlate with genetic variability? *Journal of Experimental Biology*, 207, 2221-2227.
- Hitchings, S.P. & Beebee, T.J.C. (1998) Loss of genetic diversity and fitness in common toad (*Bufo bufo*) populations isolated by inimical habitat. *Journal of Evolutionary Biology*, 11, 269-283.
- Hopkins, W.A. (2007) Amphibians as models for studying environmental change. *ILAR Journal*, 48, 270-277.
- Hughes, L. (2000) Biological consequences of global warming: Is the signal already apparent? *Trends in Ecology & Evolution*, 15, 56-61.
- Jetz, W., Sekercioglu, C.H. & Bohning-Gaese, K. (2008) The worldwide variation in avian clutch size across species and space. *PLoS Biology*, 6, 2650-2657.
- Jones, O.R. & Wang, J. (2010) Molecular marker-based pedigrees for animal conservation biologists. *Animal Conservation*, 13, 26-34.
- Kawecki, T.J. & Ebert, D. (2004) Conceptual issues in local adaptation. *Ecology Letters*, 7, 1225-1241.
- Kraaijeveld-Smit, F.J.L., Griffiths, R.A., Moore, R.D. & Beebee, T.J.C. (2006) Captive breeding and the fitness of reintroduced species: A test of the responses to predators in a threatened amphibian. *Journal of Applied Ecology*, 43, 360-365.
- Merila, J., Kruuk, L.E.B. & Sheldon, B.C. (2001) Cryptic evolution in a wild bird population. *Nature*, 412, 76-79.
- Millenium Ecosystem Assessment. (2005) Ecosystems and human well-being: Biodiversity synthesis. World Resources Institute. Washington, DC, USA.
- Moss, R., Watson, A. & Ollason, J. (1982) Animal population dynamics, Bristol, UK, J.W. Arrowsmith Ltd.
- O'malley, K.G., Camara, M.D. & Banks, M.A. (2007) Candidate loci reveal genetic differentiation between temporally divergent migratory runs of chinook salmon (*Oncorhynchus tshawytscha*). *Molecular Ecology*, 16, 4930-4941.
- Parker, R., Melathopoulos, A.P., White, R., Pernal, S.F., Guarna, M.M. & Foster, L.J. (2010) Ecological adaptation of diverse honey bee (*Apis mellifera*) populations. *PLoS One*, 5, e11096.

Parmesan, C., Ryrholm, N., Stefanescu, C., Hill, J.K., Thomas, C.D., Descimon, H., Huntley, B., Kaila, L., Kullberg, J., Tammaru, T., Tennent, W.J., Thomas, J.A. & Warren, M. (1999) Poleward shifts in geographical ranges of butterfly species associated with regional warming. *Nature*, 399, 579-583.

Phillimore, A.B., Hadfield, J.D., Jones, O.R. & Smithers, R.J. (2010) Differences in spawning date between populations of common frog reveal local adaptation. *Proceedings of the National Academy of Sciences of the United States of America*, 107, 8292-8297.

Pounds, J.A., Bustamante, M.R., Coloma, L.A., Consuegra, J.A., Fogden, M.P.L., Foster, P.N., La Marca, E., Masters, K.L., Merino-Viteri, A., Puschendorf, R., Ron, S.R., Sanchez-Azofeifa, G.A., Still, C.J. & Young, B.E. (2006) Widespread amphibian extinctions from epidemic disease driven by global warming. *Nature*, 439, 161-167.

Przybylo, R., Sheldon, B.C. & Merila, J. (2000) Climatic effects on breeding and morphology: Evidence for phenotypic plasticity. *Journal of Animal Ecology*, 69, 395-403.

Raeymaekers, J.a.M., Van Houdt, J.K.J., Larmuseau, M.H.D., Geldof, S. & Volckaert, F.a.M. (2007) Divergent selection as revealed by p-st and qtl-based f-st in three-spined stickleback (*Gasterosteus aculeatus*) populations along a coastal-inland gradient. *Molecular Ecology*, 16, 891-905.

Reading, C.J. (1986) Egg-production in the common toad, *Bufo bufo*. *Journal of Zoology*, 208, 99-107.

Reading, C.J. (1998) The effect of winter temperatures on the timing of breeding activity in the common toad *Bufo bufo*. *Oecologia*, 117, 469-475.

Reading, C.J. (2001) Non-random pairing with respect to past breeding experience in the common toad (*Bufo bufo*). *Journal of Zoology*, 255, 511-518.

Reading, C.J. (2007) Linking global warming to amphibian declines through its effects on female body condition and survivorship. *Oecologia*, 151, 125-131.

Reading, C.J. & Clarke, R.T. (1995) The effects of density, rainfall and environmental-temperature on body condition and fecundity in the common toad, *Bufo bufo*. *Oecologia*, 102, 453-459.

Reading, C.J. & Clarke, R.T. (1999) Impacts of climate and density on the duration of the tadpole stage of the common toad *Bufo bufo*. *Oecologia*, 121, 310-315.

Reale, D., Berteaux, D., Mcadam, A.G. & Boutin, S. (2003) Lifetime selection on heritable life-history traits in a natural population of red squirrels. *Evolution*, 57, 2416-2423.

Ruiz-Lopez, M.J., Roldan, E.R.S., Espeso, G. & Gomendio, M. (2009) Pedigrees and microsatellites among endangered ungulates: What do they tell us? *Molecular Ecology*, 18, 1352-1364.

Scribner, K.T., Arntzen, J.W. & Burke, T. (1997) Effective number of breeding adults in *Bufo bufo* estimated from age-specific variation at minisatellite loci. *Molecular Ecology*, 6, 701-712.

- Scribner, K.T., Arntzen, J.W., Cruddace, N., Oldham, R.S. & Burke, T. (2001) Environmental correlates of toad abundance and population genetic diversity. *Biological Conservation*, 98, 201-210.
- Stuart, S.N., Chanson, J.S., Cox, N.A., Young, B.E., Rodrigues, A.S.L., Fischman, D.L. & Waller, R.W. (2004) Status and trends of amphibian declines and extinctions worldwide. *Science*, 306, 1783-1786.
- Tryjanowski, P., Rybacki, M. & Sparks, T. (2003) Changes in the first spawning dates of common frogs and common toads in western poland in 1978-2002. *Annales Zoologici Fennici*, 40, 459-464.
- Visser, M.E. (2008) Keeping up with a warming world; assessing the rate of adaptation to climate change. *Proceedings of the Royal Society B-Biological Sciences*, 275, 649-659.
- Warren, M.S., Hill, J.K., Thomas, J.A., Asher, J., Fox, R., Huntley, B., Roy, D.B., Telfer, M.G., Jeffcoate, S., Harding, P., Jeffcoate, G., Willis, S.G., Greatorex-Davies, J.N., Moss, D. & Thomas, C.D. (2001) Rapid responses of british butterflies to opposing forces of climate and habitat change. *Nature*, 414, 65-69.

Evaluation of Training Programmes Provided for the Academic Staff of Libyan Universities

Majda Elferjani and Les Ruddock , *School of the Built Environment, University of Salford*

Abstract:

This paper intends to address the key issues of the PhD research that aim to evaluate the training programmes provided for the academic staff of Libyan universities. The focus of this paper is the University of Al Fatah (as a case study area). The reason for selecting this university to participate in the study was the researcher has professional experience as a Lecturer at this university since 2004 and as Head of the Kindergarten Department since 2005. The researcher teaches the students in the subjects of political science and sociology. It has been found that, over last four years, the researcher did not receive any training programme. A sample of academic staff will be interviewed using a semi-structured technique, which will fall within the qualitative research paradigm .Semi-structured interviews will be the main method of data collection. The collection of supporting documentation will also be utilized for triangulation purposes in order to assess the reliability and validity of the training programmes.

The paper focuses on the Lecturers in the university, without any judgment by students or by employees. Thus the generalisation of the findings to institutions outside this study cannot be validated. This paper can support capacity building in training programmes in Libyan universities through the identification of needs, which is an important initial stage in any capacity building programme. This is an original approach to the evaluation of the status of universities' training programmes in Libya.

Keywords

Training programmes, higher education, universities, Libya

1. Introduction

Libya stretches along the northeast coast of Africa bordering Tunisia and Algeria on the west and Egypt on the east; to the south are the Sudan, Chad, and Niger. Much of the country lies within the Sahara, with a total area of 1.760million square kilometres and the coastline along the Mediterranean Sea being 1,955

kilometres in length. The population is about 6,461,454 million according to the World Fact Book (2010). During the course of history, at one time or another, Libya has been conquered and settled by Greeks, Turks, Romans, Arabs and Berbers. Libya was part of the Ottoman Turkish Empire from the middle of the 16th century until 1911. This was the Turks' last area of remaining empire along the North African coast. In a last minute bid for colonies undertaken in the 20th century the Italians took it from the Turks. From 1945 to 1951 Libya was under UN trusteeship. In December 1951 Libya became an independent nation. It became the United Libyan Kingdom. In 1969 a military-led coup overthrew the royal government and established the new Libyan Arab Republic. Now, the official name of Libya is the Great Socialist People's Libyan Arab Jamahiriya.

The Higher Education sector in Libya was founded after independence in 1951. The first College of Arts and Education was established in 1955 (which went on to form the base of the Libyan University in the city of Benghazi) and the number of students was 33 male students only. A further branch was established in Tripoli in 1957. (El-Hawat, 2006a). These were renamed Garyunis University and Al Fatah University, respectively, in 1962. Later on, in 1966, a Faculty of Agriculture was established. By 1967, the Libyan University witnessed further expansion as it annexed both the Faculty of Higher Technical Studies and the Higher Teachers' Training College. In 1970, the Faculty of Medicine was founded and in the same year, the Islamic University in Al-Bayda, was incorporated by the Libyan University under the name of the Faculty of Arabic Language and Islamic Studies. In 1972 the Faculty of Oil and Mining Engineering was founded which then moved in the late 1970s to the Brega Oil Terminal Complex. The number of universities and colleges developed and reached 14 universities with more than 300 scientific sections and departments in the academic year 2004-2005. (*Education, G. P. s. C. f. 2008, p.23*). Libyan universities since 1957 have passed through four stages in their history. Al.hawat Ashour, (2010). The first stage: The establishment and construction stage 1956-1968. The second stage: The response stage to the Libyan need for professionals, administration, culture, and economic activities 1970-1985.

The third stage: A stage of expansion and growth 1969-1985. The fourth stage: A stage comprising quality, specialization and dealing with regional and international issues 1985-to the present.

The Libyan Higher Education sector has undergone phenomenal expansion, especially noticeable in the development of institutions, where the number of universities has increased from one university (The Libyan University) in the academic year 1969/1970 with 13,417 students to 12 Universities in the academic year 2003/2004 as well as an increasing number of technical and medical higher institutes. The total number of students in the academic year 2004/2005 reached 254,456 and 11,928 staff members

(Higher Education Secretariat, 2006). Higher education graduates have increased to 13% of the whole population (General Census of People, 2006).

Training is usually considered as a contrastive concept to education, if not as its polar extreme. A classical although not consensual definition of education is adopted by UNICCO: "the organized and sustained instruction designed to communicate a combination of knowledge, skills and understanding valuable for all activities of life".

Training has itself a vast array of meanings. Traditionally it has been associated with apprenticeship (Winch and Clarke, 2008). Nowadays its meanings vary from teaching someone how to perform relatively simple tasks to preparing someone for new job challenges, but some commentators consider that "the differences between education and training have always been exaggerated and the most reputable training programmes are education as much as training" (Moura Castro & Oliveira, 1994).

Training began like any other human behaviour; it developed through history, where it was the training tool for staff development, with ways and methods of various scientific approaches consistent with the nature of developments that occurs through the ages. The first training for workers was in the workplace; they learned how to perform their business through training, and it seems that the first rules and regulations governing application have emerged, represented in the laws of Hammurabi, (an Iraqi who was concerned with craft skills), these laws affected the process of training in that period of time and were one of the methods used to train doctors and lawyers. Generally, the first school for training appeared in the United States (1818) which was called The Mechanical Institute of Ohio. At the end of the nineteenth century, it was officially recognized by those in U.S. industry that there was an urgent need for training programmes and several schools were established for this purpose. (Mogrobi, M. and Waddan., M., 2009).

After the industrial revolution and the consequent development of methodologies incorporating methods and ways of thinking, concepts such as globalisation and the market economy emerged. There is now a more urgent need for ICT skills to be developed in order to keep up with global expertise in this area. This is reflected in the growing interest shown by developing countries and states; their desire to improve the performance of individuals and administrative institutions. There is now a focus not just on training activity, but results.

2. The Need for the Research

The rapidly evolving world of technology, modern means of communication, and the globalization of the labour market; have introduced major changes in the patterns and methods of education and training in universities, where they have great impact in determining the level of human development. Nowadays there is massive expansion in Libyan universities (Alawat, 2006; Gannous & Aljoroushi, 2004). This expansion has been in quantity not in quality, thus there are a number of factors which make this study a valuable area to investigate, which are:

2.1. The Weak Libyan Higher Education System

Higher Education (HE) plays a key role in the arrangement of training and educating teachers because of the role of HE as a major provider of teacher training which impacts on the quality of the education system. Libya ranks 110th out of 111 countries providing HE. In addition, the Libyan Education System (LES) has failed to achieve its goals. Countries were studied on the overall quality of education provision. (Cited in Porter and Yergin, 2006).

In the HE system there is no appropriate body setting standards and planning for the future skills' requirements of the job market (Porter and Yergin, 2006; UNESCO Regional Bureau for Education in the Arab States, 2003). Agha and Hatuch (2006) recommended an urgent need to apply Total Quality Management (TQM) in education.

2.2. The Absence of Research in Libyan University Training Programmes

Training programmes in universities (TPU) are an important sector of the public education system in Libya. Unfortunately, the present research's literature survey has shown that there is very little research and literature available covering the problems and issues related to training programmes in Libya, particularly at HE level. (Saad Elzalitani, 2008).

It was decided during the meeting mandated by the Secretariat of the General People's Committee of Education to take action on the development of curricula in order to accommodate new developments in scientific and technical areas, as well as raising the efficiency of teachers, providing regular training programmes for them, and to take the necessary measures needed to use modern methods and technique. (AICIT, 14-16/12/2010).

2.3. Government Policy

Libya has a growing interest in providing the education and training programmes necessary in the preparation of people trained and qualified to meet the requirements of the plans and projects required for economic and social development and for the needs of the individual and society. Therefore, the education system in Libya has become the focus of the government's strategy in more recent years (El-Hawat, 1996 and 2003; Gannous, 1999). Accordingly, during the 1990s, a network of Public Higher Vocational Education and Training Colleges was set up. The Libyan authorities are acutely aware of the need to raise the quality and standards in universities. At the first Ordinary Meeting of the National Universities' Committee of the GPC for Education & Scientific Research held on 15 April 2010, the General Secretary announced that the forthcoming university academic year should be the year of quality in Libyan universities. Gibril Eljrushi, Dean of the Engineering Faculty at the 7th October University in Misurata, told University World News, that; the main aim of Libya's higher education strategy is to set up a knowledge-based Libyan society and to promote science-based industrial development. Eljrushi confirmed that among the strategy's numerous projects are the establishment of a National Authority for Scientific Research (NASR) and a Centre for Quality Assurance and Accreditation (CQAA).

3. Research Outline

3.1. Aim of the research

The main aim of this study is to develop a framework that identifies the barriers to implementing Training Programmes (TPs) for the academic staff in Libyan Universities (LUs).

To achieve this aim, the research will focus on the following objectives stated below.

3.2. Objectives

- To review the relevant literature on the concept of Training and Teaching Development Programmes for university academics around the world.
- To identify what tools of modern technology exist and which are required in Libyan Universities.
- To explore and study the barriers affecting the implementation of TPs in Libyan universities.
- To provide a practical framework for the decision makers to develop TPs at L

3.3. Research Questions

- a-** What are the barriers that affect TPs in Libyan Universities?
- b-** Why are there no appropriate TPs introduced for the academic staff in Libyan Universities?
- c-** To what extent can TPs be applied in Libyan universities?
- d-** How do these barriers affect the implementation of TPs in Libyan universities?

3.4. Expected Research Contribution

This research will provide an investigation on the subject of TPs in the context of the Libyan environment. The purpose of this research is to identify the factors affecting the TPs provided to the academic staff by the universities and to discover what issues arise from these programmes. There is a lack of empirical studies on TPs in LUs. Therefore, this research will add knowledge to this area. It will also contribute to the literature of TPs by identifying the key factors affecting the implementation of TPs in Libyan universities. As a result, at the end of this study the researcher will provide a framework which will show these factors and this framework could be used to remedy the problem of TPs in LUs.

4. Methodology of Study

Research methodology is the process followed by a researcher to achieve the aim and objectives of a particular study. It provides the basis to make informed decisions, step by step, about how the research should be conducted. Moreover, research methodology comprises several key elements that a researcher should consider when undertaking research, for instance, the overall research approach, data collection techniques and data analysis techniques (Collis and Hussey 2003).

4.1. Research Philosophy

The term ‘research philosophy’ relates to the development of knowledge and the nature of that knowledge. As stated by Saunders *et al.* (2003), Easterby-Smith *et al.* (2002, p.27) reasons why an understanding of philosophical issues is useful for the author is” *It can help in clarifying the research*

designed; also, it can enable avoiding going up too many blind alleys. In addition, it can help to identify and even create designs that may be outside his or her past experience. And it may also suggest how to adapt research designs according to the constraints of different subject knowledge structures”.

Many authors such as Remenyi *et al.* (1998), Esterby-Smith *et al.* (2002), Saunders *et al.* (2003) and Collins and Hussey (2003) have mentioned that there are two main research philosophies or paradigms: phenomenology (interpretivism) and positivism (Hussey and Hussey, 1997; Easterby-Smith *et al.*, 1991; Collis and Hussey, 2009)

In Table 1 Easterby-Smith *et al.* (2004, p.30) summarised the distinction between positivist and phenomenological philosophies.

Table 1: Contrasting implications of positivism and phenomenology, (Easterby-Smith *et al.*, 2004).

	Positivism	Phenomenology
The observer	Must be independent	Is part of what is being observed
Human interests	Should be irrelevant	Are the main drivers of science
Explanations	Must demonstrate causality	Aim to increase general understanding of the situation
Research progress through	Hypotheses and deduction	Gathering rich data from which ideas are induced
Concepts	Need to be operationalised so that they can be measured	Should incorporate stakeholder perspective
Units of analysis	Should be reduced to simple terms	May include the complexity of ‘whole’ situations
Generalisation through	Statistical probability	Theoretical abstraction
Sampling requires	Large numbers selected randomly	Small numbers of cases chosen for specific reason

The review of the literature relating to TPs will be conducted through library and internet research in which textbooks, journal articles, bulletins, newsletters, professional body publications, and seminar reports pertaining to the subject matter will be used. In particular, research in similar cultural contexts to Libya will be sought.

4.2. Research Approach

There are two main research approaches, the deductive and inductive approaches. Quantitative research is deductive in nature (deductive testing where the theory depends on the literature review, and from this the hypothesis is formed, ie, start general and end with the specific); it allows the researcher to first collect the data and then to generate hypotheses or propositions that can be tested quantitatively (Hussey and Hussey, 1997). While the inductive approach is often associated with qualitative research in which the researcher collects data and develops the theory as a result of data analysis (Saunders *et al.*, 2007). Inductive research builds up the theory and starts with the specific rather than generalities. Collis and Hussey (2003) discussed the philosophical assumptions that underpin the two main paradigms. Table 2 is adapted from their work.

Table 2: Assumption of the two main research approaches, Source: Collis and Hussey (2003).

Assumption	Questions	Quantitative	Qualitative
Ontological	<i>What is the nature of reality?</i>	Reality is <i>objective</i> and singular, apart from the researcher.	Reality is <i>subjective</i> and multiple as seen by participants in a study
Epistemological	<i>What is the relationship of the researcher to that research?</i>	Researcher is <i>independent</i> from that being researched.	Researcher interacts with that <i>being researched</i> .
Methodological	<i>What is the process of research?</i>	<i>Deductive process</i> Cause and effect static design-categories isolated before study Context-free generalisations leading to predication, explanation and understanding accurate and reliable data through validity and reliability.	<i>Inductive process</i> Mutual simultaneous shaping of factors. Context-bound emerging design-categories identified during research process patterns theories developed for understanding accurate and reliable data through verification.

Saunders *et al*, (2007) encouraged combining deductive and inductive approaches within the same piece of research. In this research, the researcher expects to incorporate the findings from the case studies into an existing theory (inductive approach).

4.3. Research Strategy

The aim of the research design is to satisfy the research aim and objectives. There are a number of research methodologies in social science which include: experiments, surveys, histories, analysis of archival information and case study research (Yin, 2003).. In case studies the researcher collects both primary and secondary data According to Yin (2009) three conditions can be used to select the appropriate strategy for research in the social science field. These are the type of research question posed the extent of control an investigator has over actual behavioural events and the degree of focus on contemporary as opposed to historical events. Table 3 shows these three conditions and how each one is linked to five main research strategies.

Table 3: Relevant situations for different research methods. Source: Yin (2009).

Method	Form of Research Question	Requires Control of Behavioural Events?	Focus on Contemporary Events
Experiment	How, Why?	Yes	Yes
Survey	Who, What, Where, How many, How much?	No	Yes
Archival analysis	Who, What, Where, How many, How much?	No	Yes/No
History	How, Why?	No	No
Case study	How, Why	No	Yes

4.4. Data Collection Methods

The method of data collection from respondents is the first step taken in any such study. Yin (2003) stated that there are many forms of data collection such as questionnaires, personal interviews, observational techniques and documentation. The aim and objectives of this research will be achieved by the collection of both primary and secondary data. This will involve three separate activities as follows: firstly, conducting a review of the literature; secondly, undertaking a piece of empirical study in Libya to collect data regarding managerial and academic staff attitudes, and finally, by investigating documentary evidence, to identify and analyse current barriers to TPs. A documentation review is used as a source of evidence to satisfy the requirements for research validity and reliability. The documents may include reports, memos, minutes of meetings, proposals, and newspaper articles.

Additionally, the researcher will conduct a pilot study to identify problems that might occur with the questions posed in the semi-structured interviews. The sample will include two different groups, the first group sample will comprise a number of senior and top managers at

Al Fatah University; this sample will be interviewed using a structured technique, which will fall within the qualitative research paradigm. The second group sample will consist of the academic staff at the University of Al Fatah, and this group will also be interviewed using a structured technique.

4.5. Data Analysis

The data collected from the case study organisations will be analysed according to suitable methods to be decided in advance of the data collection.

5. The Proposed Framework

A theoretical framework is a set of theories and models from the literature (Collis and Hussey, 2003). The framework will help the author to develop suitable TPs in LUs. In addition, the framework will draw attention to the relationship between the factors which need to be considered in order to understand the barriers that affect the implementation of TPs in LUs.

6. Conclusion

This paper address the key issues of the PhD research that aims to evaluate the training programmes provided for the academic staff of Libyan universities. This study has looked at the historical development of the HE system in Libya which is structured in four stages since the establishment of the first university in 1955 to the present day, along with an overview of the training programmes from the time when the laws of Hammurabi were introduced. After reviewing the literatures it can be seen that there is a deficiency in the research covering training programmes in the LUs. The Libyan government realise the importance of the higher education sector and has started to implement a new strategy to maintain and improve the higher education system. In addition, the aims and objective, research questions and contribution to knowledge was identified, together with the reasons or the research, namely the Weak Libyan Higher Education system, the absence of research in training programmes in Libyan Universities and Government policy. The research was methodology was discussed with the process followed by a researcher to achieve the aims and objectives of the study .The researcher expects to use an inductive approach by collecting data from the managerial and academic staff from the University of Al Fatah.

7. References

- AGHA, S., HATUCH, Z (2006). Quality Management in Vocational Education. Quality Conference. Tripoli-Libya.
- Alawat, M. A. (2006). The symposium of higher education and development in Alj
- COLLIS, J., Hussey R (2003). business research: a practical guide for undergraduate and postgraduate students, Palgrave amahiriya. Tripoli, World Centre for Studies andResearch of the Green Book. Macmillan.
- COLLIS, J., Hussey R (2009). business research: a practical guide for undergraduate and postgraduate students, Palgrave amahiriya. Tripoli, World Centre for Studies andResearch of the Green Book. Macmillan.
- Easterby-Smith M., T. R., et al. (2004). Management Research: An Introduction. London, SAGE Publications Ltd.
- Easterby-Smith M., T. R., et al. (2008). Management Research: An Introduction. London, SAGE Publications Ltd.
- Elzalitani, s. (2008). vocational education and training programmes in libyan higher education sector.

School of the Built Environment, Research Institute for the Built and Human Environment,. manchester, salford. PhD.

Gannous, S. M. a. and S. M. Aljoroushi (2004). A report on the statues of private universities and higher colleges in the eastern region. libya, The Secretariat of Services Affairs, The General People's Committee.

Gannous, S. M. E. (1999). Libya, the revolution: the social, political,economic_changes in thirty years, 1996-1999. Misrata, Aljamahiriya Publishing House.

General People's Committee for Education (2008). The Development of Education. Tripoli.

Ghanem S, Ed. (1977). The international encyclopaedia of higher education. London, J-M Jossey-Bass Publishers.

Hussey J, and Hussey R. (1997). Business research: a practical guide for undergraduate and_postgraduate students. london, Macmillan Press.

Mogrobi, M. and M. Waddan. (2009). Obstacles to harmonization between the outputs of education and vocational training needs and labour market conditions' Symposium on the native business owners to narrow the gap between the outputs of training and labor market needs. Ciro, Arab Labour Organization.

Moura Castro, C. B. J. B. O. (1994). Training and education, convergence between. In: T.N. Postlethwaite (ed.)

PORTER, M., E. & YERGIN, D. (2006). "National Economic Strategy: An Assessment of the Competitiveness of the Libyan Arab Jamahiriya."

Remenyi D., M. A. William B., et al. (1998). Doing Research in Business and Management'': An Introduction to process and Method. london, Sage Publications.

Saunders M., Lewis P., et al. (2003). Research Methods for Business Students. london, Financial Times Prentice Hall.

Saunders M., Lewis P., et al. (2007). Research Methods for Business Students. london, Financial Times Prentice Hall.

Saunders M., P. Lewis;, et al. (2000). Research Methods for Business Students. london, Financial Times Prentice Hall.

UNESCO, R. B. F. E. I. T. A. S. (2003). "Higher education in the Arab Region1998-2003."

Winch, C. and L. Clark (2008). Training, The Routledge International Encyclopedia of Education.

Yin, R. K. (2003). Case study Research: Design and Methods, Sage Publications.

Yin, R. K. (2009). case study research: Design and Methods, Sage Publications.

The Methodology of Identifying of the Factors of Organisational Conflict in the Libyan Cement Industry

Munira Elmagri and David Eaton, *School of the Built Environment, University of Salford*

Abstract

Recently organisations have become more complex and diverse in responding to globalisation and to internal and external changes, and this makes them more vulnerable to different types of organisational conflict. One survey showed that managers spend more than 25% of their work time dealing with conflict. Therefore, conflict within organisations has received considerable attention in academia and industry. However, there is a lack of empirical studies on subject of the factors causing interpersonal conflict in countries around the world and most of what has been written about it are theoretical studies. Moreover, research methodology is a key element in any thesis or dissertation. It refers to the choice and use of particular strategies and tools for data collection and analysis. According to this background, this paper will focus on determine an appropriate research philosophy and methodology for answering the main question of an ongoing doctoral research ‘what are the factors of interpersonal conflict in the Libyan cement industry’.

This paper could be useful for many researchers who are in the stage of identifying the research philosophy and methodology and this study could be used for many empirical studies on organisational conflict and its management.

Keywords

Organisational conflict, interpersonal conflict, conflict management, research methodology, research philosophy, cement industry, Libya.

1. Introduction

Research methodology is the most important part in any academic research, that because it helps the reader to understand the way by which the data are collected and analyzed. Therefore, this paper will focus on determine an appropriate research philosophy and methodology for an ongoing doctoral research

that aims to investigate and identify the factors of interpersonal conflict (which is a kind of organisational conflict) in the Libyan cement industry .

1.1. Background

Authors writing on organisational behaviour call conflict within organisations 'organisational conflict (OC)' which can take on any of several different forms, including intrapersonal, interpersonal, intergroup and inter-organisational conflicts. It can be noted that the prefix 'inter' means "between," whereas the prefix 'intra' means "within".

Intrapersonal conflict: this kind of conflict occurs within an individual because of actual or perceived pressures from incompatible goals or expectations (Schermerhorn, et al., 2005).

Interpersonal conflict (IpC): this is a conflict that occurs between two or more individuals. Many individual differences lead to interpersonal conflict, including personalities, culture, values, perceptions, and the other differences (Elsayed-Elkhouly, 1996). This research will concentrate on studying this kind of OC.

Intergroup conflict: this occurs between groups or teams in an organisation and it will lead to a competition between groups which must be managed carefully.

Interorganisational Conflict: this occurs between organisations and is most commonly thought of in terms of the competition and rivalry which characterises companies that operate in the same markets (Schermerhorn et al., 2005).

1.2. Justifications for Studying Interpersonal Conflict (IpC)

The purpose of choosing IpC and not any other OC is because individuals are the main element in any organisation and without them organisations cannot exist. Also, Newstrom, (2007) stated that IpC is a serious problem to many people because it deeply affects a person's emotions. Moreover, this type of conflict can spread rapidly among individuals within organisations and its negative outcome has a strong influence on the parties involved in the conflict if it is not controlled (Al-Nimr, 1994; Bader, 1988). Adomi & Anie (2006) mentioned that IpC involves a relationship in which a sequence of conditions and events moves toward aggressive behaviour and disorder if not properly managed. Due to these elements this research will focus on studying the factors causing IpC in the Libyan environment of cement industry.

1.3. The Libyan Cement Industry and the Research Problem

The Libyan cement industry has two companies: The Ahlia Cement Company (ACC) and the Libyan Cement Company (LCC). The Ahlia Cement Company was a public company, but in 2005 it changed to a private company as a share holding company and now it has six plants: El-Mergeb (in Al-Komes); Suk Elkamis (in Tripoli); Lebda (in Lebda); Zliten (in Zliten); a bags plant (in Al-Komes) and Alklata (in Tripoli) (ACC, 2009).

The Libyan Cement Company (LCC) was a public company, but in 2006 it changed to a private company as a share holding company. It started production with one plant, but now has four plants; Benghazi plant, Hawari plant, El-Fatayah plant and it has a plant for produces cement packaging in Benghazi city (LCC, 2009).

GPC, (2008) mentioned that the production of Libyan cement companies still does not cover the local Libyan market. Moreover, Alfaitori, (2004) has indicated that Libyan cement companies have suffered from the phenomenon of organisational conflict. Therefore, he suggested that the factors caused by all types of organisational conflict needed to be studied.

Libyan cement companies have consistently faced managerial, technical and financial problems which has lead to low productivity (IGB, 2001; Binsaoud, 2002). Based on the perceived relationship between productivity and conflict in organisations, this may be one of the managerial problems that has caused low productivity. Thus, the research problem has been identified in studying the factors causing IpC in the Libyan cement industry.

1.4. The Importance of the study

The importance of studying IpC and its factors originates from the importance of managing OC and from the fact that conflict within any organization is an inevitable and unavoidable occurrence and has a negative outcome on the individual and the organization, unless properly managed (Almusdy, 2007; Tjosvold, 2006; 2008). On the other hand, conflict has positive effects such as, it might lead to improved problem solving or decision- making, to the stimulation of creativity and may increase the productivity (Hellriegel & Slocum, 2004). This positive aspect of conflict depends on how it is controlled and managed (Adomi & Anie, 2006; Tjosvold, 2006; 2008). In addition, conflicts take up a lot of managers' time at all managerial levels (Luthans, 2008; Hellriegel and Slocum, 2007). This idea is supported by Hitt et al. (2006: p. 436) who stated that:

“One survey showed that managers spend approximately 25% of their time dealing with conflict. In some fields (such as hospital administration and management of municipal organizations), managers can spend as much as 50% of their time managing conflict. Managers rate conflict management as equal to or higher in importance than planning, communication, motivation, and decision making”.

Moreover, identifying the factors of any kind of OC is considered to be one of the most important topics to be investigated because these factors are considered to be one of the main stages in the process of conflict management (Hitt et al., 2006; Al-Rajhi, 2008). This led the author in (2001) to recommend that the factors causing IpC needed to be studied in Libyan organisations. This idea was supported by Alfaitori (2004) who suggested that factors of OC needed to be investigated in the Libyan cement industry in particular. Therefore, this research will focus on studying the factors of IpC in the Libyan cement industry.

1.5. Expected Contributions to Knowledge

This research intends to make academic and practical contributions. There is a lack of empirical studies on subject of the factors causing IpC in countries around the world and most studies have focused on managing IpC and OC. In addition, most of what have been written about the factors causing IpC are theoretical studies. Therefore, the main expected academic contribution to knowledge is to fill the gap in the literature on identifying the factors causing IpC by conducting an empirical study in the Libyan environment. The expected practical contributions are that this study would be helpful for many managers and could be used in many empirical studies on IpC and its management. Moreover, this study will provide recommendations to the administration of the cement industry in Libya for IpC reduction.

2. Research Methodology

Chandler (2006) defined methodology as a key element in any thesis or dissertation. Research methodology refers to the choice and use of particular strategies and tools for data collection and analysis. Hence, the research aim and objectives are the main factors that determine an appropriate research methodology and method. Therefore, research methodology is the systematic way a researcher uses to deal with the work undertaken using appropriate methods to collect and analyse data and to properly identify the issues to be discussed as well as the objectives of the research.

2.1 Research Aim and Objectives

As mentioned before the ongoing study aims to ‘Investigate and Identify the Factors causing IpC in the Libyan Cement Industry’. Thus, the objectives of this study are:

- To review and critically reflect on the relevant literature on the concept of IpC to understand the causal factors;
- To identify a list of these factors to use in the field study;
- To conduct an empirical study in the cement industry in Libya;
- To create a validated list of the factors causing IpC in the cement industry in Libya;
- To provide an explanation of these critical factors and their sources to provide recommendations to the administration of the cement industry in Libya for their reduction.

2.2 Research Questions

The research questions of this study are:

- What are the factors causing IpC in the Libyan cement industry?
- Why do these factors exist in the Libyan cement industry?
- How do these factors affect IpC in the Libyan cement industry?

2.3 Research Philosophy

In the early stages of research methodology, a researcher will often choose a particular philosophy that will be used as a foundation for the study and all research processes will be built based upon that. Sutrisna (2009) stated that the philosophical stance of the researcher will strongly influence the reasoning of the research and thus will influence both the data collection and hence the data analysis. There is no definite rule as to which philosophy to select when doing research. It all depends on the nature and scope of the thesis, the source of the data, the research questions or hypotheses, the constraints and the overall research aim and objectives.

From various philosophical branches there are two common branches of philosophy; one of them called ontology and the other is epistemology (Ibid). Most researchers find it difficult to comprehend these two areas of philosophy. However, this paper will try to put forward a simple explanation for these two branches of philosophy.

2.3.1 Ontology Philosophy

Ontology is a study of conceptions of reality and the nature of being. Sexton, (2007) presents in his model of research approaches a continuum which shows that ontology could fall under either the realism or idealism aspects of research knowledge. According to Aouad (2009), realism is a commonly experienced external reality with a predetermined nature and structure. On the other hand, idealism is an unknowable reality perceived in different ways by individuals (Ibid).

Sutrisna (2009) and Bryman (2007) divided research ontology into two common positions, namely objectivism and constructivism. According to Bryman (2007) objectivism is an ontological position that asserts that phenomena and their meanings have an existence that is independent from actors. However, constructivism is an alternative ontological position which asserts that phenomena and their meanings are continually being accomplished by the actors (Sutrisna, 2009). Therefore, objectivists believe that there is only one reality experienced the same way by each and every one of us whilst constructivists believe that reality is constructed by each and every of us differently (Ibid). Hence, each person has their own view of reality and there are multiple realities.

Based on the above discussion, it can be argued that ontology philosophy could be divided into two main positions which are realism or idealism (Aouad, 2009; Sexton, 2007). Realism means that reality is one objective as seen by different participants. On the other hand, idealism means that reality is constructed by each participant differently, thereby it can be stressed that idealism is multiple as seen by participants.

This study aims to identify the factors causing IpC from the point of view of the study participants. Therefore, the ontology philosophy of this research is idealism which refers to the fact that reality is constructive and multiple as seen by different participants in the Libyan cement industry.

2.3.2 Epistemology Philosophy

Epistemology is one of the major branches of philosophy. It is a general set of assumptions about how we know what we know (Aouad, 2009). It is the branch of philosophy that is concerned with what we accept as valid knowledge (Collis & Hussey, 2009). Sutrisna (2009: 5) has explained that “*epistemology looks at the theory of knowledge, especially with regard to its methods, ‘validation’ and the possible ways of gaining knowledge in the assumed reality*”. He has divided the epistemological philosophy into common positions; positivism and interpretivism. Easterby-Smith et al. (2008: 57) described positivism as “*the social world exists externally, and that its properties should be measured through objective methods rather than being inferred subjectively through sensation, reflection or intuition*”. Additionally, Milliken

(2001) remarked that the key idea of positivism is that the social world exists through objective measures, instead of being inferred subjectively through sensation or intuition.

On the other hand, Easterby-Smith et al. (2008 p58) described interpretivism (constructionism) as something which “*focuses on the way that people make sense of the world, especially through sharing their experiences with others via the medium of language*”. Collis & Hussey (2009) have all asserted that the interpretivist position refers to the subjective aspects of human activity by focusing on the meaning rather than the measurement of social phenomena.

Based on the nature of this research which is focusing on meaning rather than measurement; and because the researcher wants to gather rich information from the point of view of the study participants, therefore the interpretivism position will be selected as the research epistemology.

2.4 Reasoning of the Research

The reasoning of the research refers to the logic of the research which influences the data collection of the research and the data analysis. In the acquisition of new knowledge there are two ways of undertaking the reasoning of the research, namely inductive and deductive research (Sutrisna, 2009). According to Hyde (2000), deductive research is a theory testing process which starts with an established theory, then formulates a hypothesis and seeks to observe whether the theory applies to specific instances. On the other hand, inductive reasoning is generally an inquiry to understand a social or human problem from multiple perspectives (Yin, 1994). Inductive research is used when a researcher wishes to develop a theory as a result of data analysis (Saunders et al., 2003). Deductive reasoning is theory testing and goes from the general to the specific whilst inductive reasoning is theory building and goes from the specific to the general. Inductive research is often associated with interpretivist philosophy while deductive research is often associated with positivist philosophy.

The research philosophy and the nature of this study is not theory testing, it is theory building and the researcher intends to develop a theory inductively from data collection and analysis. Therefore, inductive research is a suitable for this research.

2.5 Research Approach

There are two main types of research approach in social science, namely quantitative and qualitative. A quantitative approach is often associated with the positivism philosophy which concerns counts and

measures of things (Easterby-Smith et al., 2008). Moreover, quantitative research is concerned with questions such as: How much? How often? How many? (Gummesson, 2000).

On the other hand, qualitative research usually implies an emphasis on processes and meanings rather than numbers (Bryman, 2007). Thus, a qualitative method is more constructive and reflects on perceptions in order to gain an understanding of social and human activities (Hussey & Hussey, 1997). Therefore, Sutrisna (2009) and Easterby-Smith et al. (2008) confirmed that a qualitative method emerges from interpretivism and it is based on the assumption that there is no singular objective reality and hence the observed reality will be related to the researcher's interaction with the problem.

This research focuses on meaning rather than numbers. Hence, qualitative methods are the most suitable methods to be used in this study.

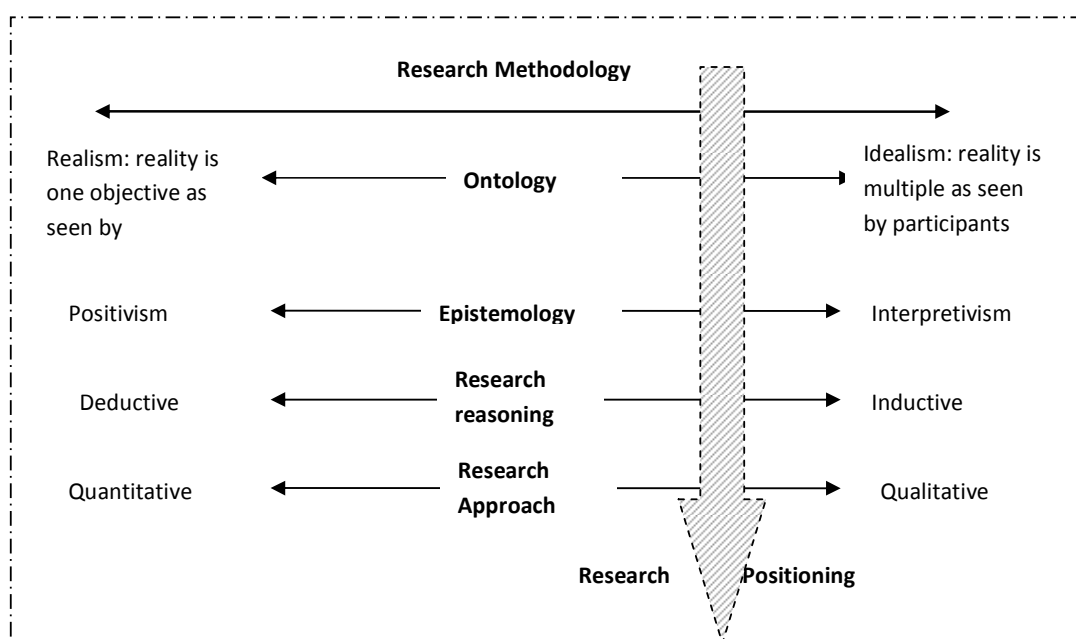

Figure 1: Research positioning within the research methodology

The idea has been adopted from Sutrisna (2009).

In summary, the nature of this study is to contribute to establishing a philosophical research base within the ontological stand of idealism which holds the assumption that reality is multiple subjective, because reality is constructed by each person differently in the social environment. Interpretivist philosophy is selected as a research epistemology which refers to the subjective aspects of human activity by focusing

on the meaning rather than the measurement of social phenomena. Hence, inductive reasoning and the qualitative approach are the most suitable for this study's research philosophy.

2.6 Research Strategy

Saunders et al. (2007) defined the research strategy as a plan of how to answer the research questions which will satisfy the research objectives. Yin (2009) listed five different types of research strategies, summarised in Table 1. Yin (2009) also pointed out three conditions which can be used to select the appropriate strategy for the research:

- the type of research question;
- the control of the researcher over behavioural events;
- the degree of focus on contemporary as opposed to historical events.

Table 1: Relevant situations for different strategies

Strategy	Form of Research Question	Requires control of Behavioural Events?	Focus on Contemporary Events
Experiment	How, Why?	Yes	Yes
Survey	Who, What, Where, How many, How much?	No	Yes
Archival analysis	Who, What, Where, How many, How much?	No	Yes/No
History	How, Why?	No	No
Case study	How, Why?	No	Yes

Source (Yin (2009, p8))

Yin (2003; 2009) indicated that the case study is an appropriate strategy when 'how' or 'why' questions are being posed. This allows the researcher to determine not only what happened but also why it happened. He also recommended a case study strategy when the researcher has little control over the events and when the focus is on contemporary events. This research will answer the research questions:

what are the factors causing IpC in the Libyan cement industry? Why do these factors exist? How do these factors affect IpC in this industry? The event is contemporary and the researcher has no control over this phenomenon. Therefore, the case study strategy is suitable for this research. Yin, (2009, p18) defined a case study as “an empirical inquiry that investigates a contemporary phenomenon in depth and within its real-life context, especially when the boundaries between phenomenon and context are not clearly evident”. In addition, many researchers like Saunders et al. (2007); Velde et al. (2004) and Amaratunga (2002) confirmed that the case study is appropriate if the researcher wishes to gain rich descriptions and deep understanding of the context; it is a worthwhile way of exploring existing theory and will enable the researcher to investigate real life which can provide powerful insights. Moreover, one of the strengths of the case study strategy is that it allows the researcher to use a variety of sources and a variety of types of data as part of the investigation.

Based on the above arguments, the case study has been adopted because it is the most appropriate research strategy for this research.

Case studies can be conducted in one organisation (a single case study) or in more than one organisation (multiple case studies). In this research, a single case study method will be chosen. The main reason for conducting a single case study is the researcher wants to gather deep understanding and rich information from the participants who work in the Libyan Cement Company. Additionally, the Libyan Cement Company (LCC) covers approximately 40% of the cement industry in Libya (as mentioned, the Libyan cement industry has two companies: ACC which has six plants and LCC which has four plants).

The single case study strategy has two types of design, a single holistic case study which involves a single unit of analysis and a single embedded case study that involves multiple units of analysis (Yin, 2009). In this study, the single embedded case study will be selected. This will involve multiple realities at senior management, middle and shop floor management level.

2.7 Data Collection

Data within a case study can be collected from secondary or primary sources or both of them. In this study both of them will be used. Secondary data refers to information which already exists; for example: archival records, company documentation, publications (books, articles, etc) and annual reports, and may be available in hard copy form or on the internet. Many scholars like Ghauri & Gronhaug, (2005) and Churchill, (1999) recommend that all research should start with secondary data sources. This research has

used secondary data (literature review) to understand and develop the researcher's knowledge about the concept of IpC. This has helped the researcher to provide a list of the factors of IpC to use in the field work.

In this research, a data triangulation approach will be adopted by using a variety of data sources such as interviews, direct observation (primary data), documents and archival records (secondary data).

Collis & Hussey (2003) stated that interviews may be face-to-face, voice-to-voice or screen-to-screen; conducted with individuals or with a group of individuals. Moreover, according to Easterby-Smith et al. (2008) there are three types of face-to-face interviews. These are unstructured, structured and semi-structured interviews. In this research, the researcher will use face-to-face semi-structured interviews as the main method of data collection as well as documentations and archival records and direct observations as other sources of evidence to enhance the research validity and reliability.

2.8 Data Analysis

The main challenge to qualitative data analysis is that how the huge data which are conducting from different sources, such as interviews, documentation, archival records and direct observation can be summarised and structured to arrive at meaningful conclusions. However, there are two main methods of analysing qualitative data; quantifying methods and non-quantifying methods (Collis and Hussey, 2009). *Quantifying methods* use when the user has adopted mixed methodologies both qualitative and quantitative data collection. They have divided quantifying methods into:

- Informal methods: researcher often quantify data informally in the process of reducing or examining data such things as repetitive or patterned behaviours;
- Formal methods: researchers can quantify data formally by using content analysis or repertory grid technique.

On the other hand, *non-quantifying methods* are used when researcher adopts an interpretivist (phenomenological) approach. They have involved five methods:

- General analytical procedure: Data can be analysed through coding, summarising, categorising and identifying patterns or themes;
- Cognitive mapping: which is used to structure, analyse and make sense of written or verbal accounts of problems and this technique attempts to extend personal construct theory;

- Data displays: they are visual formats that present information systematically and the researcher can draw valid conclusions and take needed action (Miles and Huberman, 1994), and displays can be by networks or matrices;
- Grounded theory: it is used where no preconceived theoretical framework exists;
- Quasi-judicial methods: they are drawn from the legal profession and involve applying rational argument to interpret empirical evidence.

This research lies in the realm of interpretivist philosophy which focuses on meaning rather than numbers and will not use mixed methodologies. Therefore, the data analysis lies under non-quantifying methods and the data will be analysed by using general analytical procedure and a software package (NVivo) will be used for managing the data collection.

3. Conclusion

This paper would be useful for many researchers especially who are in the early stage of the study that because it has attempted to simplify and clarify the most complex issues among research methodology like; ontology, epistemology and the reasoning of the research (research logic). Next will be presented a brief explanation for these complex issues as a result of this paper as following:

Research philosophy holds two common branches; ontology and epistemology. *Ontology philosophy* is about ‘what is the nature of reality?’ which is fall under the knowledge of realism or idealism. Reality based on *realism* assumption is **one** objective as seen by different participants, while it is **multiple** as seen by participants on *idealism* assumption.

Epistemology philosophy is about ‘How do we know the reality?’ which divides in two positions; positivism and interpretivism. *Positivism* indicates that reality is obtained through the **measurement** of social phenomena whereas *interpretivism* position asserts that reality is reached from the **meaning** of aspects of human activity.

There are two ways of undertaking the *logic (reasoning)* of the research, namely deductive and inductive. *Deductive* reasoning is **theory testing** and goes from the general to the specific while *inductive* reasoning is **theory building** and goes from the specific to the general.

The ongoing doctoral research which aims to identify the factors of IpC in the Libyan cement industry is selected idealism position as ontology philosophy and interpretivist position for epistemology philosophy. Inductive reasoning, qualitative approach, a single embedded case study and a data triangulation approach are found as the most suitable for this study and the data will be analysed by using a general analytical procedure through using a software package (NVivo).

4. References

- ACC (Ahlia Cement Company), (2009). *Introduction about Ahlia Cement Company*. [Online] Available at: <<http://www.ahliacement.ly/Links/Introduce.html>> [Accessed 28 May 2009].
- Adomi, E. E. and Anie, S. O., (2006). Conflict management in Nigerian university libraries. *Library Management*, 27(8), pp.520-530.
- Almusdy, A. A., (2007). Factors for selection of strategies to confront conflict. *Scientific Journal of Economics and Trade*, 1(1), pp.1-55.
- Al-Nimr, S. M., (1994). Organization Conflict: Its Factors and Management Techniques. *Journal of King Abdulaziz University: Economics and Management*, 7(1), pp.37-91.
- Al-Otaibi, A. B., (2006). *Organizational conflict and ways of treatment*. MA. Naif Arab University. [Online] Available at: <<http://www.nauss.edu.sa/Ar/DigitalLibrary/ScientificTheses/>> [Accessed 28 May 2009].
- Al-Rajhi, H. N., (2008). *Roles of organizational politics in the management of organizational conflicts*. PhD thesis. Naif Arab University. [online] Available at: <<http://www.nauss.edu.sa/Ar/DigitalLibrary/ScientificTheses/Pages/default.aspx>> [Accessed 21 May2009].
- Alfajori, F. M., (2004). *The Organization Conflict & Its Relation with the Organization Commitment in Libyan Industrial Organizations*. MBA. Benghazi: University of Garyounis. (unpublished).
- Amaratunga, D., et al., (2002). Quantitative and qualitative research in the built environment: application of "mixed" research approach'. *Work Study*, 51(1), pp. 17-31.
- Aouad, G., (2009). *PhD Workshop: How to succeed in doing a PhD: personal experiences*. Postgraduate research workshop. 10 March 2009. University of Salford. UK.
- Bader, H. A., (1988). *Organization Behaviour*. Kuwait: Dar Alkalam.
- Binsaoud, R., (2002). *Evaluate Economic Performance of the Cement Industry*. MBA dissertation. Benghazi: University of Garyouni. (unpublished)

- Brotherton, B., (1999). Towards a definitive view of the nature of hospitality and hospitality management. *International Journal of Contemporary Hospitality Management*, 11(4), pp. 165-173.
- Bryman, A. and Bell E., (2007). *Business Research Methods*. Oxford: Oxford University Press.
- Burke, M. E., (2007). Making choices: research paradigms and information management. *Library Review*, 56(6), pp. 4-12.
- Chandler, D., (2006). Writing a Dissertation. [online] Available at: <<http://www.aber.ac.uk/media/Modules/dissertation.html#J>> [Accessed 18 April 2009].
- Churchill, G. A., (1999). *Marketing Research: Methodological Foundations*. 7th ed. Dryden Press.
- Collis, J. and Hussey, R., (2009). *Business research: a practical guide for undergraduate and postgraduate students*. Palgrave Macmillan Publishing.
- Collis, J. and Hussey, R., (2003). *Business research: a practical guide for undergraduate and postgraduate students*. Palgrave Macmillan Publishing.
- Denscombe, M., (2003). *The Good Research Guide for small-scale social research projects*. 2nd ed, Maidenhead: Open University Press.
- Easterby-Smith M., Thorpe R. and Lowe A., (2008). *Management research*. 3rd ed. London: Sage.
- Elmagri, M. I., (2001). *Strategies of Organisational Conflict Management And Their Relations With Conflict Intensity, Constructive Conflict and Effectiveness of Management in Libyan Banking*. MBA dissertation. Benghazi: University of Garyouni. (unpubiished)
- Elsayed-Elkhouly, S. M., (1996). Styles of Handling Personal Conflict in Egypt. United States, Africa, and the Gulf States. *Cross Cultural Management: An International Journal*, 3(1), pp. 20-32.
- Ghuri, N. and Gronhaug, K., (2005). *Research methods in business studies: A practical guide*. 5th ed. New York: Prentice Hall.
- GPC, (The General People's Committee) (2008). Meeting of the General People's Committee no 923 to assess the general situation of the availability of cement on the domestic market on 19-1-2008 in Tripoli. [online] Available at: <http://www.gpc.gov.ly/html/show_news2.php?value=923> [Accessed 25 March 2009].
- Gummesson, E., (2000). *Qualitative methods in management research*. 2nd ed. London: Sage.
- Hellriegel, D. and Slocum, J. W., (2004). *Organizational Behavior*. 10th ed, Cincinnati, Ohio : South-Western.
- Hellriegel, D., et al., (2007). *Organizational Behavior*. 11th ed. Mason, Ohio: Thomson/South-Western.

Hellriegel, D., et al., (1992). *Organizational Behavior*. Ohio: South-Western College Publishing.

Hitt, M. A., et al., (2006). *Organizational Behavior: a strategic approach*. Hoboken: John Wiley.

Hussey, J. and Hussey, R., (1997). *Business research: a practical guide for undergraduate and postgraduate students*. Basingstoke, Macmillan.

Hyde, K., (2000). Recognising deductive processes in qualitative research *Qualitative Market Research. International Journal*, 3(2), pp. 82-90.

IGB, (Industrial General Board), (2001). *Study the managerial and technical situation for Libyan Cement Industry from 1-7-2001 to 15-7-2001*, Industrial General Board.

LCC (Libyan Cement Company) (2008), Introduction about Libyan Cement Company. [Online] Available at: <<http://www.libyancement.com>> [Accessed on 28 May 2008].

Luthans, F., (2008). *Organizational Behavior*. Boston; London: McGraw-Hill.

Milliken, J., (2001). Qualitative research and marketing management. *Management Decision*, 39(1), pp. 1-9.

Nelson, D. L. and Quick, J. C., (2006). *Organizational Behavior : foundations, Realities, and Challenges*. 5th ed, Mason; Ohio : Thomson/South-Western.

Newstrom, J. W., (2007). *Organizational Behavior: Human Behavior at Work*. 12th ed. McGraw-Hill.

Rahim, M. A., (2002). Toward A Theory of Managing Organizational Conflict. *The international Journal of Conflict Management*, 13(3), pp. 206-235.

Robbins, S. P., (2007). *Organization theory*. 12th ed, Upper Saddle River: Prentice Hall

Saunders, M., et al., (2003). *Research methods for business students*. 3rd ed. Pearson Education Ltd.

Saunders, M., et al., (2007). *Research methods for business students*. 4th ed. Pearson Education Ltd.

Schermerhorn, J. R., et al., (2005). *Organizational Behaviour*. 9th ed. New York: John Wiley & Sons Inc.

Sexton, M., (2007). *PhD Workshop: Axiological purposes, ontological cages and epistemological keys*. Postgraduate research workshop, March 2007, Salford. University of Salford.

Strauss A. and Corbin J., (1998). *Basic of qualitative research: techniques and procedure for developing ground theory*. 2nd ed. Sage.

Sutrisna, M., (2009). *PhD Workshop: Reserch Methodology in Doctoral Research: Understanding the Meaning of Conducting Qualitative Research*. ARCOM doctoral workshop, Tuesday 12 May 2009, Liverpool John Moores University.

Tjosvold, D., (2006). Defining Conflict and Making Choices about Its Management: Lighting the Dark Side of Organizational Life. *International Journal of Conflict Management*, 17(2), pp. 87- 95.

Tjosvold, D., (2008). The conflict-positive organization: it depends upon us. *Journal of Organizational Behavior*, 29(1), pp. 19-28.

Yin, R. K., (1994). *Case Study Research Design and Methods*. 2nd ed. Sage.

Yin, R. K., (2003). *Case Study Research Design and Methods*. 3rd ed. Sage.

Yin, R. K., (2009). *Case Study Research: Design and Methods*. 4th ed. Sage.

Preliminary assessment of the food control systems in Libya

Nagat A Elmsallati, University of Salford

Abstract

Effective national food control systems are essential for food safety; ensuring consumer protection and international trade. However, in Libya food control systems are unable to ensure an adequate supply of safe food for domestic consumers or meet international sanitary and phytosanitary requirements for food exports. Increased concerns over food safety have induced developing countries to build a solid national food-safety system. Nevertheless, in this paper the Literature /document review had been used to assess the status of the food control systems in Libya. However, this paper concludes that the food control system in Libya shares many ministries and departments, with a lack of clarity in their roles. The coordination between relevant institutions is weak; fragmented and less sophisticated. Also the inspection systems focus on control of the final product. Progress is being made but there is evidence of some weakness where additional efforts may be needed. The paper focuses on the major tool of food law which is food control, without any judgment on food legislation and thus the generalisation of the finding outside of this topic cannot be validated. However the paper findings appear to be intuitively generalisable beyond the subject topic.

This paper can support capacity building in food control systems in Libya by identification of needs, which is an important initial stage in any capacity building programme. This is an original approach to evaluation of the status of food control systems in Libya

Keywords

Food Safety, international trade, food control, Libya

1. Introduction

Food safety has become an issue of major concern in whole the world, due in part to significant incident of microbiological and chemical contamination of foodstuffs. Threats such as salmonella, mycotoxins, bovine spongiform encephalopathy (BSE), avian flu, dioxin and residues from antibiotics have affected many coun-

tries. These, together with the rapid globalization of food production and trade, have increased the potential likelihood of international incidents involving foodborne diseases (Beulens et al. 2005).

According to World Health Organization 2700 million children dying of diarrhoea due to poor quality and unsafe food and water supplies in China at 1990. Also in USA at 1999 a 76 million cases of foodborne illnesses was reported (WHO, 1999). It is obvious here that food safety can have fatal and effects in both developing and developed countries. Hence food control is essentially a mandatory activity to protect consumer health as well as prevention of fraud.

2. Food Safety Keenness

The main reason behind the difference in awareness and receptiveness in food safety between developing countries like Libya and developed countries like USA or England for instance is the existence of food safety panic. In these developed countries highly publicised food scares and the rising number of food poisoning cases. In this regard the Centers for Disease Control and Prevention in USA (CDC) estimates that there are 325,000 hospitalizations and 5,000 deaths related to foodborne diseases each year (CDC, 2005) the same with UK where a study by Wheeler et al., shows that the scale of infectious intestinal disease in England is large, with an estimated 9.4 million cases occurring in the community annually (Wheeler et al., 1999). Consequently, this is rise of consumer phobia that forces a government to implement and maintain an effective food control system. This is probably what has led to the development of food safety system like Hazard Analysis and Critical Control Point (HACCP) in these developed countries. However, the number of cases of formally notified food poisoning cases in developed countries is much higher than in the developing countries like Libya. This might relate more to the difference in the reporting system of the theses countries than to anything else (FAO/WHO, 2002). The poor quality and availability of statistics in Libya could prevent any consumer concern form appearance. However, it could be that Libya has not observed any major increase in mortality due to food-borne diseases, as seen in Europe as UK.

3. What is Food Control

Food control is a very complex series of measures; it is all measures necessary to ensure the safety and wholesomeness of food during the chain of production to Consumption. These measures can be chemical

measures; physical measures and microbiological measures. It includes control of imports and exports of food and food related items; premise inspection; control of distribution channels and implementation and development of Legislations and Standards. However, According to the Food and Agriculture Organization of the United Nations, food control is defined as “a number of activities to provide consumer protection and ensure that all foods provided for human consumption are safe, wholesome, conform to safety and quality requirements, and are honestly and accurately labelled as prescribed by law” (FAO, 2007).

4. Aim of Food Control

Different countries will have different aims and objectives for their food control system convey their exact national situation and requirements (FAO, 2007). While the general purpose should be to ensure safe food for consumers, this may be expressed in different ways. The common objectives to be met are:

- To ensure the production of safe, wholesome and good quality.
- To identify problems, for example, sources of contamination.
- To satisfy customers and minimize complaints.
- To ensure compliance with specific regulations and standards.

However, this paper provides an opportunity for the Authority competent in food safety in Libya to over requirements for effective food control systems and to find strategies to make them priorities in the country. Nonetheless, evaluation of food control system is a routine exercise, which governments must consider it, which, unfortunately, they rarely do in developing country.

5. Objectives

The objectives of this study have been carried out to:

- Investigate background information on National food control system.
- Suggest recommendations for the improvement of food control system.

6. Approach

To achieve these objectives, the methodology that had been used to assess the status of the food control systems in Libya is literature review covering national and international reports; Codex manuals; journal articles and electronic data.

7. Discussion

A number of food threats that have occurred in Libya, despite the fact that Libya have adequate disease surveillance in place in which common food borne diseases are included (FAO/WHO, 2005). Considerable progress has been made in recent years in improving the general food safety infrastructure in this country, but foodborn disease surveillance does not exist (FAO/WHO, 2005). However, much remains to be done in the field of food safety, including an adjustment of national food safety priorities to also deal with specific food pathogens. Nevertheless, The Libya Ministry of Health reported the number of food poisoning cases registered in hospitals for 2001-2004 as shown in Table 1(FAO/WHO, 2005).

Year	Number of Cases
2001	297
2002	278
2003	129
2004	779

Table 1. Food Poisoning Cases, Libya (source: FAO/WHO, 2005)

8. Overview of the Libyan food control system

Food safety and quality control system in Libya is very similar to that in the rest of the world before the HACCP concept was developed, The style of methods adopted for safety and quality control systems were a quality control inspectors usually selected samples by choosing elementary units in such a way that each unit in the population has an equal chance of being selected. The samples were then assessed and certified on the extent of conformity to the approved standards. Samples that conform to standards

were accepted and distribute others are discarded (LNCSM, 2007). However, Food control system in Libya is based on the Health Law No. 106 and Standards Law No. 5 which prohibit the distribution and selling of fraudulent and unsafe foods and of food not compliant with the standards issued by the National Centre for Standardization and Metrology (Law No. 5, 1990), (Law No. 106, 1973). Whereas, food control activities are multi-sectoral however, the main coordination role in that area is carried out by the ministry of Health and environment; the ministry of Agriculture; Livestock and Marine. The Libyan national centre for standardization and metrology in addition to its role in food control, have the main responsibility for food safety regulations and standards in Libya (Law No. 5, 1990). It worth to say that national standards are represents as the framework for food control (Law No. 22, 1989).

The food control programs in Libya work through two approaches: inspection and legislations. There is a strong attention in establishing potential good hygienic program in the food industry in Libya under the influence of free trading with the intention of many countries in the region to join the World Trade Organization (WTO) and to facilitate trade between Libya and other countries, and to avoid any trade barrier in future (FAO, 2008).

9. National Centre for Food and Drug Control

The National Centre for Food and Drug Control appears as one of the important places for participation in the area of food control. It was established as the specialized health authority. In addition to controlling and inspection of food and feed it is responsible for the safety of food supplies with over 12 000 samples analysed annually. Some analyses have to be carried out outside the centre's laboratory. As well as it is responsible for accepting or rejecting any important food consignments (WHO, 2006). The Centre also has the authority to monitor and inspect all food production, distribution and display outlets. In 2003, the Centre inspected 9,305 imported food items. A total of 220 shipments were rejected and about 19,131 samples were analyzed. Additionally, the Centre has conducted a total of 2,310 field visits to the domestic market, including manufacturers, schools, wholesale and retail outlets, restaurants and slaughterhouses (FAO/WHO, 2005).

10. Food control and inspection route

As mention above the reference always the national standards which are represents as the framework for food control. However, although Libya is not a member of the WTO yet, it does have strict specifications for the control of all food products and feed. Food control carry out first by applied the national standards. In the absence of a national standard for a certain product the following sequence has been applied:

The International Standards (ISO);

The Codex Alimentarius Commission Standards;

Arabic standards issued by the Arab Industrial Development and Mining Organisation (AIDMO);

Other regional standards;

African regional standards do not require commitment by Libya. Nevertheless, when the global commodity is received, the exports are checked against required specifications. Recently, the General Public Committee of Libya established a National Codex Committee and nominated the National Centre for Standardization and Metrology as the focal contact point for Codex matters. As well Consumer Protection Associations are members of the National Codex Committee and of all its technical committees. Recently, a new decision has been published to establish a High Council for Consumer Protection (F.L.I.P., 2005).

11. Law Enforcement

The enforcement body which is responsible for achieving all food safety objectives are Municipal Guard; employees of the Centre of Standardization and Metrology and National Centre for Food and Drug Control. However, the most inspectors in Libya are public health inspectors who have completed secondary school and attended a multi-year course in public health inspection with limited specific training in food inspection. In the field of food control, inadequately trained staff could lead to inadequately law enforcement.

To obtain adequate and effective food safety and food control in Libya under the Libya's future free trade agreements with the European community; Libya's pending membership of the WTO and to facilitate means of trade between Libya and other countries, and to avoid any trade barrier in future, it is recommended that Libya work to realize the following:

- Food safety is important issues, which call for the modernisation of food control systems especially in view of increasing the international food trade.
- Capacity-building in training and education of all food workers to improve food safety and consumer protection services.
- More focus on maintaining appropriate skills and training for food inspectors in order to harmonize the inspection process.
- It is highly recommended to consider incorporating the administrations of all food control activities in Libya under one ministry or autonomous body to ensure co-ordination between the relevant sectors of the government to ensure effective protection for the consumer.

12. Conclusion

However, from the above it can be concluded that Food control system in Libya is fragmented and less sophisticated, and share, many of the ministries and departments responsible for food safety, with the lack of clarity in their roles and coordination between relevant institutions is weak (FOA, 2004), (FOA, 2006). Also the inspection systems focus on control of the final product and the reference is always the national standards (Law No. 4, 1993).

Acknowledgement

The author would like to thank Prof. David Eaton for his valuable comments.

13. References

- Beulens A., Broens, D., Folstar, P., and Hofstede, G. 2005. Food safety and transparency in food chains and networks, Relationships and challenges. *Food Control*, 16, pp.481-486.
- CDC, 2005. *Centers for Disease Control and Prevention*. Available at:< www.cdc.org>. [Accessed 3 November 2009].
- FAO/WHO, 2002. *Global Forum of Food Safety Regulators, Food borne disease*, Marrakech, Morocco: FAO/WHO, United Nations, 28 - 30 January 2002.
- FAO (Food and Agriculture Organization), 2004. *27th Report of FAO regional conference for the Near East*. Doha, Qatar 13-17 March 2004. FAO: United Nations.

FAO/WHO, 2005. *The impact of current food safety systems in the Near East/eastern Mediterranean region I on human health*, Amman, Jordan: FAO/WHO regional meeting on food safety for the Near East, 5–6 March 2005.

FAO (Food and Agriculture Organization), 2006. *28th Report of FAO regional conference for the Near East*. Sana'a, Republic of Yemen 12-16 March 2006. FAO: United Nations.

FAO, 2006. *Strengthening national food control systems: guidelines to assess capacity building needs*. Rome: Food and Agriculture Organization of the United Nations.

FAO, 2007. *Strengthening national food control systems: A quick guide to assess capacity building needs*, Rome: FAO, United Nations.

FAO, 2008. *Agriculture and Land and Water Use Commission for the Near EAST (ALAWUC). FIFTH SESSION*, Cairo, Arab Republic of Egypt: Reform of Agricultural Products Marketing Rules and Regulations in light of the New Socio-economic Changes.

FLIP, 2005. *Food Law Internet Project*. [online] Available at: <<http://www.reading.ac.uk/foodlaw/flip2000/libya.htm>> [Accessed 11 October 2007].

Industrial Organization, [1989]. *Law No. 22, Official Gazette*, pp.44- 19991.

LNCSM, 2007. *Technical manual work- Procedures for Conformity Assessment*, Tripoli, Libya: Centre of Standardization and Metrology,

Panisello, P.J., Quantick, P.C., and Knowles, M.J., 1999. Towards the implementation of HACCP: Results of a UK regional survey. *Food Control*, 10, pp.87–97.

Promulgates the Health Act [1973], *Law No. 106, Official Gazette*, pp.33- 1974.

The Standardization and Metrology, [1990]. *Law No. 5, Official Gazette*, pp.40- 199.

Wheeler, G., Sethi, D., Cowden, M., Wall, G., Rodriguez, C., Tompkins, S., Hudson, J., and Roderick, J., 1999. Study of infectious intestinal disease in England: rates in the community, presenting to general practice. *The Infectious Intestinal Disease Study Executive*, BMJ 1999; 318:1046.

WHO, 1999. *Food safety: EB 105/10*, Geneva, Switzerland: World Health Organization: United Nations.

An examination the impact the Nature and Particularities of Banking Services Industry on the Use of Performance Measurements: Libyan Evidence

Gumma Fakhri, Karim Menacere and Roger Pegum, *Liverpool John Moores University*

Abstract

The paper aims to examine the use of multiple-perspectives of performance measures in context of performance evaluation within the banking sector of Libya and to investigate the impact of some organizational characteristics of the use performance measures. Hence, this paper identifies the reality of measures perspectives taken from the performance measurement literature, and investigates the impact of five chosen organizational characteristics (e.g. the nature of bank services, the customers' demands, size of bank, and the listing on stock market) on the use of performance measures. Based on a scale survey in a sample of 55 respondents from different banks in Libya, the study develops hypotheses concerning the paper objectives, and uses descriptive and inferential statistical analysis to explore and examine the underlying impact of using multiple performance measures.

The findings of this study have found that most of the Libyan banks are putting their faith greatly in financial measures as primary approach to evaluate performance, although several banks are adopting the non financial measures, and they tend to implement customer related measures and learning and employee growth measures more frequently. The study has also discovered that there are significant differences in the use of financial and non financial measures according to banks' characteristics (nature and particularities) of banks, which lead to have varied perspectives of the use of performance measures in the Libyan banks.

Keywords

Performance Measures, Banking sector, Management Accounting, Libyan banks

1. Introduction

[Drury, \(2004\)](#) report that the management accounting literature underlined the importance of performance measurement process and how performance measurement systems play an important role in the financial success of the organisation, and as a source which provides appropriate information about internal activities. Therefore, firms are focused on the use of performance measures to help managers make basic decisions in order to achieve organisational objectives. In this regard, [Anthony and Govindarajan \(2001\)](#)

mention that performance measures are important for managers to track and to measure performance for their subunits, as well as for employees at lower levels to understand the financial impact of their operating decisions. In addition, the importance of use contemporary performance measures like quality service, customer satisfaction, etc comes from the highly competitive financial industry, particularly the banking sector, as well as in other services and even in manufacturing organisations (Hussain, 2002). Consequently, measuring the performance of financial and non-financial require special consideration in this particular kind of service organisation. Although a lot have been written about the need for accurate measurement of multi-dimensional performance measures, and there are a number of research concerning performance measurement, comparatively very little is known about performance measurement systems in services and the banking sector especially in developing countries like Libya. Therefore, the main purpose of this paper is to examine the impact of the Particularities /characteristics of banks on the use of financial and non-financial with particular reference to Libyan Banks.

2. A Brief Literature Review and Development of Hypothesis

The use of financial measures for evaluation purposes has some limitations in addition to the changes in business environment around organisations such as increased competition, have led to criticize reliance only on financial measures of performance measurement. As a result, the literature recommended that organisations should be considered the use of multiple measures in order to provide managers with adequate information about their overall organization performance (e.g. Ittner and Larcker, 1998; Neely, 1999; Kaplan and Norton, 2001; and Banker et al, 2000).

2.1. Financial Measures:

Financial performance measures were used in order to provide financial information to the managers and other users, also to evaluate efficiency and effectiveness. The more popular financial measures used for example are: return on investment; return on assets; return on capital employed; and earnings per share (Ittner and Larcker, 2003b). Although the use of financial performance measures is important in performance measurement, they have some limitations. For example, Kaplan and Norton, (1996) and Neely, (1999) conclude that there is agreement about the limitations of financial measures such as, they are too financially oriented, internal looking, historical and focusing on inputs not outputs, and are short term oriented. These limitations indicate that financial measures should be expanded to incorporate the valuation of the company's intangible and intellectual assets such as; high quality products, motivated and skilled employees, responsive and predictable processes, and satisfied and loyal customers in order to reflect the assets and capabilities that are critical for success in today's competitive environment (Kaplan

and Atkinson, 1998). These types of measures can be categorized as non-financial performance measures. Furthermore, Kaplan and Norton (1996) argue that measurement using only financial measures can damage an organisation's capacities and they recommend that a combination of financial and non-financial measures are better suited for evaluating performance.

2.2. Non -Financial Measures:

Several recent studies have provided empirical evidence on the positive impact of non-financial performance measures on the organisations' financial performance in the long-term (Anderson and Lanen, 1999; and Banker et al, 2000). Non-financial performance measures provide managers with timely information concentrated on the causes and drivers of success and can be used to design integrated evaluation systems (Fitzgerald et al, 1991; Kaplan and Norton, 1996; Banker et al, 2000). Fisher (1995) states that there are three main reasons for the emergence of non-financial performance measures: the limitations of traditional financial performance measures, competitive pressures, and the growth of other initiatives. In addition, Neely (1999) points out several reasons for this performance measures revolution such as increasing competition, changing organisational roles, changing external demands and the power of information technology. This in turn has led to the recognition that financial performance measures do not present a clear picture of organisational performance (Bourne and Neely, 2002). Most studies of non-financial performance measures are related to manufacturing with very few studies including services firms (Kald and Nilsson, 2000). Several studies (Fitzgerald et al, 1991; Kaplan and Norton, 2001; Hussain, et al 2002; Lorenzo, 2008) have emphasised the need to use multidimensional performance measures in the service sector such as the banking sector. Berry et al (1993) discussed performance evaluation in UK bank lending decisions, they argue that although manufacturing companies tend to emphasise the importance of non-financial performance measures, bankers are concerned with more financial performance measures. Ostinelli and Toscano (1994) examine the use of non financial measures namely customer satisfaction and improvement in quality management as an operational tool of control in three Italian banks. They found that the management control system was able to integrate both financial and non-financial measures to evaluate performance. Hussain et al (2002) carried out research on the role of management accounting practices in non-financial performance measures in financial institutions (including banks) in three countries Finland, Sweden and Japan. Their study found that contextual factors such as economic, normative, coercive factors have affected the role and the use of non-financial performance measures in the financial sector in three different countries. Al-Enizi et al (2006) examined the use of non-financial performance measures in the Gulf Cooperation Council Countries in four service companies (one of them was a bank). They suggested that non-financial performance measures have a

positive impact on long-term profitability. [Hussain and Hoque \(2002\)](#) examined what factors affected the design and use of non-financial performance measurement systems in Japanese banks. They found that several institutional features were influential in the banks' implementation of a particular performance measurement system including the central bank's regulatory control, bank size, and competition. [Hussain and Hoque \(2002\)](#) assessed the role of management accounting in non-financial performance among Japanese financial institutions-banks. They reported that management accounting has played a key role in measuring performance in different banks in Japan, but its role in non-financial performance measures has been less significant than its role in financial performance measures. The findings concluded that non financial performance measures are needed and the contextual factors affected the use of non-financial performance measurement in the sample studied.

The above discussion suggests that there are relatively few empirical studies which directly examine the use of financial and non financial measures for performance measurement purposes in the banking industry in developing countries but not in Libya. In addition, the conclusions from related previous studies provide two main arguments regarding the use of financial and non financial measures. The first argument points out that the use of financial measures is more common and standardized than non financial measures across the organization's sub-units as financial outcomes are the primary performance objectives. The second argument concludes that non financial measures have greater use beside financial measures in performance measurement systems, because non financial measures are better measures to driving future financial performance, and they reflect the value of long term aspects. Over the last decade, the balanced use of financial and non financial measures for performance measurement have been strongly recommended by scholars and professionals (e.g. [Kaplan and Norton 1996](#)).

It could be argued therefore that if financial measures are still fundamental for performance measurement in the Libyan banking sector context, therefore this paper sets the first hypothesis:

H.1 The Libyan banks tend to use financial measures rather than nonfinancial measures more frequently.

Consequently, in order to be aware of the performance measurement systems, it is essential to understand that performance measures are used at each organisational level. This paper focuses namely on financial and non financial performance measures.

3. Banking Particularities That Influencing Performance Measures

Since the 1980, there are many studies that focus on different aspects of management accounting practices especially in performance measurement such as their relationship with contextual factors (e.g. organisational size, customers' demand, nature of organization, and the joining to stock market). The different aspects of the literature will now be investigated in more detail.

3.1. The Impact of Size of Organisation

In response to such economic pressures, management accounting practices become adaptive to their environment with various degrees of responsiveness, but the characteristics of the company (e.g. size and type) are a key determinant to the degree of possible change and adaptation to the economic pressures (Granlund and Lukka, 1998; and Hussain and Gunasekaran, 2002). As for as the impact of size of organisation of performance measurement systems, several previous studies (Chenhall, 2003; Ezzamel, 1990) suggest that top management in large firms will implement a multiplicity of performance measures relative to small firms to motivate managers of different responsibility centers. For example, Chenhall (2003) indicates that size indeed affects the design of performance measurement systems: larger organizations use more sophisticated performance evaluation systems and tend to introduce non-financial measures. In addition, organisational size might influence the shape of control systems used which tends to be more sophisticated within bigger firms than smaller (Libby and Waterhouse, 1996; Speckbacher et al, 2003). In considering the impact of size of bank on the use of financial and non financial in the banking sector, this study argues that the size of service of a bank might impact accordingly on the use of financial and non financial measures in the Libyan banking sector. Previous research has indicated that size indeed affects the design of performance measurement systems: larger organizations use more sophisticated performance evaluation systems (Chenhall 2003) and tend to introduce non-financial measures (Hoque & James 2000). This results in the following hypothesis:

H.2 Size is positively associated with the use of financial and non financial performance measures.

3.2. The Impact Of Customers' Demands

The change in customers' attitudes and behaviour was one of the most important issues mentioned by the literature as a motive for using non financial measures, for example, Vaivio, (1999) indicates that customers' demands could be a basic theme to any organisation particularly in the service industries, devoting attention to customers leads to the introduction of some non-financial measures (customer satisfaction measures) which reflects the customer-organisation relationship. Moreover, there is an

increase in the number of organisations using customer satisfaction measures, due to managers' belief that these measurements affect financial performance outcome (Ittner and Larcker, 2003). However, Anderson et al. (1999) found positive associations between customer satisfaction and return on investment in Swedish manufacturing organisations, but weaker or negative connections in service organisations. Given the importance of customer bases, performance measurement systems should track the change of customer's performance regularly.

H.3 The customers' demands tend to affect the use of financial/non financial measures more frequently.

3.3. Nature of Banking Industry

It could be argued that the nature of the banking industry is service oriented and depends on human resources and this nature forced bank's management to be very aware about achieving a high level of quality, on-time delivery, customer satisfaction and loyalty and employee satisfaction and loyalty in change of business environment. Hussain and Gunasekaran, (2002) conclude that the nature of the banking industry is considered to be one of the motives for using range of performance measures as mentioned by their study's conclusion.

Cobb et al (1995) conclude that banking the activities, like bad loans in multinational banks, has impact on practice of non financial performance measures. In addition, Mills and Morris (1986) argue that customer of services organizations is essential to the production activities, so, some non financial measures (like quality) could be determined simply in manufacturing organisations, however in service organizations (like bank), it is difficult to assess the quality of its services because of their intangibility and transitory nature. In this case Simth's (1998) point out that measurement of the quality of service organisations is notoriously difficult.

Seemingly then, nature of services affect a performance measurement systems. In considering the impact of the nature of financial industry impact on non financial performance measures is investigated. This substantive hypothesis arose from above discussion and there was no contradictory evidence. Therefore, the fifth formal hypothesis is:

H.4 "The nature of the banking industry as a service oriented industry is one of the major motives that affect the use of financial/non financial measures more frequently.

3.4. The Impact of the Stock Market.

Larson and Kenny, (1995) argue that development of accounting information systems are fundamental for the improvement of the stock market, because users of accounting information (e.g. investors) require reliable and fitting information. In addition, Adhikari and Tondkar, (1992) conclude that there is a significant relationship between the development of the stock market and accounting information systems particularly in developing countries. The growing number of listed companies on the stock market creates a need for new information and services such as specific information such these about performance information. Furthermore, Douplik and Salter (1995) suggest that, as the level of activities increase in the stock market, users of information (i.e. investors and managers) want more financial and non-financial information about the companies' activities to assist in making decisions. Relating to the above, this study expects that the development or establishment of stock market may increase the need for using financial and non financial measures for performance measurement purposes. Therefore, the rationale for joint the stock market is that banks should improve the adoption and the use of non financial performance measures more than non other banks that do not joint yet. A null hypothesis statement is used as the basis for this rationale:

H.5 *There is no difference between stock market Listed and Unlisted in their use of performance measures.*

4. Libyan Banking Sector

Prior to the discovery of oil, Libya was one of the poorest countries in the world (Wright, 1981; Vandewalle, 1998). There was a deficit in the budget, in the balance of payments and most of the projects operated at a deficit (Higgins, 1959). Farley (1971), the UN's economist, pointed out that the Libyan economy before the discovery of the oil was underdeveloped and there was no indication of any economic growth.

The economy became primarily dependent on the revenues from the oil sector from 1961 (Wright, 1981; Vandewalle, 1998). These oil revenues and a small population give Libya one of the highest GDP per person in Africa. During the period 1951 (year of independence) to 1969 (Libyan revolution), the Libyan economic system was mainly capitalist.

After 1970 several steps were taken by the revolutionary government to reform the economic situation and it changed from a capitalist to a socialist economy. State intervention in the economy increased and the government started expanding the public sector and reducing the private sector. From the late 1970s to 1991 the Libyan economy was centrally planned and the State had managerial control of all the

manufacturing activities, foreign and domestic retail trade and banking as well as insurance services. However, private companies started to operate in Libya from the 1990s. Moreover, the Libyan national economy faced technical sanctions (imposed from the US/UN) which hindered the industrial enterprises from importing technology. As a result of these crises, the State introduced a series of economic and political liberalisation measures permitting a significant role for the private sector.

In 1992, to enhance economic development, the State issued Act number 9 to enhance the private sector activities in the national economy and to open the door for the privatisation of a number of public-sector companies. Since the early 2000s, the State has continued its economic reforms as it attempts to rejoin the international community. It has applied for membership of the World Trade Organisation (WTO), many State-run industries are being privatised, the US and UN sanctions were lifted and many international oil companies have returned to the country.

The banking sector is one of the most important in Libya and at the same time one of the most sensitive, structural constituents of the economy of any country. Historical sources show that the first banks in Libya were established at the end of the Ottoman period at the beginning of the 19th century. Since that time until the middle of the 20th century the commercial banks were branches of foreign banks such as Barclays Bank ([Al-Arbah, 1985](#)).

The Libyan banking sector now consists of the Central Bank of Libya, specialised banks (Libyan Arab Foreign Bank, Agricultural Bank, Saving and Investment Bank and Development Bank) and commercial banks. The commercial banks are organisations that have an economic and social role. The Libyan commercial banks consist of public commercial banks [State commercial banks (SCBs)] and private commercial banks ([Central Bank of Libya, 2001](#)). They had a significant role in the growth of the Libyan economy.

The period (1972-1992) was dominated by the five public commercial banks. On 13 November 1969 a decree was issued to Libyanise foreign banks to become Libyan joint stock companies with Libyan nationals owning more than 51% and the majority of their board of directors being Libyans including the chairman. In December 1970 Law No (153) nationalised foreign shares in the commercial banks, specified the contribution of Libyans in the banks, reorganised banks and increased the contribution of the Central Bank of Libya to 51% in banks where it was less than that. In order to keep up with the latest developments in both the national and international environment, legislation was enacted in the 1990s to encourage the private sector to participate in owning and managing commercial banks ([Masoud and Al-Shrif, 2002](#)).

From 1993 the banking sector witnessed important developments. Law No (1) 1993 [adjusted by Law No (1) 2005] allowed private banks to be established as well as permitting foreign banks to open branches, agencies or representative offices. The private banks established following this Law are Bank of Commerce and Development, Aman Bank for Commerce and Investment, Al-Ijmaa Al-Arab Bank, Al-Wafa Bank, Representative office of Jordanian Housing Bank and 48 small private banks (Luxford, 2005 and Central Bank of Libya, 2004) and they compete with the State banks and they have become very effective competitors. To observe international standards, the CBL has issued regulations for the commercial banks, such as the decisions of the Basle Committee concerning the suitability of capital to be in line with international developments and innovations and in order to reach a banking standard to compete in the international banking world.

5. Research method and survey instrument

The research has been conducted through a questionnaire preceded by an introductory letter clarifying the purposes and objectives of the entire project. The sample consists of ninety five managers from different banks in Libyan banking sector. Among this group of banks, the researcher contacted managers (include chief executive officer, senior and branch manager) directly in order to select a list of banks prepared to cooperate with the research. The survey was carried out by sending a questionnaire during the second half of 2009. After three follow ups by phone calls made to non-respondents to increase survey response rate, 83 questionnaires (55 usable) were sent back. The final response rate of about 57% represents an acceptable target when the questionnaire involves top and middle management levels. The questionnaire was developed and refined as follows: nearly all items in the performance measures and characteristics factors were adapted from previously published works. A preliminary draft of the questionnaire was discussed with my supervision team and some research students at LJMU to assess the content validity prior to pilot testing; and a pilot test was conducted with a group of five branches, whose inputs were used to improve the clarity, comprehensiveness and relevance of the survey instrument.

Specifically the questionnaire was structured in two parts. In the first part organizations were asked to indicate on a five point Likert scale – from 1 (not at all important/used), through 3 (moderately), up to 5 (extensively) – the extent to which they used a set of performance measures coming from academic/practitioner management accounting literature (Kaplan & Norton 1996, 2000; Gosselin 2005). The second part listed some characteristics factors such as the nature of banking services, size of banks, and strategic type of organizations.

5.1. Sample features

Data was analysed using the SPSS package v15.0. The reliability of the questionnaire was also verified. Internal consistency was established using Cronbach's Alpha it was equal (.815). The first empirical evidence of the survey is shown displayed through the use of descriptive statistics. Table (1) gives an account about some general information date of establishing, type of business, ownership, the total of assets, and the state of banks in Libyan stock market.

Table 1. Description of banks covered by the classification of survey

Classification Of banks by year of establishing business typology:			
Number (%)	Before 1980	Between 1991-2006	
	42 (76.5)	8 (23.5)	
Classification of banks by ownership typology :			
Number (%)	State-owned (public bank)***	Private	
		PAPP*	PSE**
	28 (51.5)	14 (25.0)	12 (23.5)
Classification of banks by total of assets typology:			
Number (%)	Less than 100	Above 100	
	9 (16.5)	46 (83.5)	
Classification of banks by Listing on Libyan Stock Market:			
Number (%)	Listed	Unlisted	
		23(41.2)	18(39.8)
State-owned public bank*** = (the state owns more than 50% of their shares), PAPP*= private after process of privatisation (before that they were public), PSE**= private since establishing			

Table 2. The extent of use of performance measurements

	Mea n	Std. D	Comparisons of survey results by Typologies:			
			Listing on SM		Size	
			Ls	Unls	S	L
Financial	3.70	0.77	3.60	3.814	3.68	3.765
Customer	2.98	0.83	2.85	3.116	3.02	2.882
Employee	2.32	0.74	2.25	2.388	2.41	2.059
Quality	3.20	0.90	3.17	3.234	3.19	3.235
Community	2.25	0.65	2.28	2.217	2.25	2.235
UNL un listed banks, L Listed banks, S small banks, L large banks, SM stock market						

Table 2 describes the distribution of respondents by the evaluation of the importance to bank success and the extent of current used of performance measures. In addition, adjust these measures as the size of bank and listing on stock market.

Table 3 explains distribution of respondents' opinions about the importance of elements of customers demand and ranks these elements' as the size of bank and listing on stock market.

Table 3 The customers' demands

	The level of importance			Mean	Std. D	Comparisons of survey results by Typologies:			
	1 / 2	3	4/5			Listing on SM		Size	
						Ls	Unls	S	L
Customer demands in banking industry is a critical factor that affects the use of performance measures in different banks	70.6	26.5	2.9	2.118	0.763	1.657	2.608	2.314	1.529
The bank checks its customer satisfaction regularly, although it requests high cost to obtain.	76.4	23.5	0	1.897	0.756	1.371	2.454	2.098	1.294
Bank's management believe that customer attained is key factor that affects the use of performance measures.	47.1	35.3	17.6	2.588	1.011	2.000	3.221	2.824	1.882
There is an increasing change in the customers' demands and attitude regarding banking service.	1.5	51.5	47.1	3.603	0.756	3.657	3.550	3.706	3.294

Table 4 give details about the respondents' views concerning the importance of nature of banking services which measured by four elements, these elements adjust as the size of bank and listing on stock market.

Table 4 The nature of banking services

	Level of importance of nature of banking services			Mean	Std. D	Comparisons of survey results by Typologies:			
	1	2/3	4/5			Listing on SM		Size	
						Ls	Unls	S	L
The banking industry is influenced by the changes in the level of progress in IT services.	17.6	78	4.4	2.236	0.794	2.200	2.272	2.353	1.882
It is extremely difficult to predict	29.4	69.1	1.5	1.98	0.78	1.94	2.03	1.98	2.00

another bank competitive move.				5	2	3	3	0	0
It is intricate to predict and keep up with changes in the governmental (The Central Bank of Libya) regulations.	47.1	53	0.0	1.58 8	0.60 4	1.45 7	1.72 1	1.66 7	1.35 3
Banking attributes and methods of service are constantly adapting to change and therefore unpredictable.	22.1	69.1	8.8	2.20 6	0.89 0	1.77 1	2.66 2	2.39 2	1.64 7

6. Findings of hypotheses testing

6.1. The use of financial and non financial measures

To test **H1**, the financial and non financial performance measures are ranked according to the mean of the extent to which respondents from Libyan banks are ranking them as important to success of long term and are using them in aforementioned practices. Table (2) accounts for the overall diverse measurements, the columns highlight this indicator which calculates by average standardised rating of importance and using for each category (financial and non financial measures). This indicator shows that if the level of overall diverse measurements is up to 3 that means banks use diverse sets of performance measures at a high level, however if the rate is less than if means if is not a high level of use for diverse sets of performance measures. From the table, it could be noted clearly that Libyan banks are still relying on financial performance measures.

The highest rate of overall diverse measurement column is financial measures which ranked by mean (3.706) and other the non financial measures are ranked less than the level of absenteeism (ranked +3). Therefore H1 is confirmed.

6.2. The impact of banking characteristics on performance measures

A factor analysis is undertaken in order to classify the measures into categories and to find out the underlying themes among the 8 items. Principal Component Analysis (table 5) reveals two interpretable factors with Eigen values greater than 1 that account for 64% of the variance. The two factors are labelled as follow: customers' demand (4 items); nature of banking services (4 items).

Table 5. *Factor analysis* (Rotated Factor Matrix for 8 items)

	Components	
	The nature of banking services	Customers demands
The banking industry is influenced by the changes in the level of progress in IT services.	0,5778	
It is extremely difficult to predict another bank competitive move.	0,6464	
It is intricate to predict and keep up with changes in the governmental (The Central Bank of Libya) regulations.	0,8329	
Banking attributes and methods of service are constantly adapting to change and therefore unpredictable.	0,8651	
Customer demands in banking industry is a critical factor that affects the use of performance measures in different banks		0,6326
The bank checks its customer satisfaction regularly, although it requests high cost to obtain.		0,7431
Bank's management believe that customer attained is key factor that affects the use of performance measures.		0,5878

To test the remaining four hypotheses a bivariate correlation is undertaken between the four factors, two of them coming from the Principal Component Analysis (PCA) (customers' demand, and the nature of banking services), while other two factors the joining to stock market and size of organisation are come from general information that categorize the respondents to listed and unlisted banks and small and large banks according to total of assets.

Table 6. Correlation Matrix (Tau (t) Kendall association measure

	Size of bank	The nature of services	Customers' demand	Listing on SM
Financial	0.079	0.065	.334(**)	0.138
Customer	.192(*)	0.122	.282(**)	.358(**)
Employee	.432(**)	0.001	.330(**)	.454(**)
Quality	.578(**)	0.032	.370(**)	.498(**)
Community	.407(**)	0.133	.210(*)	.403(**)

** Correlation is significant at the 0, 01 level (two - tailed).

* Correlation is significant at the 0, 05 level (two - tailed).

Table 6. shows all the results of this analysis. Kendall's tau (t) association coefficients help to determine whether there are some associations among four factors. These estimates are accompanied by p-values from statistical significance tests. The size of bank is positively correlated with non financial performance measures while it is so with financial performance measures but it is not significant. Thus, **H.2** (Size is positively associated with the use of financial and non financial performance measures) is accepted.

With regard to the nature of banking services is positively correlated with quality, financial, employee, and customer measures respectively, but less correlated with community measures. These results sustain the idea that the nature of banking services tend to use more non financial measures. Hence **H.3** is confirmed.

The customers' demands are positively correlated with financial and non financial performance measures (even if these values are not statistically significant). So **H.4** (The customers' demands are tend to use financial and non financial measures for performance measurement) is not confirmed.

Banks that listed in stock market are positively correlated with all performance measures while unlisted banks are negative correlated with non financial performance measures (even if this value is statistically significant). Overall these results appear coherent with the notion given that listed banks are positively correlated with use of non financial performance measures while, at the opposite, unlisted banks are negatively correlated. Therefore, **H5** (The jointing to stock market tends to affect the use of financial/non financial measures more frequently) is confirmed

7. The findings and literature

7.1. The use of financial and non financial measure

In terms of the use of financial and non financial measures this paper provides evidence about the Libyan banks is still reliance on financial measures with more attention for some non financial measures. These results are consistent with findings for number of previous studies (i.e. [Mohamed and Hussain 2005](#); [Ong and Teh 2009](#); [Ismail 2007](#); [Banker et al, 2004](#); [Chen et al, 2006](#); [Frigo and Krumwiede, 2000](#)).

The possible reasons for above result are that many Libyan banks still adopt customary accounting practices and insufficiency of qualified accountants and dominance of Central Bank as supervisors. There regulations exclude Libyan banks by requiring permission to create new internal change.

7.2. The impact of bank size of the use of financial and non financial measure

The size of bank as measured by total of assets is emerged as one of the motives encouraging the use of financial and non financial measures. The results indicate that there is a significant relationship between size of bank (total of assets) with the extent of using financial and non financial performance measures. as this result has already achieved by some of previous study such as [Verbeeten, 2004](#).

7.3. The impact of customers' demands on the use of financial and non financial measure

The results indicate that there is a weak relationship between customer's demand and the extent of using financial and non financial performance measures. This result is nearly similar for Al-Enizi et al's study in 2006.

7.4. The impact of nature of banking services on the use of financial and non financial measure

The nature of the banking industry emerged as a purpose leading to the use of financial and non financial measures. This finding is in agreement with previous findings or statements in the literature (see, for example, [Cobb et al, 1995](#) and [Hussain and Gunasekaran, 2002](#)).

7.5. The impact of jointing to stock market on the use of financial and non financial measure

The results confirm that there is a relationship but not a significant between joining the stock market and the extent of using financial and non financial performance measures. The study did not find support for this finding in the literature.

8. Limitations of the study

The aim of this research is to contribute to a better understanding of what performance measures are used by managers. Specifically this paper upgrades the existing theory, establishes relationships between contingencies factors and performance measures with contingency theory and shows some results that it would be interesting to develop further. However, this paper has some limitations to bear in mind. First of all, the sample comes from the Libyan banks without considering other perspectives (e.g., manufacturing, other services). Furthermore the paper does not consider how these contingency relationships may impact on the organisational performance and what combinations of performance measures can lead to improve financial results and organizational behaviour with more regular use.

Acknowledgement

Special thanks are owed to my two supervisor team who assistant in this paper, Karim Menacere and Roger Pegum for their guidance, helpful and insightful comments. In addition, I am indebted to a number of PhD students at Faculty of Business and Law in Liverpool John Moores University of the case firm due to their substantial co-operation during the research project. I am also grateful for the financial support provided by Libyan Bureau Cultural affair in London.

9. Reference

- Adhikari, A. And Tondkar, R. H. 1992. Environmental factors influencing accounting disclosure requirements of global stock exchanges. *Journal of International Financial Management and Accounting* Vol.4 (2).pp.75-105.
- Al-Arbah, S. A. 1985. The Banking System in Socialist People's Libyan Arab Jamahiriya", *The Institute of Banking Business and Management Publishing*, Al-Dar Arabia for Cyclopaedia, Beirut.
- Al-Enzi, A. M. N., Ianns, John. 2006. Non-Financial performance measurement in the banking sector: four grounded theory case studies. *International Journal of Accounting, Auditing and Performance Evaluation* Vol.3 (3).pp 362-385.
- Anderson, S.W., And Lanen, W. 1999. Economic transition, strategy and the evolution of management accounting practices: the case of India. *Accounting, Organizations and Society* Vol.24 (5-6).pp.379-412.
- Anthony, R. N., and Govindarajan, V. 2001. *Management Control Systems*. 10th ed. McGraw-Hill, New York.
- Banker, R D., Potter, G. And Srinivasan, D. 2000. An empirical investigation of an incentive plan that includes non-financial performance measures. *The Accounting Review* Vol.75 (1):pp.65-92.
- Berry, R. H., Crum, R. E. And Waring, A. 1993. *Corporate Performance Evaluation in Banking Lending Decisions* CIMA, London.
- Bourne, M And Neely, A. 2002. The success and failure of performance measurement initiatives: Perceptions of participating managers. *International Journal of Operations & Production Management* Vol.22 (11):pp. 1288-1310.
- Central Bank Of Libya. 2004, Annual Report No. 47th (2003), Musrath Al-Ezdihar Printing, Tripoli.
- Chen, H., Duh R, And Lin, J. C. 2006. The determinants of implementation stages of balanced scorecard. *Int. J. Management and Decision Making* Vol.7 (4).pp.356-376.

- Chenhall, R, H. 2003. Management control systems design within its organizational context: findings from contingency-based research and directions for the future. *Accounting, Organizations and Society* Vol.28:pp.127-168.
- Cobb, I. Helliari, C And Innes, J. 1995. Management accounting change in a bank. *Management Accounting Research* Vol.6:pp.155-175.
- Doupnik, T. S., And Salter, S. B. 1995. External environment, culture, and accounting practice: A preliminary test of a general model of international accounting development. *International journal of accounting* Vol.17 (3):pp.33-52.
- Drury, C. 2004. Management and cost accounting. 6th ed. Thomson: London.
- Ezzamel, L. 1990. The impact of environmental uncertainty, managerial autonomy and size on budget characteristics. *Management Accounting Research* Vol.1 (2):pp.181-197.
- Farley, R. .1971. Planning for Development in Libya, the Exceptional Economy in the Developing World, Praeger Publishers, New York.
- Fisher, J. 1995. Use of non-financial performance measures. In S.M. Young, Ed, Readings in Management Accounting, Prentice Hall, Englewood Cliffs, NJ. Pp.329-335.
- Fitzgerald, L. et al .1991. Performance measurement in service business. London: Chartered Institute of Management Accountants (DIMA).
- Frigo, M and Krumwiede, K. 2000. The balanced scorecard: a winning performance measurement system. *Management Accounting (USA)* Vol.81 (7):pp.50-54.
- Gosselin M. 2005. An empirical study of performance measurement in manufacturing firms, *International Journal of Productivity and Performance Management*, Vol. 54, No. 5/6, pp. 419-437.
- Granlund, M and Lukka, K. S. 1998. It's a Small World of Management Accounting Practices. Authors. *Journal of Management Accounting Research* Vol.10:pp.153-179.
- Guenther, T. And Gruening, M. 2002. Measuring performance: A cross-sectional empirical survey. In the 25th Annual Congress of the European Accounting Association Copenhagen Denmark.
- Higgins, B. 1959. Economic Development, W. W. Norton & Co., New York.
- HOQUE, Z and JAMES, W. 2000. Linking balanced scorecard measures to Size and Market Factors: Impact on Organizational Performance. *Journal of Management Accounting Research* Vol.12: pp 1-17.
- HUSSAIN, M. M. 2004. Organisational strategic orientation and its impact on non financial performance measurement in the financial services industry. *Management Research News* Vol.27 (11/12).pp.115-133.

- Hussain, M. M. 2005. Management accounting performance measurement systems in Swedish banks. *European Business Review* Vol.17, pp 566 – 589.
- Hussain, M And Gunasekaran, A. 2002. An institutional perspective of non-financial management accounting measures: a review of the financial services industry. *Managerial Auditing Journal* Vol.17:pp.518-536.
- HUSSAIN, M., M M. Islam., , A. Gunasekaran, and K, Maskooki. 2002. Accounting standards and practices of financial institutions in GCC countries. *Managerial Auditing Journal* Vol.17 (7):pp.350-362.
- Hussain, M and Hoque, Z. 2002. Understanding non-financial performance measurement practices in Japanese banks: A new institutional sociology perspective. *Accounting, Auditing & Accountability Journal* Vol.15 (2).pp 162-183.
- Ismail T. H. 2007. Performance evaluation measures in the private sector: Egyptian practices. *Managerial Auditing Journal* Vol.22 (5), pp.503-513.
- Ittner, C, D., and Larcker, D, F. 1998. Innovations in Performance Measurement: Trends and Research Implications. *Journal of Management Accounting Research* Vol.10:pp.205-238.
- Ittner, C, D., and Larcker, D, F. 2003a. Coming up short on non financial performance measurement. *Harvard Business Review* Vol.81 (11):pp.88-95.
- Ittner, C, D., Larcker, D, F. And Taylor, R. 2003b. Performance implications of strategic performance measurement in financial services firms. *Accounting, Organizations and Society* Vol.28 (7-8). pp 715-741.
- Kaplan, R and Atkinson, A. 1998. *Advanced Management Accounting*. 3rd ed. London: Prentice Hall International.
- Kaplan, R and Norton, D. 1992. The balanced scorecard measures that drive performance. *Harvard Business Review* Vol.70 (1):pp.71-79.
- Kaplan, R and Norton, D. 1996. Using the balanced scorecard as a strategic management system. *Harvard Business Review* Vol.74 (1):pp.75-85.
- Kaplan, R And Norton, D. 2001. Transforming the balanced scorecard from performance measurement to strategic management. *Accounting Horizons* Vol.15 (1):pp. 87-104.
- Larson, R, K. and Kenny, S. Y. 1995. An Empirical analysis of international accounting standards, equity markets, and economic growth in developing countries. *Journal of International Financial Management and Accounting* Vol.6 (2):pp.130-157.

- Libby, T and Waterhouse, J. H. 1996. Predicting change in management accounting systems. *Journal of Management Accounting Research* Vol.1:pp.137-150.
- Lorenzo, L. 2008. Performance measures from a contingency perspective: field evidence. In 31st Annual Congress of the European Accounting Association. Rotterdam, April 23-25 European Accounting Association.
- Luxford, K. 2005. Libya Beats a Path to Foreign Bankers. *Euromoney*, Vol. 36, Issue 437.
- Masoud, A. M. and Al-Shrif, B. 2002. The Libyan Commercial Banks – the Development and Activation. *Journal of Arab Banks Union*, No. 259, pp. 81-88.
- Mills, P.K. and Morris, J.H. 1986. Clients as 'partial' employees of service organisations: role of development in client participation. *Academy of Management Review*, Vol. 11, pp. 726-35.
- Mohamed, E. K. A., and Hussain, M. M. 2005. Management accounting and performance measurement practices in services sector in Oman. *Int. J. Management and Decision Making*, Vol.6 (2).pp.101-111.
- Neely, A. 1999. The performance measurement revolution: why now and what next. *international Journal of Operations & Production Management* Vol.19 (2):pp.205-228.
- Ong, T. S and Teh, B. H., 2009. The use of financial and non financial performance measures in the Malaysian manufacturing companies. *The Icfai University Journal of Accounting Research* Vol.VIII (1).pp.23-30.
- Ostinelli, C and Toscano, G. 1994. Putting quality to work in banking through management accounting systems: three Italian banks. In the 17th Annual Congress of the European Accounting Association. Venice.
- Smith, M. 1998. Measuring organisational effectiveness. *Management Accounting*, October, pp. 34-6.
- Speckbacher, G., Bischof, J. and Pfeiffer, T. 2003. A descriptive analysis on the implementation of balanced scorecards in German-speaking countries. *Management Accounting Research* Vol.14 (4):pp.361-387.
- Vaivio, J. 1999. Exploring a non-financial management accounting change. *Management Accounting Research* Vol.10 (4):pp.409-437.
- Vandewalle, D. 1998. *Libya since Independence: Oil and State-Building*, Cornell University Press.
- Verbeeten, F. 2004. Performance measurement and long-term managerial contract: empirical investigation. The 27th Annual Congress of the European Accounting Association (Prague- Czech Republic).
- Wright, J. 1981. *Libya: A Modern History*, Croom Helm, London.

Identification of Wheel-Rail Contact Condition Using Multi-Kalman Filtering Approach

I Hussain and T. X. Mei, *School of Computing, Science and Engineering, Salford University*

Abstract:

Condition changes at the rail surface due to the fallen tree leaves and/or other contaminations can cause the low adhesion levels which present a serious challenge for the traction/braking control systems to avoid the problem of wheel slip/slide. This paper presents a multiple model based method for the identification of the adhesion limit to overcome the problem of the wheel slip/slide in poor contact conditions. The proposed scheme is an indirect method that exploits the dynamic properties of the conventional solid axle wheelset in response to changes in contact condition at the wheel-rail interface avoiding difficult and expensive measurement requirements. A nonlinear model of lateral and yaw dynamics of a conventional solid axle wheelset is used for the study. The non-linearity and changes in the interaction with the rail are modelled by using a set of non-linear creep/slip curves. The scheme consists of a bank of Kalman filters based on the linearized wheelset models. Each Kalman filter in the filter bank is optimally tuned to operate in a specific contact condition. Normalized root mean square values from the residual of each filter calculated using time moving windows are assessed to identify the operating condition of the wheelset. This paper mainly covers: (1) the modelling of wheelset dynamics and non-linear contact laws and that of condition changes at the wheel-rail interface; (2) the design detail of the Kalman filters; (3) Identification of wheel-rail contact conditions and; (4) simulation results to demonstrate potential effectiveness of the proposed scheme.

Keywords:

Wheel rail contact, Estimation, Kalman filters, Fuzzy logic

1. Introduction

The traction and braking performance of the railway vehicle is governed by the contact forces generated at the wheel rail interface. These contact forces are a non-linear function of the creepages and vary substantially when the conditions of the rail surfaces change due to the contaminations. The overall adhesion can therefore become very low which results in wheel slip/slide. The wheel slip/slide is a highly undesirable phenomenon that causes the mechanical parts to wear down quickly affects the stability and leads to the inconsistent traction performance causing problems in train scheduling.

In order to avoid the wheel slip/slide various different techniques have been used in past. (Watanabe and Yamanaka, 1997, Watanabe et al., 1997) presented a conventional technique of controlling the wheel slip based on the measurement of the relative speed between the wheel and the train which was supplemented with the control of the wheel acceleration. Also hybrid anti-slip methods which are also based on the relative speed measurement are proposed (Choi and Hong, 2002, Park et al., 2001). These controllers require an accurate measurement of the train and wheel rotational speeds that makes it difficult to obtain the optimal performance. Another method based on disturbance observers are proposed to detect the slip conditions (Kim et al., Choi and Hong, 2002). These controllers do not require direct speed measurement rather the adhesion coefficient is estimated by using the information of rotor speed and the torque current but the performances of the anti-slip schemes based on a disturbance observer are to a large extent affected by noises in the system which can be very substantial in the wheel-rail contact environment. (Mei et al., 2009) proposes an indirect technique that exploits the wheelset dynamics to develop wheel slip protection.

The real time information about the maximum adhesion available as a train travels through a track would help to tackle the problem of the wheel slip/slide. The provision of the tractive effort in either traction or braking could then be optimised to make the most out of the wheel-rail contact conditions.

This paper is an extension of an ongoing research that uses the multiple model based estimation approach for the identification of the contact conditions (T X Mei, 2010, I Hussain, 2009, I Hussain, 2010). In a previous study, the residual of estimated states were examined to determine

the operating condition. In this paper a fuzzy logic based identification method is developed to determine the contact condition.

2. Wheelset Modelling

A solid axle railway wheelset (figure-1) with both the wheels fixed with the axle is used for this study. Both the wheels have profiled tread with the conicity γ . This coned tread provides a natural feedback (due to the difference in the rolling radius) for the wheelset to adjust itself on the centre position when it is slightly displaced laterally. The motions of the wheelset are governed by the nonlinear creep forces generated at the wheel rail contact patch in the lateral and longitudinal directions. Creep is said to exist when the railway wheels deviate from pure rolling and can be described as the relative motion of wheels to the rails given in equations (1), (2) & (3). Delivery of tractive effort in traction and braking is achieved via longitudinal creep.

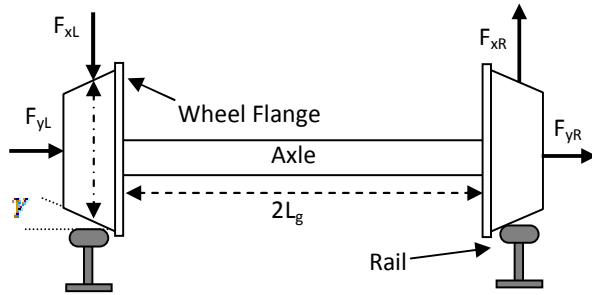

Fig.1. Railway Wheelset

$$\lambda_{xL} = \frac{r_o \omega_L - v}{v} + \left[\frac{L_g \dot{\psi}}{v} + \frac{\gamma(y - y_t)}{r_o} \right] \quad (1)$$

$$\lambda_{xR} = \frac{r_o \omega_R - v}{v} - \left[\frac{L_g \dot{\psi}}{v} + \frac{\gamma(y - y_t)}{r_o} \right] \quad (2)$$

$$\lambda_{yL} = \lambda_{yR} = \frac{\dot{y}}{v} - \psi \quad (3)$$

In above equations the subscript L, R are used for left and right wheels respectively, x and y are used to indicate the longitudinal and lateral directions, and $\lambda_{xL}, \lambda_{xR}, \lambda_{yL}$ and λ_{yR} are creepages in

the longitudinal and lateral directions for left and right wheels. ω_R and ω_L are angular speeds of right and left wheels respectively, Ψ is yaw angle, y is lateral motion, L_g is the half track gauge, v is forward speed of the vehicle, γ is conicity of wheel and r_o is the radius of wheel when it is at centre position and y_t is disturbance applied by track in lateral direction. The total creep at any point on the creep curve is given by following equations.

$$\lambda_L = \sqrt{\lambda_{xL}^2 + \lambda_{yL}^2} \quad (4)$$

$$\lambda_R = \sqrt{\lambda_{xR}^2 + \lambda_{yR}^2} \quad (5)$$

2.1 Simplified model

Only lateral and yaw dynamics are found to be sufficient to identify the track condition (I Hussain, 2010). The simplified equations of longitudinal creep for the left and the right wheel are given below.

$$\lambda_{xL} = \frac{L_g \dot{\Psi}}{v} + \frac{\gamma(y - y_t)}{r_o} \quad (6)$$

$$\lambda_{xR} = -\frac{L_g \dot{\Psi}}{v} - \frac{\gamma(y - y_t)}{r_o} \quad (7)$$

The yaw angle is the result of the difference in the longitudinal creep forces between the two wheels and the lateral dynamics are determined by the total creep force of the two wheels in the lateral direction. The equations for the lateral and the yaw motions of the railway wheelset are given in (8) and (9).

$$m_w \ddot{y} = -f_{yR} - f_{yL} + F_c \quad (8)$$

$$I_w \ddot{\Psi} = f_{xR} L_g - f_{xL} L_g - k_w \Psi \quad (9)$$

Where m_w is the wheelset mass, F_c is the centrifugal component of the force and can be ignored if the wheelset is not running on the curved track, I_w is the yaw moment of inertia and k_w is the yaw stiffness of a spring used to stabilise the wheelset. f_{yL} , f_{yR} , f_{xL} and f_{xR} are the creep forces of left and right wheels in lateral and longitudinal directions.

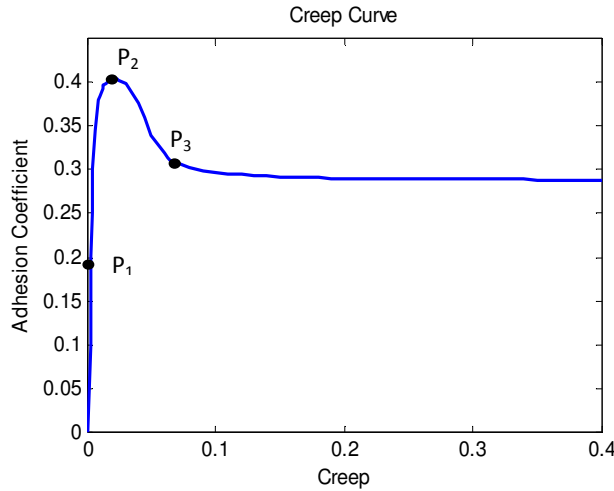

Fig.2. Adhesion Coefficient variation

The creep forces in equation (8) and (9) are widely recognised to present the non-linear characteristics as a function of creep as shown in Figure 2. In normal running conditions where the creep is small, the contact forces provide a damping effort to the dynamic modes of a wheelset and are very useful in stabilising those modes. As the creep increases, due to application of tractive effort, the contact forces can operate in the second (or non-linear) region where the rate of change of the creep forces and associated damping effect is much lower. However, when the creep is beyond the point of maximum adhesion (μ_m) available at the wheel-rail interface and enters the slip or unstable region, the contact forces will then become a destabilising element, which not only cause the well known problem of wheel slip (in traction) or slide (in braking) but also can cause other undesirable mechanical oscillations in the wheelset (T X Mei, 2010).

3. Kalman Filter Design

Kalman filter is a useful tool to estimate the parameters of a linear stochastic process with unknown disturbances, such as the railway wheelset with unknown track disturbance, with some knowledge of the process output and the model. As it works well when the system is linear the nonlinear creep forces are linearized at specific point on the creep curve (λ_o, μ_o) as shown in

equation (10) (I Hussain, 2009). The derivative terms represent the slope on the creep curve at the point of linearization which is simplified and represented by g_{11} and g_{12} .

$$f_{xR} = f_{xRo} + \left. \frac{\partial f_{xR}}{\partial \lambda_{xR}} \right|_{(\lambda_{xRo}, \lambda_{yRo})} \times \Delta \lambda_{xR} + \left. \frac{\partial f_{xR}}{\partial \lambda_{yR}} \right|_{(\lambda_{xRo}, \lambda_{yRo})} \times \Delta \lambda_{yR} \quad (10)$$

Or

$$f_{xR} = f_{xRo} + g_{11} \Delta \lambda_{xR} + g_{12} \Delta \lambda_{yR} \quad (11)$$

All the creep forces are linearized in the similar way and the linearized small signal model of the lateral and yaw dynamics of the railway wheelset is obtained.

$$\begin{bmatrix} \Delta \dot{y} \\ \Delta \dot{\psi} \\ \Delta \ddot{y} \\ \Delta \ddot{\psi} \end{bmatrix} = \begin{bmatrix} 0 & 0 & 1 & 0 \\ 0 & 0 & 0 & 1 \\ 0 & \frac{2g_{22}}{m_w} & -\frac{2g_{22}}{vm_w} & 0 \\ -\frac{2L_g g_{11}}{r_o I_w} & -\frac{k_w}{I_w} & 0 & -\frac{2L_g^2 g_{11}}{v I_w} \end{bmatrix} \begin{bmatrix} \Delta y \\ \Delta \psi \\ \Delta \dot{y} \\ \Delta \dot{\psi} \end{bmatrix} + \begin{bmatrix} 0 \\ 0 \\ 0 \\ \frac{2L_g g_{11}}{r_o I_w} \end{bmatrix} \Delta y_t \quad (12)$$

This model is valid only at specific point on the creep curve and best estimation results may be obtained when the wheelset is operated in the vicinity of the point where it is linearized. Equation (12) gives us idea how dynamics of wheelset are affected when operating point of the wheelset (i-e g_{11} and g_{22}) is changed.

3.1 Kalman filter formulation

The wheelset dynamics are excited by the unknown track disturbance. In order to obtain a good estimation results the unknown track disturbance is treated as part of the state vector as shown in the following equation.

$$\begin{aligned}
\frac{d}{dt} \begin{bmatrix} \Delta\psi \\ \Delta\dot{y} \\ \Delta\dot{\psi} \\ \Delta y_t \\ \Delta y - \Delta y_t \end{bmatrix} &= \begin{bmatrix} 0 & 0 & 1 & 0 & 0 \\ \frac{2g_{22}}{m_w} & -\frac{2g_{22}}{vm_w} & 0 & 0 & 0 \\ \frac{k_w}{I_w} & 0 & -\frac{2L_g^2 g_{11}}{vI_w} & 0 & -\frac{2L_g g_{11}}{r_o I_w} \\ 0 & 0 & 0 & -0.001 & 0 \\ 0 & 1 & 0 & 0 & 0 \end{bmatrix} \\
&\quad + \begin{bmatrix} \Delta\psi \\ \Delta\dot{y} \\ \Delta\dot{\psi} \\ \Delta y_t \\ \Delta y - \Delta y_t \end{bmatrix} + \begin{bmatrix} 0 \\ 0 \\ 0 \\ 1 \\ -1 \end{bmatrix} \dot{y}_t \quad (13)
\end{aligned}$$

Two sensors (A gyro sensor for the yaw rate measurement and an accelerometer for the lateral acceleration measurement) as indicated in (14) (v is a vector representing noise level of the sensors with the covariance R) appear to be sufficient for the Kalman filter to provide satisfying estimation results.

$$z(t) = \begin{bmatrix} 0 & 0 & 1 & 0 & 0 \\ \frac{2g_{22}}{m_w} & -\frac{2g_{22}}{vm_w} & 0 & 0 & 0 \end{bmatrix} \begin{bmatrix} \Delta\psi \\ \Delta\dot{y} \\ \Delta\dot{\psi} \\ \Delta y_t \\ \Delta y - \Delta y_t \end{bmatrix} + v \quad (14)$$

Following figure shows the multiple Kalman filter based estimators. Each Kalman filter design is based on the small signal model linearized at specific point on the creep curve. The Kalman filters are optimally tuned by selecting optimal value of covariance matrix R .

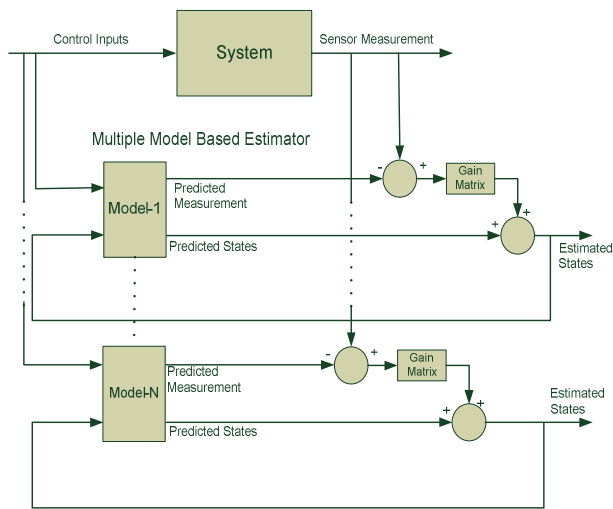

Fig.3. Multiple Model Based Estimation (I Hussain, 2009)

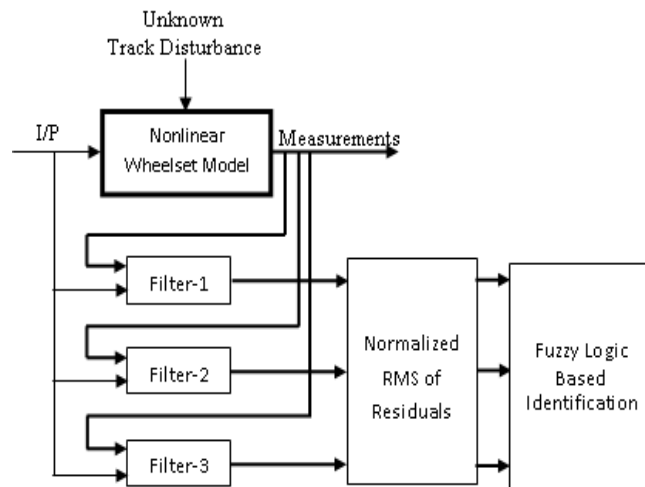

Fig.4. Contact Condition Identification Scheme

The complete proposed scheme is shown in the figure-4. Only three filters are used here to show the potential of the research. The three chosen operating points are shown in figure-2 as P_1 (Linear region of the creep Curve), P_2 (Maximum Point of the creep curve where rate of change of creep force is zero) and P_3 (Unstable Region). Filter-1, filter-2 and filter-3 are designed to operate at these points respectively. Number of Kalman filters can be increased easily to include all possible contact conditions. The normalized values of the residuals of estimated states are

then calculated with moving time window of one second. Normalized values of residuals of lateral acceleration are shown in figures (5), (6) and (7) when the wheelset was operated at P_1 , P_2 and P_3 respectively. Error-1, Error-2 and Error-3 are the errors produced by Filter-1, Filter-2 and Filter-3 respectively.

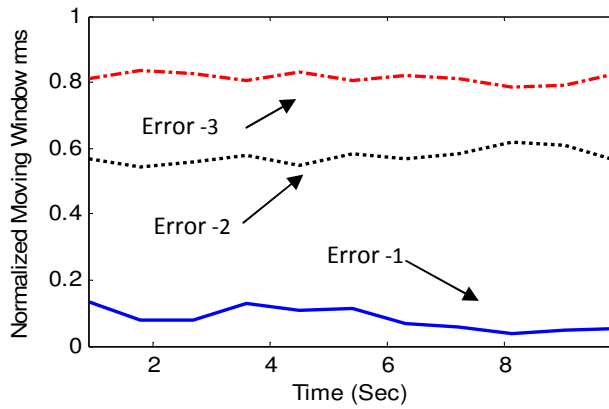

Fig.5. Normalized rms of residuals at P_1

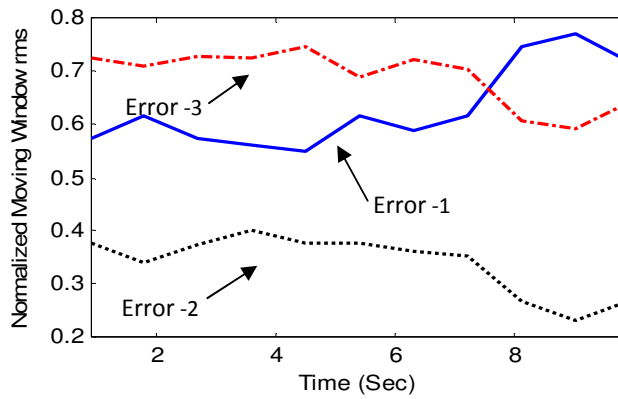

Fig.6. Normalized rms of residuals at P_2

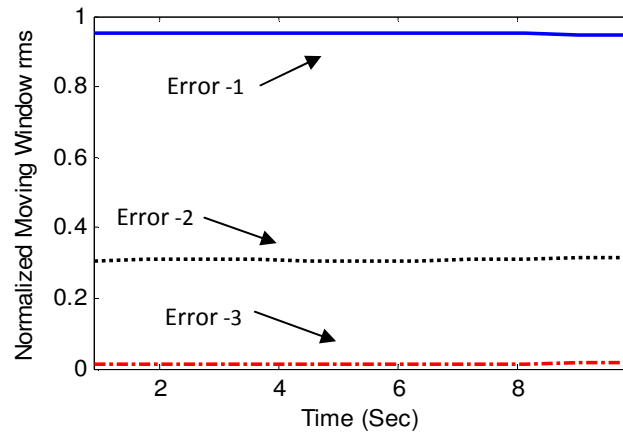

Fig.7. Normalized rms of residuals at P₃

The results show when the wheelset is operated around a point where the any specific filter is optimally tuned to operate the respective filter has minimum error around that point also the amount of error is increased or decreased depending upon how far the wheelset is operating from that point. This provides an excellent opportunity to develop a fuzzy logic based identification system based on these results as shown in the figure below.

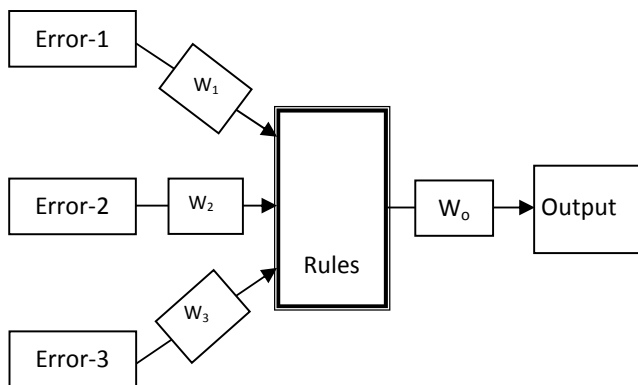

Fig.8. Fuzzy Logic Based Identification System

The normalized values of the residuals are fed to the fuzzy logic system with specific membership function which associates a weighting with each of the input that are processed. The weighting function determines the amount of participation of each input in the producing the output. The rules use the input membership values as weighting factors to determine their influence on the output. Output is produced in terms of the probability of the operating point near to P_1 , P_2 and P_3 . Figure (9) is an example out of the system when the wheelset was operated in the vicinity of P_1 . The fuzzy output indicates 90% probability of operating point is around P_1 . The simulation was carried out at various different operating points and the results showed excellent agreement with the theory.

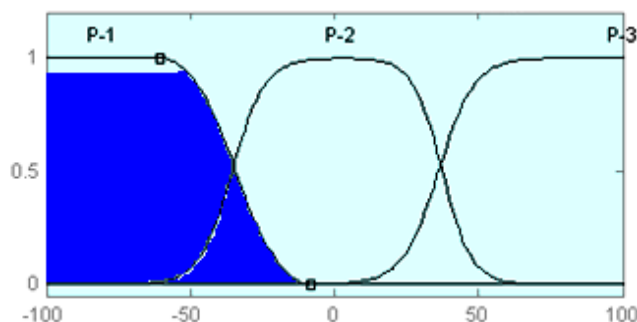

Fig.9. Output Membership Function

Conclusions and further work

The good delivery of the tractive effort in the traction and braking can be achieved through the real time knowledge of the contact condition. This research proposes a novel technique to identify the contact condition by investigating the changes in the dynamic properties of the wheelset as the train travel through the track. The proposed scheme indirectly identifies the contact condition with minimum measurement requirement. The results presented show the satisfactory performance. However the simulation is carried out using only one creep curve representing good/dry contact condition with small changes in the creep due to application of the tractive torque. Further research is been carried out to validate this model on different creep curves representing low adhesion conditions with large changes in the creep forces.

References

- CHOI, H. & HONG, S. (2002). Hybrid control for longitudinal speed and traction of vehicles. pp. 1675-1680
- I HUSSAIN, Mei. T. X. (2010). Multi Kalman Filtering Approach for Estimation of Wheel-Rail Contact Conditions *Proceedings of the United kingdom Automatic Control Conferecne 2010*. pp.459-464
- I HUSSAIN, M. T. X. A. A. H. J. (2009). Modeling and Estimation of Nonlinear Wheel-rail Contact Mechanics. *Proceedings of the twentieth Intenational conference on System Engineering*, pp. 219-223.
- KIM, W., KIM, Y., KANG, J. & SUL, S. (1999).Electro-mechanical re-adhesion control simulator for inverter-driven railway electric vehicle. pp.1026-1032
- MEI, T.X, YU, J. & WILSON, D. (2009). A mechatronic approach for effective wheel slip control in railway traction. *Proceedings of the Institution of Mechanical Engineers, Part F: Journal of Rail and Rapid Transit*, 223, pp. 295-304.
- PARK, D., KIM, M., HWANG, D., LEE, J. & KIM, Y. (2001). Hybrid re-adhesion control method for traction system of high-speedrailway. pp.739-742
- T X MEI, I. Hussain. (2010). Detection of wheel-rail contact conditions for improved traction control. *Proceedings of the 4th international conference on Railway Traction systems*.
- WATANABE, T. & YAMANAKA, A. (1997). Optimisation of readhesion control of Shinkansen trains with wheel–rail adhesion.
- WATANABE, T., YAMANAKA, A., HIROSE, T. & NAKAMURA, S. (1997). Optimization of readhesion control of Shinkansen trains with wheel-rail adhesion prediction. *In*, pp. 47-50.

A novel single step process for making CuInSe_2 absorbing layers for solar cell applications

Sreejith Karthikeyan, Arthur Hill and Richard Pilkington, *University of Salford*

Abstract

CuInSe_2 (CIS) thin films may be used as the absorbing layer in solar cells and are an important source of renewable energy. The complexity of this material makes it difficult to design a single step process to deposit p-type CIS with the 25% copper, 25% indium and 50% selenium (stoichiometric ratio 25:25:50) layer required for an efficient cell. These stoichiometric films have previously been deposited by a multi-step processes. This work describes the use of pulsed D.C. magnetron sputtering (PDMS) - a unique single step technique that can produce stoichiometric CuInSe_2 films. The p-type CIS films which were produced by this technique were found to have low resistivity, were pinhole free and adhered well to the glass substrate. The films, deposited from CIS powders with different composition ratios at room temperature, were all found to be nearly stoichiometric, almost irrespective of the starting composition of the powder material. The physical and structural properties of these films were analysed using XRD and SEM. Conductivity measurements were carried out using the four point probe and hot probe methods. Traditional vacuum deposition techniques either use separate targets for each of the three elements and control the rate of each deposition individually, which is complex, or the film must be treated using a selenisation process after deposition in order to compensate for selenium deficiency, which is potentially a toxic process. Our single step deposition process can cut down the cost and risks involved in the traditional vacuum based deposition techniques.

Keywords

Pulsed D.C magnetron sputtering, CuInSe_2 films, stoichiometric CuInSe_2 films, photovoltaic, thin film solar cells, single step CuInSe_2 films.

1. Introduction

The main sources of global energy are fossil fuels. These have limited availability and are also associated with environmental problems. One of the main challenges of this century is to find eco-friendly energy sources which can supply the global energy demand. Solar energy is one such source. Analysis shows that every hour; enough

sunlight energy reaches the Earth to meet the world's energy demand for a whole year.¹ Solar cells are devices that can convert sunlight into electricity with the aid of specialised photosensitive semiconductors called photovoltaic materials. In the early stages of solar cell research the cells were made from semiconductor grade single crystalline silicon and were the power source for space applications such as satellites. The systems were very reliable and cost was of little concern with regard to the huge space program budget. But today, these solar cells are integrated with equipments like calculators, garden lights, mobile chargers etc, and cost is a major factor. There are different types of solar cells available which can be classified it into several categories such as:

- Silicon based solar cells

- III-V Group single crystals (GaAs, InP based)

- Organic photovoltaics

- Thin films (CdTe, CuInSe₂)

Crystalline silicon based cells are the most common type of solar cells. The main problem is the indirect band gap. Semiconductors with an indirect band gap have a lower light absorption efficiency compared to those with a direct band gap. In simple words this means that, for 90% of light absorption efficiency, a thickness of 100 μ m of single crystalline silicon is required. In comparison, a direct band gap material such as GaAs requires a thickness of only 1 μ m (Goetzberger and Hebling, 2000;1-19).

GaAs and InP cells are fabricated using metallorganic chemical vapour deposition techniques on monocrystalline wafers and have the highest electrical conversion efficiencies (typically 28 to 29 percent but recently as high as 40 percent). However, these multi junction cells are expensive to manufacture and are therefore usually limited to applications where cost is not an issue or where only small active areas are needed, such as satellites or solar concentrators.

Organic photovoltaics are the latest versions of solar technology. They are based on molecular semiconductors and have attracted significant scientific and commercial interest due to their potential use for low cost, flexible solar cells. The primary device architecture is a multi-layer structure where charge photo-generation occurs at interfaces between electron donor and acceptor molecules (Palilis et al., 2008;747-52)

¹ <http://www.makeitsolar.com/solar-energy-information/04-sun-energy.htm>

(Tang, 1986;183-5). However, the efficiency of such cells is currently very low, of the order of 5%, and still under research.

Thin film based solar cells are the alternative approach. The processes of cell manufacture are intrinsically of lower cost than for crystalline cells because there is less material wastage. Three main types of thin film based solar cells are:

Hydrogenated amorphous silicon (a-Si:H)

Cadmium telluride (CdTe) based cells.

Copper indium diselenide CuInSe₂/Cu (In,Ga) based cell.

Hydrogenated amorphous Si is a promising candidate for thin films compared to crystalline Si because its short range order and many dangling bonds create trap sites throughout the band region. The disadvantage of these cells is that long term light exposure can decrease the photoconductivity - the Staebler–Wronski effect (Staebler and Wronski, 1980;3262-8). This questions the use of use of hydrogenated amorphous silicon based solar cells for long term use.

CdTe material based thin films are the next candidate among the three popular thin films based solar cell materials. CdTe materials have high-energy conversion efficiency but the high work function and toxicity of Cd makes CdTe a less attractive material.

CuInSe₂/Cu(In,Ga)Se₂ based solar cells have reached a maximum efficiency of 20.1%. A typical cell is a hetero junction of different material layers based on a Mo/CuInSe₂/CdS/i-ZnO/ZnO structure. The CuInSe₂ layer is known as the absorbing layer and is the heart of the solar cell. Because of its high potential, researchers have developed a variety of techniques to deposit CIS thin films such as flash evaporation (Durný et al., 1980;L11-L3) (Salviati and Seuret, 1983;L75-L8), co-evaporation (Amara et al., 2006;251-6), sputtering (Rockett et al., 1989;109-23) (Piekoszewski et al., 1980;363-72), molecular beam epitaxy (Niki et al., 1995;1201-5), spray pyrolysis (Subbaramaiah and Sundara Raja, 1992;247-51) (Pamplin and Feigelson, 1979;141-6), chemical vapour deposition (Jones et al., 1994;4-7) etc. Many of these require a potentially dangerous post selenisation process (Mudryi et al., 2003;193-6; Bekker et al., 2001;40-3; Song et al., 2003;145-53). The use of H₂Se during selenisation requires extensive health and safety measures and can introduce secondary phase formations

² http://www.zsw-bw.de/fileadmin/ZSW_files/Infoportal/Presseinformationen/docs/pi05-2010-ZSW-Worldrecord-TF-CIGS.pdf

such as In₂Se which degrade the properties of the CIS films (Deok Kim et al., 2000;357-68). These processes are therefore complex and reproducible control of the deposition parameters is a difficult task. The main objective of this work is to find a simplified process that will allow the deposition of stoichiometric CIS thin films using a single stage process capable of producing large area device quality material.

This work describes such a deposition process from a polycrystalline CIS powder target using Pulsed D.C Magnetron Sputtering (PDMS) in the mid frequency region (10 to 350 kHz). Pulsed D.C. sputtering alleviates the target charging problems associated with R.F sputtering and continuous D.C sputtering. This is achieved by the production of a stable sputtering plasma during the pulse on time and discharge of the charged regions on the target during the reverse voltage or pulse off time. PDMS has been used to deposit dielectric materials in a long-term arc free environment.(Kelly and Arnell, 1998;2858-69) which has proved difficult using other sputtering techniques The quality of deposited PDMS films can be adjusted using various parameters such as frequency, duty cycle, voltage, current etc. The optimum choice of these will result in coatings with the desired characteristics.

2. Experimental details

2.1 Crystal Growth

Polycrystalline copper indium diselenide (CIS) crystals were made by the direct fusion method from the component elements using a rocking furnace (Tomlinson, 1986;17-26). The rocking mechanism ensured the homogeneous mixing of the molten elements. A schematic of the rocking furnace is shown in Figure 1.

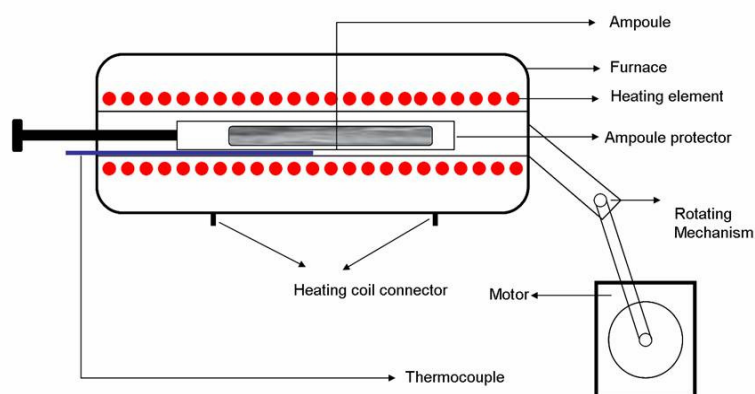

Figure 1 Schematic of Rocking Furnace

5N pure copper, indium and selenium were sealed inside a cleaned, dry quartz ampoule under vacuum. The sealed ampoules were heated and subsequently cooled inside a rocking furnace controlled by a Eurotherm programmable temperature controller. Figure 2 shows the base elements and the resulting polycrystalline CIS. Various atomic compositions of CIS were grown. Crystals were then powdered for use as sputtering targets.

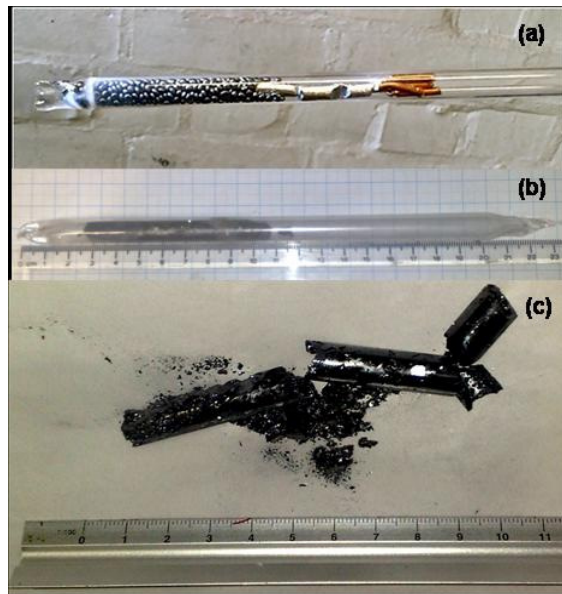

Figure 2 (a) Base elements before reaction (b) CIS crystals inside ampoule after reaction (c) CIS crystals after removal from ampoule.

2.2. Pulsed D.C Magnetron Sputtering System

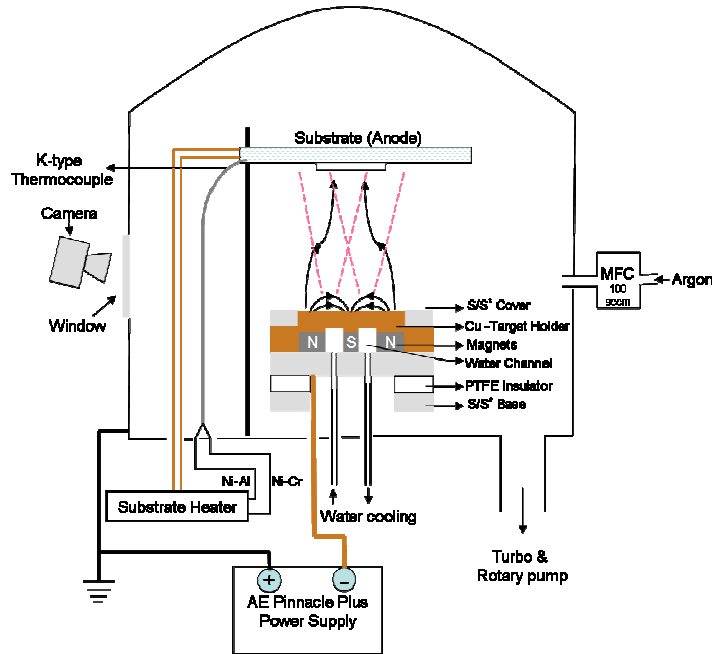

Figure 3 Schematic of Pulsed D.C. Sputtering system

A simplified schematic of the PDMS system is shown in Figure 3. The system consisted of a cylindrical stainless steel vacuum chamber, pumped with a turbo molecular pump backed by a rotary pump. A two-inch unbalanced circular magnetron served as the target head using the powdered polycrystalline CIS as a target source. CIS powder, crushed from polycrystalline ingots, was lightly tamped into the target plate to a depth of around 2 mm. An Advanced Energy Pinnacle Plus pulsed D.C. power supply operated in constant current mode was used to supply power to the cathode. The system pressure was monitored using a capacitance manometer pressure gauge. The system was pumped to obtain an acceptable base pressure of 5.5×10^{-6} mbar. The operating pressure of 7.5×10^{-3} mbar was set and controlled using an MKS argon mass flow controller. Films were deposited on glass microscope slides that had been cleaned using isopropyl alcohol and acetone in an ultrasonic bath.

The films were grown from powders with different starting atomic compositions. The surface morphology and the atomic percentage of the individual base elements were analysed using a Philips XL 30S SEM equipped with an EDX detector. The semiconductor type was established using the hot point probe method and conductivity measurements were carried out with a four point probe. The thickness measurements

were performed using a Dektak 3M profilometer and cross sectional SEM views of films. The structural characterisation was carried out with a SIMENS D 5000 x-ray diffractometer.

3. Results and Discussion

3.1 Polycrystalline CuInSe_2 powder

Polycrystalline CuInSe_2 ingots with different compositions were analysed using EDX to obtain the atomic percentages tabulated in Table 1. The samples were taken from three different positions along the length of the ingot. It was found that the composition was nearly the same for all the positions from the same batch. This verified the uniformity of the samples throughout the ingot and testified to the efficiency of the rocking technique. Results are also shown for one batch of previously prepared CuInSe_2 powder (CISRF00H).

Table 1 EDX results of CuInSe_2 polycrystals

Sample Name	Mixing Percentage	Atomic Percentage (EDX)		
		Cu%	In%	Se %
CISRF00H	unknown	19.95	34.10	45.95
CISRF006	25:25:50	23.02	23.32	53.66
CISRF007	5% extra Se	21.54	24.29	54.17
CISRF009	5% extra In	20.53	27.97	51.50

The crystals were carefully ground into powder and the structural properties of the powdered samples were analyzed using a SIEMENS D 5000 x-ray diffractometer, as shown in Figure 4.

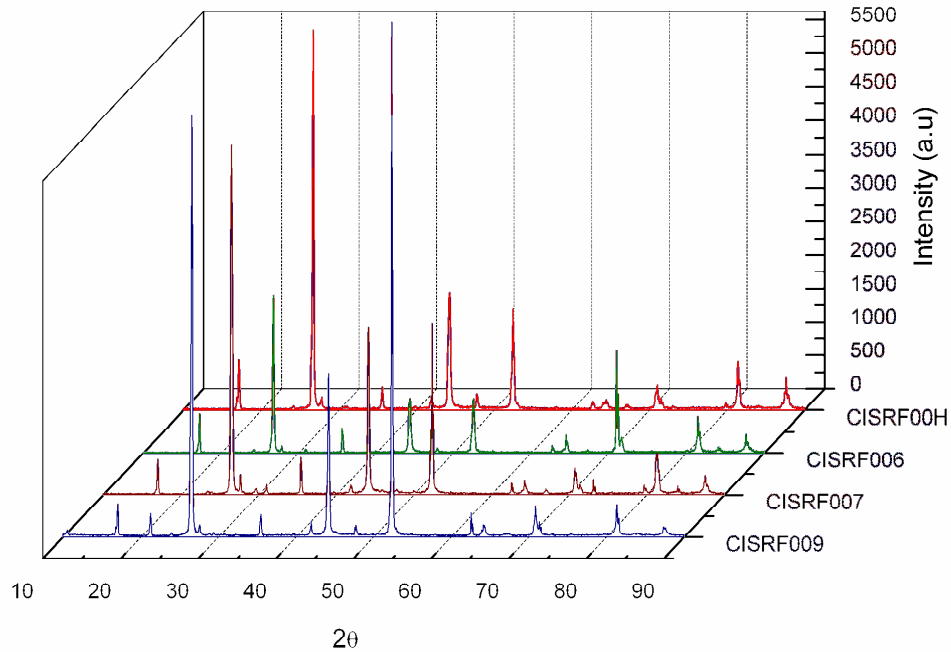

Figure 4 The x-ray diffraction spectra of CuInSe_2 powder

The peak position of sample CISRF006 exactly matches with the JCPDS data for CuInSe_2 (CAS No: 40-1487). The selenium rich CISRF007 has extra low intensity peaks at 2θ of 23.64° and 29.71°. The indium rich CISRF009 has a peak at 2θ of 21.27° but there is no data available to match this point. The chalcopyrite characteristic lines (101) at 17.15°, (103) at 27.70° and (211) at 35.5° are present in all the samples. These peaks verify that the crystals are in the α - phase (Lachab et al., 2005;474-82).

Two sets of films were deposited from each powder with different sputtering times. The power supply was operated in constant current mode at 0.12 A. The frequency was set to 130 kHz with a pulse off time of 1 μs . The operating parameters are listed in Table 2.

Table 2 Operating parameters of the sputtered sample

Sample Name	Starting Material	Voltage (V)	Power (W)	Time (hr)
CIST104	CISRF00H	385	45	4
CIST105	CISRF00H	384	45	5
CIST111	CISRF006	358	43	5
CIST112	CISRF006	352	42	4
CIST113	CISRF007	364	44	4
CIST114	CISRF007	365	44	5
CIST115	CISRF009	368	44	4
CIST116	CISRF009	370	44	5

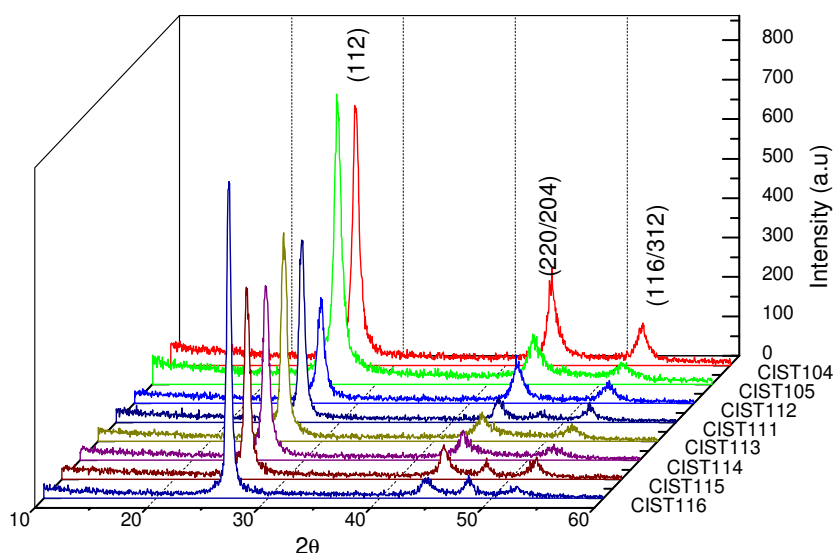

Figure 5 The x-ray diffraction spectra of CuInSe_2 films

The XRD structural analysis (Figure 5) revealed the presence of three prominent peaks corresponding to the planes (112), (220/204), (116)/(312) at 2θ equal to 26.6°, 44.1° and 52.3° respectively, (Figure 4). Samples made from indium rich powder (CISRF009) exhibited an extra peak corresponding to the (301) plane at 47.87°.

The atomic percentages of the films were analyzed using EDX. The atomic percentage values of each element are tabulated in Table 4. The conductivity type was determined with the hot point probe method. Interestingly, all the samples were shown to have p-

type conductivity. p-type CIS thin film based solar cells have always been shown to have a higher efficiency compared with corresponding n-type based cells (Haneman, 1988;377 - 413). The thickness of the samples was measured using a Dektak profilometer and also using SEM cross sections for samples CIS105, 111, 114 and 116. The thicknesses were nearly equal, with an error of ± 30 nm. The corresponding resistivities are listed in Table 5. The resistivities of the samples are measured using four point probe listed in Table 5.

Table 5. Compositional and conductivity analysis of CIS films

Sample Name	Atomic Percentage (EDX)			Conductivity type	Thickness μm	Resistivity (ρ) $\Omega\text{ cm}$
	Cu%	In%	Se %			
	CIST104	23.03	23.48			
CIST105	22.06	24.15	53.79	p	1.203	0.0823
CIST111	23.97	23.62	52.41	p	1.170	0.0321
CIST112	24.32	23.43	52.25	p	0.872	0.0379
CIST113	21.97	23.78	54.25	p	1.440	0.0520
CIST114	22.66	23.62	53.72	p	1.750	0.0469
CIST115	24.78	22.98	52.24	p	1.330	0.0620
CIST116	24.40	23.22	52.38	p	1.730	0.0526

The starting powder compositions and corresponding final film compositions were compared with the help of a ternary diagram, shown in Figure 6. This illustrates the observation that the films' composition is largely independent of the starting powder atomic composition and that the resulting films were nearly stoichiometric. This result shows the importance of employing pulsed D.C. magnetron sputtering as a single step process that can produce the desired p-type CIS films with nearly stoichiometric compositions without an associated selenisation process.

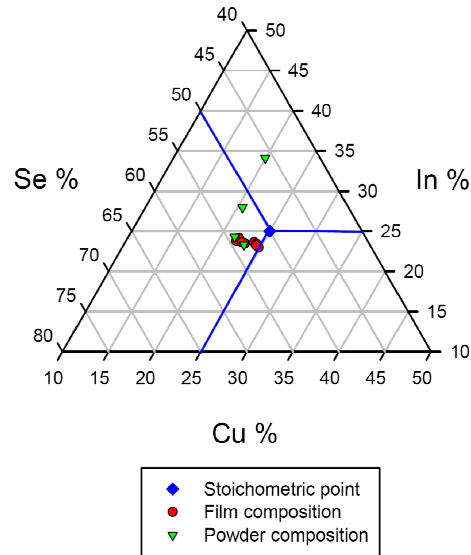

Figure 6. Ternary graph of the starting powder compositions and the final film composition

The surface morphology of the samples was analyzed by SEM. The images of three samples sputtered from different powders are shown in Figure 7. A cross sectional view is also shown. Larger particles sizes were obtained from CIST111 and CIST116 which were deposited from the stoichiometric powder and indium rich powder, respectively. The average particle size of the samples was in the 180-210 nm band. The SEM image showed that the films deposited from the stoichiometric powder and indium rich powder exhibited the largest particle size. The SEM analysis shows some angular structure in the particles and hexagonal, pentagonal and triangular shapes are clearly visible. The cross sectional image shows the columnar growth of the film.

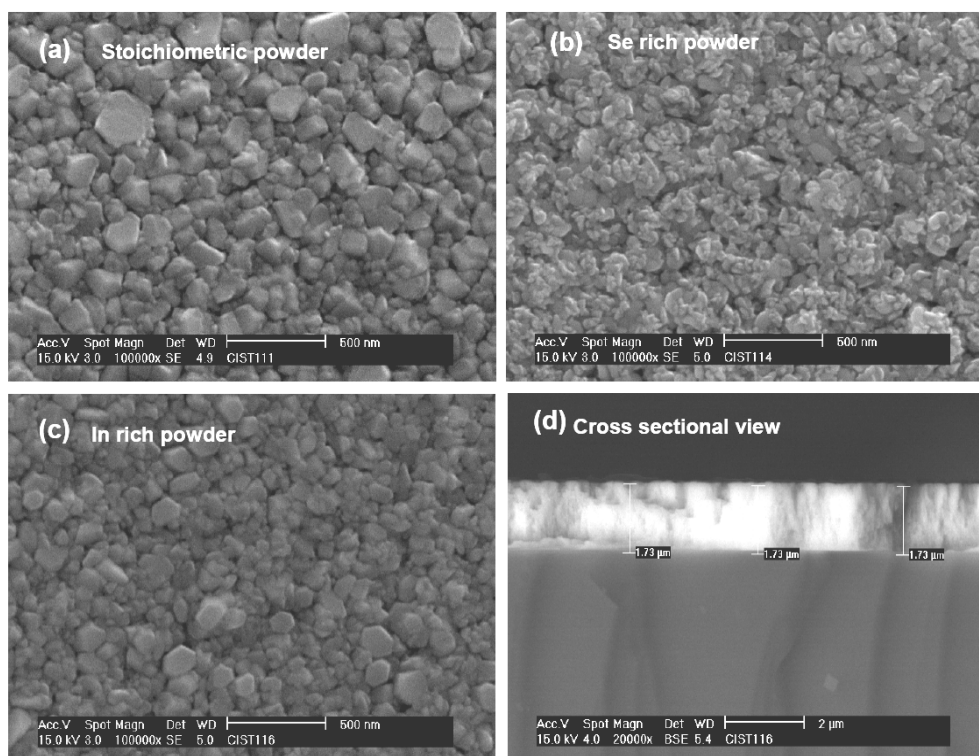

Figure 7 SEM images of the CIS films deposited from different powder (a) from stoichiometric powder (b) Se rich powder (c) In rich powder (d) cross sectional view.

4. Conclusion

The possibilities of pulsed D.C. magnetron sputtering for the deposition of CuInSe₂ films from powdered samples were studied. Polycrystalline CIS crystals were produced in a rocking furnace by the direct fusion of the base elements. XRD analysis shows that these crystals were in the α -phase. Some unknown peaks are seen in the 5% extra In and Se cases which could be due to secondary phases. CuInSe₂ films were deposited from polycrystalline powders of different atomic compositions using a single step pulsed D.C. magnetron sputtering process at room temperature. XRD analysis shows that the films have preferred growth in the (112) direction with no secondary phase. All the films were pin-hole free and showed p-type conductivity. Films were found to be near stoichiometric, largely irrespective of the starting composition of the material. The near stoichiometric nature of the films grown from this single step process can cut down the cost and the use of a post deposition selenisation process. The use of powdered targets avoids the cost of making solid CIS targets with a hydraulic press.

Future work will aim to improve the sputtering rate with an improved target holder design and also study the electrical and optical properties of these films as a function of different substrate heating and biasing conditions.

Acknowledgement

The authors gratefully acknowledge the Joule Centre for the funding of this project. Sincere thanks are due to the Higher Education Funding Council for England (HEFCE) for the award of a research fellowship to Sreejith Karthikeyan under the ORSAS programme. The authors gratefully acknowledge Dr. J.Hinks, Materials and Physics Research Centre, University of Salford for his expert guidance in preparing the CIS crystals.

5. References

- Amara A, Ferdi A, Drici A, Bernède J C, Morsli M and Guerioune M 2006 Electrical and optical study of Cu(In, Ga)Se₂ co-evaporated thin films *Catalysis Today* **113** 251 -6
- Bekker J, Alberts V and Witcomb M J 2001 Influence of selenization techniques on the reaction kinetics of chalcopyrite thin films *Thin Solid Films* **387** 40-3
- Deok Kim S, Kim H J, Hoon Yoon K and Song J 2000 Effect of selenization pressure on CuInSe₂ thin films selenized using co-sputtered Cu-In precursors *Solar Energy Materials and Solar Cells* **62** 357-68
- Durný R, Hill A E and Tomlinson R D 1980 Preparation of amorphous CuInSe₂ thin films *Thin Solid Films* **69** L11-L3
- Goetzberger A and Hebling C 2000 Photovoltaic materials, past, present, future *Solar Energy Materials and Solar Cells* **62** 1-19
- Haneman D 1988 Properties and applications of copper indium diselenide *Critical Reviews in Solid State and Materials Sciences* **14** 377 - 413
- Jones P A, Jackson A D, Lickiss P D, Pilkington R D and Tomlinson R D 1994 The plasma enhanced chemical vapour deposition of CuInSe₂ *Thin Solid Films* **238** 4-7
- Kelly P J and Arnell R D 1998 Development of a novel structure zone model relating to the closed-field unbalanced magnetron sputtering system *Journal of Vacuum Science & Technology A: Vacuum, Surfaces, and Films* **16** 2858-69

Lachab M, Attia A A and Llinarès C 2005 Study on the properties of CuInSe₂ ingots grown from the melt using stoichiometric and non-stoichiometric charges *Journal of Crystal Growth* **280** 474-82

Mudryi A V, Gremenok V F, Victorov I A, Zalesski V B, Kurdesov F V, Kovalevski V I, Yakushev M V and Martin R W 2003 Optical characterisation of high-quality CuInSe₂ thin films synthesised by two-stage selenisation process *Thin Solid Films* **431-432** 193-6

Niki S, Makita Y, Yamada A, Hellman O, Fons P J, Obara A, Okada Y, Shioda R, Oyanagi H, Kurafuji T, Chichibu S and Nakanishi H 1995 Heteroepitaxy and characterization of CuInSe₂ on GaAs(001) *Journal of Crystal Growth* **150** 1201-5

Palilis L C, Lane P A, Kushto G P, Purushothaman B, Anthony J E and Kafafi Z H 2008 Organic photovoltaic cells with high open circuit voltages based on pentacene derivatives *Organic Electronics* **9** 747-52

Pamplin B and Feigelson R S 1979 Spray pyrolysis of CuInSe₂ and related ternary semiconducting compounds *Thin Solid Films* **60** 141-6

Piekoszewski J, Loferski J J, Beaulieu R, Beall J, Roessler B and Shewchun J 1980 RF-sputtered CuInSe₂ thin films *Solar Energy Materials* **2** 363-72

Rockett A, Lommasson T C, Campos P, Yang L C and Talieh H 1989 Growth of CuInSe₂ by two magnetron sputtering techniques *Thin Solid Films* **171** 109-23

Salviati G and Seuret D 1983 N- and p-type CuInSe₂ thin films deposited by the flash evaporation *Thin Solid Films* **104** L75-L8

Song H K, Kim S G, Kim H J, Kim S K, Kang K W, Lee J C and Yoon K H 2003 Preparation of CuIn_{1-x}Ga_xSe₂ thin films by sputtering and selenization process *Solar Energy Materials and Solar Cells* **75** 145-53

Staebler D L and Wronski C R 1980 Optically induced conductivity changes in discharge-produced hydrogenated amorphous silicon *Journal of Applied Physics* **51** 3262-8

Subbaramaiah K and Sundara Raja V 1992 Structural and optical properties of spray-deposited CuIn(S_{1-x}Se_x)₂ thin films *Thin Solid Films* **208** 247-51

Tang C W 1986 Two-layer organic photovoltaic cell *Applied Physics Letters* **48** 183-5

Tomlinson R D 1986 Fabrication of CuInSe₂ single crystals using melt-growth techniques *Solar Cells* **16** 17-26

Attitudes of staff members towards the embracing of Electronic Learning at the Libyan Higher education

Abdulbasit S. Khashkhush, University of Salford

Abstract

Technological innovations have not only brought benefits to business, but to Higher Education, worldwide. Colleges and universities are using E-learning to make learning more accessible and efficient. This paper assessed the attitudes of staff member towards challenges to embracing e-learning. However, Libya is a very wide State and the distribution of the population is concentrated in certain & specified areas make the academic education sometimes difficult either due to distance from the educational centres or due to lack of time or due to handicapped body or others. E-Learning system enables students of all ages and abilities the chance to learn anywhere, at any time and at their own pace. This paper aims to shed light on the role of e-Learning in the Libyan Education System and how it can be improved as well as discussing in general the effectiveness of this system in Libyan higher education by focusing on the factors that affect the up take of this system in Libya. Nevertheless, in this paper the semi-structured interviews with the senior leaders within two universities had been used to identify the factors that affect e-Learning. The paper concludes that at present “e-Learning” does not apply. Nevertheless this is not to say that it cannot be achieved in the future. It suggests that e-Learning requires a minimum technological platform. However, this paper focuses on two public universities (Elfateh University and the Seventh of April University, and hence the generalisation of the findings outside of these universities cannot be validated. However, the paper’s findings appear to be intuitively generalisable beyond the subject topic.

This paper can support capacity building in e-Learning systems in Libya by the identification of needs, which is an important initial stage in any capacity building programme. Overall this is an original approach to the evaluation of the status of e-learning in Higher Education (HE) in Libya.

Keywords

Attitudes towards e-learning, ICT infrastructure, e-learning Factors, Libyan Higher Education,

1. Introduction

The World has been seeing rapid changes in all aspects of life. All countries have been Subject to fierce competition in almost all aspects of life including economic, and educational, along with the information technology revolution which achieved major shifts in improving computer applications, such shifts resulted in improving the competitiveness of the future graduates in the fields of construction & enterprise. In order to improve the competitiveness of the coming generations, traditional education should be revised and further developed through designing and introducing new educative programs using developed ICT facilities. Despite the importance of E-Learning in higher education (HE) and human development in Libya, implementation of E-learning is facing a number of challenges in Libyan universities. Those challenges can be summarized as follows: Leadership; ICT infrastructure; Finance; Culture; Instructors & learners; Lack of Strategy; and Technical expertise. Regardless of these challenges the future is optimistic, offering innovative and advanced opportunities to implement e-learning.

The E-learning program, if established in Libya, will help to solve the problems resulting from a shortage of traditional education institutions that hold an increasing number of students who wish to study at university providing them with a chance to learn and promote scientific cooperation and research in order to reach every individual in the community. E-learning would also provide education for those who missed such opportunities and give provide them with knowledge of technological developments to continue in other areas of technical development.

2. Definition of E-learning

There is a wide range of definitions for E-learning. E-learning offers opportunities to learn anywhere without being in a lecture theatre (Yieke, 2005); E-learning is defined as learning facilitated and supported through the use of information and communications technology. E-learning is no longer simply associated with distance or remote learning, but forms part of a conscious choice of the best and most appropriate ways of promoting effective learning. Khan (2000) defines that E-learning encompasses web-based learning (WBL); internet-based training (IBT); advanced distributing learning (ADL); and online learning (OL). More simply, E-learning can be thought of as anything that incorporates technology with interactivity to support learning, training and communication among groups and between individuals.

Basically, technology has given us the opportunity to learn anywhere, anytime, and at our own pace. Additionally E-learning is using technology to deliver learning and training programs (Knowledge passed through the internet, network, or standalone computer). Therefore it is any technology-mediated learning using computers whether from a distance or in a classroom setting.

2.1. Higher Education context in Libya

Libya is an Arab country located in Northern Africa and it covers a land area about 1,759,540 sq km. The capital of Libya is Tripoli and the main language spoken is Arabic. Italian and English languages are widely understood in the major cities of Libya. The total population of Libya is approximately 5.5 million, of which 1.7 million are students; over 270,000 of whom study at the tertiary level (Clark, 2004). El-Hawat (2003) reported that in the academic year 1975/76 the number of university students was estimated to be 13,418. This number has increased to more than 200,000 of which about an additional 65,000 students enrolled in the higher technical and vocational sector. The consequence of this rapid increase in the number of students in HE in Libya has resulted in an increase in the number of institutions providing HE. The university sector in Libya started in the early 1950s with the establishment of the “Libyan University”. It has campuses in Benghazi and Tripoli and it has grown over the years to incorporate Faculties of Arts and Education; Faculty of Science; Faculty of Economics and Faculty of Commerce, Law, and Agriculture.

Libya has a history of sending university students abroad. In 1978, more than 3,000 students were studying in the United States alone. However, by 2002 those figure had dropped to just 33 as a result of sanctions imposed in 1986, which restricted travel to the United States by Libyan nationals. According to the British Council (British Council Press Release, 2003) the United Kingdom signed a cultural agreement with Libya at the end of 2003 which is expected to result in an increase in the number of Libyan students studying in the UK. Officials from the British Council estimate that there were more than 3000 Libyan students enrolled at British institutions of higher and further education in 2004; of those, 90 percent are said to be on Libyan government scholarships. (Clark, 2004).

3. Methodology

This study was conducted in Libya during the period from August to September 2009. Involving two main universities in Libya, Elfateh university and seventh of April university. Each university was visited by the author, conducting face to face Semi-structured interviews. Observation and the collection of supporting documentation will also be utilized for triangulation purposes. The numbers of interviewees in the two case study organisations were 16 in case study “A” and 15 in case study “B”, Table (1).

Table 1. Interviewee groups from the two case study organisations

Position of the interviewees	Referred in the findings	Case Study “A”	Case Study “B”	Total each level
Dean of the Faculty, Registrar and Administrative manager	Senior Leader (SL)	3/3 “One from each level”;	3/3 “One from each level”;	6;
Heads of Academic Departments	Heads of Academic Departments (HODs)	6/12;	6/9;	12;
Staff member	Academic staff and administrations’ office (STM)	7;	6;	13;
Total each cases	---	16.	15	31

Analysis of attitudes towards major challenges in applying E-learning: In this paper, the attitudes of staff members were identified through data collection. How these attitudes would affect the implementation of E-learning is as follows:

4. Leadership support

The transition from traditional delivery methods to the implementation of E-learning environments inevitably involves the management of change (Betts, 1998). The need for support from an organization's leaders in order to begin and maintain any new approach to learning is addressed in the works of Abdelraheem (2006) and McPherson and Nunes (2006). Moreover, Liaw et al. (2007) went further by stating “instructors' leadership is a crucial factor to affect learners' attitudes to implement E-learning”. If leadership fails to understand currently emerging futuristic technologies and their

potential to develop a vision and strategy to support and enhance learning, acceptance of E-learning will be slow if not impossible (Minton, 2000).

From the viewpoint of the interviewees commitment and support by the leadership is one of the most important factors. The adoption of a new way of doing business or of a new technology is unlikely to succeed if it does not have widespread organizational support, and especially if it does not have acceptance from the leadership. The project that has considerable support gives the people who are working on implementing the project more confidence that the project will proceed to a successful conclusion. This study concluded, after analysis, that leadership support is an important factor for e-learning implementation in the Libyan Higher Education.

This study concluded that SL support is important for all e-learning implementation stages. Furthermore, HOD and STM can play a major role in the implementation of e-learning initiatives. The positive commitment, enthusiasm and support from all three levels for the implementation of e-learning are crucial for both Faculties and Universities to deal effectively and efficiently with new concepts, processes and/or technologies. This factor has been reported by many authors (among them Nunes (2006). Participants from the two categories (HOD and STM) have acknowledged that previous projects had been successful when supported by a senior leader.

The author saw in both cases that there was a lack of knowledge among a few on the SL level generally on e-learning concepts, which makes e-learning less effective if implemented. Therefore, this study suggests that in order to gain support and acceptance from senior leaders, it is crucial for them to understand the issue and what it can provide for higher education. Moreover, they need to know what the project requires and how to implement it.

5. Technological infrastructure

Lack of public awareness on ICT and weak data communications infrastructures are two of the main factors affecting E-learning (Karmakar and Wahid, 2007). An organization that wants to implement E-learning should attain at least the minimum hardware requirements and the software required. The hardware part of E-learning includes the physical equipment that must be present to supply E-learning, e.g., servers and networks (O'Neill et al., 2003; Ettinger et al., 2006). O'Neill et al. (2003) suggested that the success of the technological infrastructure also has implications for the success of virtual learning; malfunctioning hardware or software can both be barriers which

can cause frustration and affect the learning process. Valentine (2002) agreed with O'Neill et al. that hardware and tool malfunctions can be greatly detrimental to the effectiveness of E-learning.

Another important factor covered within this paper is the required technology infrastructure to implement E-learning in Libyan higher education. The data from the interviews revealed that interviewees in Case "A" (with a reasonably established infrastructure) were willing to implement E-learning initiatives; while interviewees in Case "B" (which lacked appropriate infrastructure) wanted to participate in the implementation of E-learning initiatives. To be successful such a programme needs to have an infrastructure that is capable of supporting and enabling the execution of E-learning.

Therefore, this paper suggests that the Higher Education in Libya needs to have in place good quality technology in all universities. At the moment in terms of technology there is a dissimilarity between the two case studies; for example, Case Study "B" has shortages of computers despite the fact that they have a plan to fully computerize the university as a part of their effort to develop a technological culture which encourages and promotes the use of technology in day-to-day activities and tasks.

The requirement for this technological infrastructure was identified by respondents as an important part of their work, and as a basic need to launch E-learning programmes. The study data showed that Case Study "A" enjoyed the best technological infrastructure capability, while Case Study "B" showed the lowest standard of technological infrastructure, but the author expects the level of technology use among Libyan Staff member will increase in coming years, as the plan is to provide the university in Case Study "B" with computers and sufficient technology.

6. Funds

The consideration of the initial cost as well as the continuing costs of installing, maintaining, using and upgrading technology, and the human capital costs to support E-learning, is very important (Valentine, 2002). Marengo and Marengo (2005) demonstrated that the costs of technological infrastructure include digital content costs, maintenance costs, content hosting costs, hardware and software costs and costs of E-learning staff. Staff costs include tutoring costs, administration and management costs and Expert in Multimedia Technology (ETM) costs. In addition, Marengo and Marengo (2005) stated that, in cases where the hardware and software supplied by the

faculty to circulate the contents (software, document, etc..) are not sufficient, the E-learning evaluation needs to take into account the cost of items, such as the purchase of a server and its relative software. The lack of money can be problematical for the implementation of E-learning particularly with the continuous labour costs of instructors (Cho and Berge, 2002; James-Gordon et al., 2003; Berge and Muilenburg, 2006).

The majority (87.5%, 14) of the interviewees agreed that the university has enough financial resources to cover the expenses and technical requirements of adopting and providing E-learning (Figure 1). The author found in the interviews that this factor was not of significance to the interviewees. They confirmed that the entire funding for any project comes from a single source; that the government is based on political decision-taking and thus if the universities decide to adopt E-learning, there would be no problem in funding. Only one STM from Case Study “A” responded ‘don't know about the availability’ in answer to this particular question.

Most of the interviewees stated if they wanted to request anything the university is able to afford it. One senior leader from Case Study “A” and another one in the same position in Case Study “B” reported that if a decision is taken on the adoption and implementation of any project, such as E-learning for example, it will be passed together with a budget from the finance sector and that a decision on E-learning implementation must come from the General People’s Committee of HE. The author agrees that this is the system in Libya in all public sectors.

The author concluded that funding is not a significant factor in Libya because if a decision is taken to implement E-learning, funding will be approved by the government, and thus in Libya it is a different scenario to that stated in the literature where other sources say that it is possible that E-learning could be undertaken either by the government or by private investment or by partnership.

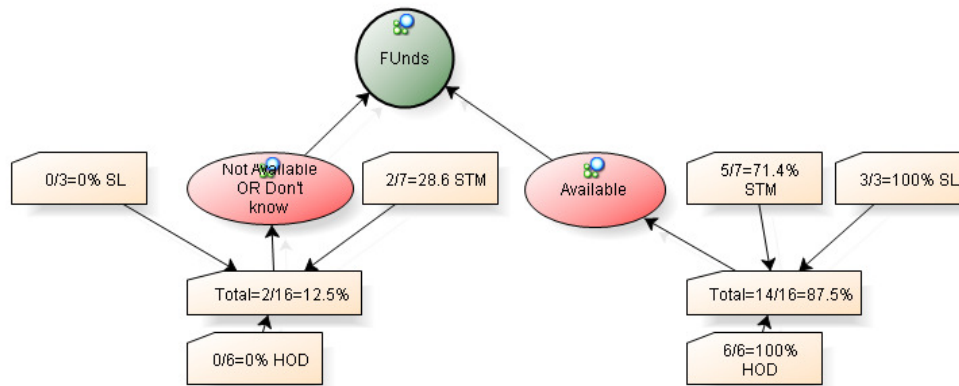

Figure 1. Case Study “A”: Number of respondents who confirmed that funding could be made available.

7. Resistance to changes

Resistance to change is one of the important factors affecting the implementation of E-learning (Minton, 2000; Cho and Berge, 2002; Berge and Muilenburg, 2006; Ettinger et al., 2006). This resistance to change in some countries is usually because of the high percentage of illiteracy in those countries (Karmakar and Wahid, 2007). Moreover, Habibu (2003) stated that resistance to change is one of the factors that should be considered when implementing E-learning. It relates particularly to non-technical issues which includes academic staff, administrators, and/or managers. This resistance can be divided into three main reasons: fear of ICT; lack of time to design, develop and maintain support for online classes’ materials, and fear of exposing the quality of work. Lecturers are one of the major factors that contribute to the success of E-learning. For lecturers, implementation of E-learning programmes represents a change in teaching style and materials. The precise nature of the change is difficult to quantify (O'Neill et al., 2003). O'Neill et al. (2003) stressed that human resources should be committed to the project at an early stage and lecturers should be selected based on their attitude towards technology. According to Liaw et al. (2007) personal attitude is a major factor affecting usage of IT. Understanding a user's attitudes toward E-learning facilities is important for the creation of appropriate E-learning environments for teaching and learning.

The acceptance and implementation of electronic learning involves altering human behaviour and activities. The majority of the respondents (81.3%) agreed that there is a

natural resistance to change for different reasons. The senior leaders believed that their Heads of Department and their staff members resisted change because they fear using technology; because they lack time to design on-line teaching materials; and because E-learning might expose the quality of their work and may lead to a reduction in jobs. Resistance to change and staff culture are important factors affecting the implementation of E-learning. The implementation of electronic learning involves changing individual behaviour and activities and the majority of the respondents agreed that there is a usual resistance to change and adoption of any new technology for different reasons.

In the two case studies, Case Study “A” and Case Study “B”, the majority agreed that the reasons for resistance to change are a lack of time, fear of technology and fear that the staff member is exposing the quality of their work. But some of respondents added other reasons which were: fear of losing their jobs, fear of using the English language and time pressures on their work load.

8. Staff education/training

One of the most challenging factors for STM and universities around the world is technology and the need for continuous training for keeping up-to-date with advanced technology.

Staff education and knowledge is another important factor for the successful adoption of E-learning systems, University staff members need to be aware of the need to continue learning and to utilise IT technological infrastructures to acquire and manage knowledge. Training to use E-learning systems will ensure that they can utilise the full potential and capabilities offered by ICT tools. If universities provided staff with adequate and quality training to facilitate the use of technology and E-learning systems then staff would, in all probability, find E-learning systems easy to use. It is important that universities promote and educate staff to use E-learning systems rather than forcing them to do so.

9. Technical expertise

Lack of personal technological expertise in solving technical problems is one of the main factors affecting an E-learning programme (O'Neill et al., 2003; Berge and Muilenburg, 2006). Valentine (2002) added one overlooked factor in the success or failure of E-learning programmes, i.e. the role that technicians play in E-learning.

The author noted in the findings that there were disparities between Case Study “A” and Case Study “B”. In Case Study “A” it was noted that the most of the answers from SL, HOD and STM indicated that they have some professionals who undertake the maintenance of equipment (for example, computers) and that they also have some expertise in programming, multimedia technology and experts in information technology, and project management. In Case Study “B” most of the answers from the interviewees indicated that there was a shortage of such professionals who can maintain equipment such as hardware and multimedia technology; there was also a shortage of specialists in software programming such as project management and information systems.

10. Strategy

From the literature and the findings, the setting up of a strategy was found to be an important factor for the implementation of E-learning in the Libyan case studies.

This study concluded that the strategy has not only to be directed from the leadership, it also has to be established within each faculty to enable all participants/staff to work towards realizing the goals and objectives of such a programme and to ensure that work is undertaken towards achieving the essential goal of implementing E-learning.

The findings revealed that a strategy for the implementation of E-learning in Libya was non-existent. This was supported by SL, HOD and STM in Case Study “A” and HOD and STM from Case Study “B”. One of the STMs stated that the technology was available and the adoption of E-learning should be a part of the University strategy.

Therefore, this study suggests that Higher Education in Libya needs to have a comprehensive and clear strategic plan to implement E-learning programmes, and the author believes that postgraduate programmes with their fewer students could be used as a pilot for E-learning systems after an E-learning strategy has been introduced.

11. E-learning opportunities for Libya

The future will witness continuous development in utilizing E-learning despite the fact that its impact on the economic status is not evident yet (El Shenawi, 2007). The move towards using technology is no longer a choice or a luxury but rather an emerging need, and hence the developing countries educative policies should go hand in hand with those of the developed countries.

Applying information technology in the Higher Education sector in Libya is considered an opportunity which may affect the quality of final output as well as overcoming the problems of high density in universities. Implementing E-learning applications in Libya can create the following opportunities: saving time, cost and effort; satisfying the educative needs of scholars studying in remote regions and providing opportunities for self education. Empirical studies have proved the optimistic impact of E-learning processes, widening opportunities for lecturers and tutors with regard to the content of the courses in a way that suits and satisfies the needs of the academics. E-learning assists in overcoming problems such as the overwhelming density in universities; it enables the establishment of new faculties and colleges; it overcomes problems such as lack of skills in certain subjects such as languages and computers. It provides a mechanism for collaborative learning between academics.

12. Conclusion

The implementation of E-learning can create enormous changes within a Libyan HE university, so it can expect to face factors such as resistance to change as the institution changes the way instructors teach, managers manage, and reforms are undertaken of the current work process by changing boring routine work, eliminating bureaucracy, and improving transparency.

The factors affecting the implementation of E-learning should be well understood in advance and increasing awareness by the staff in Libyan HE universities must be raised by staff members attending lectures, seminars and conferences. The failure of Libyan HE Institutions to accept and develop a vision and strategy to understand the current emerging advanced technologies will seriously undermine any potential to implement the E-learning process. As a result, training should have a strategy which should be addressed early alongside other strategies and should encourage STM through a motivation and reward system. E-learning requires a minimum technological platform which includes necessary hardware, adequate telecommunication capabilities and access to software. Lecturers should be selected based on their experience, potential and outlook toward new technology. Experts in multimedia technology have to support teachers in the activities of organization and management and, to some extent, the development of E-learning courses as well. The implementation of E-learning programmes represents a change in teaching style and materials.

Acknowledgement

The author would like to thank Prof: David Eaton and Prof Vian Ahmed for valuable comments.

13. References

- Abdelraheem, A.Y., 2006. The implementation of E-learning in the Arab University: Challenges and opportunities. In DLI (Distance Learning and the Internet), *7th Technology Enabled Global Knowledge Structuring*. Tokyo, Japan 8-10 November 2006. Tokyo: Japan.
- Berge, Z., and Muilenburg, L., Y., 2006. *Barriers to distance Education: Perceptions of K-12 Educators*. [Online] Available at: <<http://www.emoderators.com/barriers/barriersK12.html>> [Accessed 21 September 2007].
- Betts, K.S., 1998. An Institutional Overview: Factors Influencing Faculty Participation in Distance Education in Postsecondary Education in the United States: An Institutional Study. *Journal of Distance Learning Administration* [Online] Available at: <<http://www.westga.edu/Edistance/betts13.html>> [Accessed 28 November 2007].
- British Council Press Release. 2003. *British Council Signs Major Agreement with Libya*. 18 Dec. 2003.
- Cho, S.K., and Berge, Z., 2002. Overcoming Barriers to Distance Training and Education. *Journal of USDLA*, [online]. Available at: <<http://www.emoderators.com/barriers/cho.html>> [Accessed 21 September 2007]
- Clark, N., 2004. *World Education News and Views*. [Online] Available at: <<http://www.wes.org/ewenr/PF/04Jul/PFP/ractical.htm>> [Accessed 02 May 2007].
- El-Hawat, A., 2004. *African Higher Education: An International Reference Handbook*. Indiana University Press, USA.
- Ettinger, A., Holton, V., and Blass, E., 2006. E-learning experience: Key questions to ask when considering implementing E-learning. *Industrial and Commercial Training*, 38 (3), PP. 143-147.
- Habibu, A., 2003. *E-learning Challenges In Africa Case Study Uganda*. [Online] Available at: <<http://cit.mak.ac.ug/staff/jlubega>> [Accessed 30 August 2007].
- James-Gordon, Y., Young, A., and Bal, J., 2003. External environment forces affecting E-learning providers. *Marketing Intelligence & Planning*. 21(3), PP.168-172

- Karmakar, C.K., Wahid, CM. M., 2007. *Prospects of E-learning in the context of current ICT Infrastructure of Bangladesh*, [Online] Available at: <http://www.codewitz.net/papers/MMT_83-89_FullPaper_Wahid_Karmakar.pdf> [Accessed 05 November 2007].
- Khan, B.H., 2000. *A framework for web-based learning*. Englewood Cliffs, NJ: Educational Technology Publications.
- Liaw, S., Huang, H., and Chen, G., 2007. Surveying instructor and learner attitudes toward E-learning. *Computer & Education*, 49 PP.1066-1080.
- McPherson, M. and Nunes, M.B., 2006. Organisational issues for E-learning Critical success factors as identified by HE practitioners. *International Journal of Educational Management*, 20(7), PP.542-558.
- Marengo, A., and Marengo, V., 2005. Measuring the Economic Benefits of E-learning: A Proposal for New Index for Academic Environments. *Journal of Information Technology*, 4, pp.329-346.
- Minton, M.C., 2000. Is Your Organization Ready for E-learning?. *Communication Project Magazine*, [Online] Available at: <<http://www.comproj.com/Minton.htm>> [Accessed 22 May 2008].
- O'Neill, K., Singh, G., and O'Donoghue, J., 2004. Implementing eLearning Programmes for Higher Education: A Review of the Literature. *Journal of Information Technology Education*, 3, pp313-323.
- Valentine, D., 2002. Distance Learning: Promises, Problem, and Possibilities. *Online Journal of Distance Learning Administration*, [Online] Available at: <<http://www.westga.edu/~distance/ojdla/fall53/valentine53.html>> [Accessed 22 December 2007].
- Yieke, F. A., 2005. Toward Alternatives in Higher Education: The Benefits and Challenges of E-learning in Africa. *CODESRIA Bulletin*, 3(4), PP.73-75.

Detection of *Echinococcus granulosus* in farm dogs in South Powys, Wales using coproELISA and coproPCR

Wai-San Li¹, Belgees Boufana¹, Helen Bradshaw¹, Arjen Brouwer², David Godfrey³, Philip S. Craig¹.

School of Environment and Life Sciences, University of Salford¹

OCVO²

LVI Locums Ltd³

Abstract

Echinococcus granulosus is a dog tapeworm that causes the zoonotic disease, cystic echinococcosis. Echinococcosis in dogs appears to have re-emerged in Powys, Wales following a control programme in the 1980s (Buishi et al., 2005). The Office of the Chief Veterinary Officer and the Department for Public Health and Health Professions in the Welsh Assembly Government jointly funded a pilot dog worming campaign as a preventative public health measure. To evaluate the impact and efficiency of a short-term supervised dog dosing scheme, collection of faecal samples on farm visits and worming of dogs with praziquantel commenced in south Powys in May 2008. In Year 1, approximately 1500 canid faecal samples were collected from registered farms and delivered to the University of Salford to be tested. In total 1351 faecal samples were tested by coproELISA³, of these 609 samples were collected at baseline and were found to have a coproantigen prevalence of 10.8% (66/609). A total of 742 samples collected and tested after 3 months since previous treatment gave a coproantigen prevalence of 0.7% (5/742). Out of the 71 samples that tested coproantigen positive, 7 were shown to be coproPCR positive. The study will continue to compare the coproantigen positivity over three consecutive yearly quarters after cessation of dosing.

1. Introduction

Echinococcus species is a group of parasitic tapeworms of canids and other carnivores. Unlike other taeniid tapeworms they are only 2-7mm in length.

³ Copro' refers to samples that have derived from faecal origin

The anterior section is called the scolex, which has hooks and suckers that help it to attach to the intestine of its host. The tapeworm has 3 or 4 segments (proglottids) of which the last is gravid. The primary host or definitive host of *E. granulosus*, where the adult tapeworm resides is usually the small intestine of domestic dogs (*Canis familiaris*) and other canids. The intermediate host is where the larval cystic form (metacestode) of the parasite lives and can be one of a large number of mammalian species including domestic ungulates and humans. Echinococcosis, also known as hydatid disease, is a term used to describe infection in humans or other intermediate hosts. Cystic echinococcosis (CE) is caused by *E. granulosus* and presents non-specific symptoms, making it difficult to diagnose as clinical signs may take months to years to develop and only become apparent as the metacestode grows. The beginning of primary infection is always without symptoms and up to 60% of all CE cases may be asymptomatic (McManus et al. (2003). It is uncertain how long the incubation period of CE is, however it has been suggested that it may be from many months to years. Patients presenting symptoms can do so at any age but usually in older age groups (WHO/OIE, 2001). Most research shows that infection rates are very similar in both males and females.

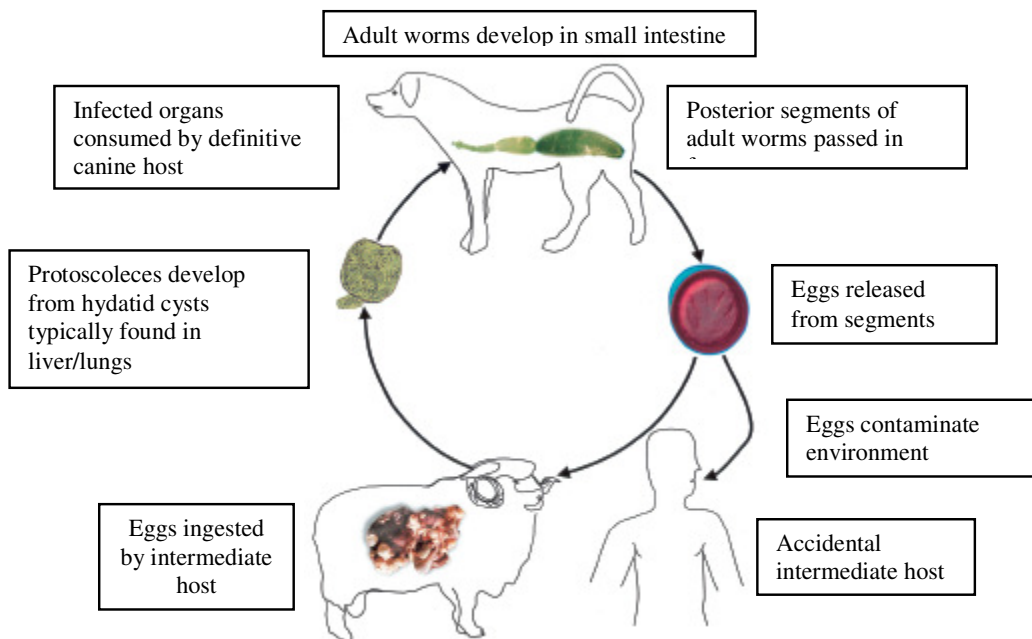

Figure 1. Life cycle of *E. granulosus* (Zhang et al., 2003 - modified by author).

Humans have been described as ‘dead-end’ hosts for the parasite, since the life cycle usually relies on carnivores eating infected herbivores (McManus et al., 2003, Zhang et al, 2003). However, there may be rare circumstances, for example in the Turkana region of northwest Kenya, where humans do not bury their dead and dogs and wild carnivores are able to scavenge from the human remains. Under these circumstances if the corpses harbour viable cysts, then humans can also serve to complete the life cycle of *Echinococcus* (Macpherson, 1983).

E. granulosus infection has re-emerged in several parts of the world where it was once believed to be controlled or at low prevalence (Moro & Schantz 2009). Between 1993 and 2002, the prevalence of infected dogs by coproELISA in south Powys, Wales has more than doubled from 3.4% to 8.1%, following policy changes favouring health education and advocating dog owner responsibility for anthelmintic preventative treatment over 6 weekly dosing of dogs with praziquantel (Buishi et al., 2005). Canine echinococcosis therefore appears to have re-emerged in south Powys, Wales, following a successful 6-7 year control programme between 1983 and 1989 (Buishi et al., 2005). On the 19th May 2008, farm visits and worming of dogs commenced in south Powys (Brecknockshire and Radnorshire). The Office of the Chief Veterinary Officer and the Department for Public Health and Health Professions in the Welsh Assembly Government jointly funded a pilot dog worming campaign as a preventative public health measure. A random selection of farms have had their dogs tested by coproantigen ELISA for *E. granulosus* to evaluate the impact and efficiency of the supervised free dog dosing with praziquantel (Brouwer and Willson, 2008).

2. Materials and methods

Over a 12 month period, approximately 1500 canid faecal samples were collected from farm dogs as ground samples and delivered to the University of Salford to be tested. They were delivered in batches (1-7). These samples included spare samples in case chosen samples were unviable. In total 1351 samples were tested by coproELISA. Faecal samples were placed in a -80°C freezer for at least 3 days to kill any infective eggs. This was to ensure maximum safety to the researcher when handling faecal matter during the processing stage. After 3 days the samples were stored in a -20°C freezer until required.

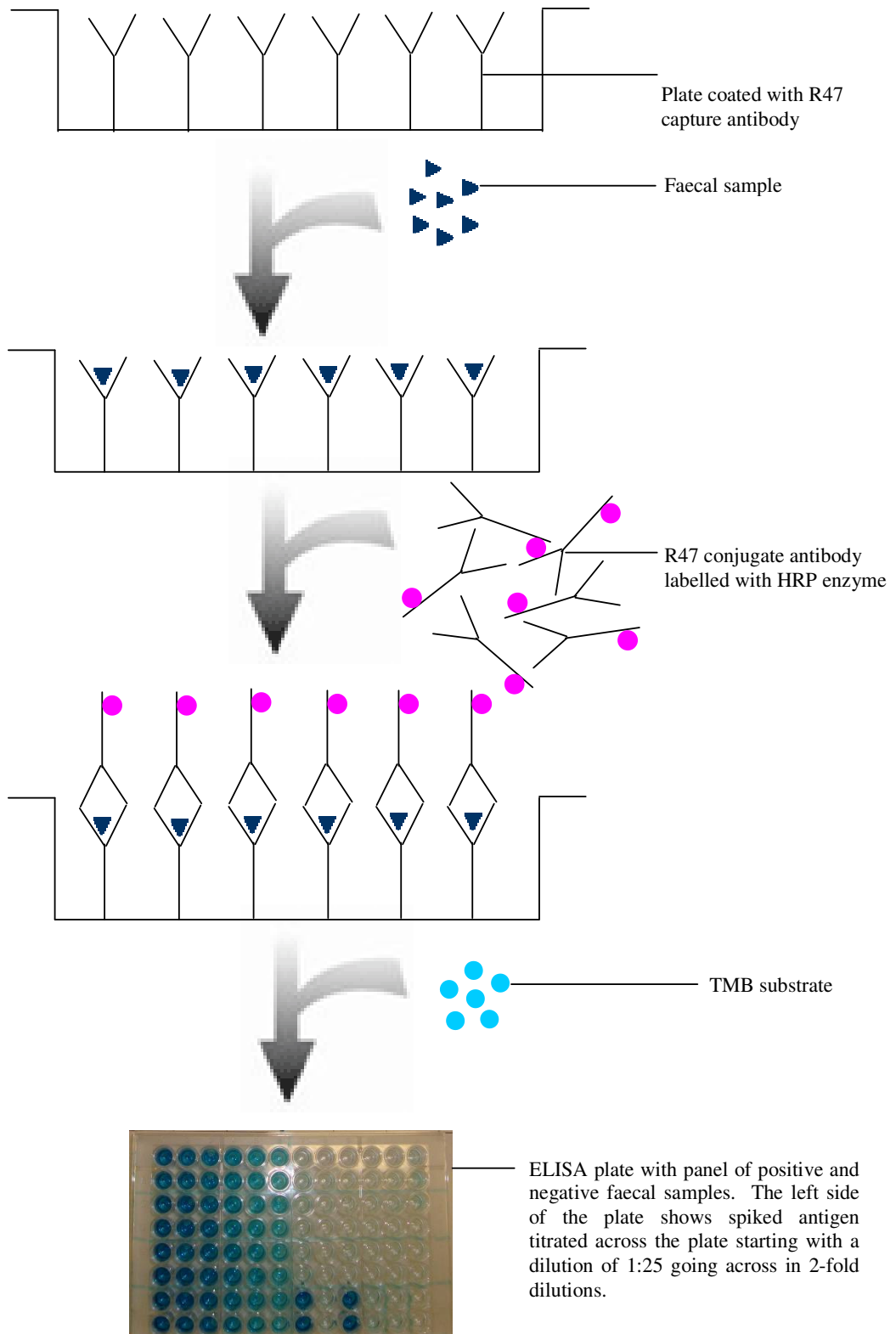

Figure 2. Antibody-antigen binding of the ELISA assay.

3. CoproELISA processing

ELISA refers to an immunological technique called Enzyme-linked Immunosorbent Assay. To set up a diagnostic coproELISA, polyclonal antibodies are raised in a small mammal i.e. a rabbit, by injecting extracts of the desired parasite. The antibodies that are subsequently raised are then processed to produce a capture antibody and a detection antibody (Allan et al., 1992). The detection antibody is usually conjugated to an enzyme such as horse radish peroxidase (HRP). HRP reacts to a substrate solution i.e. tetramethylbenzidine (TMB) giving a detectable colour which can then be read by a plate reader to give numerical data in the form of optical density (OD) values (Buishi et al., 2005). Figure 3 describes how the antibody-antigen binding of the ELISA assay works.

The samples were processed to prepare them for coproELISA testing. The required samples were defrosted for 2 hours at room temperature. Each sample was provided with 1x 5ml bijou and 1x 2ml Eppendorf, which were pre-labelled with lab ID and dog name (if applicable). Once the sample had defrosted, 0.5g – 1g of faeces was removed from the original tube and placed into a 5ml Bijou using a clean wooden spatula. The 5ml bijou was topped up with 0.3% PBSt20. The faeces and 0.3% PBSt20 were thoroughly mixed with the wooden spatula, sealed, shaken then centrifuged at 2500rpm for 5 minutes. The supernatant was tipped into a labelled 2ml eppendorf. The remaining Bijou and contents were disposed of and the supernatant was frozen at -20°C until required.

4. CoproELISA protocol

The protocol is essentially that described by Allan et al. (1992) and Buishi et al. (2005). To summarise, an Immulon 4HBX plate (Thermo Electron Corporation) was coated overnight with a working dilution of capture rabbit antibody - anti [EgWWE-IgG \(whole worm extract\) at a 1:8000](#) dilution in bicarbonate coating buffer (BCB).

The following day the plate was washed three times with 0.1% phosphate buffered saline – Tween 20 (PBSt20). 100µl of 0.3% PBSt20 was added to each well and the plate incubated for one hour on the bench at room temperature. The plate contents were discarded and 50µl of heat-inactivated foetal calf serum (HI FCS) was added to each well, then 50µl of faecal supernatant in duplicate was added. A selection of positive and negative controls was used during each assay to confirm assay viability.

The plate was then incubated at room temperature for one hour on an orbital shaker. A working dilution of rabbit anti-E.gWWE-IgG – PX conjugate at 1:2000 in 0.3% PBSt20 was prepared. The plate contents were discarded and rinsed three times with 0.1% PBSt20 as before and 100µl of the conjugate was added to all wells except the blanks. The plate was incubated for one hour at room temperature on an orbital shaker. The plate contents were discarded, rinsed three times 0.1% PBSt20 as before and 100µl of the TMB substrate solution (Pharmingen, TMB substrate) was added to each well, including the blanks and placed in a dark cupboard for 20 minutes to develop. The plate was read at 20 minutes using wavelength 630nm.

5. CoproDNA extraction

DNA extraction was carried out using the Qiagen QIAmp® DNA Stool Mini Kit (Qiagen House, West Sussex, UK). The DNA samples were stored at 4°C until required.

6. CoproPCR protocol

The *E. granulosus* PCR protocol was carried out as outlined by Abbasi et al. (2003), however ‘the reagent concentrations quoted in the Abbasi protocol did not provide optimal results’ (Boufana et al., 2008) therefore reagent concentrations used were slightly modified from those quoted in the original article. These were 250µM (each) of dNTPs, 1µM of each primer and 2% formamide. The Strategene® Robocycler 96 (La Jolla, CA) was used for all cycling profiles.

PCR amplicons were subjected to electrophoresis on a GelRed™ stained 1.5% agarose gel in Tris-borate EDTA buffer. A molecular weight marker (HyperLadder I or HyperLadder II, Bioline, London, England) was included on each gel for confirmation of amplicon sizes. Positive controls to monitor PCR success and negative controls to check for false-positive results that may have arisen from carry-over contamination were also included in all experiments. Gels were visualized under UV illumination using a Flowgen Alpha 1220 gel imaging system (Alpha Innotech Ltd., Staffordshire, U.K.) and a photograph was taken to record the results.

Ethanol precipitation and sample dilution. If no bands were visible for suspected positive samples, the DNA extractions were ethanol precipitated. Ethanol precipitation is a commonly used technique for making the DNA more concentrated and removing the salt concentration from the nucleic acid as explained by Oswald (2007). By

precipitating the DNA out of solution, it becomes more concentrated and therefore increases the chance of amplification by PCR.

The ethanol precipitation procedure was carried out according to the following optimised working protocol; the volume of the DNA stock sample was measured. One tenth of this volume of 3M sodium acetate was added to the DNA stock sample. Of this new volume, 2 x of chilled 100% ethanol was added. The samples were placed at -20°C overnight. The following day the samples were centrifuged at 13000 rpm for 20 mins after which point a white pellet may be seen. The supernatant was carefully removed from the side of the tube. The samples were centrifuged for 3 mins. The supernatant was carefully removed. The samples were washed with 100µl of 70% ethanol and vortexed briefly. The samples were then centrifuged for 10 mins and the supernatant was carefully removed. The samples were centrifuged for 5 mins and the ethanol was removed with a fine tip. The samples were left to air dry for 20 mins to remove any ethanol traces. The samples were re-suspended in a one tenth of the starting volume giving a x 10 concentration. The DNA samples were stored at 4°C until required.

7. Results

A total of 609 out of the 1351 dog faecal samples tested were collected in quarter 1 before the administration of the first quarterly supervised free dog worming. The coproantigen results can be seen in Table 1. Out of the 609 baseline samples 10.8% (71/609) were coproantigen positive. Table 1 also shows three studies that were carried out in the area previous to the current study, all of which used similar coproELISA methods as described.

In 1993, 107 unwormed farm dogs in south Powys were coproantigen tested and a 0% coproantigen prevalence was recorded (Palmer et al., 1996). Previously in 1983 a control programme was set up in south Powys to dose farm, hunt kennel and privately owned dogs every 6 weeks with praziquantel, educate farmers and collect data on dogs (Lloyd et al., 1998). The programme was replaced in 1989 by a publicity and educational campaign. Out of 112 farm dogs sampled between 1995-96, 6.3% were shown to be coproantigen positive. Another study was carried out in south Powys to investigate whether the foot and mouth disease (FMD) crisis had an impact on canine echinococcosis following the concern that the large numbers of sheep carcasses lying in fields may have been potentially accessible to dogs and foxes (Buishi et al. 2005).

The study showed that there was no statistical association with FMD-affected farms, however they reported that canine echinococcosis had reemerged in dogs living in previously controlled areas. Out of 928 farm dogs tested, 8.5% were found to be coproantigen positive.

Table 1. CoproELISA results of farm dogs from 1993 to current study

Year	Results	Dogs sampled	Reference
1993	0%	107 unwormed farm dogs	(Palmer <i>et al.</i> , 1996)
1995-96	6.3%	112 dogs from sheep farms	(Lloyd <i>et al.</i> , 1998)
2002	8.5%	928 dogs on sheep farms, selected according to foot and mouth disease status	(Buishi <i>et al.</i> , 2005)
2008	10.8%	609 farm dogs	current study

In the current study coproELISA prevalence in dogs on farms at pre-treatment baseline was 10.8% (66/609). During 3 treatment quarters (9 months) of the dog worming campaign the coproantigen positivity had reduced to 0.7% (5/742).

Table 2. Year 1 coproELISA results. Quarter 1 represents a baseline prior to the official dosing campaign. Quarters 2 - 4 represent positivity during quarterly treatment. Time of sampling approximately 3 months post treatment.

Quarter	Samples tested	CoproELISA +ve	Coproantigen prevalence (%)
1 (Baseline)	609	66	10.8
2-4	742	5	0.7

All of the ELISA positive samples were tested for *E. granulosus* using a PCR assay that amplifies a target repeated sequence (Abbasi *et al.*, 2003). Out of the 71 samples that were coproantigen positive, 7 were shown to be coproPCR positive through the amplification of a 133bp diagnostic fragment.

Defining a cut-off point. It is important to have a cut-off point in an ELISA assay. This allows the researcher to say whether the sample is positive or negative. There must be a point at which an OD value can be seen as positive or negative and it is for this reason that a 'cut-off' point is calculated. A negative control panel of dog samples taken from the UK was used to establish a cut-off point. A selection of positive controls from Salford University stock, were also used to confirm assay viability. The cut off point is then calculated using the following formula:-

Cut-off Point = Mean OD of serum samples + 3 x standard deviation of samples. In the current study the working cut-off point was 0.095.

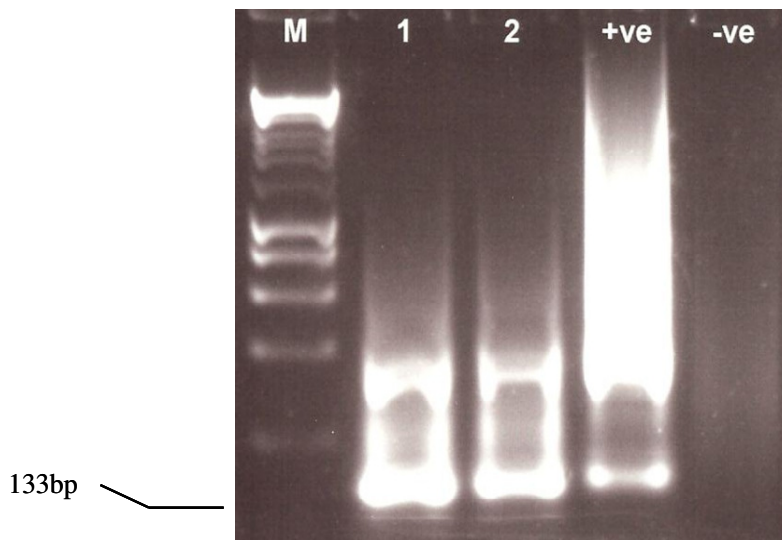

Figure 3. PCR amplification of coproDNA. Lane M, 100-bp molecular DNA ladder; lane 1 and 2, samples from quarter 2; lanes 3 & 4, positive & negative controls respectively.

8. Discussion

Historically south Powys is known to have been a 'hot spot' for *E. granulosus* transmission to humans. Previous to the 1983-1989 control program, 114 farms in Powys were visited twice in 1975, faecal purges were examined and it was found that nearly 60% of farms contained at least one infected dog between the two visits (Walters and Clarkson 1980). The surveillance carried out since 1993 in South Powys and set out above suggested that levels of infection in dogs had declined following the control program of the mid eighties with evidence of a rising trend in prevalence in

2002. The Welsh Assembly Government launched a campaign to raise awareness of the tapeworm in dogs, with the aim of preventing a cross over of infection to humans. The campaign included the provision of free anthelmintic treatment combined with the collection of data and samples as a pilot over one year to evaluate the efficacy, efficiency and practicability of dog anthelmintic treatment as a public health preventative measure. Results suggest that mass dosing in quarter 1 and in the three subsequent quarters has significantly reduced coproantigen prevalence amongst dogs on farms and maintained a low prevalence.

Coproantigen ELISA is a more sensitive (>80%) detection tool than coproPCR but it is less specific (Allan and Craig, 2006). The R47 reagents have been found to be 64% specific in our lab. Gold standard detection of *E. granulosus* in dogs is necropsy which, although highly sensitive and specific, raises ethical issues and is both laborious and biohazardous (Eckert et al., 2001). In our lab, the coproPCR primers that were used in this study are 52.6% sensitive of *E. granulosus* infected dogs but are the most species-specific, cross-reacting only with *Echinococcus shiquicus* giving 75% specificity (Boufana et al., 2008). The coproELISA indicates the presence of the adult tapeworm independent of egg production whereas PCR sensitivity depends on successful DNA extraction of parasite eggs in the faeces. CoproPCR is used as an additional tool to detect the presence of *E. granulosus* in the tested cohort and area. Future work will involve investigating different techniques to isolate and extract parasite eggs from faeces such as flotation, sieving and using glass beads.

The pilot study will continue to use the coproantigen positivity of dogs on a random selection of farms for three yearly quarters after the cessation of free anthelmintic provision in order to establish trends and provide an indication of reinfection rates of dogs.

Acknowledgements

The study was funded by the Welsh Assembly Government and supported by the University of Salford Biomedical Research Institute. I would like to thank Professor P. S. Craig for his support and guidance throughout this project. I would also like to thank LVI Locums Limited operatives Sian Burrows, Sarah Houghton and Rosalind Paramor. Special thanks are given to B. Boufana whose help was invaluable during the laboratory investigations at The University of Salford. And finally, thank-you to SPARC for giving me the opportunity to publish this research.

References

- Abbasi I., Branzburg A., Campos-Ponce M., Abdel Hafez S. K., Raoul F., Craig P. S., and Hamburger J., 2003. Copro-diagnosis of *Echinococcus granulosus* infection in dogs by amplification of a newly identified repeated DNA sequence. *American Journal of Tropical Medicine and Hygiene*, 69(3): pp. 324-330.
- Allan J.C. and Craig P.S., 2006. Coproantigens in taeniasis and echinococcosis. *Parasitology International*. 55: S75 – S80.
- Allan J.C., Craig P.S., García-Noval J., Mencos F., Liu D., Wang Y., Wen H., Zhou P., Stringer R. and Rogan R., 1992. Coproantigen detection for immunodiagnosis of echinococcosis and taeniasis in dogs and humans, *Parasitology* 104: pp. 347–356.
- Anonymous. 2008. Hydatid Disease - Question and Answer Sheet [pdf] Health Challenge Wales.
- Boufana B. (2008) Evaluation of Three PCR Assays for the Identification of the Sheep Strain (Genotype 1) of *Echinococcus granulosus* in Canid Feces and Parasite Tissues. *American Journal of Tropical Medicine and Hygiene*, 78(5): pp. 777–783.
- Brouwer A. and Willson C. 2008. The history of hydatid control in Wales. *Government Veterinary Journal*. pp. 32-35.
- Buishi I., Walters T., Guildea Z., Craig P. S. and Palmer S. 2005. Re-emergence of canine *Echinococcus granulosus* infection, Wales. *Emerging Infectious Diseases*. 11(4): pp.568-571.
- Eckert J., Deplazes P., Craig P.S., Gemmell M.A., Gottstein B., Heath D., Jenkins D.J., Kamiya M., Lightowers M., 2001. Echinococcosis in animals: clinical aspects, diagnosis and treatment. Eckert J., Gemmell M.A., Meslin F.X., Pawlowski Z., eds. *WHO/OIE Manual on Echinococcosis in Humans and Animals: A Public Health Problem of Global Concern*. Paris: Office International des Epizooties, pp. 72–99.
- Lloyd S., Walters T.M.H. & Craig P.S. 1998. Use of sentinel lambs to survey the effect of an education programme on control of transmission of *Echinococcus granulosus* in South Powys, Wales. *Bulletin of the World Health Organization*. 76(5): pp. 469-473.
- Macpherson C.N.L. 1983. An active intermediate host role for man in the life cycle of *Echinococcus granulosus* in Turkana, Kenya. *American Journal of Tropical Medicine and Hygiene*. 32(2): pp. 397-404.
- McManus D.P., [Zhang W.](#), [Li J.](#) and [Bartley P.B.](#), 2003. Echinococcosis. *Lancet*, 362: pp.1295-305.

Moro P. & Schantz P.M., 2009. Echinococcosis: a review. *International Journal of Infectious Diseases*. 13: pp.125-133.

Oswald N., 2007. *The Basics: How Ethanol Precipitation of DNA and RNA Works*. [Online] (Updated 4 December 2007)

Available at: <http://bitesizebio.com/2007/12/04/the-basics-how-ethanol-precipitation-of-dna-and-rna-works/>

[Accessed 02 May 2010].

Palmer S.R., Biffin A.H., Craig P.S. and Walters T.M., 1996. Control of hydatid disease in Wales. *British Medical Journal*. 312: pp. 674-675.

Pawłowski Z.S., Eckert J., Vuitton D.A., Ammann R.W., Kern P., Craig P.S., Dar K.F., De Rosa F., Filice C., Gottstein B., Grimm F., Macpherson C.N.L., Sato N., Todorov T., Uchino J., von Sinner W. and Wen H. Echinococcosis in humans: clinical aspects, diagnosis and treatment. 2001. In: Eckert J., Gemmell M.A., Meslin F.-X., and Pawłowski Z.S. ed. 2001. *WHO/OIE Manual on Echinococcosis in Humans and Animals: a Public Health Problem of Global Concern*. Ch.2.

Walters T.M.H. and Clarkson M.J. 1980. The prevalence of *Echinococcus granulosus* in farm dogs in mid-Wales. *Veterinary Parasitology*. 7: pp. 185-190.

Available at:

<http://wales.gov.uk/docs//drah/publications/081215hydatiddiseaseqaen.pdf>

[Accessed 02 April 2010]

Zhang W., Li J. and McManus D. P. 2003. Concepts in immunology and diagnosis of hydatid disease. *Clinical Microbiological Review*, 16(1): pp.18-36.

Investigating the Emerging Issues that Affect the Online Consumers

Vincent Lui and Mathew Shafaghi, *University of Bolton*

Abstract

In recent years, online shopping has become a popular choice for purchasing goods and services. The British Population Survey (2010) reported that the proportion of the UK population with access to the Internet has reached 76% as of March 2010. With the growth of Internet purchasing, recent studies have found various influences that could affect the online purchasing behaviour of consumers. Consequently, this represents a desirable marketing opportunity for businesses. The understanding of the factors that influence the online shoppers can help marketers to target their marketing activities and to develop appropriate strategies to convert potential customers into actual buyers. The purpose of this study is to develop an understanding of the various influences that affect online shoppers' decision to purchase in the United Kingdom. Semi-structured interviews were used to collect data in order to gain a detailed understanding of the various factors. The study suggests that price, convenience, security and privacy, and delivery time are some of the major concerns for online shoppers. Majority of the consumers also communicated that the ability to view and inspect the item before purchase is the most important aspect that they miss when comparing online shopping to traditional shopping.

The growth of online shopping represents a significant marketing opportunity for businesses and companies that have used other marketing channels in the past. As the Internet population grow exponentially, it is imperative to revise, update, and develop a better understanding of the online shoppers.

1. Introduction

In recent years, online shopping has become a popular choice for purchasing goods and services. British Population Survey (2010) reported that the proportion of the UK population with access to the Internet has reached 76% as of March 2010 and 51% of the adults with access to the Internet have experience shopping online. This represents a significant marketing opportunity for businesses and companies that have used other marketing channels in the past and must now also focus on online business models.

The growth of the Internet users provides a promising future for E-marketers and to benefit from such opportunities, marketers need to further their understanding of online consumer behaviour and develop marketing strategies that would assist them to convert potential customers into actual buyers, while retaining the existing consumers at the same time (Doolin et al. 2005; Vijayasathy & Jones 2000).

This paper is structured to highlight the findings from the review of literature, and is followed by the discussion of methodology used for the study, findings and discussion of the results, and conclusion.

2. Literature Review

Based on an extensive review of literature, various factors and current issues that affect online shoppers' decision to purchase were identified. These were categorised under domain areas of; consumer characteristics, consumer perception, product/service characteristics, merchant characteristics, and provide the basis for and assist in establishing a foundation to progress to the next phase of the study and data collection.

Various authors have discussed their understanding of consumer behaviour and recommended models and frameworks based on their studies including; Doolin et al. (2005), Huang & Oppewal (2006), and Zhou et el. (2007). Whilst the above make a contribution to knowledge in the area of online consumer behaviour, it is difficult to adapt any of the purposed models as being a truly representative of online consumer behaviour. The current literature that focuses on different aspects of online consumer behaviour has been summarised into four domain areas of; consumer characteristics, consumer perception, product/service characteristics, and merchant characteristics as illustrated in Figure 1. For each domain area, their key elements and key findings are identified accompanied by their relevant sources.

	Domain Area	Key Elements	Findings	References
1	Consumer Characteristics	Demographics	Mixed Results	Bhatnagar et al. (2000) Dholakia and Uusitalo (2002) Dillion and Reif (2004)
		Internet Experience	Positive Influence	Donthu and Garcia (1999) Doolin et al. (2005) Kuhlmeier and Knight (2005) Lee and Tan (2003) Li et al. (1999) Liao and Cheung (2001) Mourali et al. (2005) Park and Stoel (2005)
2	Consumer Perception	Perceived Risks	Negative Influence	Culnan (1999) Doolin et al. (2005)
		Convenience	Positive Influence	Li et al. (1999) Limayem et al. (2000) Liu and Wei (2003)
		Social Influences	Positive Influence	Shergill and Chen (2005) Swaminathan et al. (1999) Tan (1999)
3	Product/Service Characteristics	Product Price	Positive Influence	Bakos (1997) Brown et al. (2003)
		Product Information	Positive Influence	Donthu and Garcia (2002) Jayawardhena et al. (2007) Park & Kim (2003)
4	Merchant Characteristics	Website Design	Positive Influence	Hoque and Lohse (1999) Jarvenpaa and Todd (1997)
		Customer Service	Positive Influence	Lohse and Spiller (1998) Park and Kim (2003) Wilson-Jeanselme (2001)

Figure 1. Summary of factors that influence the buyer's behaviour on the Internet

3. Consumer Characteristics

Various studies on demographics have focused on factors that affect the online customer behaviour. Dholakia and Uusitalo (2002) found that younger consumers found more benefits in shopping online than older consumers, while Donthu and Garcia (1999) suggested that older Internet consumers are more likely to buy online than their younger counterparts. On the other hand, Li et al. (1999) argued that there is

no relationship between the age and the consumer's intention to purchase on the Internet. Bhatnagar et al. (2000) who studied age and gender of online consumers reported different results in relation to these characteristics. Meanwhile, Li et al. (1999) indicated that men make more purchases and spend more money online than women. Some studies also found a positive relationship between education and the amount of money spent by consumers (Li et al., 1999; Liao and Cheung 2001). As the growth of Internet population continues and become more diverse, demographics may have a diminishing effect on consumers' behaviour and may be regarded as an element with limited impact on online consumer behaviour.

Another important aspect of consumer characteristics is the Internet experience itself. It is argued that the more experience the user has with the Internet, the more experienced they gain and more trusting they become, which would then lead to a more positive attitude to make a purchase on the Internet (Kuhlmeier and Knight, 2005; Dillion and Reif, 2004; and Doolin et al., 2005). Numerous studies have found that increased shopping experience would reduce the perceived risk (Lee and Tan, 2003; Mourali et al., 2005; Park and Stoel, 2005) and enhance perceived benefits, and thus, induce satisfaction (Doolin et al., 2005). With the exponential growth of Internet population, studies have indicated that Internet shopping would have a positive influence on the consumers as they have more interaction with the Internet.

4. Consumer Perception

Consumers' risk perception is a primary deterrent for growth in the online shopping (Culnan, 1999; Liu and Wei, 2003; Tan, 1999). Product risk, security risk and privacy risk are regarded as the main areas related to consumers' perceived risks (Shergill and Chen, 2005). Much of the literature in this area is indicative of the fact that risks have a negative impact on the consumers' intention to purchase.

The convenience of online shopping allows the customers to save time from having to physically visit stores which in turn would save time and travelling costs. Studies by Swaminathan et al. (1999), Li et al. (1999), and Doolin et al. (2005) confirms that consumers who valued convenience tended to purchase online more often.

Social influences including influences of relatives, friends and colleagues, articles, reviews, and promotions on the website and recommendations from media and family are reported to be important antecedence of shopping intention on the Internet

(Limayem et al., 2000). Their study found that while influence from media and family were significant, friends' influence had limited affect on intentions to purchase.

5. Product/Service Characteristics

Donthu and Garcia (1999) found that price differences between online and offline channels were significant in terms of channel satisfaction.

Many Internet users are attracted to competitive prices that they find online. This is particularly important because innovative pricing strategies are being applied to online goods and services. In recent years, customers are able to take advantage of the lower prices companies offer especially for their Internet consumers. Brown et al. (2003) and Jayawardhena et al. (2007) concluded that price sensitivity is the principal reason behind consumers buying on the Internet.

Product Information is the information provided by the online stores on the products being sold. Some of the product information may include: product attribute, consumer recommendations, evaluation reports, etc (Park & Kim, 2003). Online shoppers cannot physically touch or feel the actual products, at least not at present, so they make their decisions mainly based on information available by the online businesses. It is argued that online stores should give price-related information and product information a precedence to help reduce consumers' search cost (Bakos, 1997). This strategy is currently being used by many companies. Although he suggested that search cost may not be a highly influential factor, the time saved in finding products may still be an important factor.

6. Merchant Characteristics

Consumers expect effective and continuous communication channels across geographical border (Lohse and Spiller, 1998). They expect to communicate with the company and obtain the desired information and advice in a timely manner. These elements are frequently used to determine the store choice behaviour in both online and off-line stores (Jarvenpaa and Todd, 1997). Consumers usually are interested in receiving advice and guidance with product selection, gift services, contact details, and information about shipping costs (Park and Kim, 2003).

When the Website is fast and easy to use, online shopping is thought to be more pleasurable and satisfying for the consumers. Research from various authors including; (Lohse and Spiller, 1998; Hoque and Lohse, 1999; Wilson-Jeanselme, 2001; Park and

Kim, 2003) suggest that the website design have a positive influence in converting potential buyers into actual customers.

The above provides a summary of the elements that are categorized into each of the domains as highlighted in the current literature and illustrated in Figure 1. Much of the literature focuses on various elements of consumer online behaviour. Some of these give priority to the technical element and usability features of the website while others consider psychological and behavioural aspects of the consumer such as demographics, Internet experience, and social influences. As adoption of the Internet continues and demographic of Internet user population diversify, there is a strong necessity to update and extend these studies (Doolin et al., 2005). At present, there is a gap between business practice and scholarly research that focuses on the Internet and its opportunities (Hoffman, 2000; Habul and Trifts, 2000). Some recent journal publications have hence tried to address this but there are still a lot to be done in order to close this gap in trying to understand the Internet consumer (Shim et al., 2001).

7. Methodology

Following the literature review, semi-structured interviews were conducted to gain a comprehensive understanding of the consumers' view on Internet shopping. Clark et al. (1998) and Gwinner et al. (1998) suggest that exploratory research can add new dimensions and provide a deeper understand to the issues under study. Semi-structured interviews were selected to carry out this exploratory research because of its adaptable approach to collect data. The interviewers have more freedom in deciding on the sequence of the questions and extra attention could be given to different topics (Robson, 2003) and new questions to be brought up. The aim was to develop an understanding the consumers' thoughts, views and experiences associated with online shopping. According to Flick (1998) and Neuman (1997), semi-structured interviews can help in exploratory research or in generating new ideas for hypotheses. The semi-structured interviews were conducted in two stages:

A sample of 41 participants was targeted for obtaining information about Internet shopping.

A further sample of 28 online shoppers was invited to comment on the findings of the 1st stage.

The questions raised in the interviews were mainly open-ended and designed to allow the interviewees' to express in detail their thoughts and experience on online shopping.

The questions were carefully thought out to explore the themes of the research. The interview process was semi-structured and thus there was flexibility to allow the interviewees to introduce additional opinion, feeling, explanation and clarification regarding the topic.

The open-ended questions designed to elicit detailed information from the participants were based on the key themes of:

- consumer characteristics
- consumer perception
- product/service characteristics
- merchant characteristics

The development of these themes was drawn from the thorough review of literature as discussed in the Literature Review section. They served as a preliminary foundation for extracting information from the interviewees.

Following the above, interviews were conducted with a sample of 28 participants and focused on further exploitation of the issues associated with online shopping and discussions on the findings of the previous set of interviews. Similarly, the interviews were structured in an open manner with a goal to draw out any additional expected and unexpected findings from the participants.

8. Results and Discussion

The sample consisted of 41 participants, a total of ten were aged between 16-25; sixteen between 26-35; and fifteen between 36-55 participated. Nineteen of them were males and twenty-two were female. It included participants who have shopped online and also those who have never shopped online to understanding the issues that influence the online shoppers. The majority of the interviewees had experience purchasing online. They were encouraged to share their thoughts on both the positive and negative aspects of online shopping. For those that have never shopped online, more explorative questions concentrated on the reasons why they have not.

The findings are in line with previous studies, however, as a result of the growth and experience and sophistication of online shoppers there are new and emerging factors that are considered important to the same.

Generally, price was mentioned by the majority of the participants concurring that cheaper prices can usually be found online. This was further supported by the availability of discount vouchers and promotions. The participants also found that

comparison facilities and product reviews are very useful and become a big influence on their decision to purchase. Some also stated that there are “more to choose from” when referring to the range of items available from online shopping.

“Convenience” was identified by over 75% of the participants as one of the reasons for shopping online, as it can be done anytime of the day and from anywhere. Some mention the “lack of time” to travel to high-street stores to purchase because of their work while others mention the “inconveniences of travelling” without their own transportation and inability to travel due to physical disabilities. On the other hand, some participants commented that they dislike having to “wait” or “stay at home” for the item to arrive.

Over 60% of the participants suggested that they are more likely to purchase from online retailers that are perceived to be “reliable”, “well-known”, “responsible” and “honest”. They also believed they would be more willing to purchase again from the same online retailer if they were satisfied with a previous purchase experience. 78% of the respondents commented that if they have a positive shopping experience with the brick-and-mortar (high street) store before, they would be willing to purchase from the retailer’s online shop as well. Interestingly they added that they can usually find “more products” being sold from the online equivalent while others mention it’s sometimes even “cheaper”.

“Safety of online transaction” was frequently raised by over 80% of the respondents. Online shoppers are worried about their “security” and “privacy” when shopping online. Some respondents stated they have decided not to follow through with a transaction because the website did not appear to be “secure”. The interviewees expressed dislike to receive “spam”; referring to the advertisement via emails that was sent to their email addresses without their prior consent. However, they suggested that they would be more receptive to promotional emails from online retailers if they are given “vouchers”, “discounts” and “special offers” as incentives to purchase. “Security” and “privacy” were also reported as a major area of concern by the participants that have never shopped online or had little past experience of shopping online. They also mention they would rather “touch and feel” the product when they wish to purchase an item.

The participants expressed the ease to shop frequently online, however, when faced with the request for the creation of account by the online store; a minority of interviewees did not feel comfortable and were reluctant to go ahead. The results

suggest that whilst some online shoppers prefer to check out quickly by entering as little information as possible about themselves online, others would rather enter all their information by saving their details in an account so that it will be more convenient the next time they wish to purchase from the same retailer.

Not surprisingly, many of the participants indicated their high expectations of the “website design”, and “usability” provided by the online stores. These were reported to include; poor design and functionality, navigation and finding products/information, often leading to a non-purchase decision. Some respondents also considered “reviews” and “price –comparison” facilities useful in assisting their purchasing decision.

Over 60% of the participants expressed that upon a positive experience, they would be willing to spread the word and recommend the online stores to friends and family. Some participants also mentioned that they use shopping discussion forums to identify “good deals”. Also, recommendations from family and friends are often important to them. The participants believed that the websites should be easy to use, have search function, facilities for easier browsing, detailed product description, and expect the website to be fast and attractive. They also expect to have good customer services that respond quickly and offer product tracking facilities after purchase. Additionally, the interviewees reveal that they are more likely to purchase if the online retailer offer free shipping and returns, or cheap shipping.

9. Conclusion

Through the review of literature and semi-structured interviews, the findings suggest common themes can be summarised as positive factors, negative factors and factors that can increase customer satisfaction.

The common themes that can be associated with the positive factors affecting the online consumers include cheaper prices, convenience, ease of use, easy to research on a product, and the ability to comparison shop quickly. In general, price and convenience were mentioned most frequently during the semi-structured interviews.

The common themes that can be associated with negative factors affecting the online consumers include the security of the online transaction, privacy of the personal information, delay of shipment, and inability to track the item’s arrival. In general, security and privacy associated with the safety of online transactions were mentioned most frequently during the semi-structured interviews.

The common themes that can be associated with increasing the satisfaction online consumers include useful website functions, website loading time, personalisation, friendly and prompt online and offline customer services, and availability of incentives including; discount vouchers, promotions and reduction of delivery time.

Participants from the semi-structured interviews also revealed their dissatisfaction with online shopping on a number of occasions but felt the positive experiences in previous successful transactions outweighs the negatives. What they seem to miss most compared to traditional shopping is that they cannot see and inspect the item before purchase. The influence of family, media, and friends is also perceived as important.

This paper has provided a holistic view of the research to date towards an integrative framework to capture the essence of factors that influence the online shoppers. This paper focuses on the exploratory phase of the research and describes the key issues that have emerged through literature review and semi-structured interviews which provided a foundation of factors that influence the online shoppers. These findings will contribute to a better understanding of the current issues and upon further evidence and data collection, will assist in developing the integrative framework of the factors that influence the online shoppers.

10. Future Work

It is intended to extend the findings from this paper to be representative of the UK online shoppers. By working qualitatively and quantitatively, the results from the qualitative stage can be linked to a statistically representative sample with the inclusion of quantitative data (Brannen, 2005; Onwuegbuzie and Leech, 2005).

The next stage of the study is to strive to achieve generation of data to a large number of the population so it can better represent the views of the wider population.

11. References

- Bakos, J. (1997) "A Strategic Analysis of Electronic Marketplace," *MIS Quarterly*, Vol. 15:295-310.
- Bhatnagar, A., Misra, S., and Rao, H. (2000) "On Risk, Convenience, and Internet Shopping Behavior," *Communications of the ACM*, Vol 43, No. 11:98-105.

- Brannen, J. (2005) "Mixing Methods: The Entry of Qualitative and Quantitative Approaches into the Research Process," *International Journal of Research Methodology*, Vol. 8, No. 3:173-184.
- Brown, M., Pope, N., and Voges, K (2003) "Buying or Browsing? An exploration of shopping orientations and online purchase intention," *European Journal of Marketing*, Vol. 37, No. 10/11:1666-1684.
- Clark, M.R., Michael, W.E. and Wood, R.C. (1998) "Researching and Writing Dissertations in Hospitality and Tourism," London: International Thomson Business.
- Culnan, M. and Armstrong, P. (1999) "Information Privacy Concerns, Procedural Fairness and Impersonal Trust: An Empirical Investigation," *Organization Science*, Vol. 10, No. 1:104-115.
- Dholakia, R. and Uusitalo, O. (2002) "Switching to Electronic Stores: Consumer Characteristics and the Perception of Shopping Benefits," *International Journal of Retail and Distribution Management*, Vol. 30, No. 10:459-469.
- Dillion, T. and Reif, H. (2004) "Factors Influencing Consumers' E-Commerce Commodity Purchases," *Information Technology, Learning, and Performance Journal*, Vol. 22, No. 2:1-12.
- Donthu, N. and Garcia, A. (1999) "The Internet Shopper," *Journal of Advertising Research*, Vol. 39, No. 3:52-58.
- Doolin, B., Dillon, S., Thompson, F., and Corner, J. (2005) "Perceived Risk, the Internet Shopping Experience and Online Purchasing Behaviour: A New Zealand Perspective," *Journal of Global Information Management*, Vol. 13, No. 2:66-89.
- Flick, U. (1998) "An Introduction to Qualitative Research," London: SAGE Publications.
- Gwinner, K.P., Gremier, D.D. and Bitner, M.J. (1998) "Relational Benefits in Services Industries: The Customer's Perspective," *Journal of the Academy of Marketing Science*, Vol. 26, No. 2:101-114.
- Habul, G. and Trifts, V. (2000) "Consumer decision making in online shopping environments: the effects of interactive decision aids," *Journal of Marketing Science* Vol. 19, No. 1:4-21.
- Hoffman, D. (2000) "The Revolution Will Not Be Televised: Introduction to the Special Issue on Marketing Science and the Internet," *Journal of Marketing Science*, Vol. 19, No. 1:1-3.

- Hoque, A. and Loshse, G. (1999) "An Information Search Cost Perspective for Design Interfaces for Electronic Commerce," *Journal of Marketing Research*, Vol. 36, No. 3:387-94.
- Huang, Y. and Oppewal, H. (2006) "Why Consumer Hesitate to Shop Online: An Experimental Choice Analysis of Grocery Shopping and the Role of Delivery Fees," *International Journal of Retail & Distribution Management*, Vol. 34, No. 4/5:334-354.
- Jarvenpaa, S. and Todd, P. (1997) "Consumer Reactions to Electronic Shopping on the World Wide Web," *International Journal of Electronic Commerce*, Vol. 1, No. 2:59-88.
- Jayawardhena, C., Wright, L., and Dennis, C. (2007) "Consumers Online: Intentions, Orientations and Segmentation," *International Journal of Retail & Distribution Management*, Vol. 35, No. 6:515-526.
- Kuhlmeier, D. and Knight, G. (2005) "Antecedents to Internet-Based Purchasing: a Multinational Study," *International Marketing Review*, Vol. 22, No. 4:460-473.
- Lee, K. and Tan, S. (2003) "E-retailing Versus Physical Retailing: a Theoretical Model and Empirical Test of Consumer Choice," *Journal of Business Research*, Vol. 56, No. 11:877-85.
- Li, H., Kuo, C., and Russell, M. (1999) "The Impact of Perceived Channel Utilities, Shopping Orientations, and Demographics on the Consumer's Online Buying Behaviour," *Journal of Computer Mediated Communication*, Vol. 5, No. 2.
- Liao, Z. and Cheung, M.T. (2001) "Internet-Based E-Shopping and Consumer Attitudes an Empirical Study," *Information & Management* Vol. 38, No 5: 299-306.
- Limayem, M., Khalifa, M., and Frini, A. (2000) "What Makes Consumers Buy From Internet? A Longitudinal Study of Online Shopping," *IEEE Transactions on Systems, Man, and Cybernetics-Part A: Systems and Humans*, Vol. 30, No. 4:421-432.
- Liu, X. and Wei, K. (2003) "An Empirical Study of Product Differences in Consumers' E-commerce Adoption Behavior," *Journal of Electronic Commerce Research and Applications*, Vol. 2, No. 3:229-239.
- Lohse, G. and Spiller, P. (1998) "Electronic Shopping," *Communications of ACM*, Vol. 41, No. 7:81-89.
- Mourali, M., Laroche, M., and Pons, F. (2005) "Antecedents of Consumer Relative Preference for Interpersonal Information Sources in Pre-Purchase Search," *Journal of Consumer Behavior*, Vol. 4, No. 5:307-318.
- Neuman, W.L. (1997) "Social Research Methods - Qualitative and Quantitative Approaches," Boston: Allyn and Bacon.

- Onwuegbuzie, A.J. and Leech, N.L. (2005) "On Becoming a Pragmatic Researcher: The Importance of Combining Quantitative and Qualitative Research Methodologies," *International Journal of Social Research Methodology*, Vol. 8, No. 5:375-387.
- Park, C. and Kim, Y. (2003) "Identifying Key Factors Affecting Consumer Purchase Behaviour in an Online Shopping Context," *International Journal of Retail & Distribution Management*, Vol. 31, No. 1:16-46.
- Park, J. and Stoel, L. (2005) "Effect of Brand Familiarity, Experience and Information on Online Apparel Purchase," *International Journal of Retail & Distribution Management*, Vol. 33, No. 2:148-160.
- Robson, C. (2003) "Real World Research: A Resource for Social Scientists and Practitioner-Researchers," Oxford: Blackwell Publishers Ltd.
- Shergill, G. and Chen, Z. (2005) "Web-Based Shopping: Consumers' Attitudes Towards Online Shopping in New Zealand," *Journal of Electronic Commerce Research*, Vol. 6, No. 2:78-93.
- Shim, S., Eastlick, M., Lotz, S., and Warrington, P. (2001) "An Online Pre-Purchase Intentions Model: the Role of Intention to Search," *Journal of Retailing*, Vol. 77, No. 3:397-416.
- Swaminathan, V., Lepkowska-White, E., and Rao, B. (1999) "Browsers or Buyers in Cyberspace? An Investigation of Factors Influencing Electronic Exchange," *Journal of Computer Mediated Communication*, Vol. 5, No. 2:1-23.
- Tan, S. (1999) "Strategies for Reducing Consumers' Risk Aversion in Internet Shopping," *Journal of Consumer Marketing*, Vol. 16, No. 2:163-180.
- British Population Survey (2010), [Online], Available: <http://www.thebps.co.uk/> [August 2010].
- Vijayarathy, L. and Jones, J. (2000) "Print and Internet Catalogue Shopping: Assessing Attitudes and Intentions," *Journal of Internet Research*, Vol. 10, No. 3:191-202.
- Wilson-Jeanselme, M. (2001) "Grocery Retailing on the Internet: the Leaky Bucket Theory," *European Retail Digest*, Vol. 30:9-12.
- Zhou, L., Dai, L., and Zhang D. (2007) "Online Shopping Acceptance Model – A Critical Survey of Consumer Factors in Online Shopping," *Journal of Electronic Commerce Research*, Vol. 8, No. 1:41-62.

Bloodless Minutes of Global-local Fear: Identity in the Novel *Senza sangue*, the Film *Vier Minuten* and the Music Video *The Fear*

Mattia Marino, *University of Salford*

Abstract

In the early twenty-first century, the encounter between the west and the rest entails a tension between global and local practices where collective identity and memory are in a process of renegotiation. It is possible to discuss part of this complex picture in a textual analysis which accounts for a wide variety of factors involved in global-local identities by shifting attention from ethnicity and the clash of civilisations to differences of age, health, and class within western communities. Across the boundaries of European cultures and the communication forms of literature, cinema, and media, which are central in the early twenty-first century, a suitable selection of texts comprises the novel *Senza sangue* (Without Blood) (Baricco, 2002), the film *Vier Minuten* (Four Minutes) (Kraus, 2006), and the music video for the pop-song *The Fear* (Allen, 2009). As their narrative representations combine gender identity with age, citizenship, and class, their intertextual relationships offer a wide-ranging discussion about the changes taking place in global-local identities. This issue need be addressed by taking into account the fact that the violence represented across these texts is connected with cultural memory, which defines identity in opposition to otherness. The definition of identity sanctions the violent exclusion of the Other, in terms of gender, age, citizenship, class, and related categories. In a global-local context, the novel, the film, and the music video converge in the exposure of identity as conformation to norms, which is overcome in representations of hybridity.

Global-local Identities

In the early twenty-first century, the encounter between the west and the rest entails a tension between global and local practices where collective identity and memory are in a process of renegotiation. It is possible to discuss part of this complex picture in a textual analysis which accounts for a wide variety of factors involved in global-local identities by shifting attention from ethnicity and the clash of civilisations to differences of age, health, and class within western communities. Across the boundaries of European cultures and the communication forms of literature, cinema,

and media, which are central in the early twenty-first century, a suitable selection of texts comprises the novel *Senza sangue* (Without Blood) (Baricco, 2002), the film *Vier Minuten* (Four Minutes) (Kraus, 2006), and the music video for the pop-song *The Fear* (Allen, 2009). As their narrative representations combine gender identity with age, citizenship (as subjection to state authority, specifically in prison), and class, their intertextual relationships offer a wide-ranging discussion about the changes taking place in global-local identities. This issue need be addressed by taking into account the fact that the violence represented across these texts is connected with cultural memory, which defines identity in opposition to otherness. The definition of identity goes hand in hand with the violent exclusion of the Other, in terms of gender, age, citizenship, class, and related categories. In a global-local context, the novel, the film, and the music video converge in the exposure of identity as conformation to norms, which is overcome in representations of hybridity, understood not in an ethnic sense, but in more nuanced socio-cultural connections.

What are hybrids? The debate is urgent in the ever more interconnected societies of the early twenty-first century:

. . . ils se comptent par milliers, par millions, et leurs nombre ne cessera de croître. « Frontaliers » de naissance, ou par les hasards de leur trajectoire, ou encore par volonté délibérée, ils peuvent peser sur les événements et faire pencher la balance dans un sens ou dans l'autre. Ceux parmi eux qui pourront assumer pleinement leur diversité serviront de « relais » entre les diverses communautés, les diverses cultures, et joueront en quelque sorte le rôle de « ciment » au sein des sociétés où ils vivent. En revanche, ceux qui ne pourront pas assumer leur propre diversité se retrouveront parfois parmi les plus virulents des tueurs identitaires, s'acharnant sur ceux qui représentent cette part d'eux-mêmes qu'ils voudraient faire oublier. Une « haine de soi » dont on a vu de nombreux exemples à travers l'Histoire... (Maalouf, 1998: 46).⁴

“Border-dwellers”, or hybrids, are crosses of different entities, e.g., a mule is a cross between a horse and a donkey. Yet, actually, all entities are hybrids, in so far as everything is part of many other different things: a table is part of a room, a house, and

⁴they are thousands and millions, their number will not cease to grow. “Border-dwellers” by birth, chance, or deliberate choice, they can weigh on events and make the balance hang on one or the other side. Those amongst them who will be capable of fully taking on their otherness will soften the relationships between different communities and languages, by strengthening the connections within the societies where they live. In contrast, those who will not be capable of taking on their own otherness might end up as some of the most restless identity-thirsty murderers, hitting those who represent that part of themselves which they would like to erase from memory. A form of “self-hatred” which has seen many an example across History.

the realm of inanimate things; a rose is part of a garden, a bush, and the realm of living organisms; a human being is part of many different groups simultaneously, despite the boundaries separating these different groups. As soon as interests conflict with each other and it is necessary to take sides, single identities distinguished from each other by essentialist boundaries are affirmed by collective and individual memory, doing violence to all other features of one's distinctive individuality, as well as to the others from the opposite side of the relevant boundaries. In the early twenty-first century, global and local conflicts related to those hinted at in the passage above revolve around questions of identity. The Islamist attacks in New York and other western cities, as well as western countries' military interventions in Islamic countries, ensue from the essentialist distinction between modern west and the rest. The awareness of hybridity, that is, of every entity's multiple memberships, often also across the boundary between the west and the rest, is crucial in discussions on global-local hybridity. Within western communities, such social differences as gender, age, health, and class are crossed in hybrid combinations of privilege and discrimination where the main characters construct their identity and memory critically and creatively in *Senza sangue*, *Vier Minuten*, and *The Fear*.

Essentialist boundaries between different forms of identity are considered with suspicion precisely due to the impossibility for anything like single, essential or pure identities to exist at all:

. . . een proces van onttovering . . . komt tot uiting in het verander(en)de karakter van culturele gemeenschappen: deelhebben aan een bepaalde cultuur is steeds minder eenduidig geworden, omdat de culturele kern van een gemeenschap alleen maar zuiver kan blijven bij volstrekt isolement. Van een dergelijk isolement kan in de hedendaagse fase van globalisering helemaal geen sprake meer zijn, maar de onttovering is in feite al begonnen aan het begin van het moderniseringsproces: modernisering en menging van gemeenschappen zijn altijd hand in hand gegaan. (Koenis, 2008: 272-73)⁵

⁵ a process of disenchantment comes to expression in the changed and changing character of cultural communities: taking part in a specific culture has become ever less clear, as the cultural core of a community can remain pure only in perfect isolation. In the current phase of globalisation such an isolation is not possible any longer; in fact, disenchantment began already at the start of modernisation, which has always gone hand in hand with a blending of communities.

Paradoxically, modernity contributes to the hybridisation involved in existence, as it generates increased contact between groups separated by essentialist boundaries, while also creating an essentialist separation from groups where values different from modern ones are cherished. On the one hand, global-local societies are marked by disenchantment with respect to essentialist boundaries. On the other hand, social distinctions always play an important part, as represented in the three texts in discussion, which share the noteworthy feature of presenting doubly disadvantaged characters, that is, not only as women, but also as elderly, detained, and low class.

Global-local hybridity, that is, the set of crosses between privileged and discriminated identities in the highly heterogeneous societies of the early twenty-first century, involves not only conflicts, but also possibilities:

Nella società della comunicazione generalizzata e della pluralità delle culture, l'incontro con altri mondi e forme di vita . . . significa fare esperienza della libertà come oscillazione continua tra appartenenza e spaesamento. È una libertà problematica, . . . facciamo fatica a concepire questa oscillazione come libertà: la nostalgia degli orizzonti chiusi, minacciosi e rassicuranti insieme, è sempre ancora radicata in noi, come individui e come società. (Vattimo, 1989/2000: 19-20)⁶

The tension between the nostalgia for less diverse, or complex, societies, despite the disenchantment with essentialist boundaries, and the enjoyment of dangling between participating to and retreating from the diversity of global-local societies is characteristic of global-local hybrids. A textual analysis of the relationships between the novel, the film, and the music video displays the empowering role of hybridity in early-twenty-first-century western social groups, as represented across different art forms.

Textual analysis is a semiotic method, as it examines signs (Eco, 1976: 7), precisely not for what, but for how, that is, the ways in which they mean (Sturrock, 1986: 22). Language is only one of the infinite and all-pervasive systems of signs in use (Barthes, 1967: 9), and presents a level of abstraction which makes it particularly suitable in the philosophical discussion of being (Saussure, 1983: 16). Identity is socially constructed

⁶ In mass-media-based and multicultural societies, the cross between different worlds and lifestyles . . . means an experience of freedom as a ceaseless dangling (or swinging, oscillation) between belonging and estrangement. It is a problematic freedom, . . . it is hard to conceive this dangling as freedom: nostalgia leads us back to enclosed, both threatening and reassuring horizons, both on the individual and the social level.

in and through narratives which articulate meaningful memory (Ricoeur, 1984: 52). Memory is a dynamic process where antecedent utterances and meanings are renegotiated (Rigney, 2006). Using language, or, for that matter, any other semiotic system, involves a dialectics between the available means to create meaning (Lévi-Strauss, 1974: 29). In this respect, texts' cultural contexts play a significant role (Lotman, 1990: 124-125), which hints at the desirability of an interdisciplinary socio-historic-philosophical approach.

In the socio-historical context of the early twenty-first century, global-local hybridity involves a renegotiation of identity and memory beyond the historicist ideology of progress, with its dream of techno-scientific control (Claeys, 2005: 273). While techno-scientific essentialism posits rationality as the absolute essence of being, a critical ontology of hybrid history poses the force of being as relative to the different perspectives, or philosophical perspectivism (Nietzsche, 1887), of its phenomenological forms, which constitute a structure of consensual meaning from which each of them differs (Foucault, 1969) in the philosophical post-structuralism of its particular intersections, or sociological intersectionality (Crenshaw, 2005). As being is relative to perspective, social rituals provide a space of consent where different perspectives can interact in an orderly structure of conventions, which define identity and memory in terms of language, belief, class, sex, gender, sexuality, ethnicity, citizenship, health, and age. Each particular perspective is characterised by unique intersections of these socially constructed categories of identity and memory. Global-local identities are hybrids of social categories, with the critical and creative power to be different from the forms sanctioned in these categories. *Senza sangue*, *Vier Minuten*, and *The Fear* represent narratives of women who overcome specific gender norms of conventionally defined worthy and legitimate womanhood in their hybrid crosses with older age, detention in prison, and low class. Their intertextual relations revolve around a representation of identity which transcends essentialist norms of femininity and hints at the power of redefining one's identity in ever different crosses of behavioural patterns from different categories of identity.

Memory Beyond Violence

In Bariccos's *Senza sangue*, the protagonist's many names and the violent loss of her family represent the transiency and the horror of being, in contrast to the stable norms through which cultural memory defines identity, in general, and femininity, in

particular. The force attracting her is that of her unknown saviour, whom she meets in the transient scenery of typical non-places, namely a bar and a motel. Ontological doubt is conveyed through the tales about her supposed insanity, and existential relativity to perspective is displayed in the dialectics between her saviour's obstinate memory and her own fatalist forgetfulness and sublimation. To start with, transiency is represented by what can be defined as the protagonist's polyonymy, that is, her having many different names, referring to the changes she undergoes. The suggestion is that she cannot be crystallised and fixed in one unchanging essence, as she is actually a hybrid characterised by openness to different possible forms. The other side of the coin of transiency is the horror evoked by the violent loss of her family in a vendetta action, while a child. She learns from an early age how everything inexorably passes and returns in irredeemably different forms, following the force of transience.

Her story is actually the story of her fatalistic nostalgia (64) to her unknown saviour, who is one of the murderers of her family who decided to let her survive. She is fatally drawn to him by the force of her own transient existence. After many years, when they are old, the places where she meets up with him are the transient sceneries of a motel and a bar, where everyone is merely passing temporarily. Against this background of impermanence, the tales surrounding her supposed insanity and potential search for revenge are revealed as mere possibilities, while nothing is certain. Her hybrid identity, irreducible to any one essence, is evoked when she appears as a "vecchia donna matta ... bambina" (mad old woman child) (89), condensing her weakness in society due to her old age, female sex, dubious mental health, and refusal to move far away from her dramatic situation when she was only a child. Actually, she makes virtue of necessity, as her story suggests. Instead of suffering social injustice as a victim, disadvantaged both as a woman and as elderly, she takes on her hybridity and deploys it to make sense of existence and to simply be in a meaningful way.

Her perspective of forgetfulness and his perspective of memory encounter in a fatalistic revaluation of existence. In fact, while being irresistibly drawn to her past, she gives up all possible vengeful memories to fatalistically embrace her family's murderer and her own saviour, with whom she spends a night. Conversely, he is convinced that at any moment she might kill him to quench some savage thirst for revenge, as he cannot forget the horror of his own violent vendetta, which he bitterly regrets. Only she has the relativist force to revalue that horror and find it again in him

with the fatalist critical creativity represented by her foetal position. Both during the vendetta as a child and while leaning against her murderer/saviour's shoulders as an old lady, she gets "rannicchiata" (cuddled up) to "addormentarsi" (fall asleep) and "sognare" (dream) (13), as if in a "conchiglia tutto" (shell-whole) (15-6) characterised by simple "esattezza" (exactitude) (19), unaware of "memoria ... giustizia ... vendetta" (memory, justice, revenge) (68-88).

Tellingly, one of the stories around her suggests that she had "mai parlato" (never spoken) (71), hinting at her fatalist forgetfulness of the linguistic and cultural conventions aimed at defending oneself from impermanence, as she disposes on sufficient critically creative imagination to engage in the relativist embracement of transiency simply by sleeping and dreaming. After all, the cause of "male" (evil) (82) amounts to the conflict between different stories from different perspectives, each aspiring to the crowning of the absolutist illusion of a "mondo migliore" (better world) (85). The existential possibility of "pace" (peace) (92) is offered in that primordial position of sleeping and dreaming relativist stories, without attempting to force them over alternative stories; without blood. Her assertion of her identity in a cross of female and elderly symbolical performative acts hints at her power to overcome her socially constructed weakness as a survivor. The central metaphor of sleeping as a baby suggests the disarming force of her refusal to conform to the norms defining her identity.

Hybrid Minutes

In contrast to the illusion of stability inherent in essentialist definitions of identity, hybrid identities embrace existence in its chaotic changes. Existence looks like a frantic movement which ceases only in its final consumption. This is condensed in the image of a helpless moth violently battering with his wings on the cold surface of a piano till he dies, which is a mesmerising scene of Chris Kraus' 2006 film *Vier Minuten*. This scene also condenses the deeper meaning of the film's story. Since the Nazi time, Gertrud Krüger has devoted all her life to music and ends up as the piano teacher of a women's prison, where 20-year old Jenny von Loeben is kept. Both women bear the indelible traces of trauma, as the old teacher's only love was a communist woman tortured and killed by the Nazis, and the young pupil used to be sexually abused by her father and expresses all her inner rage in frequent acts of extreme violence. Frau Krüger is overwhelmed by Jenny's musical talent and offers

her help to make her fulfil it, preparing her for a prestigious contest. Once on the stage, instead of playing the long-studied Schumann piece, Jenny takes her chance to finally express her identity without restraints in a virtuoso four-minute performance with elements of jazz and experimentation pushed to the use of her whole body hitting the piano as percussions, with an extraordinary energy. The audience is enthusiastic and even Frau Krüger puts aside her contempt for alternative music to toast to Jenny's free expression, as the young pianist makes her public a curtsy and is handcuffed again. Like a moth inexorably battering his wings for the duration of his existence, Jenny enjoys to the full her opportunity while bearing her life in captivity. Although her disadvantage is twofold, that is, as a woman and as a state disciplined citizen, she embraces her seemingly disadvantageous hybridity and takes advantage of it.

Like a moth restlessly battering his wings against the corners to which he flutters without pause in the prison of a window pane, Jenny struggles to come to terms with her trauma in the prison where she is detained. Similarly, Frau Krüger faces every moment the painful memories of her own trauma in the prison of existence. With her strict discipline as a classical pianist, she disdains her pupil's "nigger music" full of rage and free improvisation. Nevertheless, she realises that Jenny has got a "gift" and, along with it, the "mission" (or task, Aufgabe) to fulfil her potential as a musician. In her turn, Jenny realises that the old lady is the key for her to express her potentiality, her power within the constraints of prison. Therefore, she accepts to conform herself to the teacher's severe discipline and pass the selection for the contest, only to finally express her individuality in her unexpectedly free performance, after which she can be handcuffed again and continue living in prison with a new awareness of her existence. On her part, Frau Krüger expresses herself, too, by crowning her career with her pupil's success in the theatre, after which she can bear her own existential prison of traumatic memories with a new self-awareness. Teacher and pupil ultimately assert themselves within the constraints of their trauma-marked existence, like a moth enjoying to the full his possibilities, albeit meagre, of pleasure.

In *Vier Minuten*, Jenny fatalistically embraces the eternal recurrence of the constraints imposed on her individual freedom. Not for a moment does she indulge in the sweet hope of going out of prison. With this hyperbolic amor fati, she invests all her energy in her personal power: music. Jenny overcomes her peers in prison by

learning from the teacher the discipline to reach the best which she can attain, namely passing the selection for the contest. Her fear of her peers' aggression is an expression of her will to power, as it endows her with the emotional weapon to be ready for any attack that might jeopardise her ability to continue playing. In fact, when her jail-mate sets her arm on fire in the night she is well-prepared to take action, eventually hitting her pyromaniac jail-mate almost to death.

Frau Krüger's rationality is a manifestation of her will to power, as well. Her demonic plan to get Jenny out of jail for the final performance, even though she should stay in prison due to an unjust punishment, is studied to the most minute detail and ultimately serves the teacher's will to crown her career with her pupil's success in the theatre at the prestigious contest. Like the detainee, the teacher has to overcome the constraints imposed on her individual freedom by the discourse of collective memory in and through which her identity is socially defined. The narrative of the detained pianist offers a representation of a woman who overcomes the normative constraints of her gender by embracing her condition as a detainee, whose rebellion against authority is sublimated in the final musical performance.

Identity and Fear

In the music video of the pop-song *The Fear*, Lily Allen plays the role of a low-class teenage girl who escapes her socially determined duty as a poor raiser of children by engaging in a hilarious ascent to fame, where she uses her gendered body as a tool for success. Her body is seemingly defenceless both as a woman and as a poor; actually, she makes the best of this apparently disadvantageous hybrid identity. The song and the video offer a playful caricature of consumerist societies, where disenchantment with traditional values is ironically camouflaged as innocent fear, associated with uncertainty. Fame is subtly connected to prostitution, as the lyrics stress the girl's willingness to show her nudity in order to become a celebrity. Ultimately, the visual, musical, and linguistic text lends itself to an interpretation of the climate of fear and uncertainty pervading heterogeneous societies as the existential chance to succeed while pretending to be subservient to the sexist system.

The initial situation is visualised in the images of the girl living in miserable conditions in a caravan. Her dreams of economic success exclude the traditional values attached

to qualities and emotions (“I want to be rich and I want to be famous / I don’t care about clever, I don’t care about funny”). The simplicity of scenery and lyrics corresponds to very simple melodies and arrangements. The singer manages to mimic with her voice a low and intimate tone, which suggests complicity and enhances the comic effect of the whole text. Lily is in a colourful attire and looks seriously into the camera, sometimes smiling maliciously as in a parody of the stereotypes surrounding adolescents in consumerist contexts.

The refrain exposes the central feeling of fear, which involves uncertainty as to what to do and what to believe in. The second sentence stresses the inability to feel genuine emotions: “I don’t know how I’m meant to feel anymore”. The iteration of the adverb anymore conveys the idea of irrevocable change, in a definitive shift away from a stable past. This rhetorical choices are related to concerns about the deleterious impact of consumerism and modernity upon teenagers, in particular. The clarity of vision characterising the teenager’s words and acts which constitute the context of the refrain reveals that her fear is only ironically dissimulated, while she knows very well what to do in the sexist system where she looks like an innocent victim.

The underlying irony is evident from the contrast between her supposed fear and the confidence with which she receives the attention and services of her male servants who dance around her in the fabulous manor house where she ends up thanks to her willingness to sell her body to the media. Exactly after singing the refrain for the first time, she asserts that “life’s all about film stars and less about mothers”, and that she herself is “a weapon of massive consumption”. The second time that she sings the refrain, her servants are masked as boxes with ribbons on a chessboard where she is the indisputable queen of the game, as the chessboard and the men dressed as birthday presents suggest that in consumerism everything is play.

Even terrorism and war are games, as Lily proclaims: “Forget about guns and forget ammunitions / ‘coz I’m killing them all on my own little mission (...) and everything’s cool as long as I’m getting thinner”. In delirious metaphors, teenage anorexia is associated with weapons of war, and the overall sense of fakeness and illusion triumphs in the profusion of coloured balloons when she sings the refrain for the last time. The hyperbolic extravaganza of *The Fear* hinges on the power of embracing the norms regulating one’s socially constructed identity in order to subvert them from a

critical and creative position where a sexualised low-class woman becomes the master of the consumerist game. The cross of fake fear and unrestrained confidence is an irresistible hybrid which constitutes an ironic critique to the norms of identity in the early twenty-first century.

Beyond the Fear of Hybridity

In the novel *Senza sangue*, the film *Vier Minuten*, and the music video *The Fear*, the narratives of the elderly, the detained, and the class climber overcome essentialist norms of female identity in a hybrid blending with older age, disciplined citizenship, and mobile class, respectively. The elderly woman refuses to define her identity in a definitive way, as her existential choice is to fatalistically embrace events without trying to force them, but rather by making sense of them, also loving a man whom she had reason to hate. The detained pianist channels the discipline to which she is subject into a performance which transcends the norms to which she is expected to conform. The rising teenager pretends to become a slave to consumerism, only to finally be served by it. The three texts overcome the fear of instability inherent in essentially defined identity through representations of hybrids who love the precariousness of their own condition, without conforming to stable conventions.

Across the boundaries separating literature from cinema and media, these three works present interesting points in common which bear witness to the possibilities available in early-twenty-first-century global-local contexts. Their common concern with doubly disadvantaged women leads to parallel reflections on the power of a critical and creative embracing of one's hybridity, beyond the ideal of a stable identity in function of the fear of instability. The very different styles of literary minimalism, cinematic theatricality, and ironic pop extravaganza meet at a confluence of identity overcoming the sameness of one-sided conformation.

References

- Baricco, A., 2002. *Senza sangue*. Milan: Rizzoli.
- Barthes, R., 1967. *Elements of Semiology*. London: Jonathan Cape.
- Claeys, G., 2005. *Encyclopaedia of Nineteenth-Century Thought*. New York: Routledge.

- Crenshaw, K., 2005. Intersectionality and identity politics: learning from violence against women of color. In W. K. Kolmar & F. Bartkowski, ed. *Feminist theory. A reader*. New York: McGrawHill.
- Derrida, J., 1974. *Of Grammatology*. Baltimore: The John Hopkins University Press.
- Eco, U., 1976. *A Theory of Semiotics*. London: MacMillan.
- Foucault, M., 1969. *L'archéologie du savoir*. Paris: Gallimard.
- Koenis, S., 2008. *Het verlangen naar cultuur*. Amsterdam : Van Gennep.
- Lévi-Strauss, C., 1974. *The Savage Mind*. London: Weidenfeld & Nicolson.
- Lotman, Y., 1990. *Universe of the Mind: A Semiotic Theory of Culture*. Bloomington: Indiana University Press.
- Malouf, A., 1998. *Les identités meurtrières*. Paris: Grasset.
- Nietzsche, F., 1887. *Zur Genealogie der Moral*, available on the internet at Project Gutenberg.
- Ricoeur, P., 1984. *Time and Narrative*. Chicago: University of Chicago Press.
- Rigney, A., 2006. Plenitude, Scarcity and the Production of Cultural Memory. *Journal of European Studies*, 35,1(2), pp.209-26.
- Saussure, F. de, 1983. *Course in General Linguistics*. London: Duckworth.
- Sturrock, J., 1986. *Structuralism*. London: Paladin.
- Vattimo, G., 1989/2000. *La società trasparente*. Roma: Garzanti.
- Vier Minuten*, 2006. [Film] Directed by Chris Kraus. DE: EuropaCorp Distribution.
- The Fear*, 2009. [Music video] Song by Lily Allen. UK: Regal Recordings.

Coping or exiting BMES response to discrimination in construction

Paul Missa and Vian Ahmed, *School of the Built Environment, University of Salford*

Abstract

Notwithstanding that the construction industry has been perceived as a relatively low-status industry with hard and inflexible working conditions lacking any job security, and in addition, characterised by a persistent culture of white, male-dominated environment, Black and Minority Ethnic (BME) people are still underrepresented here. This negative image from being identified with stereotyped male values is still said to adversely affect recruitment to the industry. Despite public commitment on the part of sections of the industry towards equality and intolerance of racism, especially resulting from racial jokes and banter, a study has highlighted that BMEs are generally unaware of the rights that protect them from such racial and religious harassment in the workplace and resign to tolerance in order to avoid having to leave on their own or being forced out of the industry. Moreover, there has been the general notion that challenging the system through grievance procedures may affect one's career objectives which on the balance of research suggests the endurance of more negative than positive experiences. Having to suppress substantial parts of one's ethnic identity, for example, in order to progress through the system has been the norm for those in it while others, unable to cope, have had to quit. This literature based study therefore investigates the barriers and the perceptions of BMEs and the consequences of these on their uptake in the industry.

Keywords

Construction; Black and Minority Ethnic; Discrimination; Employment; Retention and Progression

1. Introduction and background

The construction industry accounts for about one-third of gross capital formation worldwide, amounting to between 5 and 7 percent of GDP in most countries and according to the Association of Colleges London Region (2008), is responsible for every type of work involved with building. As a result, there are jobs generated at

every stage in the life of such building - from designing and planning projects, to building, altering, decorating, restoring, maintaining and demolishing them. About half of all construction enterprises employ fewer than fifty workers; with a considerable percentage of the labour force being informal (Copplestone, 2006). The global construction industry is constantly changing and is client focused requiring timely completion of work within budget. Consequently, globalisation has caught up with the industry that requires mobile labour force with goods and services increasingly sourced internationally as a result of the global distribution of construction labour and output (Flanagan and Jewell, 2004; ILO, Sectoral Activities, 1998). The Engineering News Record (2005), valued global construction output at over US \$3.6 trillion in 2003. And, withal, this could be said to be an underestimation considering the limited statistics in developing countries. In Europe, the UK ranks third in construction output after Germany and Italy and with US \$212 billion while in Asia, Japan and Korea had had a significant construction output which has been overshadowed by the recent recession proof growth in China and India in particular, growth which lifts the region's construction output by an additional 2.6% even in the worst recession in recent history (Sleight, 2009; Flanagan and Jewel 2004).

Similarly, the UK construction industry is the main contributor accounting for approximately one-tenth of her Gross Domestic Product (GDP) and provides over half of the fixed capital investment (Steele and Todd, 2005). Being Britain's largest industry and the third largest in the EU, (Ahmed et al, 2008; Dainty et al, 2007; DTI, 2007) construction employs nearly 2 million people and there are also a large number who are indirectly engaged by the industry, creating a whole range of secondary employment which relies on a prosperous construction industry (Ahmed, et al 2008). Support, in the form of recruitment events, training, mentoring, professional networking, as well as work placement and experience schemes, expedites entry, retention and progression within the construction industry (Ahmed et al, 2008).

However, this well acclaimed industry has, traditionally, relied on young white males to form the majority of the workforce (Ahmed et al, 2008; Agapiou et al, 1995). As a result, minority groups, especially Black and Minority Ethnic people (BMEs) have been under-represented within the trade and professional occupations within the industry. In northern Europe, for example, the construction industry is clearly segregated. Members of the established minorities in Britain and in the Netherlands

account for only 2.3% and 2.2% respectively of the workforce in construction, compared with 6.9% and 8.9% respectively of the workforce in the economy as a whole. In contrast, however, in Italy and in Spain, where immigration is a more recent phenomenon, BMEs are over-represented in the industry compared with the economy as a whole. In Spain for example, while BMEs account for some 5% of the total economy-wide workforce, they represent some 9% of the legally employed workforce in construction (Byrne, 2004). In terms of horizontal segregation, therefore, while BMEs appear to be excluded in both the more and less regulated construction industries in the Netherlands, Denmark and Britain, immigrants are over-represented in the unregulated construction industries in Spain and Italy. Yet, in terms of vertical segregation, BMEs are in an especially vulnerable position as they are concentrated at the bottom of the occupational hierarchy in construction. Byrne et al, (2005) found a general overrepresentation of BMEs in the informal economy, working illegally, usually in sub-standard conditions and with no job or social protection, confined to the lower ranks of the occupational existing on the fringes of legality.

Nonetheless, demographic forecasts for the UK, for example, have indicated that the proportion of the BME labour supply will become increasingly prominent in future, particularly as the BME age profile is skewed towards young age groups (Ahmed et al, 2008; Ogbonna et al, 1995,). Faced with shrinkage of the traditional pool of applicants, as a result, the construction industry needs to look towards under-represented groups, such as those from the BME communities, to fill the ever growing vacancies within the industry. Thus, the participation of BMEs in the construction industry is vital in terms of meeting the industry's demand for labour and the shortfall of skills which creates strong opportunity for BME people to take advantage of the current skills shortage. However, this does not appear to be the case as BME consultants and contractors still continue to face barriers that limit their chances to take advantage of the growth in the industry (Steele and Todd, 2005).

2. Factors contributing to BMES underrepresentation

Although, the image of the construction industry itself has been found to be a major barrier for entry into construction (Ahmed et al, 2008, CABE, 2005), culture, language and religion also form immense barriers for a range of ethnic minority

people. A report, commissioned by CABE (2005) on Minority Ethnic Representation in the Built Environment professions in a research by the Centre for Ethnic Minority Studies at Royal Holloway, University of London, sought for answers to the many questions and attempted to explain the barriers facing black and minority ethnic (BME) professionals pursuing careers in the built environment. In it a model (figure 1) below which highlights the key issues either helping or hindering access to and progression as well as retention in the industry for BMEs is unveiled. Here, attempts are made at the various stages of the process from education through job seeking and employment to retention and progression to senior management with the helping and hindering factors at each stage well outlined. It is evident that in the process very few BMEs ever make it as indicated in figure 3 due to the many barriers in their way while the helping factors appear not to augur well in their favour.

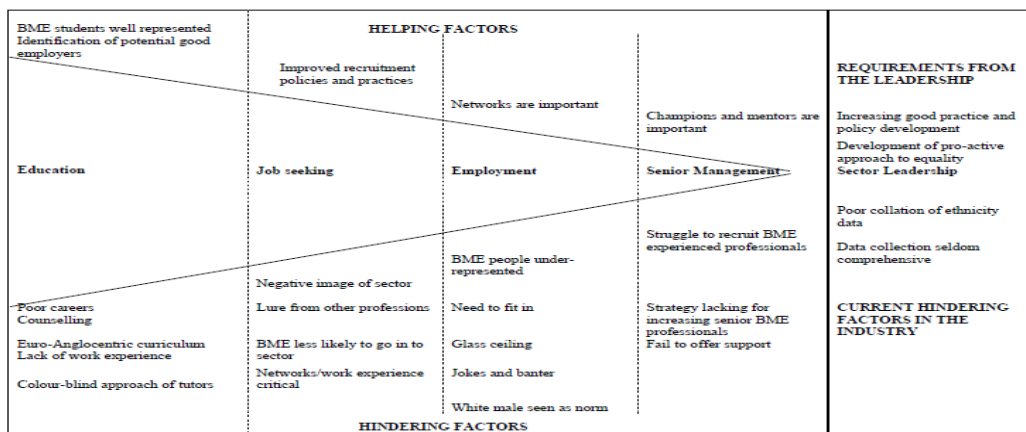

Source: The Commission for Architecture and the Built Environment (CABE), 2005.

Figure 1: BME Helping and Hindering Factors into Construction Employment

Additionally, the report calls on professional bodies, large employers and sector organisations to develop clear policies on equality and diversity and implement action plans for sufficient monitoring. The report also advises employers to review their recruitment policies and procedures, building on existing best practice, with the aim of making the sector's recruitment processes more inclusive. Related to the factors above are others already mentioned in the previous section and these are discussed below.

2.1 Culture

According to Schein, (1992) culture surrounds us all. Cultures are deep seated, pervasive and complex (ibid). Furthermore, culture has been proposed as 'the way in which a group of people solves problems and reconciles dilemmas' (Trompenaars and Hampden-Turner 1997). It is generally the way of life characteristic of a people and has also been said to be 'how we do things around here' (ibid). People's cultural traits are shaped by the various institutions they come into contact with, the culture of which has made them. Every institution has its own unique culture which is what identifies it from the rest, giving it its unique characteristics.

Therefore, acting appropriately and effectively in new cultures or among people with unfamiliar backgrounds and not floundering, according to Earley et al (2004), based on their anecdotal and empirical evidence suggests that a person with high cultural intelligence, whether cultivated or innate, can understand and master such situations, persevere, and do the right thing when needed and not rather based on their tacit knowledge, emotional or social intelligence. Moreover, Jackson (2002) claims that successfully negotiating the cross-cultural barrier can reduce other barriers, facilitating the development of trust in attempts to associate it with multiculturalism. This is upon creating the enabling environment which is usually achievable through cultural competency.

2.2 Language

A direct connection between culture and language has been established by some German romanticists of the 19th century such as Herder, who saw language not just as one cultural trait among many but rather as the direct expression of a people's national character (Anderson, 1983).

Consequently, the majority of BME people arrive in the host countries with languages and national characters other than what is in local usage while hoping to be able to communicate at a level comparable to their host nations' counterparts. This does not only pose a challenge, but also affects the way their employers and colleagues on a job react to them. Language has therefore been seen as a major barrier to the uptake of BMEs in the industry (Ahmed, et al, 2008; Cabinet Office Strategy, 2007; Construction Skills Network, 2007; DTI 2007; Gale A. and Davidson, M.J. 2006; CAGE, 2005). In their neighbourhoods, immigrants tend to rely on their native

language since many of them live separately from the host society. They therefore communicate more with their mother tongue in everyday life and as a result, tend to be isolated because other people fail to understand them.

In this regard, education and training of human capital defined as a sum of educational qualifications; skills, knowledge and experiences of a person which acts as a main determinant of labour market outcomes is brought to bear as Ethnic minority groups with significant variations in terms of education and training. On average, Indians, for example have higher levels of literacy, numeracy and skills than their White counterparts. In Ahmed, et al (2008), it was found that the average level of educational achievement of ethnic minorities exceeds the adult national learning achievements of the British White cohort. However, some groups of Pakistani and Bangladeshi backgrounds on average experience lower levels of educational attainment. For example, 37 percent of these ethnic groupings are at level 3 in the national qualification framework (the equivalent of two or more A-levels) compared with 46 percent of their White counterparts (Shield and Price, 2003). Although, a greater number of ethnic minorities face difficulties in English language which affects their social and economic integration it has however been found that immigrants who speak fluent English earn about 20 per cent more income (ibid).

Language is also an important driver of social capital which according to Colman (1988) is importance to the family and its children's educational outcomes. In fact, Platt (2005a) stresses the direct correlation between the success of future generations and their family characteristics which has also been confirmed by Amato (1998). Additionally, Colman (1998) stressed in this regard that the social capital of the family can be measured in terms of the strength of the relation between parents and children. This, of course, depends upon the physical presence of adults in the family and on the attention given by the adults to the child. For example, Colman found that the family network has an important effect on the likelihood of children to drop out of school and all this is influenced by their communication skills based on the strength of language.

Elsewhere in Norway, a study of ethnic minorities identified the important role social networks play in the integration of these groups in the labour market. The results of this study found that time spent in the labour market for ethnic minorities is essential

for their earnings rate and level of unemployment (Brekke, 2002). According to Borjas (1995) there is a growing appreciation of the potential influence that the social and economic environment of the country (in general) and household (in particular) has upon socio-economic outcomes. The existence of social capital and other forms of neighbourhood effects has crucial implications for a wide array of policy issues such as the creation and growth of a social underclass, including language and cultural persistence.

Moreover, another study by Herrington and Herrington (2004) in Switzerland on the transition from education to employment found that the social and economic background of parents has an impact on this process. For example, the educational level and occupational status of the parents at the date of the degree of their son/daughter are both significant in influencing them from obtaining employment. This means that a graduate has a higher probability of getting a job if at least one parent is in employment. Again, it was found that the graduates who have previous working experience are more likely to obtain a job than new graduates. In another study about Spain and Belgium, Kalter and Kogan (2006) measured the highest level of educational attainment of parents. They found that there were similarities between the indigenous population and youths from the EU in Belgium in terms of their highest level of education. While in Spain, the study found that the parents of immigrants from the EU states were more likely to be educated in comparison to the parents of the indigenous people, it was however found, in both countries, that the vast majority of Moroccan parents had only secondary education. It was also found that the social background of other non-EU immigrants were comparable to the social background of indigenous population.

2.3 Religion

Again, like language in the preceding section, religion also has a direct correlation with culture. Among several definitions of religion, the online dictionary.com offers a more comprehensive one as a set of beliefs concerning the cause, nature, and purpose of the universe, especially when considered as the creation of a supernatural agency or agencies, usually involving devotional and ritual observances, and often containing a moral code governing the conduct of human affairs. Religion has been known to pose as a disadvantage as a particular group's faith or religious characteristics affect their

performance in the labour market due to values or practices that affect their interaction with their host. Anecdotal evidence indicate that religious attributes strongly influence the labour market position of ethnic minorities, generally, yet according to the Fourth National Survey of Ethnic Minorities (FNSEM) in quantitative data in this field was limited. The most robust data set available in this area is the differences by religion in the share of the economically active population in paid work. They show that Muslim men and women were least likely to be in paid work, whilst Hindus were the most likely. Alternatively, disadvantages may be faced by a faith group due to the presence of prejudice and stereotypes that may exist about that faith group and may reflect people's negative attitudes towards that group. A combination of these factors may exist where Muslims are concerned and may in part explain their low levels of labour participation which may be identified as the 'Muslim Penalty' (Cabinet Office Strategy Unit, 2003).

However the relationship between religious groups and employment outcomes are not simple. Despite overall high Muslim unemployment rates, Indian Muslims have higher employment rates than Sikh men a reason for which religion has been said to be simply a proxy for other factors determining employment, like education and fluency. However, it has been found that the odds of being unemployed do vary significantly with religion (Brown, 2000). Even after controlling for a range of factors, Sikhs and Indians Muslims remain almost twice as likely to be unemployed as Hindus and Pakistani Muslims are more than three times as likely to be unemployed (ibid).

Looking at employment profiles and income differentials, there is also evidence of different experiences between religious groups as has been indicated by the Cabinet Office Strategy Unit, (2003). According to them, Sikhs, Pakistani and Bangladeshi Muslims show particular under-representation in professional employment, with this area showing higher concentrations of Hindus and Indian Muslims. In terms of earnings, Muslim men and women are overrepresented in the lowest income band. Almost a quarter earned less than £115 per week, compared to around one in ten Sikhs and Hindus. Yet despite over-representation among low earners, Indian Muslims actually record the highest share within the highest income band. Judging whether religion is a factor that affects the employment chances of a given individual is complex. Although differences between the outcomes experienced by religious

groups can be demonstrated, it is impossible to show causality. It is clear that Indian Muslims are strikingly different from South Asian Muslims in their achievement rates, suggesting that far more is at play than just religious effects. Moreover, significant signs of change for the young (second- and third-generations) are not apparent, indicating that the problems might well be more linked to specific group circumstances for which religion is a proxy, rather than religion itself.

Additionally, a study of construction in the North West of England found that ethnic minority people, particularly those of Asian or Muslim heritage, were seen as the representatives of their community suggesting that being Asian and Muslim forms the biggest potential barrier to acceptance by British society (Ahmed et al, 2008). Other evidence indicates that Asian Muslims find it difficult to discuss religion or religious practices such as fasting or some news items such as the Iraq or Afghan Wars or terrorist incidents without attracting criticism (ConstructionSkills, 2007). Ethnic minority managers often feel the intense pressure of scrutiny not to be seen to show preference to their own ethnic minority colleagues (Caplan and Gilham, 2007).

In effect, religion and religious practices have been an underlying divisive force in many instances as discussed above and this has resulted in the host nations reacting in a hostile manner towards, Muslims, for example. The recent attempts to attribute terrorism with Muslims after the bombings in the US and the UK have worsened the ill feelings, a situation which requires the understanding of the religion concerned. Earnings also seem to have a direct correlation with religion these are but a few of the factors that server rather as disincentive to the attraction of BMEs into the industries where such practices are a norm.

2.4 Large families and support networks

Primarily, BMEs have a culture to co-exist with the issue of having responsibility for the extended rather than the nuclear family, which may prove to be a disincentive to work and a drain on incomes. Large families and a lack of suitable accommodation can lead to overcrowding, which can be a barrier to doing well in education and employment. In a study however, it was found that the extended family arrangements can be supportive as it enabled members to remain out of work without significant financial hardship. Thus family support networks can take away some a lot of the pressure and urgency for finding work which is rather unlike their White

counterparts, for example (Tackey, et al (2006)). Contrary to this view however, the same study for the Department for Work and Pensions found that the high incidence of marriage can lead to individuals taking up employment as soon as was necessary to provide evidence responsibility to enable their partners to join them. As the focus at this point is on finding immediate employment, the jobs prospect are usually limited as it affects negatively the time invested in skills and training to move into a job with more opportunity for career progression.

3. Findings and Conclusions

Based on the aspects considered above through investigating the necessary literature, the findings that emerge give an overall picture of a vital industry bridled with acute shortage of skills, yet refusing to engage the group with a more sustained younger population and perpetuating similar business and procurement practices unlikely to widen the pool of labour. As a result, BMEs face limited opportunities in an industry that is not acting favourably enough to encourage them to enter it and progress. This under-representation is well pronounced in managerial and professional roles notwithstanding, the relatively high take-up of education and training courses in the industry by BME groups which, on balance, points to an interest from that section of the population.

Additionally, this situation is worsened by the prevalence of word-of-mouth recruitment and tendering practices which creates low levels of awareness within BME communities of the wide range of opportunities in construction as there is a lack of informal information networks within BME communities about work in the construction industry. Again, persistent perceptions of racism, the lack of implementation and monitoring of equal opportunities policies and diversity management makes it even less plausible for the BME to compete for jobs in construction. Furthermore, in the UK, for example, the fragmentation of the construction sector has resulted in creating many trades, small businesses and different, numerous roles which make it difficult to be monitored for good practice compared with other European counterparts.

Therefore, the resultant transformation from the various stages of an entrant into new culture can be enormous. These processes will vary as with cultural measurements, some originating cultures have characteristics similar to the host's and so are easily adaptable. Notwithstanding, the need to recognize difference and respect a multicultural coexistence remains the key to ensuring a fair representation of minorities and their coping or exit response to the experiences and perceptions of the industry. This process of multiculturalism is suitable for building a cohesive group that is capable of working as teams on construction projects.

4. References

- Agapiou, A., Price, A.D., and McCaffer, R. (1995), "Planning future construction skill requirements: understanding labour resource issues", *Construction Management and Economics*, 13(2) 149-61.
- Ahmed, V., Pathmewaran, R., Baldry, D., Worrall, L. and Abouen, S., (2008) 'An investigation into the barriers facing black and minority ethnics within the UK construction industry', *Journal of Construction in Developing Countries*, 13(2), 83-99
- Amato, P. (1998), 'More than money? Men's contributions to their children's lives', in: Booth A. and Creuter A. (eds) *Men In Families: When Do They Get Involved? What Difference Does It Make?*, New Jersey, Lawrence Erlbaum.
- Anderson, B.R. (1983) *Imagined Communities: Reflections on the Origin and Spread of Nationalism*. London: Verso.
- Ankrah, N., Proverbs, D., Antwi, A. and Debrah, Y. (2005), "Factors influencing organisational culture: a construction project perspective", in Egbu, C. and Tong, M. (Eds), *Proceedings of the PROBE 2005 Conference*, Glasgow.
- Ankrah, N.A. and Langford, D.A. (2005), "Architects and contractors: a comparative study of organizational cultures", *Construction Management and Economics*, 23(6), 595-607.
- Association of Colleges, London Region (2008) available at: http://www.londoncolleges.com/en/working_in_london/Construction/studying-and-working-in-construction/ (accessed on 12 February, 2010)
- Barthorpe, S., Duncan, R. and Miller, C., (2000) "The Pluralistic Facets of Culture and its Impact on Construction". *Property Management*. 18(5), 335-51.

- BERR (2007) Construction Statistics Annual 2007, *Department for Business, Enterprise and Regulatory Reform (HMSO)*, London.
- Berry, J. W. (2005) Acculturation: Living successfully in two cultures. *International Journal of Intercultural Relations*, 29, 697-712.
- Berry, J. W., and Kalin, R. (1995). Multicultural and ethnic attitudes in Canada. *Canadian Journal of Behavioural Science*, 27, 310–20.
- Berry, J. W., Poortinga, Y. H., Segall, M. H., and Dasen, P. R. (2002). *Cross-cultural psychology: Research and applications* (2nd ed.). New York: Cambridge University Press.
- Berry, J.W. (2005) Acculturation: Living successfully in two cultures, *International Journal of Intercultural Relations*, 29, 697-712.
- Brekke, I. (2007) Ethnic Background and the Transition from Education to Work among University Graduates, *Journal of Ethnic and Migration Studies*, 33(8) 1299 - 1321
- Brown, M. (2000) 'Religion and Economic Activity in the South Asian population', *Ethnic and Racial Studies*, 23(6) 1045.
- Byrne, J., Clarke, L. and Van Der Meer, M. (2005) 'Gender and ethnic minority exclusion from skilled occupations in construction: a Western European comparison', *Construction Management and Economics*, 23(10), 1025 - 1034
- CABE (2005), Black and Minority Ethnic Representation in the Built Environment Professions, *Royal Holloway University of London*, CABE
- Cabinet Office Strategy, Cabinet office/Strategy Unit and National statistics. (2002). Labour market. <http://www.statistics.gov.uk/cci/nugget.asp?id=271> (Accessed 2 June 2009).
- Cameron, K. S. and Quinn, R. E. (1999), *Diagnosing and changing organizational culture: Based on the competing values framework*. Reading, MA: Addison-Wesley.
- Cameron, K.S. and Quinn, R. E. (2005) *Diagnosing and Changing Organizational Culture: Based on the Competing Values Framework*, San Francisco: Jossey-Bass.
- Caplan, A.S. and Gilham, J.L. (2005) 'Included against the odds: failure and success among minority ethnic built-environment professionals in Britain'. *Construction Management and Economics*, 23(10), 1007–15
- Centre for Construction Innovation (2008). Construction and BME (Black and Minority Ethnic) Project. *European Social Fund*. Salford, University of Salford.

Centre for Ethnic Minority Studies (2000) *The Impact of Race and Gender on Progression from GNVQ Construction into the Industry* (for CITB), Centre for Ethnic Minority Studies, Royal Holloway, University of London.

Centre for Ethnic Minority Studies (2002) *Retention and Career Progression of Black and Asian People in the Construction Industry*, Royal Holloway University of London, CITB

Centre for Ethnic Minority Studies (CEMS), (1999) *The Under-Representation of Black and Asian People in Construction*, Royal Holloway University of London, CITB

CITB (2001). *Construction Employment and Training Forecast Annual Report 2001*, CITB

CITB (2002) *Construction Employment and Training Forecast 2002 – 2006*, CITB.

CITB (2003). *Construction skills and foresight report*. <http://www.citb.co.uk> (Accessed 24 May 2009).

Coleman, J. (1988), 'Social capital in the creation of human capital', *American Journal of Sociology*, 94, 95-120.

Commission for Architecture and the Built Environment (CABE) (2005), *Black and Minority Ethnic Representation in the Built Environment Professions*, commissioned research from the Centre for Ethnic Minority Studies, Royal Holloway University of London, CABE

Commission for Racial Equality (2007), "Ethnic Minorities in Great Britain". Fact File 2. *Conflict and Racial Discrimination in Construction*. Politics and Society

Constructing Excellence (2004), "Culture and people", available at: www.constructingexcellence.org.uk (accessed 16 December 2009).

Construction Skills Network. (2009). *Construction Skills Network Labour Market Intelligence*. [http:// www.ConstructionSkills.net/pdf/research/outputs/NW_LMI. pdf](http://www.ConstructionSkills.net/pdf/research/outputs/NW_LMI.pdf) (Accessed 11 February 2010).

ConstructionSkills (2007) *Deconstructing Barriers: Full report and Recommendations*, ConstructionSkills

ConstructionSkills (2009) *SkillBuild* available at: <http://www.cskills.org/newsandevents/news/SB09dates.aspx> (access, 23 March 2010)

Copplestone, P. (2006) *Vietnam: The Vital Construction Industry*, mimeo, World Bank.

Dainty, A., Grugulis, I. and Langford, D. (2007). Understanding construction employment: The need for a fresh research agenda. *Personnel Review*, 36(4): 501–508

Dainty, A.R.J. and Bagilhole, B. M. (2005) Equality and diversity in construction: guest editorial. *Construction Management and Economics*, 23(10), 995–1000

Department of Trade and Industry, National Statistics, (2005) Statistical Press Release, available at: http://www.sbs.gov.uk/SBS_Gov_files/researchandstats/SMEStats2004.pdf (accessed on 23 January, 2009)

Department of Trade and Industry. (2007). <http://www.dti.gov.uk> (Accessed 19 May 2009)

Earley, P. C. and Mosakowski, E. (2004), Cultural Intelligence ‘Harvard Business Review’, Harvard Business School Publishing

Engineering News Record (2005) Global Construction Output, available at: <http://enr.construction.com/> (accessed 23 June, 2009)

Flanagan, R. and Jewel, C. (2004), “International Competitiveness of the Finnish Construction Sector”, Working Paper, *School of Construction Management and Engineering*, University of Reading, UK

Gale, A.W. and Davidson, M.J. (Eds.). (2006). *Managing Diversity and Equality in construction: Initiatives and Practice*. London: Spon Press (Taylor and Francis).

Greater London Authority (2007) ‘The Construction Industry in London and DiversityPerformance’, *Mayor of London*.

Hofstede, G. (2005) *Cultures and Organizations: Software of the Mind*, (2nd Ed.), New York: McGraw-Hill.

ILO Sectoral Activities, (1998), available at: <http://www.ilo.org/public/english/dialogue/sector/sectors/constr.htm> (accessed, 23 April, 2009)

International Training Federation (ITF), (2009) International Responses to the Recession, available at: <http://www.itf.org.nz/international-responses-to-the-recession.html>, accessed on 23 January, 2010.

Jackson, V. (2002), “Cultural competency”, *Behavioral Health Management*, 22(2), 20-6.

Kalter, F and Kogan, I. (2006) Ethnic inequalities at the transition from school to work in Belgium and Spain: Discrimination or self-exclusion? *Research in Social Stratification and Mobility*, 24(3), 259-274

- Ogbonna, E. and Noon, M. (1995) Experiencing Inequality: Ethnic Minorities and the Employment Training Scheme. *Work, Employment and Society*, 9(3), 537-58
- ONS (2004), "Labour Market Data for Local Areas by Ethnicity". http://www.statistics.gov.U.K./articles/nojournal/LM_Data_Ethnicity.pdf (Accessed on 27 September 2009)
- Peters, T.J. and Waterman, R.H. (1982), *In Search of Excellence: Lessons from America's Best-Run Companies*, New York, NY: Harper and Row.
- Platt, L. (2005a) The intergenerational social mobility of minority ethnic groups. *Sociology*, 39(3), 445-46
- Race for Opportunity, (2008) Race to the Top: The place of ethnic minority groups within the UK workforce, RfO
- Schein, E. (1985) *Organizational Culture and Leadership*, London: Jossey-Bass Publishers.
- Shein, E. (1992), *Organizational Culture and Leadership*, 2nd ed., San Francisco, CA' Jossey-Bass.
- Shields, M. and Wheatley Price, S. (2003). 'The labour market outcomes and psychological well-being of ethnic minority migrants in Britain', Home Office Online Report, available at: <http://www.homeoffice.gov.uk/rds/pdfs2/rdsolr0703.pdf> (accessed on 15 January, 2010).
- Sleight, A. (2009), available at: <http://www.khl.com/> (accessed, 10 January, 2010).
- Steele A. and Todd S. (2005). The Future of the Black and Minority Ethnic Construction Sector in England. *Construction Management and Economics*, 23: 1017-1023.
- Tackey, D. N., Casebourne, J., Aston, J., Ritchie, H., Sinclair, Tyers A. C., Hurstfield, J., Willison, R. and Page R. (2006), Barriers to employment for Pakistanis and Bangladeshis, *Department for Work and Pensions HMSO*, Leeds
- Trice, H. (1993), *Occupational Subcultures in the Workplace*, ILR Press, Ithaca, NY, .
- Trice, H.M. and Beyer, J.M. (1993) *The Cultures of Work Organizations*, Englewood Cliffs, NJ: Prentice-Hall.
- Trompenaars, F. (2003) *Did the Pedestrian Die?: insights from the greatest culture guru*, Oxford: Capstone Publishing.
- Trompenaars, F. and Hampden-Turner, C. (1998) *Riding the Waves of Culture: understanding diversity in global business*, (2nd. Ed.), New York: McGraw-Hill.

TUC, (2009), Skills in the recession, available at:
<http://www.tuc.org.uk/extras/skillsintherecession.pdf> accessed, 16 February, 2010.

Twomey, B. (2001). Labour market Participation of ethnic groups. *Labour Market Trends*, 109, 29–4

Van Maanen, J. and S. Barley (1984) Occupational Communities: Culture and control in organizations. *Research in Organizational Behaviour*, 6, 287-365.

Structural impact study of “ideal” 3D aluminium foam

Sathish Kiran Nammi, Peter Myler and Gerard Edwards

School of Built Environment and Engineering, University of Bolton

Abstract

The architecture of closed-cell aluminium (Al) foam was represented with three dimensional arrays of a repeating unit-cell (RUC) which was constructed from tetrakaidecahedra. This RUC takes the tetrakaidecahedron edge-length and shell thickness as input parameters to define its geometry. By then assigning material properties of aluminium to this geometry, finite element (FE) models of Al foam were prepared. Impact velocities in the range of 1 to 10 m/s were given to an indenter of mass 5 kg and impacted against the FE model of Al foam. These simulation results were compared against impact test conducted on real Al foam using Instron-Dynatup™ drop hammer rig. The residual velocity characteristics of indenter as predicted by the FE model were in close agreement with the results obtained experimentally.

Keywords

Aluminium, Foam, Johnson-Cook model, Strain-rate, Finite element

1. Introduction

Closed-cell aluminium (Al) foams have potential applications in armour vehicles due to their energy absorption and stress wave attenuation features (Bazle (2001)). As such, the finite element (FE) models of Al foam are of great usage. The structure of closed-cell Al foam is made of cells of various sizes and shapes which are randomly distributed within its microstructure. Therefore, modelling closed-cell Al foams is challenging due to high degree of inhomogeneity in its cellular structure. However, simplified models of Al foam with periodic structure, which are constructed from space filling polyhedrons are a useful initial approach to understand the mechanical behaviour of foam. In the present work, Al foam was represented with 3D arrays of a

repeating unit-cell (RUC) which were constructed from tetrakaidecahedra. This model was impacted with a blunt projectile.

Impact energy absorbing structures can be classified into two generic types depending on their quasi-static compressive response characteristics, these being “Type I” and “Type II” (Calladine and English (1984)). If the quasi-static load-deformation response produces a relatively flat topped curve in the neighbourhood of peak load, it is of “Type I”. On the otherhand, the “Type II” structures display an initial peak load which is then followed by a steep drop. A schematic of these two types of load-deformation responses are shown in Figure 1. It should be noted that the aluminium (Al) foams behave like “Type I” structures (Deshpande and Fleck (2000)).

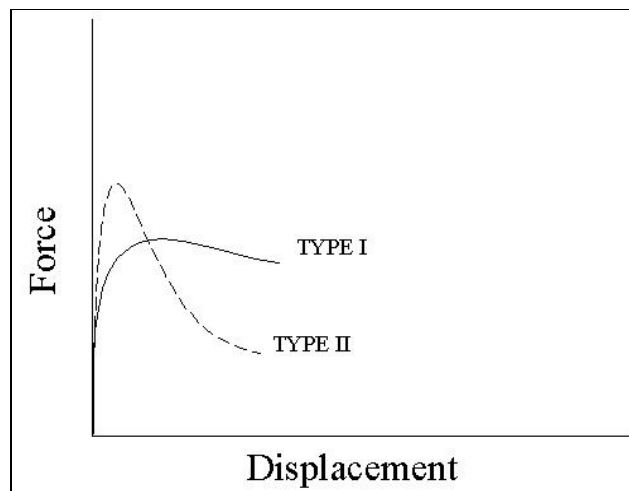

Figure 1: Illustration of two types of generic structures

In literature, the repeating unit-cell (RUC) based approach is often found to model the compressive response of closed-cell Al foam. Two of such models are namely, the truncated-cube (Sigit Santosa & Tomasz Wierzbicki (1998)) and cubic-spherical lattice (Meguid et.al (2002), Kim et.al (2006), Tunvir et.al (2007)). These researchers treated Al foam as ordered arrays of RUCs and have carried out crush simulations using finite element method. However, when their load-deformation response was studied under quasi-static conditions, these models displayed characteristics of typical “Type II” structures. In contrast, Al foams are experimentally observed as “Type I” structures. There is a need to develop an RUC

model which gives the “Type I” response. Previously, the authors (Nammi et.al (2010)) introduced an RUC (shown in Figure 2) which was constructed from tetrakaidecahedra and which produces a “Type I” load-displacement response. The work presented in this paper extends the FE analysis to low velocity impact studies using the same RUC previously investigated for quasi-static loading.

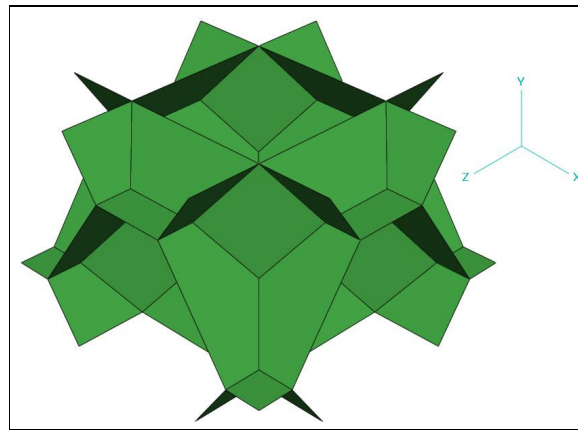

Figure 2: Repeating unit-cell (RUC) of closed-cell Al foam

2. Finite element analysis

A micromechanical model made of 48 repeating unit cells (RUCs) was constructed to represent closed-cell Al foam using ABAQUS FE code. The RUC is of a constant edge-length $1815 \mu m$ and shell thickness $170.97 \mu m$. With these quantities an Al foam FE model of relative density of 0.11 was constructed, consistent with the relative density of the Al foam specimens that were experimentally tested. The formulation for the relative density of this FE model can be derived as follows:

$$\frac{\rho^*}{\rho_s} = 1.1837 \frac{t}{l} \quad (1)$$

Here ρ^* and ρ_s are the densities of foam and intrinsic material, t and l are the thickness and cell-edge length of the RUC.

The FE model was given with material property data of Al 2024-T3. Strain-rate effects as described in Johnson-Cook (J-C) plasticity model were adopted. The constitutive equation of J-C can be described as follows

$$\sigma = (A + B\varepsilon^n)(1 + C \ln \dot{\varepsilon}^*)(1 - T_h^m) \quad (2)$$

Where A , B , C , n and m are parameters obtained experimentally, σ is the effective yield stress, ε is the plastic strain, $\dot{\varepsilon}^*$ is the normalized effective plastic strain-rate ($\dot{\varepsilon}^* = \dot{\varepsilon} / \dot{\varepsilon}_0$, $\dot{\varepsilon}$ is the applied strain rate and $\dot{\varepsilon}_0$ is the reference strain rate), T_h is the homologous temperature given as follows: $T_h = \frac{T - T_{room}}{T_{melt} - T_{room}}$, here T is the current temperature, $T_{room} = 25^\circ C$, the room temperature and T_{melt} is the melting point. The J-C model quantities applied in FE model were $A = 369.0MPa$, $B = 684.0MPa$, $C = 0.0083$, $n = 0.73$, $m = 1.7$ and T_{melt} was $502^\circ C$; all these parameters were taken from the reference (Lesuer, 2000).

Modelling the progressive damage and failure in Al foam in the neighbourhood of the advancing indenter is complex and requires the knowledge of material failure mechanisms. We assigned shear failure criteria to elements of Al foam which come in contact with the perimeter of blunt indenter based on experimental observation and results from previous macroscopic FE models (Lu et al (2008)). A fine mesh was used in the neighbourhood of indenter impact zone all the way through the depth of foam structure, as this region will experience rapidly varying stress/strain field in space and time. A coarse mesh was used for regions remote from the neighbourhood of the indenter impact zone. A diagram showing fine mesh and coarse mesh zones is presented in Figure 3.

The “ideal” Al foam target was impacted at the centre with the rigid indenter. All free nodes of Al foam on xy and xz planes were fully constrained. The indenter was modelled as a rigid body and was assigned with initial impact velocities in the range of 1 to 10 m/s . The velocity history for the indenter motion, for a set of five different impact velocities $v_i = (1, 2, 5, 8, 10) m/s$ is shown in Figure 4. The velocity of the

indenter decreases in all five cases for increasing time as its energy is transferred to the target. The FE simulation images showing the spacial degree of penetration of the indenter, for a series of time snapshots, with an impact velocity of $v_i = 10 \text{ m/s}$, is shown in Figure 5.

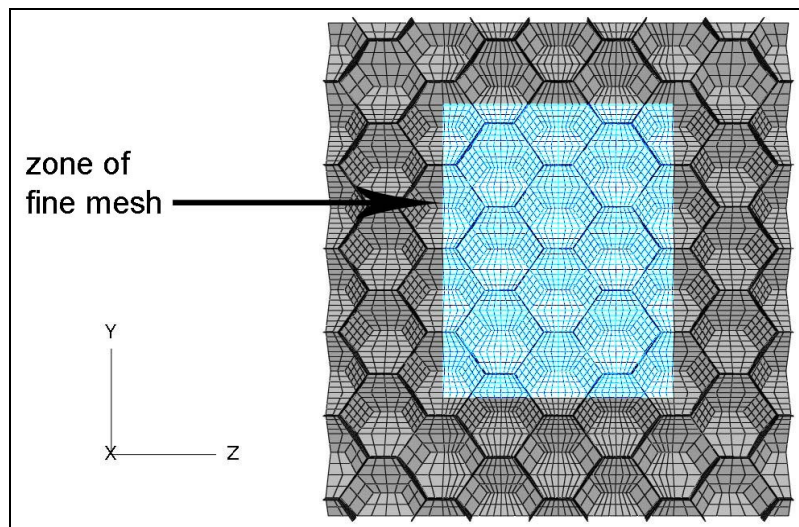

Figure 3: FE model of Al foam with fine mesh zone surrounded by coarse mesh

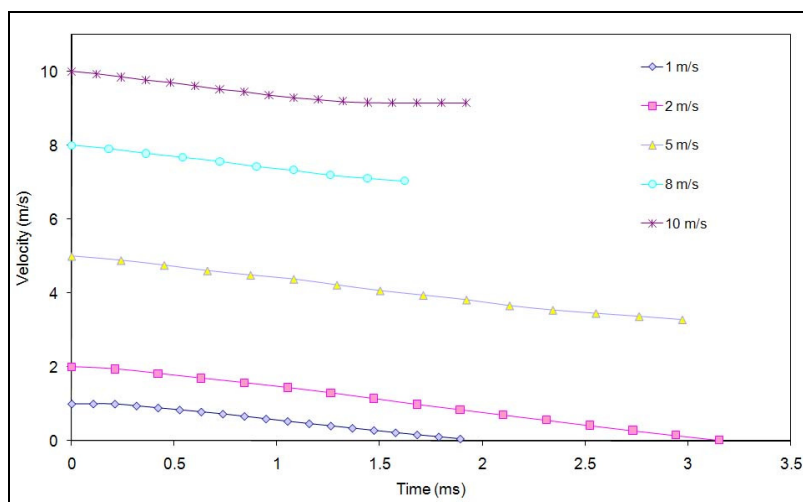

Figure 4: Velocity-time history of indenter from FE simulations for a set of five impact velocities $v_i = (1,2,5,8,10) \text{ m/s}$

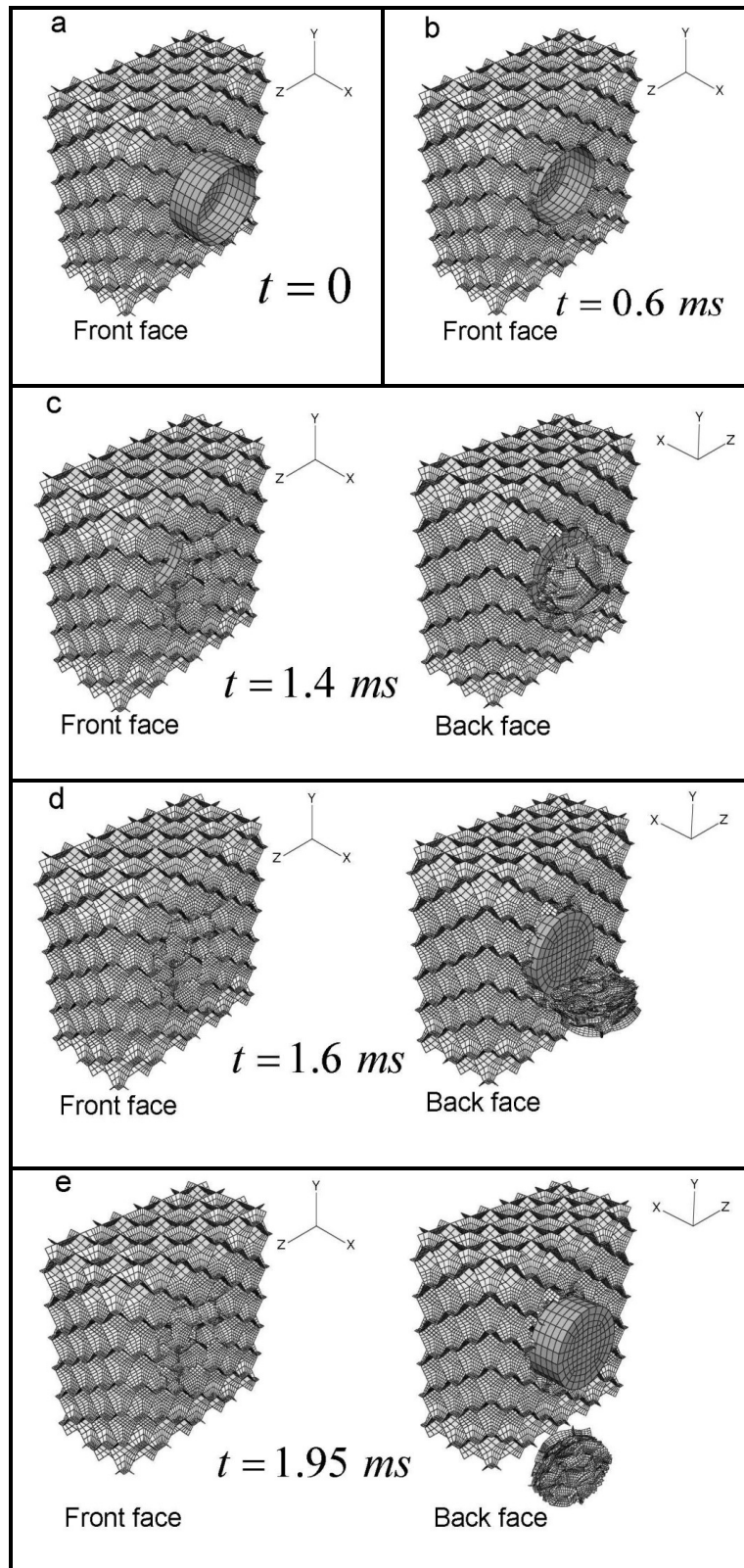

Figure 5: Snapshots of a impact simulation for impact velocity $v_i = 10\text{ m/s}$

3. Experimentation and comparison with FE result

Low velocity impact tests were carried out using instrumented Instron-DynatupTM test rig. The real Al foam samples were impacted with a blunt striker of 12 mm diameter which was fitted to a tup of mass 5 kg. The residual velocity of indenter, as it penetrates through the Al foam is shown in Figure 6, where the indenter was released from a height of $\approx 190\text{mm}$, producing an initial velocity of $\approx 1.92\text{m/s}$ which is consistent with Newton's laws for free-falling objects.

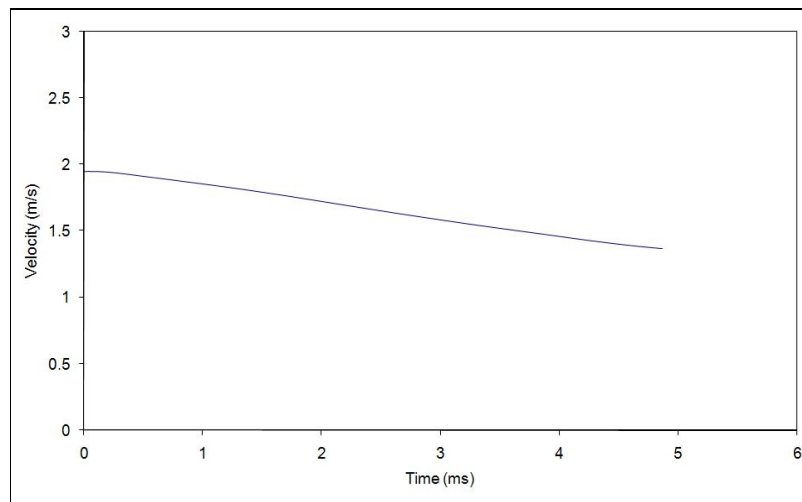

Figure 6: Velocity-time history from experiment

4. Discussion and conclusion

The focus of this investigation was the FE modelling of impact dynamics for an Al foam treated as a periodic cell structure and in particular the calculation of the indenter residual velocity. A blunt indenter creates high stress concentrations on the material which comes in contact around its perimeter edge. As a result, the elements in the zone of indenter edge attained critical shear stress for failure even at much lower indentation depth. The experiments also showed the tearing of foam specimens around the zone of contact with the indenter edge. Furthermore, the simulation showed the crushing of foam cells ahead of indenter's flat-face. Figure 5 shows the indenter penetration, all the way through the depth of FE model, from two different viewpoints close to the front and the back faces. This depth of crushing was seen to be

proportional to the initial impact velocity of indenter for the simulated range of 1 to 10 m/s . Thus, we conclude that, for the simulation to produce behaviour consistent with the experiments, it is necessary to assign shear failure criteria for the elements around the perimeter edge for blunt-indenter.

It can be shown that the residual velocities of the indenter as predicted by FE model were similar to that obtained from experimental result (see Figure 4 and Figure 6). However, it was found that our “ideal” foam was significantly stiffer compared to real Al foams. For example, when the indenter was given an impact velocity of 2 m/s , the FE simulation showed that the indenter was completely contained within Al foam after 3 ms . However, experiments conducted on real Al foam sample for an impact velocity $v_i \approx 1.92m/s$ showed that indenter still had a residual velocity of 1.63 m/s after 3 ms . This difference is due to the fact that real Al foams have a random structure of cavities, in terms of their position and size which weakens their strength.

In summary, the results of our FE simulations, for the tetrakaidecahedra based RUC model demonstrate that Al foams represented by an underlying periodic cell structure, can be usefully applied to impact studies.

5. References

- Bazle A. Gama., Travis A. Bogetti., Bruce K. Fink., Chin-Jye Yu., T. Dennis Claar., Harald H. Eifert and John W. Gillespie Jr (2001) ‘Aluminum foam integral armor: a new dimension in armor design’, *Composite Structures* 52, 381-395.
- Calladine, C.R and English, R.W (1984) ‘Strain-rate and inertia effects in the collapse of two types of energy-absorbing structure’, *International Journal of Mechanical Sciences*, volume 26, Issues 11-12, pages 689-701.
- Deshpande, V.S and Fleck, N.A (2000) ‘High strain rate compressive behaviour of aluminium alloy foams’, *International Journal of Impact engineering* 24, 277-298.
- Kim, A., Tunvir, K., Jeong, G.D and Cheon, S.S (2006) ‘A multi-cell FE-model for compressive behaviour analysis of heterogeneous Al-alloy foam’, *Modelling and Simulation in Material Science and Engineering* 14, 933-945.

- Lesuer, D.R (2000) 'Experimental Investigations of Material Models for Ti-6Al-4V Titanium and 2024-T3 Aluminum', Technical Report, DOT/FAA/AR-00/25, U.S. Department of Transportation Federal Aviation Administration Office of Aviation Research Washington, DC 20591.
- Lu, G., Shen, J., Hou, W., Ruan, D and Ong, L.S (2008) 'Dynamic indentation and penetration of aluminium foams', International Journal of Mechanical Sciences 50, 932-943.
- Meguid, S.A., Cheon, S.S and El-Abbasi, N (2002) 'FE modelling of deformation localization in metallic foams', Finite Elements in Analysis and Design 38, 631-643.
- Nammi, S.K., Myler, P and Edwards, G (2010) 'Finite element analysis of closed-cell aluminium foam under quasi-static loading', Materials and Design, Volume 31, Pages 712- 722.
- Sigit Santosa & Tomasz Wierzbicki (1998) 'On the modeling of crush behaviour of a closed-cell aluminum foam structure', Journal of the Mechanics and Physics of Solids, Volume 46, Issue 4, Pages 645–669.
- Tunvir, K., Kim, A and Cheon, S.S (2007) 'Analytical Solution for Crushing Behavior of Closed Cell Al-Alloy Foam', Mechanics of Advanced Materials and Structures, 14:5, 321-327

An Application of the Activity-Based Costing for the Management of Project Overheads to Increase Profit during the Construction Stage

Nyoman M. Jaya, Chaminda P. Pathirage and Monty Sutrisna

School of the Built Environment, the University of Salford

Abstract

The traditional costing system was originally developed in England when industrial engineers and cost accountants applied a primary concept of cost accounting system to minimise the risk of bankruptcy during times of recession. The conventional Bills of Quantities (BoQ) arbitrarily distributed average overheads to the real jobs or projects on direct labour basis. There would seem to be an invisible cost-causal relationship between overheads and activities. Project overheads are indirect costs that not necessarily defined in close relation to activities. The Activity-Based Costing (ABC) system enables it to assign indirect costs to every activity, then to jobs or projects. This paper aims to investigate an application of the ABC system for the management of project overheads to increase profit during construction operations and to develop a cost controlling concept, through a thorough review of literature and a critical discussion. The ABC system provides diverse cost drivers in assigning accurately the project overheads to every activity and demonstrates clear insights of cause-and-effect relationships to the jobs or project packages. The ABC system would, therefore, be implemented suitably to develop the Activity-Based Cost Controlling (ABCC) model for the management of project overheads, and as a cost controlling tool and technique to increase profit during the construction stage in the construction industry.

Keyword:

Activity-based costing, project overheads, cost controlling, profit, construction stage.

1. Introduction

The old traditional costing system has been well established for estimating direct costs such as materials and labour (Daly, 2002). The conventional BoQ was developed for several decades, even now widely used in the UK and overseas (Sutrisna *et al.*, 2004). A percentage addition of indirect overheads and profit based on contractor' building costs (RICS, 2009; and CIOB, 2009). It provides uncertain information to produce cost planning and controlling, and arbitrarily allocates overheads to a real project on the unit of direct labour basis (Mansuy, 2000). Unfortunately, the direct labour has a poor relevancy with indirect overheads. The indirect overheads are not defined clearly related to activities. Continuous developments of a contemporary cost accounting system should be concentrated on assigning indirect overheads that are not specifically associated to activities, jobs or projects. The ABC system will provide a good opportunity to assign the project overheads accurately to every activity and those activity costs can be accumulated to jobs or projects based on relevant cost drivers. This mechanism is in line with a philosophy of the ABC system, where, jobs and products or services consume activity costs, and those activities consume resource costs (Cooper and Kaplan, 1988; Kaplan and Cooper, 1998; Hicks, 1992; and 1999; Kaplan and Anderson, 2007; Drury, 2008).

Contractors' perspective on the project implementation argues that project cost overruns must be prevented to help the affordability of projects from tough profit margins and the project expenditures must be properly controlled. Whenever construction materials and labour are budgeted very tightly, then the overheads become an important component for the existence of contractor business. The project overheads therefore should be considered as a fundamental cost to be manipulated potentially on controlling costs and managing project overheads for generating profit during construction operations. The following parts of this paper will discuss the important aspects of the project overheads; the underpinning philosophies of the ABC system; the application of the ABC system in the construction projects; and cost controlling tool and technique for the management of project overheads.

2. The Importance of the Project Overheads

The UK's economy is vitally linked with the construction industry that was ranked in the 'global top ten' (UK Corporate Watch, 2004). It accounted for 7.3% of the UK's Gross Domestic Product (GDP) in mid 1990s (The Scottish Government, 2004), 8% in 2005 (RocSearch Ltd., 2006; and General UK Statistics, 2007), 8.5% in 2008 rising to 10% overall when the entire value chain and a driver of historical GDP growth are considered (UK Construction Group - UKCG, 2009). The UK construction industry is the second largest in the EU with a contribution about 8.2% of the nation's GVA-gross value added (General UK Statistics, 2007). The total output of the construction industry in Great Britain was estimated at £123.24 billion in 2008, an increase of 20.5% on the figure for 2004 (Construction Industry Market Review, 2009). It involved about 300,000 construction companies, employed 3 million people (represented 8% of UK employment) that a 40% is higher skilled labourers (UKCG, 2009). According to McGraw Hill Construction, a worldwide construction industry output is estimated US\$ 4.6 trillion that contributed 10% of global GDP (General UK Statistics, 2007). The US's construction industry sector has spent approximately by US\$1.155 trillion that represented 9% of its' GDP in 2006 (Sears *et al.*, 2008; Gould and Joyce, 2009), 11% in the EU and 8.4% in Chile (Alarcón *et al.*, 2009). Construction industry demands large resources that supply from other prospective producers (Alarcón *et al.*, 2009). Construction projects appear to have a high spending, complex and intricate projects that require various resources which included human, funds, equipment, and materials (Lock, 2004; and Walker, 2007).

Complexity of the projects generally characterise by an intricate nature and a cyclical business that inevitably spend lots of time and resources. Construction projects critically link and very much dependent upon a wide variety of other industry sectors. The resources with uncertain information that are available at the remote positions often require a lot of time and too expensive to collect, analyse, and to be feasible on the site of project (Sears *et al.*, 2008; and Winch, 2009). The increasing sophistication of construction clients and the complexity of their needs have based their selection criteria for contractors on the best value principles rather than lowest cost (CIOB, 2009). The project complexity, sophisticated demands, diversities and fragmented project packages may cause construction operation becoming very difficult which

involve other parties with own interests and intricate business itself. These may require higher investments and advanced technologies. On such changing environments, indirect overheads tend to increase compared to project direct costs (Ostwald, 2001; Kim and Ballard, 2002 and 2005).

Assaf *et al* (2001) argued that majority of contractors thought and experienced that project overheads have been increased during previous years, and may continuously be arisen in the next coming years. Hence, 77% of surveyed contractors had a significant increase in overheads, while 9.8% unchanged, and only 13.2% decreased. Overheads constitute a significant portion of construction costs (Assaf *et al.*, 2001; and Enshassi *et al.*, 2008). Most literature describes that project overheads range between 8% and 15% depending on the project characteristics. General term of overheads in the construction projects is made up of two groups: home-office overheads (e.g., executive and staff salaries, office rent and insurance, supplies, donations), and site-project overheads (e.g., depreciation, power, superintendent, storage, job-site expenses), and many others (Kim and Ballard, 2001; Assaf *et al.*, 2001; Ostwald, 2001; Aretoulis *et al.*, 2006; Enshassi *et al.*, 2008). The project overheads have increasingly becoming an important issue which is highly required to sustain entire projects and contractor's business. Therefore, the ABC system with cost drivers may accurately assign overheads to every activity.

3. The Underpinning Philosophies of the ABC System

The traditional costing system was initiated in England in the middle part of the 18th century, when the industrial engineers and cost accountants such as Josiah Wedgwood on the year 1754 developed a primary concept of cost accounting system to minimise the risk of bankruptcy during recession (Giroux, 1999). A fundamental change began at the end of the 20th century, rolled by the Consortium for Advanced Management – International (CAM-I) toward evolutions of the contemporary ABC concept. An underpinning philosophy of the ABC system is defined as “the jobs, products, and services an organisation provides require it to perform activities, and those activities cause it to incur costs” (Hicks, 1999, p.50). This definition is used for underlining further applications of the ABC system in the construction projects, where cost is

caused by activity, causes of the costs can therefore be managed, and triggers of the costs should be controlled. Project costs, activities, management, and controlling can be considered important aspects for the management of project overheads during the construction stage.

Contemporary ABC system can be distinguished from simplistic traditional costing system (refer to figure 1). The ABC system utilises reliable hierarchy process and diverse cost drivers in assigning organisation's indirect costs to every activity, and those activity costs are accumulated on multiple cost objects, while simplistic traditional systems use volume-based allocations (Kim and Ballard, 2005) for accumulating overheads directly to cost objects on the basis of direct labour (Mansuy, 2000).

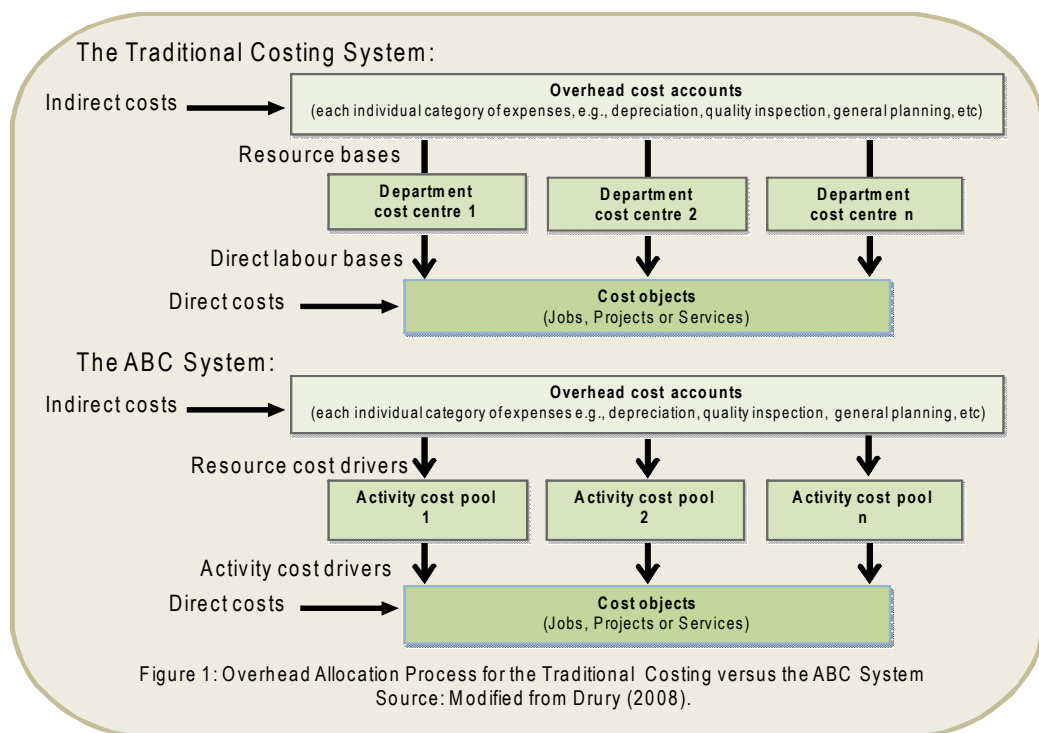

Major differences between a simplistic traditional system and a contemporary ABC system can be summarised in table 1 based on the works done by the authors such as: Cooper and Kaplan (1988); Innes and Mitchell (1998); Hicks (1992 and 1999); Mansuy (2000); Grannof *et al* (2000); Cokins (2001); Daly (2002); Kaplan and Anderson (2007); and Drury (2008).

Table 1: Major Differences between Simplistic Traditional System and Sophisticated ABC System

Criteria	Simplistic Traditional Costing System	Contemporary ABC System
Interpretation of resource consumptions	Resource costs are directly consumed by cost objects	Resource costs are consumed by activities, then those activity costs are consumed by cost objects
Orientation of cost accounting	The basis of cost accounting is orientated on departmental structure of the organisation	The basis of cost accounting is orientated on hierarchical activities of the process
Utilisation of cost drivers	Cost accounting mostly employs volume-base allocations at single rate of unit level costs	Cost accounting use activity hierarchy levels at multiple rates of cost drivers such as unit level, batch level, product level, and facility sustaining
Concern on cost objects	It focuses on estimating single type of cost objects by the single rate of unit level for measuring the products and services	It interests on estimating multiple types of cost objects by the multiple rate of cost drivers for sustaining the jobs, products, and services
Specific distribution of overheads (advantages / disadvantages)	It allocates prorated overheads and brings a problem of cost distortions, because of its' inability to highlight the visibility of cost to cause-and-effect relationships	It assigns overheads per activity to avoid a problem of cost distortions, because its' ability to highlight the visibility of cost to cause-and-effect relationships
Relative monetary value of accounting systems (potential benefits / losses)	It is financially cheaper to implement and maintain because is familiar system to available human resources, but provides simplistic cost accounting, hiding unknown benefit or potential to lose.	It is relatively rather expensive to implement and maintain, required qualified human resources, but provides higher cost accounting accuracy, potential to create clear benefits or profits.

Various cost drivers may have been set to serve manufacturing production systems, while specific adjustment is required to adapt to the construction process. Practical hierarchy level of activities is illustrated in table 2.

It intends to visualise the applicability of diverse cost drivers in construction projects, namely:

Table 2: Activity Hierarchy Level and Cost Driver

Activity hierarchy	Cost driver
Unit-level activities	
Material	volume units
Depreciation	time units
Batch-level activities	
Mobilisation	number of mobilisations
Quality inspection	number of inspections
Project-sustaining activities	
General plan	number of engineering hours
Resource planning	number of resource plans
Facility-sustaining activities	
Rental office	square feet

- Unit level is an activity cost driver that assigns costs by the units of output bases, where costs are measured for every unit of output. A good example for unit level includes direct materials, direct labour, and equipment depreciation (Kim and Ballard, 2001).
- Batch level is an activity cost driver that assigns costs by the batches of output group bases, where costs are measured for every batch of outputs, regardless the batch size of products. Selected example for this category includes procurement batch (e.g., purchase order placement, material received, suppliers payment), delivery batch (e.g., material delivery to site), process/task batch (e.g., setup, mobilisation, quality inspection), and hand-off batch (e.g., external quality inspection) (Kim and Ballard, 2001).
- Project-sustaining is an activity cost driver that assigns costs by the particular existence of output bases, where costs are measured for every output

of projects, regardless of the unit and batch numbers of products. A proper example for this driver includes general planning, resource planning, and cost planning (Kim and Ballard, 2001).

- Facility-sustaining is an activity cost driver that assigns costs by the facility employs for output bases. Facility costs normally support the whole project and entire organisation. A fine example for this category is rental offices, general administration costs, and so on (Kim and Ballard, 2001). Those resources are not

directly related to the project activities, but the costs that are assigned by facility-sustaining activity driver will therefore seem to be traceable, e.g., square-footages (Beaulieu and Mickulecky, 2008), and time durations. However, the projects cannot avoid those inevitable overhead costs.

Academic and professional/experts such as Cooper and Kaplan (1988); Kaplan and Cooper (1998); Hicks (1992 and 1999); Kaplan and Anderson (2007); Drury (2008), and others have initially attempted to improve the simplistic traditional costing system for manufacturing companies, but nowadays it has also been extended to serve cost management concerns such as for trading, banking, insurances, healthcares, university, and other service companies including construction industry sectors.

4. Methodology

A literature review enables synthesis and summarises some other authors' ideas on a specific topic to relate with the specific own-objectives. According to Cooper (1988), reviewing the literature' is described as:

"..... a literature review uses as its database reports of primary or original scholarship, and does not report new primary scholarship itself. The primary reports used in the literature may be verbal, but in the vast majority of case reports are written documents. The types of scholarship may be empirical, theoretical, critical/analytic, or methodological in nature. a literature review seeks to describe, summarise, evaluate, clarify and/or integrate the content of primary reports" (Cooper, 1988, pp.104-126, cited in Deakin University, 2010).

Saunders *et al* (2009) did not enumerate a specific structure of a critical review of literatures. This paper is organised methodologically with developing an idea through derives the inventive issues, challenges, seminal works, gaps of knowledge, similar and opposing views from some categorisations of literature' sources such as secondary and tertiary, but yet included no primary evidence. Furthermore, it is presenting a critical discussion and literal findings, conclusion and recommendation in a chronological way.

The following parts of this paper further analyse the background and important aspects of the project overheads, a concept of the underpinning philosophies of the ABC system, a suitable implementation of the ABC system in the construction projects, a conceptual development of the cost controlling model as tools and techniques for the management of project overheads to increase profit during the execution stage in the construction industry. This has been found important to inform further stages and design of the research project.

5. Discussion and Findings

5.1. The Application of the ABC System in the Construction Projects

The ABC system is not new to the construction industry and organisations. The statistic data in the US's industry shows most of the companies (more than 50%) use the ABC system when planning for profit (Daly, 2002). Innes and Mitchell (1995 and 1997) reported that the CIMA administered postal questionnaires to survey the Time-1,000 largest companies in the UK and achieved 439 total responses which involved 21 cross-sector organisations. The result was revealed that large numbers (81%) of the construction and building sectors have considered whether adopting the ABC system, 9.5% have used in the main core of the accounting system, and 9.5% have dropped the system. Kennedy and Affleck-Graves (2001) provide empirical evidence that a performance of the ABC's implication in the competitive markets within the first three years it adoption has significantly increased in both economically and statistically, about 27% above the achievement of non-ABC's companies. Furthermore, the ABC system become a leading contender method to a cost management and process control, that encourages managers to effectively manage construction operations, identify construction cost inefficiencies, and undertake preventive and corrective actions (Marchesan and Formoso, 2001). A corporate culture of construction organisations in project cost management practice would seem to be changed due to the progress of cost accounting and management development. It might be assumed that the requirement of cost accounting reports to satisfy external parties, and could be extended to cover an internal measurement of project activities, construction process, services, and anything that requires informed decision making.

The application of the ABC system in the construction projects will have given powerful cost cause-and-effect relationships to change the role of how personnel ‘think and act’ (SAP AG, 2000).

The dotted horizontal line in figure 2 illustrates the shortcoming of simplistic traditional costing system allocating average overheads on the basis of direct labour, causes a significant problems of cost distortions up to ten times, either over costing or under costing. The curve shows the evidence based on volume of the products and complexity of manufacturing production lines, where the contemporary ABC system is assigning accurate overheads on the basis of diverse cost drivers to avoid hidden losses of cost distortions, and at the same time could create a certain profit.

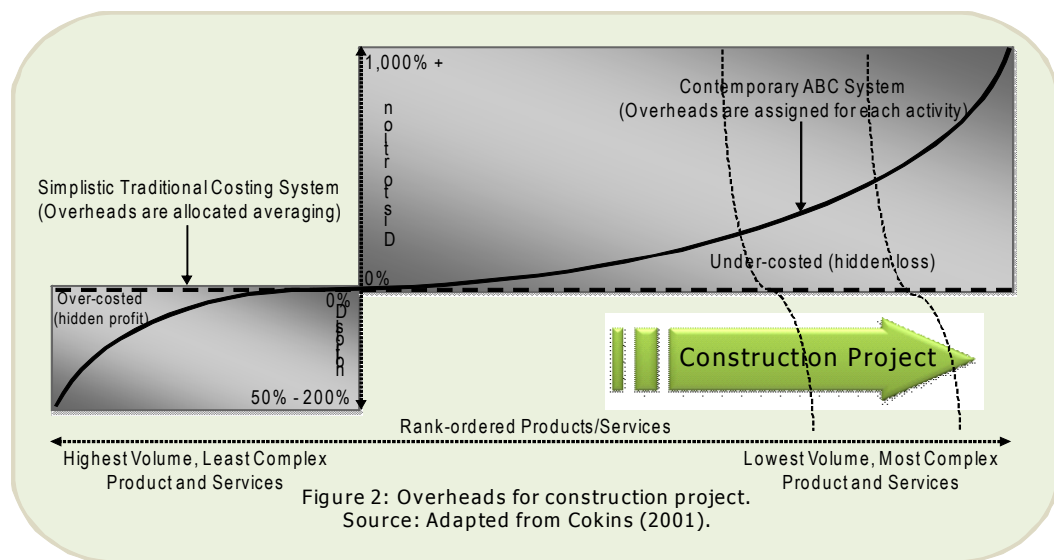

Giammalvo (2007) criticised conventional prorated overheads by contrasting to accurate price calculations when selling green groceries at the retailers, should consider fair overheads per item-sold is identical aspects with per activity-done in construction projects to avoid cost distortions. Cockins (2001) has highlighted averaging overheads caused cost distortions, hiding profit with over-costed overheads up to 200%, or unknown losses with under-costed up to 1,000% based on products or services provided. Construction projects during operations have a similar problem of cost distortions when arbitrarily allocated project overheads on the basis of direct labour. Those project overheads are not clearly defined and have poor relationships

associated to activities. The construction projects nowadays are unique in character and mostly complex in nature (shown in the right side of figure 2). The problem of simplistic traditional costing system causing major cost distortions due to averaging indirect overheads on direct labour cost basis. This might be rectified by implementing the contemporary ABC system with potential to increase profit.

5.2. The Project Cost Controlling Tools and Techniques

A shortcoming of the cost management practice on cost planning and controlling methods, tools and techniques has considered to be the lack of practical knowledge of construction process (Akintoye and Fitzgerald, 2000). Conventional cost accounting management tends for recording, documenting and reporting the spent costs rather than controlling cost expenses and managing changes. It may have caused an inability to satisfy the preferences of the contractors about monitoring project status, updating project expenses, and managing profit changes to the cost planning (as the cost baselines) during the construction operations. Fortune (2006) criticised current methods such as neural networks, neuro-fuzzy networks, sustainability and whole life costs models, and suggested for the requirement of additional investigations whether these formulations of tools and techniques are actually effective in practice. Staub-French and Fischer (2002) developed the ACE-Activity-based Cost Estimating models based on estimator's preferences, product design features, costs, materials and labour, but it was excluded to consider the characteristic of site-projects, the skills of human resources, and the specific project overheads. These would appear that there are some limitations of implementing current methods and the conventional cost management practice.

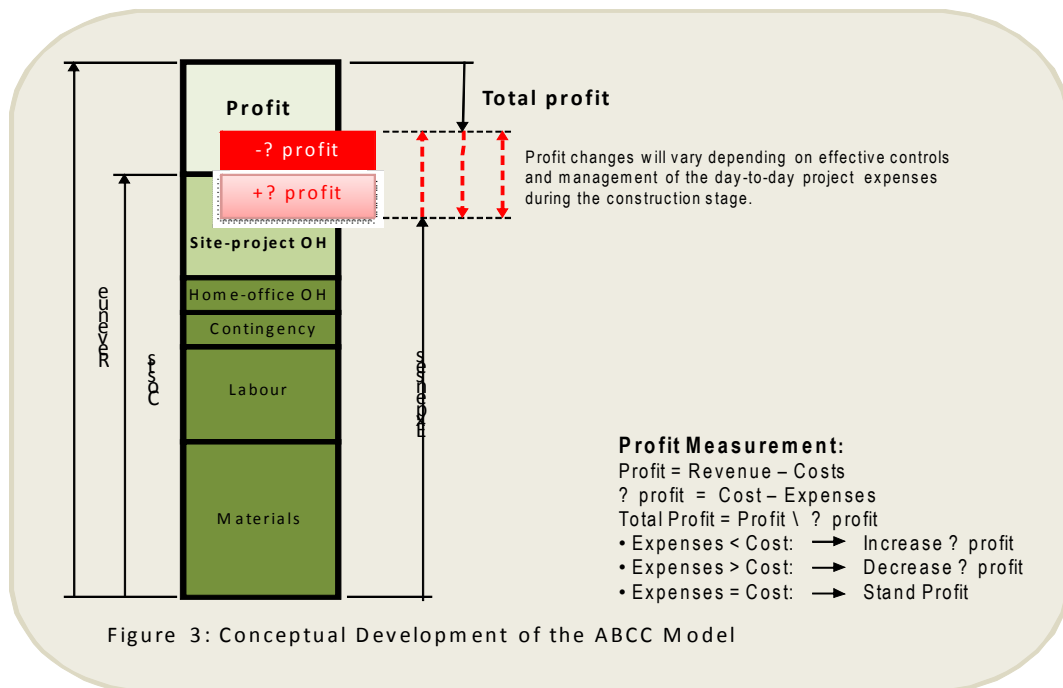

Contractors believe that whichever construction contracts and delivery systems are agreed, the contract prices should cover all construction cost components such as materials, labour, overheads, profit, and contingency (Aretoulis *et al.*, 2006; and Giammalvo, 2007 and 2009). When materials and labour costs are budgeted quite tightly, and to meet competitive global market changes, contingency costs are presumed to be totally utilised to recover project risks, then the overheads may pose the single opportunity to make more profits. The contractors usually prefer to obtain *profit* by planning affordable project *costs*, and endeavour to increase *total profit* by remaining excess *revenue* over smallest possible *expenses*, during construction operations (illustrated in figure 3). The creation of increasing profit through managing project overheads, and controlling profit changes during the construction stage to take preventive or corrective actions are increasingly prioritised. In the real life of project operations, the profit changes will vary subject to successful management and controlling the day-to-day expenditure to complete activities. The ABC system therefore could develop the link (cause-and-effect relationships) between the cost behaviour knowledge of project overheads with practical knowledge of activities, in a particular complexity of construction process of the jobs or project packages, to establish optimum costs and minimum expenses in order to generate maximum profits. The various concerns of the contractors to monitor project status, increase

total profit, and analyse the relationships between expenditures and physical activities during project operations, would seem to be fulfilled with the application of the ABCC concept for the management of project overheads, that are recommended within the project cost controlling functions, which include:

“..... influencing the factors that create changes, ensuring that all change requests are acted, managing the actual change, ensuring that cost expenditures do not exceed the authorised funding, monitoring cost performance to isolate variances, monitoring work performance against fund expenditures, preventing unapproved changes, informing appropriate stakeholders of all approved changes, and acting to bring expected cost overruns within acceptable limits,” (PMI, 2008, pp.179-180).

The critical discussions identified two main dilemmas on developing the ABCC model for the management of project overheads, these are:

- The traditional costing system unclearly defined overheads associated to activities, which requires proper methods to enable assigning the project overheads accurately to every activity.
- The contractor’s preferences about monitoring a status of the projects, updating project expenses, and managing profit changes to the cost planning are unable to be satisfied by the traditional costing system and current costing models, which require better management of project overheads and appropriate cost controlling tools and techniques.

These indicators focus an idea for the research that the ABC system would seem to have a better application than other methods which provide tools and techniques to be able to adapt in creating cost controlling systems. The new ABCC model for the management of project overheads could therefore be investigated and developed through theoretical prepositions, and verified by conducting project case studies that will predict a similar result (direct replications).

6. Conclusion

The project complexity with intricate nature and cyclical business, sophisticated demands for the client's values, diversities and fragmented operations of the constructions require higher investment and advanced technology rather than an intensive labour may increase significantly indirect overheads. The conventional BoQ has been very well established for allocating direct costs, while for further reasons should be concentrated to develop a better method on assigning indirect overheads. It is quite challenging to create complementary contribution for the cost management practice. Cost management, so far, relies on the shortcoming of practical knowledge of the construction process. Percentage addition of overheads are distributed uniformly on direct labour cost basis causes significant cost distortions which has a poor causal relationship to real life of project activities. Unclear definitions of project overheads related activities, company's financial limitations and the lack of accounting knowledge of human resources are becoming the potential barriers of implementing the ABC system, but these challenges would seem to be recovered by the features of the system itself. The logic of the ABC system has proved its' cost driver advantages for the system transparency to cost cause-and-effect relationship and affordable with improved project benefits. Therefore, it should be suggested to be chosen as a robust method, and in the same time criticises the simplistic traditional costing system. Hence, the ABC system holds the potential as a more appropriate tool and technique to enable project operations to be more manageable and controllable with monitoring project costs and expenses. In turn, managing project overheads properly for saving cost expenses should increase the margin of profit during the construction operations.

The previous costing methods required additional investigations to ensure the tools and techniques are proved to be effective in project practices. Development of the ACE model excluded the explicit overheads and the factors of technical practice such as the characteristic of sites and the availability of resources. The recent knowledge can therefore be recommended to extend with a new creation on developing the ABCC model for the management of project overheads to increase profit during construction stage in the construction industry.

7. References

- Akintoye, A., and Fitzgerald, E., 2000. A Survey of Current Cost Estimating Practice in the UK. *Construction Management and Economics*, 18, 161-172.
- Alarcón, L.F., Maturana, S., and Schonherr, I., in: O'Brient, W.J., Formoso, C.T., Vrijhoef, R., and London, K.A., 2009. Benefits of Using E-Marketplace in Construction Companies: A Case Study, in: *Construction Supply Chain Management Handbook*. London: CRC Press, Taylor & Francis Group, LLC.
- Aretoulis, G.N., Angelides, D., Kalfakakou, G.P., Fotiadis, G.S., and Anastasiadis, K.I., 2006. A Prototype System for the Prediction of Final Cost in Construction Project. *Operation Research, an International Journal*, Vol.6, No.3, (2006), pp.323-332.
- Assaf, S.A., Bubshait, A.A., Atiyah, S., Al-Shahri, M., 2001. The Management of Construction Company Overheads Cost. *International Journal of Project Management*, Vol.19 (2001) pp.295-303.
- Atkinson, 2009. Falling Profits at Keller and Travis Perkins. In Edwards, N., *Construction News*, Greater London House, Hampstead Road, London NW1 7EJ, Issues 7129, ISSN 0010-6860 @2009, cncitorial@emap.com.
- Beaulieu, P., and Mikulecky, M. (2008). Inside Activity-Based Cost Systems. *Industrial Management*, Vol.50 (Issue no.3), pp17-21.
- CIOB, 2009. *The Chartered Institute of Building, Code of Estimating Practice*. United Kingdom: Wiley-Blackwell.
- Cokins, G., 2001. *Activity-Based Cost Management, an Executive's Guide*. Canada: John Wiley & Sons, Inc.
- Construction Industry Market Review, 2009. Key Note Publications Ltd, March 2009, Pages: 162, website: http://www.researchandmarkets.com/reportinfo.asp?report_id=834893, viewed: 11-12-2009.
- Cooper, H. M., 1988. The Structure of Knowledge Synthesis. *Knowledge in Society*, Vol.1, pp.104-126, cited in "© Deakin University 2010", website: <http://www.deakin.edu.au/library/findout/research/litrev.php>, this page was last updated on 8th June 2010, last viewed: 15-12-2010.
- Cooper, R., and Kaplan, R.S., 1988. How Cost Accounting Distorts Product Costs. *Management Accounting*; Apr 1988; 69, 10; ABI/INFORM Global, pg. 20-27.

- Daly, J.L., 2002. Pricing for Profitability, Activity-Based Pricing for Competitive Advantage. Canada: John Wiley & Sons, Inc.
- Drury, C., 2008. Management and Cost Accounting. London: South-Western Cengage Learning.
- Enshassi, A., Aziz, A.R.A., and Karriri, A.E., 2008. Investigating the Overhead Costs in Construction Projects in Palestine. Journal of Financial Management of Property and Construction, Vol.13, No.1, pp.35-47.
- Fortune, C., 2006. Process Standardisation and Impact of Professional Judgment on the Formulation of Building Project Budget Price Advice. Construction Management and Economics, 24, pp.1091-1098.
- General UK Statistics, 2007. Construction Economies. CIOB - Membership Statistics, 1st Q 2007. Website: http://www.ciob.org.uk/filegrab/Industry_Statistics.pdf?ref=626, viewed: 7th August 2010.
- Giammalvo, P.D., 2007. Activity Based Costing (ABC) - The Other Side of Earn Value Coin? Published in PM World Today, Vol. IX, Issue V.
- Giammalvo, P.D., 2009. Draft: Pricing vs Costing. ©2009 Paul D. Giammalvo, Donated to AACE Right.
- Giroux, G., 1999. A Short History of Accounting and Business. Web page: <http://acct.tamu.edu/giroux/Shorthistory.html>, viewed: 9 March 2009.
- Gould, F.E., and Joyce, N.E., 2009. Construction Project Management. New Jersey: Pearson Education, Inc.
- Grannof, M.H., Platt, D.E., and Vaysman, I., 2000. Grant Report: Using Activity-Based Costing to Manage more Effectively. Department of Accounting College of Business Administration University of Texas at Austin, The PricewaterhouseCooper Endowment for the Business of government
- Hicks, D.T., 1992. Activity-Based Costing for Small and Mid-sized Business; an Implementation Guide. Canada: John Wiley & Sons, INC.
- Hicks, D.T., 1999. Activity-Based Costing, Making it Work for Small and Mid-sized Companies. Canada: John Wiley & Sons, Inc.
- Innes, J., Mitchell, F., and Yoshikawa, T., 1994. Activity Costing for Engineers. Taunton, Somerset, England: Research Studies Press Ltd.
- Innes, J., and Mitchell, F., 1995. A Survey of Activity Based Costing in the UK's Largest Companies. Management Accounting Research, 1995, Vol.6, pp.137-153.

- Innes, J., and Mitchell, F., 1997. Survey Research on Activity-Based Costing: a Reply to Dugdale and Jones. *Management Accounting Research*, 1997, Vol.8, pp.241-249.
- Innes, J., Mitchell, F., 1998. *A Practical Guide to Activity-Based Costing*. London: Kogan Page Limited.
- Kaplan, R.S., and Cooper, R., 1998. *Cost & Effect Using Integrated Cost Systems to Drive Profitability and Performance*. Boston, Massachusetts: Harvard Business School Press.
- Kaplan, R.S., and Anderson, S.R., 2007. *Time-Driven Activity-Based Costing, A Simple and More Powerful Path to Higher Profits*. Boston, Massachusetts: Harvard Business School Press.
- Kennedy, T., and Affleck-Graves, J., 2001. The Impact of Activity-Based Costing Techniques on Firm Performance. *Journal of Management Accounting Research*, Vol.13, pp.19-45.
- Kim, Y.W., and Ballard, G., 2001. Activity-Based Costing and Its Application to Lean Construction. The proceeding of the 9th annual conference of the International Group for Lean Construction, National University of Singapore.
- Kim, W.Y., and Ballard, G., 2002. Case Study - Overhead Analysis. Proceeding IGLC-10, Aug, 2002, Gramado, Brazil.
- Kim, Y.W., and Ballard, G., 2005. Profit-Point Analysis: A Tool for General Contractors to Measure and Compare Costs of Management Time Expended on Different Subcontractors. *Canadian Journal of Civil Engineering*, 32: pp.712-718.
- Lock, D., 2004. *Project Management in Construction*. Hants, England: Gower Publishing Limited.
- Mansuy, J.E., 2000. Activity-Based Costing Can Improve Project Bidding. *Industrial Management*, COPYRIGHT 2000 Institute of Industrial Engineers, Inc., (IIE).
- Marchesan, P.R.C., and Formoso, C.T., 2001. Cost Management and Production Control for Construction Companies. The proceeding of the 9th annual conference of the International Group for Lean Construction, National University of Singapore.
- Ostwald, P.F., 2001. *Construction Cost Analysis and Estimating*. New Jersey: Prentice Hall.
- PMI, 2008. *A Guide to the Project Management Body of Knowledge (PMBOK Guide)*, Forth Edition. Pennsylvania, USA: Project Management Institute, Inc.
- RICS, 2009. *RICS New Role of Measurement, Order of Cost Estimating and Element Cost Planning*. United Kingdom: @ Royal Institution of Chartered Surveyors (RICS).

RocSearch Ltd., 2006. The UK Construction Industry: An Analysis. RocSearch Ltd, Feb 2006, Pages: 37, website: http://www.researchandmarkets.com/reportinfo.asp?report_id=316909, viewed: 11-12-2009.

SAP AG, 2000. Success Story: SAP Engineering and Construction, Activity Based Costing with R/3 at ABB Industries AG. SAP Headquarter SAP AG: Neorottstr, Germany, www.sap.com, ©2000 by SAP AG. http://www.sap.com/usa/industries/eng_construct/pdf/ABB_costing_update.pdf, viewed: 08/09/2009.

Saunders, M., Lewis, P., and Thornhill, A., 2009. Research Methods for Business Students. Fifth Edition. Essex, England: Pearson Education Limited.

Sears, S.K., Sears, G.A., and Clough, R.H., 2008. Construction Project Management; a Practical Guide to Field Construction Management. New Jersey, Canada: John Wiley & Sons, Inc.

Staub-French, S., and Fischer, M., 2002. Generating and Maintaining Activity-Based Cost Estimates with Feature-Based Product. International Symposium on Automation and Robotics in Construction, 19th (ISARC). Proceedings: National Institute of Standards and Technology, Gaithersburg, Maryland. September 23-25, 2002, pp.287-292.

Sutrisna, M., Potts, K., and Proverbs, D., 2004. Quotation Mechanism for Pre-Pricing Variation in Civil Engineering Projects: a Quest for Best Practice. Journal of Financial Management of Property and Construction, Vol.9, No.1, pp.13-25.

The Scottish Government, 2004. Analysis of Historical Cost Movement in Scottish Social Housing - Final Report. The Scottish Government, Riagaltas na ha-Alba. Website: <http://www.scotland.gov.uk/Publications/2004/06/19127/34792>, viewed: 7th August 2010.

UK Construction Group - UKCG, 2009. Construction in the UK Economy: the Benefit of Investment. UKCG Centre Point, 103 New Oxford Street, London WC1A 1DU. Website: www.ukcg.org.uk, and http://docs.google.com/viewer?a=v&q=cache:vSruglGBv1wJ:www.cbi.org.uk/lekreport+Construction+in+the+uk+economy+October+2009&hl=en&pid=bl&srcid=ADGEEShTAnq7B1M-a3EBqQR6Ozv5hFk4YCbDMveKECgqWqkP-H-5tlfFEpwGyANpVuwpu_d_rFBJtecw7cQbnWm8Ptd-

aHid5XXE98DY3cyAtjdeKvvU5nYO6k4NiDmaBR7zvxPhaeVc&sig=AHIEtbQgx3
nGaeUEYFdXGOKjkbKC-H55jA, viewed: 7th August 2010.

UK Corporate Watch, 2004. UK Construction Industry Overview; A Corporate
Profile. Website: <http://www.corporatewatch.org/?lid=277>, viewed: 07th August 2010.

UK Office for National Statistics, 2009. Labour Market Statistics - September 2009.
Statistical Bulletin, website: <http://www.statistics.gov.uk/pdfdir/lmsuk0909.pdf>.

Walker, A., 2007. Project Management in Construction. Oxford, UK: Blackwell
Publishing, Ltd.

Winch, G.M., 2009. Managing Construction Projects. Oxford, OX4 2DQ, United
Kingdom: Blackwell Science, Ltd.

Exploring the link between organizational learning and sustainable construction project

Alex Opoku and Chris Fortune, *School of the Built Environment, University of Salford*

Abstract

The concept of organisational learning is receiving an increasing amount of attention in construction management research and practice. The importance of organisational learning is its potential impact on the improvement of organisational performance. The construction industry is of high economic significance and its projects have strong environmental and social impacts. There is need for sustainable change in the construction industry and the ability of construction organisations to cope with such change requires organisation learning. However existing organisational learning methods in the industry such as post project review and post occupancy evaluation do not assess the completed project against the triple bottom line, as they focus on technical issues. The general area of investigation in this on-going PhD research is organisational learning and project sustainability in the construction industry. It explores the issues of organisational learning and maturity levels at which construction organisations can deliver sustainable projects. It reviews relevant literature and presents the results from an exploratory pilot study that interviewed experts in the industry to explore the state of the art in practice. The research shows that, there is a need in construction management research to further explore the link between organisational learning and sustainability; little research has been done linking organisational learning and sustainability in the construction industry. The research therefore identifies the need to develop a framework for implementing organisational learning for sustainable project delivery. The paper concludes by setting out a design for further work in this area.

Keywords

Organisational Learning, post project review, post occupancy evaluation, Sustainability.

1. Introduction

There has been an increased interest in organizational learning within the construction industry since the Latham (1994) “constructing the team” and Egan (1998) “rethinking construction” reports. In this current climate of economic volatility and uncertainty, many construction organizations are striving to survive and remain competitive. The construction industry is very important to the UK national economy; however, it is believed to have low productivity and poor performance. The key to company survival and prosperity is organizational learning (Chan *et al.*, 2004); however, the construction industry is perceived to be slow to implement new management and technological approaches as compared to other industries. Barlow and Jashapara (1998) believe that, people involved in construction projects are not given the opportunity to feed the experience they have gained back into future projects. These experiences get lost due to the fragmented nature of the organizational structure of the construction industry. Organizational learning improves organizational performance (Lopez *et al.*, 2005; Kululanga *et al.*, 2001) however construction as a project based industry is facing the problems in embracing organizational learning (Chan *et al.*, 2004)

The relation between sustainable development and the construction industry has become clear, since construction is of high economic significance and has strong environmental and social impacts (Sev, 2009). Implementing sustainability in an organization necessitates organizational learning. It is the key element of any effort to effectively implement sustainable development in organization (Siebenhuner and Anold, 2007) In order to address the triple-bottom line of sustainability, construction organizations have to learn to adapt to environmental changes and economic opportunities, with organizational level learning is the primary vehicle for the achievement of the Brundtland (1987) sustainable development agenda in terms of meeting the needs of current and future generations (Porter, 2008)

This paper explores the link between organizational learning and project sustainability in the construction industry. The first part of the paper reviews literature on organizational learning, organizational maturity, organizational learning methods in construction and sustainability. The second part of the paper presents the research questions, the aim and objectives, and the research design and methodology for the

on-going PhD study. The final part of the paper concludes with the findings of the exploratory pilot study conducted by interviewing experts in the field of sustainability and construction management to explore the state of the art in practice.

2. Literature Review

2.1. Organizational Learning

Organizational learning was defined as “the detection and correction of error” (Argyris and Schon, 1978) cited in (Fuller *et al.*, 2007); however organizational learning needs to go beyond detecting and correcting errors. Organizational learning can be described as a dynamic process of creation, acquisition and integration of knowledge aimed at the development of resources and capabilities that contribute to organizational performance (Lopez *et al.*, 2005). The significance of organizational learning is that it can improve organizational performance. Organizational learning is widely acknowledged as holding the key to companies’ survival and prosperity.

Pemberton *et al.* (2001) pointed out that, organizations develop new knowledge and core competencies in order to gain competitive advantage through organizational learning. Organizational learning is very important for creating and sustaining competitive advantage. Organizational learning is the effective way of making use of past experience and adapting to environmental changes (Berends *et al.*, 2003). It is argued that most successful organizations develop effective learning processes at all levels of their organization. Due to poorly developed or inappropriate knowledge acquisition systems in the construction industry, knowledge and experiences gained by many firms are at the individual level and not at the organizational level (Barlow and Jashapara, 1998) Organizational learning should be a restoration process of changing behaviours to enable an organization to achieve change as well as growth (Murray and Chapman, 2003) Organizational change in the world today is so fast and prevalent that, if organizations fail to keep pace through learning, they will not survive (Chan *et al.*, 2004). Organizations now consider learning as a more critical variable than it used to be, due to the changing nature of work today (Thomas, 2006) Organizations can change beliefs and adjust their regular pattern of behaviour through feedback (Hong, 1999) Learning is described as the process of adjusting behaviour in

response to experience (Law and Chuah, 2004). The ability of organizations to effectively process information and influence various organizational actions is fundamental to the process of organization learning. The construction industry is at the forefront of the sustainable change agenda and the ability of construction organizations to cope with such change requires organizational learning. To succeed in the sustainable development concept, organizations have to engage in learning (Muller and Siebenhuner 2007).

2.2. Organizational Maturity

The ability of an organization to engage in learning is influenced by its level of maturity. Organizational maturity level determines how organizations change and improve over time and incorporate lessons learned (CMU, 1994). A maturity model provides an organization with the support and guidance necessary to evaluate their performance today and identify the next steps forward in realising their capabilities. It shows the extent to which project-based organizations clearly and constantly set out processes that are documented, managed, controlled and continually improved. A mature process passes through an unstable stage to a stable stage, to enjoy improved capability (Cooke-Davies, 2004) Organizations differ in their ability to perform organizational learning processes (Muller and Siebenhuner, 2007). As an organization increases in maturity, it shows more improved results (Cooke-Davies, 2004). A qualitative research carried out by Zedtwitz (2002); based on 27 in-depth interviews with R&D managers to review the role of post project review as a tool for improving organizational learning, proposed a five-level organizational maturity model for evaluating the effectiveness of an organization's processes.

Analogous to Carnegie-Mellon University's maturity model, the five-levels are namely; Initial, Repeatable, Defined, Managed and Optimizing as shown in fig.1 below

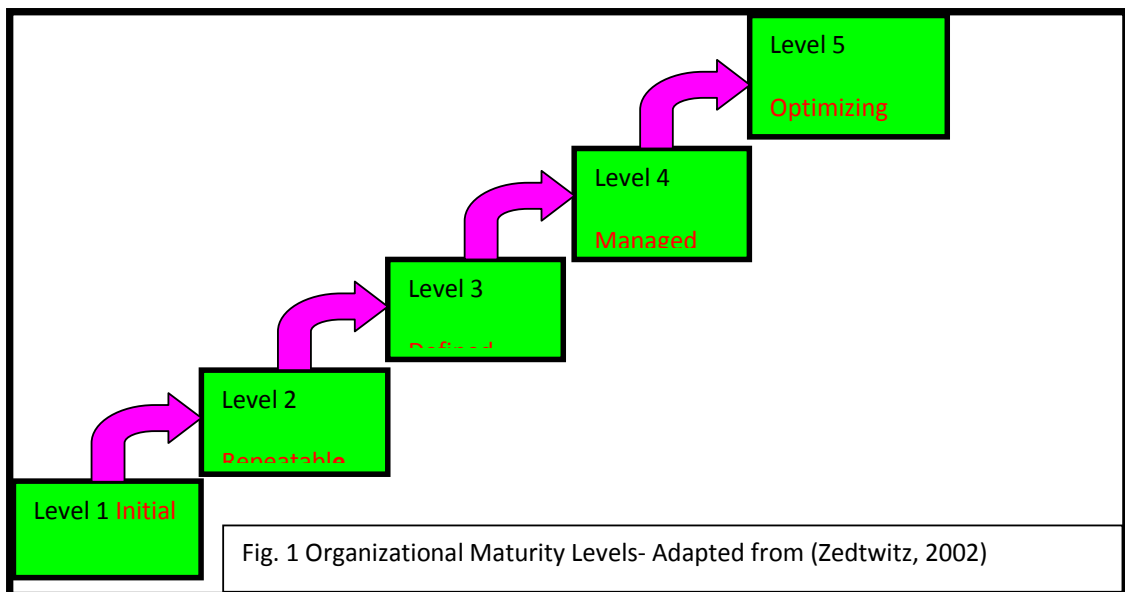

Fig. 1 Organizational Maturity Levels- Adapted from (Zedtwitz, 2002)

2.3. Organizational Learning tools in construction

The construction industry engages in organizational learning through post project reviews (PRR) and post occupancy evaluation (POE). Post project review is one of the most commonly used approaches for passing on previous experience to enhance future project and organizational practice (Zedtwitz, 2002; Cushman and Conford, 2003) Organizational learning involves an organization's ability to reflect on its past experience to modify its future thinking (Chan *et al.*, 2004) The engagement in project reviews and the application of lessons learned provides a mechanism for organizational learning (Kululanga and Kuotcha, 2008)

Lessons learned should be documented and fed back into the organization. Project review is an important organizational learning process. It facilitates continuous learning on all levels within an organization. It is recommended that, a solid post project review practice should be part of a construction organization's learning processes (Zedtwitz, 2002)

Post occupancy evaluation (POE) helps in obtaining feedback on recently completed construction projects from people involved in the construction process, occupants and other end users. However, POE which is very significant in the sustainable process is severely underutilized as sustainability continuous to grow as a priority in the construction industry (Mendler, 2007). Lessons learned from POE can be used to

improve the process and the design of future construction projects. The most important function of POE is to feed forward the learning of lessons obtained from the review of completed projects into future projects (Carthey, 2006)

POE has the potential for supporting “double-looping learning” (Argyris and Schon, 1978); that is to reflect on whether goals need to be reconsidered as well as evaluating how to achieve existing goals better. The use of POE contributes to the reduction of environmental impacts, increased economic viability and high client satisfaction in the construction industry (Kaatz *et al.*, 2006)

Organizational learning methods in the construction industry such as post-project review (PPR) and post-occupancy evaluation (POE) focus on technical issues (OGC, 2007; Zedtwitz, 2002) and do not review completed projects against the triple-bottom line of sustainability; environmental, social and economical impacts.

2.4. Sustainability and Organizational Learning

Sustainable development is rapidly being accepted across the world as the effective way of addressing the social, economic and environmental concerns as shown in figure 2 below. Sustainable development balances environmental resource protection, social progress and economic growth and stability now and for the future.

Sustainable development has been defined in many ways but the most widely accepted definition is:

“Development that meets the needs of the present without compromising the ability of future generations to meet their own needs”- From ‘Our common future’ (The Brundtland Report, 1987)

The construction industry has a significant social responsibility to minimise the damage its projects do to the social environment. Sustainability at the organizational level refers to meeting social and environmental needs in addition to the firm’s profitability (Porter, 2008)

Sustainable construction is the application of sustainable development principles in the construction industry. Sustainable construction aims at reducing the environmental

impact of a building over its entire lifespan, providing safety and comfort to its occupants and at the same time enhancing its economic viability. The construction industry recognises sustainability as a key factor in the success of a project and that performance through the supply chain is, key to this achievement. Sustainability in construction has become a core issue and it is considered as one of the key vehicles for the successful completion of construction projects (Schultman and Sunke, 2007) It is believed that the implementation of sustainability in any organization necessitates organizational learning (Siebenhuner and Anold, 2007) Organizations that ignore and do not turn sustainability issues into competitive advantage are likely to become less effective. Learning and development processes are believed to be an important path towards the sustainable development agenda (Muller and Siebenhuner, 2007)

Construction organizations are required to integrate the concept of social and environmental concerns in the operations; however this can only be achieved through the acquisition of knowledge on the sustainability concept to develop relevant solutions and standards through learning (Muller and Siebenhuner, 2007) Progress towards more sustainable construction requires both government and individual organizations to take action (Holton *et al.*, 2008)

Construction organizations are being urged to learn and engage in new ways of working in order to compete in the current business environment where sustainability is at the heart of the industry (Siriwardena and Kagioglou, 2005). With the increasing demand for sustainable product and services, construction firms should position themselves in order to demonstrate the ability to deliver and tender for works (Cushman *et al.*, 2002)

The Three Spheres of Sustainability

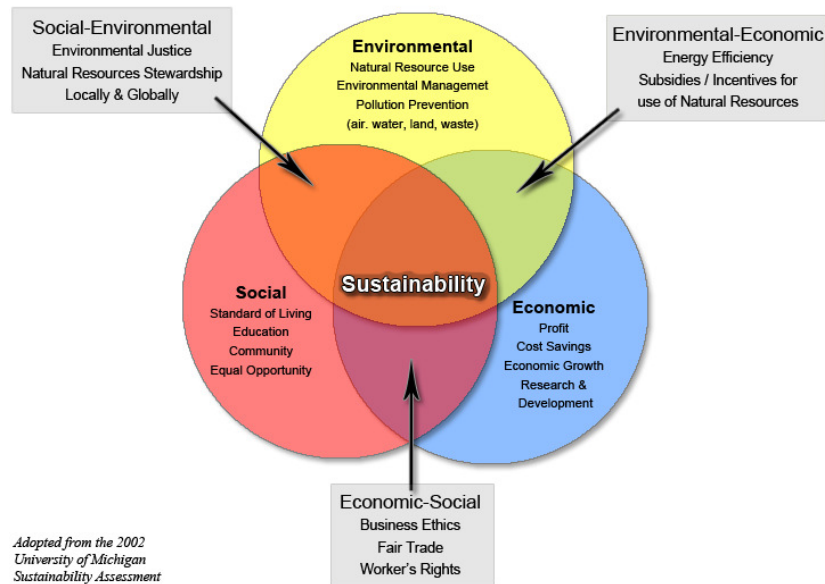

Fig. 2 Three Spheres of sustainability, (Rodriguez *et al.*, 2002)

3. Research questions

The research therefore addresses the following key questions:

- What is organizational learning in construction
- Does the maturity level of an organization influence its learning capacity?
- How can organizational learning promote sustainability in construction?

4. Aim and objectives

The aim of this research is to develop a framework for managing organizational learning for sustainable project delivery by construction organizations at different levels of maturity. The research contributes towards the understanding of organizational learning and sustainable project delivery in construction.

To achieve this research aim, the following specific objectives need to be addressed:

- review the current knowledge on organizational learning in construction

- critically examine the key features of organizational learning methods in construction
- explore the key features of sustainable construction project
- identify and discuss organizational maturity levels for sustainable project delivery in construction
- develop a framework for managing organizational learning in the delivery of sustainable construction.

5. Research design and methodology

This research will adopt a pragmatic philosophical stance. Pragmatism is an epistemological position where one believes that the meaning of an idea or a proposition lies in its observable practical consequences. The pragmatic approach to research involves mixing data collection methods and data analysis procedures. (Creswell, 2003) The research therefore employs both quantitative and qualitative methods that match the specific research questions. Hence the pragmatic paradigm includes tools from both positivist and interpretivist tradition.

Hunt (1991) argues against the use of both qualitative and quantitative methods in the same research, because it is asserted that the two paradigms differ epistemologically and ontologically, However many researchers believe that combining qualitative and quantitative methods (Triangulation) can increase the in-depth understanding of the phenomenon under investigation as well as increase in the credibility of scientific knowledge (Bryman, 2004; Creswell, 2003; Tashakkori and Teddlie, 2003) Triangulation is the combination of two or more methodological approaches, theoretical perspectives, data source and data analysis methods to the study of the same phenomenon. It is a robust and rigorous means of ensuring the use of a mixed method approach.

The first phase of the research is to extensively examine existing literature on organisational learning and sustainability in construction. It will be supported by empirical data drawn from a variety of sources including questionnaires, pilot study, interviews and case study, which will seek respondents from the construction industry in the UK. Questionnaire and interview techniques will be adopted for primary data collection. The motive to use a questionnaire is the ability to reach a large target

group in a practical and efficient way. A pilot study will be used to test the quality, clarity, time scale and bias of the questionnaire (Naoum, 2002) Interviews are useful to obtain detailed information about personal feelings, perceptions and opinions.

The presence of data is an essential part of every empirical research. Data were collected for this paper through an exploratory pilot study; this approach is best used when the research problem to be investigated is at the preliminary stage. A pilot study was conducted by interviewing practitioners in the field to explore the current state of practice in relation to organizational learning, organizational maturity level and sustainable practices in project delivery processes.

6. Data collection and discussion

This exploratory pilot study sets out to explore the state of the art in practice for organizational learning and sustainable project delivery in the construction industry. In this paper, the term pilot study is used to mean a feasibility study or trial run carried out in preparation for the main study. It is a means of gathering primary data to support the suspected research gap in literature.

In addition, a pilot study is undertaken at the early stages of a research study as means of convincing funding bodies, stakeholders and academia that, the proposed research is worth supporting (Teijlingen Van and Hundley, 2001)

This study seeks to engage experts in the field of sustainability and construction management processes to explore the state of the art in practice for organizational learning and sustainable project delivery.

This exploratory pilot study was conducted by interviewing eight (8) practitioners in the field including sustainability managers, visiting professors, sustainability consultants, construction managers etc, drawn from industry and practice with background in contracting, social housing, regeneration, academia and consultancy organisations. The interviews were conducted in a loose structure lasting 15-20 minutes.

The qualitative data collection established the relevance of post project review and post occupancy evaluation in achieving organizational learning in the construction

industry. It was also conducted to explore if sustainability is currently a key criterion in the above learning methods.

The first interview question asked the usefulness of post project review and post occupancy evaluation in achieving organizational learning in the construction industry. It was found that all the interviewees were in agreement that post project review and post project evaluation are very useful for the achievement of organizational learning in construction. As one interviewee put it;

“Very useful, there is a substantial lack of feedback from completed projects to the teams developing the preliminary phases of new projects”

When respondents were asked if sustainability should be considered a key criteria in post project review and post occupancy evaluation, it was found that the interviewees supported the view that, sustainability should be a key criteria in the above construction industry organizational learning methods. However this interviewee commented that;

“Yes, sustainable development is now at the top of the agenda in the industry of the built environment, because this industry uses 40% of the energy used by man and generates 40% of the waste generated by man. It is the key industry to address and engage the improvement of the sustainable presence of man on the planet”

Contrary to the above, some respondents were of the view that, sustainability should be an issue that is only considered at the beginning of the construction process. When probed further, the interviewee responded by saying;

"Sustainability comes at the beginning of the construction process and re-evaluated at the end of completed project"

There were mixed responses when interviewees were asked about the importance of an organization's experience or level of maturity in achieving organizational learning to deliverer sustainable construction projects. Some of the respondents believed strongly that there was a link between organizational maturity or organizational experience and achieving organizational learning to deliver sustainable construction project. One respondent argued that, organizational maturity or experience was important because such organizations will understand better what works and what

doesn't. Other interviewees agreed but indicated uncertainty on how important organizational maturity or experience was in isolation. Some respondents argued that, less mature or less experienced organizations could collaborate with more matured organizations to deliver sustainable construction projects. For instance an interviewee responded as below;

"I'm not certain there is a connection here, there might be. Sustainable project delivery requires improved collaborative work methods and a by-product of working this way is likely to potentially improved organizational learning"

To add to the above, another interviewee simply put it by saying;

"Not very important but some level of organizational maturity or experience is required to fully engage in a meaning learning that will help deliver sustainable construction project"

One significant finding of the study was the impact of leadership on organization's ability to learn and deliver sustainable construction projects. Although leadership was not considered in the initial review of literature and this pilot study, one interviewee said that;

"The role of leadership in sustainability is very essential; organizations need leaders who can champion the sustainable agenda"

Another interviewee added that;

"Organizational maturity level may not work on a linear manner when it comes to learning sustainability; irrespective of the level of maturity, construction organizations need committed leadership to pursue learning that deliver sustainable projects"

Findings from the above data collection and discussion support the need to explore this area of research further, as little has been written on the link between organizational learning and sustainability in the construction industry. These findings are relevant to the study and justify the need to move from exploring the current situation and collect more evidence to actually ascertain the current state of the art.

7. Conclusions

Organizational learning has been identified in the literature reviewed as the key to organizational survival and prosperity. Sustainability is currently at the core of the construction industry's practices because of its high economic significance and strong environmental and social impacts. Sustainability is now a criteria for all UK public sector procurement and a project criteria for all publicly funded housing projects. Construction organizations are required to demonstrate the ability to deliver and tender for works as demand for sustainable services increases.

Organizational learning methods in the construction industry such as post-project review and post-occupancy evaluation focus on technical issues and do not review completed projects against the triple-bottom line of sustainability namely; environmental, social and economical impact. It is argued therefore that, it is essential that construction organisations engage in organizational learning methods to embrace sustainability.

Data from interviews conducted with experts from the field of built environment, support the need to incorporate sustainability into organizational learning methods in the construction industry in order to survive in this current business climate.

Most importantly, the findings have also changed the direction of this research with leadership as a new strand of investigation. It will now examine the impact of leadership on organization's ability to deliver sustainable construction projects irrespective of their level of maturity. This review therefore provides a strong basis for carrying out the proposed on-going PhD research which will attempt to explore the link between organizational learning and sustainability.

8. References

- Argyris, C. and Schon, D. (1978), "*Organizational Learning: A theory of Action Perspective*". Reading MA: Addison Wesley.
- Barlow, J. and Jashapara, A. (1998), Organizational learning and inter-firm partnering in the UK construction industry. "*The Learning Organization*", 5 (2), pp. 86-98.
- Berends, H., Boersma, K. and Weggeman, M. (2003), The Structuration of Organizational Learning. "*Human Relations*," Vol.56 (9), pp. 1035-1056.

Brundtland, G. H. (1987), *Our Common Future: Report of the world Commission in Environment and Development*. Oxford: Oxford University Press.

Bryman, A. (2004), *"Social Research Methods"*, 2nd edition, Oxford: Oxford University Press.

Carnegie Mellon University (CMU), Software Engineering Institute (1994), *"The capability maturity model"*, Upper Saddle River, NJ: Addison Wesley.

Carthey, J. (2006), Post Occupancy Evaluation: Development of a standardised methodology for Australian Health Projects. *"The International Journal of construction Management"*, pp. 57-74.

Chan, P., Cooper, R. Carmichael, S., Tzortzopoulos, P., McDermott, P. and Khalfam, M. M. A. (2004), Does Organizational Learning creates a Learning Organization? Conceptual Challenges from a project perspective. In: Khosrowshahi, F (Ed.) *"20th Annual ARCOM conference"*, 1-3 September 2004, Herriot Watt University. Association of Researchers in construction Management, vol.2, pp. 759-766.

Cooke-Davies, T. J. (2004), Measurement of Organizational Maturity, *"Innovations and Project Management Research"*.

Creswell, J. W. (2003), *"Research Design: Qualitative, Quantitative, and Mixed Methods Approaches"*. 2nd edition, London: Sage.

Cushman, M., Venter, W., Cornford, T. and Mitev, N. (2002), Understanding Sustainability as Knowledge Practice, presented to the *"British Academy of Management conference"*: Fast-Tracking Performance through partnership, London, 9-11 September, 2002.

Cushman, M. and Cornford, T. (2003), Infrastructures for Construction Collaboration: The Cross Organizational learning Approach. *"International Journal of IT in Architecture, Engineering and Construction"*, Vol.1 No.1, pp. 67-78.

Egan, J. (1998), *"Re-thinking Construction: Report of the construction Industry Task Force"*. London: DETR.

Feagin, J, Orum, A and Sjoberg, G (Eds.) (1991) *"A case for case study"*. Chapel Hill, NC: University of North Carolina Press.

Fuller, P.A., Dainty, A. R.J., Thorpe, T. and Slater, I. (2007), Learning Organisations: Can they be shown to exist through the realisation of quantifiable benefits? In: Boyd, D (Ed.), *"23rd Annual ARCOM conference"*, 3-5 September 2007, Belfast, UK, pp. 713-722.

- Hunt, S. D. (1991), Modern "Marketing Theory: Critical Issues in the Philosophy of marketing Science", Cincinnati, OH: South-Western.
- Holton, I., Glass, J. and Price, A. (2008), Developing a Successful Sector Sustainability Strategy: Six Lessons from the UK Construction Product Industry. "*Corporate Social Responsibility and Environmental Management*", 15, pp. 29-42
- Hong, J. (1999), Structuring for organizational learning. "*The Learning Organization*", Vol.6 No.4, pp. 173-185.
- Kaatz, E, Root, D. S, Bowen, P. A. and Hill, R. C. (2006), Advancing key outcomes of sustainability building Assessment. "*Building Research and Information*", 34: 4, pp.308-320.
- Kululanga, G. K. and Kuotcha, W. S. (2008), Measuring Organizational learning through project Reviews. "*Engineering, Construction and Architectural Management*", Vol.15 No.6, pp. 580-595.
- Kululanga, G. K, Edum-Fotwe, F. T. and McCaffer, R. (2001), Measuring construction contractors' organizational learning. "*Building Research and Information*", 29, (1) pp. 21-29.
- Latham, S. M. (1994), Constructing the Team: Report of the government/industry review of procurement and contractual arrangements in the UK construction Industry. London: HMSO.
- Law, K. M. Y. and Chuah, K. B. (2004), Project-based action learning as Learning approach in Learning Organization: the theory and framework. "*Team performance Management*", Vol.10 No.7/8, pp. 178-186.
- Lopez, S. P., Peon, J, M, and Ordas, C. J. V. (2005), Organizational learning as a determining factor in business performance. "*The learning Organization*", Vol. 12 No 3, pp. 227-245.
- Mendler, S. (2007), Thinking inside the Box: The case for post-occupancy Evaluation, *Building Design and Construction* [Online Journal] Available at, <http://www.bdcnetwork.com>, [Accessed on 17/12/2009]
- Muller, M. and Siebenhuner, B. (2007), Policy Instruments for sustainability oriented Organization Learning. "*Business Strategy and the Environment*", 16, pp. 232-245.
- Murray, P. and Chapman, R. (2003), From Continuous Improvement to Organizational Learning: development theory. "*The Learning Organizational*", Vol.10 No.5, pp.272-282.

- Naoum, S. G. (2002), "Dissertation Research and Writing for construction students", Oxford: Butterworth Heinemann.
- OGC (2007), "Improving performance: project Evaluation and Benchmarking", London: OGC.
- Porter, T. B. (2008), Managerial applications of corporate social Responsibility and systems-Thinking for achieving sustainability outcomes. "*Systems Research and Behavioural Science*", 25, pp. 397- 411.
- Pemberton J. D., Stonehouse, G. H. and Yarrow, D. J. (2001), Benchmarking and the Role of Organizational Learning in Developing Competitive Advantage. *Knowledge and Process Management*, Vol. 8 No.2, pp. 123-135.
- Rodriquez, S. I., Roman, M. S., Sturhahn, S. H. and Terry, E. H. (2002), Sustainability Assessment and Reporting for the University of Michigan's Ann Arbor Campus. *University Master's Project, University of Michigan: Ann Arbor: 1-396.*
- Sev, A. (2009), How can the construction industry contribute to sustainable Development? A conceptual framework. "*Sustainable Development*", 17, pp. 161-173.
- Schultman, F. and Sunke, N. (2007), Sustainable management of construction projects. "*CIB world building congress*", construction for development, 14-17 May, 2007, Cape Town, South Africa.
- Siriwardena, M. L. and Kagioglou, M. (2005), An Integrative Review of Organizational Learning Research in Construction, In: Sidwell, A. C. (Ed.) "*COBRA 2005 conference*", 4-8 July 2005, Brisbane, Australia.
- Siebenhuner, B. and Anold, M. (2007), Organizational learning to manage sustainable Development. "*Business strategy and the Environment*" 16, pp. 339-353
- Tashakkori, A. and Teddlie, C. (2003), "Handbook of mixed-methods Research in the social and behavioural sciences", London: Sage.
- Teijlingen Van, E. R. and Hundley, V. (2001), The importance of pilot studies. "*Social Research Update*", Issue 35, UniS (University of surrey)
- Thomas, K. (2006), The learning organization: a meta-analysis of themes in literature. "*The Learning Organization*," Vol. 13 No.2, pp.123-139.
- Zedtwitz, M. V. (2002), Organizational Learning through post-project reviews in R&D. "*R&D management*", 32, (3), pp. 255-268.

Mapping minimal music through the lens of postmodernity

Alexis Paterson, *Cardiff University, Music Department*

Abstract

Musicological histories of minimalism have traditionally been rigidly linear and restrictive. Yet postmodern society engages with culture on an increasingly plural and flexible basis. This article argues that projects such as the New Music Catalogue's 'music map' challenge established definitions of minimalism and, by extension, invite a revision of the way in which musical histories are traced. In addition, recent research into web users' music-related traffic reveals a 'rhizomatic' approach to discovering new music and developing so-called 'networks of taste', reflecting a more general trend that mirrors the aims of the NMC music map. Using the metaphor of a kaleidoscope, the way in which postmodern discourse might inform a non-linear 'mapping' of minimalist developments is examined, and an expansion of the minimalist category is proposed which focuses on internal expansion in preference to a proliferation of new categories.

Keywords:

Twentieth-century music, minimalism, narrative, postmodernity

Mapping minimal music through the lens of postmodernity

Categories—be they stylistic, historical, geographical or social—hold a central place in musicological discourse. Yet twentieth- and twenty-first century musics are diverse and difficult to label for a number of reasons: a recognition that an 'ivory tower' attitude to music dealing only with the masterworks of European and American innovators was elitist and exclusivist; developments in sociology, philosophy, linguistics and critical theory that informed and broadened the horizons of musicological exploration; and what one might call a 'postmodern' attitude to culture (that is, an interest in both sides of the so-called 'high/low' divide, as well as the musics of non-Western cultures). Taking this evidence of a 'postmodern' attitude as

its starting point, this article seeks to explore how such an attitude might inform the categorisation of one particular type of music: minimalism.

Minimalism has, for some decades now, been a term that is both ubiquitous and highly contested. It pervades all aspects of our lives, from interior design; to high-end cuisine; to fashion, art, and music. In music, there is a marked contrast between its popular usage (the simple triads of anodyne advertising, the expansiveness of bands such as Sigur Ros, or the bustling stasis of Philip Glass' film scores), and the musicological rigour of a term where minimal tends to equate to *minimum*: minimal scope, minimal content, and, for its critics, minimal interest. Unsurprisingly, this dual usage causes confusion: the seepage between the everyday and strict confines makes an already elusive term even more difficult to define. The result is often dismissal: a container in which to deposit the banalities of repetitive, tonal, orchestration.¹ Yet there is no need to relinquish the minimal tag to bland commercialism, nor to restrictive readings—designed, no doubt, to maintain certain 'purity' in the face of anything goes easy listening. Instead, it can be shown that minimalism mirrors, and thus elegantly demonstrates, a shift in the twentieth century from modern to postmodern sensibilities, and that with this shift, the way in which minimalism invites categorisation also alters.

In 2006, an article appeared in the *Guardian's* Technology supplement (Webb, 2006), which considered how the internet might have changed the way consumers seek out their recommendations for further listening: contrasting the fanatical record-store enthusiast of Nick Hornby's *High Fidelity* with the proliferation of sites like Myspace, or the recommendation functions embedded in sites such as Amazon. The article was prompted by the publication of a set of results from data-analysts Hitwise Intelligence. The company ran a survey monitoring the music-related traffic of 8.43 million internet users in the UK over the space of one week, tracking 'click flow' (the navigation from one site to another through embedded hyperlinks), to create a picture of what Webb describes as 'the UK's online music ecosystem' (2006, p.2). This 'ecosystem', was made up of social networking sites such as Myspace and Bebo,

¹ An assertion that seems to be supported by the fact that it is common, now, to see comment and analysis of works by those 'threatened' with the minimalist tag that seeks to 'rescue' worthy composers from such associations by proving their affiliation to some other school, such as 'complexity', 'post-minimalism', or 'neo-classicism'.

band's own portals, music retailers, record labels, sites posting lyrics and chords, artists' own websites, live ticketing agencies, and review and news platforms. Hitwise published the data from their survey as a 'network map',² and then provided further breakdowns of the data, including a network map focusing specifically on traffic from Myspace. What the survey illustrates is that the increasing commercialisation of culture—the 'global village'—has encouraged a much more open attitude to new music. In the interests of commercial viability, promoters, record companies and publishers are keen to make associations between their popular, mass-marketable artists and those who are less well-known. The significance of the analysis of Myspace traffic is that it reveals the continued importance of peer recommendation, as links between artists are made through the 'friends' space on each profile. Consumers are using the links *between* different artists to generate their own personal 'networks of taste', so that, rather than choosing to be guided by genre or style labels, the relationships between musics become key.

While 'Western art music' has traditionally been perceived as somewhat remote from this commodification of taste, the implications for musicology are significant. The NMC, or New Music Catalogue, is a label that specialises in the promotion of contemporary British composers, and provides an opportunity to disseminate new works to a much wider audience than might otherwise experience them in a concert setting. The NMC music map, launched in 2010, is an attempt to widen access still further by leading listeners who are already familiar with one composer to similar music that they might also enjoy: functioning as a 'network of taste' across the label. The portal to the map (NMC, 2010) reads: 'TAKE A JOURNEY OF DISCOVERY INTO THE WORLD OF CONTEMPORARY CLASSICAL MUSIC: The Music Map is an interactive tool allowing you to explore the relationships between composers, their influences and their work. Like music itself, these connections can be subjective and those shown here offer a view drawn from within the NMC team'.

² The majority of the data referred to in this article is reproduced in the article by Webb (2006). See also Hopkins (2006).

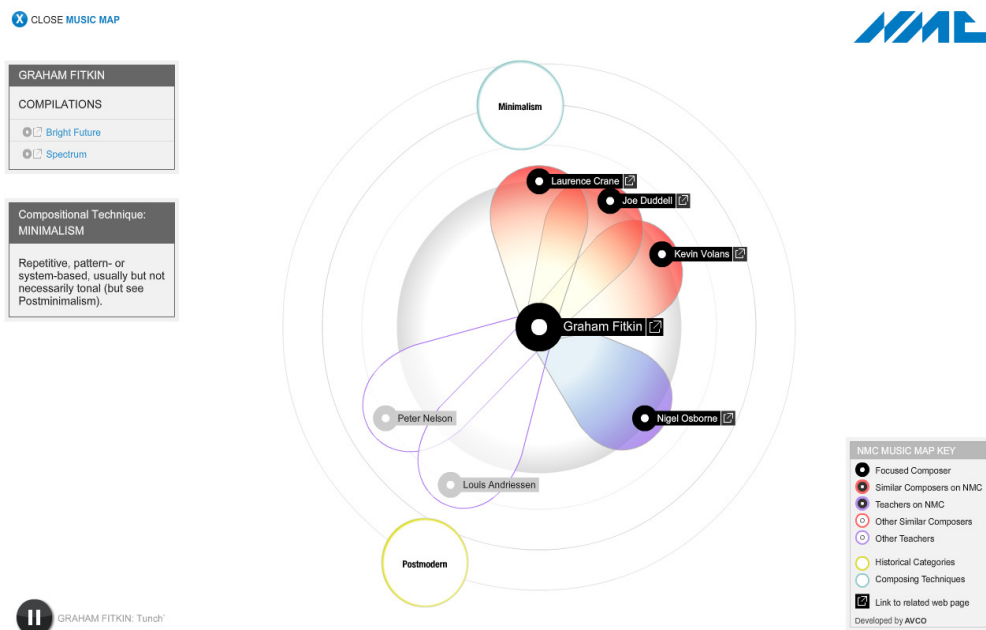

Figure 1: NMC Music Map (NMC, 2010), Graham Fitkin ('postmodern, minimalism')

Selecting a composer's name gains entry to the map (see fig. 1), where a list of available recordings and an audio sample on the left immediately reveal the map's commercial function. In the centre, the composer's name is surrounded by red radials indicating 'similar-sounding' composers, and blue radials indicating teachers.³ The outer two circles contain category bubbles, and definitions can be read by hovering over them (minimalism is shown). The outermost circle contains what NMC calls 'historical categories' and the circle below contains 'composing techniques'.

To navigate the map, any of the composers in the radials can be clicked, and their own nucleus will move to the centre while the previous one moves to the side, with repeated moves generating a series of connections:

³ These radials lie on two levels, and the immediate impression is that the inner circle represents close relationships and the next ring more abstract, or less significant, connections. In fact, the closer circle includes any composer who appears on an NMC recording, while others lie at the further circumference: a reminder of the commercial function of this map.

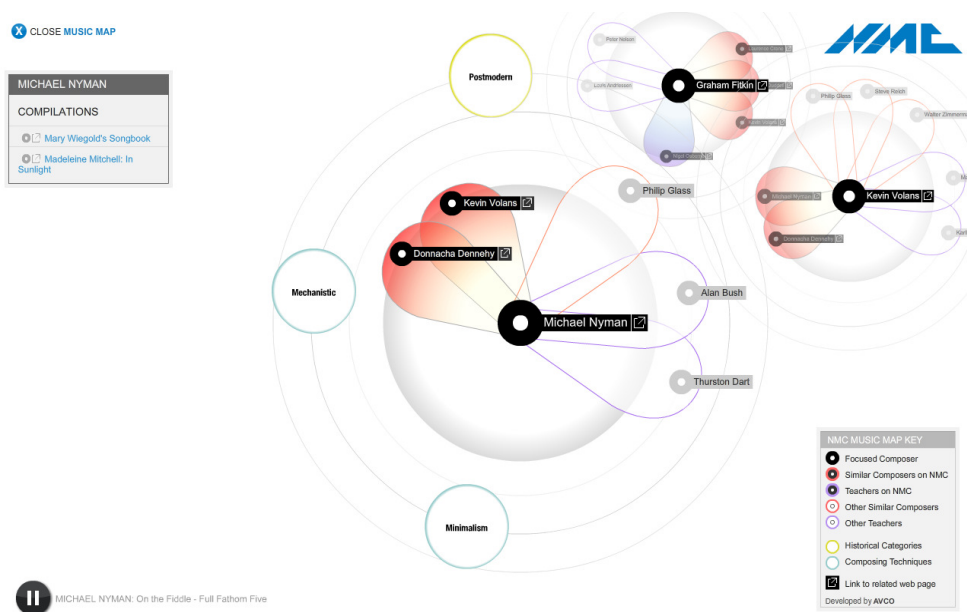

Figure 2: NMC Music Map (NMC, 2010), Grahams Fitkin > Kevin Volans > Michael Nyman

All of the composers shown in Figure 2 are described as ‘minimalist’ and the image suggests a web of connections being built between these composers. However, this implicit interconnectedness is actually restricted: while all three of the composers on this screen are listed as minimalist, Nyman and Fitkin do not appear on the radials as composers related to one another. NMC is careful to point out the subjectivity of these categories, yet the fact that all three of these composers can be labelled minimalist while at the same time not be considered equally ‘related’ suggests a flexibility in the category ‘minimalism’. Significantly, no search of the music map can be made using any historical or technical categories: navigation is focused on connection *between* composers rather than fulfilment of any preferred stylistic checklist. This fact leads one to raise the question of how the category minimalism functions. For the NMC, where the music map acts as a promotional tool, their categories should be access points to the music.⁴ NMC describes minimalist technique as ‘repetitive, pattern- or system-based, usually but not necessarily tonal’, which coheres in many respects with

⁴ Research at De Montford University (Weale, 2006) has shown that SHF’s, or ‘something-to-hold-onto’ factors, such as information that guides you through the music, an evocative title, or an explanation of the composer’s intention, generate far more positive responses to a piece than if the listener encounters it ‘cold’. In marketing, the labels that are applied to music function in a similar way, whether as the style and genre markers in a record store, the column headers in a reviews section, or as the music map’s category descriptions.

standard musicological definition. However, this definition lacks the limits that would be prescribed by musicology: for example, J.S. Bach's *Well-Tempered Klavier* is both repetitive and pattern-based, but not minimalist. Minimalism is also characterised by lengthy durations; abstract, non-programmatic content; almost imperceptible changes in the relationships between different instruments, textures and harmonies, and, crucially, a 'strict' definition of minimalism would emphasise that the logic behind these patterns is always *audible*.⁵ However, this 'strict' definition would only apply to a limited number of pieces, dating mostly from the sixties and seventies.

If one listens to the audio excerpts that accompany the NMC's minimalists, it becomes clear that the tag covers a diverse range of sounds.⁶ Yet conventional musicology would dismiss almost all of them from the strict category of minimalism: some would exclude Rzewski because of the political rhetoric that accompanies his music; many would say that the music Reich wrote after 1976 is more 'post-minimalist', since while the aural impression is similar, the logic of the processes is more difficult to work out. Nyman and Adams are also more commonly called post-minimalist because they mix a minimalist soundscape with baroque and romantic forms respectively (both display a postmodern *attitude* to minimalism, where a former orthodoxy is transformed into a 'code' that retains repeated patterns and driving rhythms, while combining these with the markers of other styles). David Lang, with his much 'rockier' sound, is generally referred to as a Totalist, while Fitkin and Martland, who both formed band-like ensembles to perform their music, are recognised as emerging from a minimalist tradition, yet having very much moved beyond it to some form of synthesis with popular music influences. The remainder are rarely discussed in relation to minimalism. In contrast to the NMC, musicologists' readings of minimalism are much more restrictive. So ingrained are these restrictive

⁵ Audible process should be understood as the ability to discern a rule or rules that have governed every element of change within a piece, if it were listened to from the start. A good example of this would be Steve Reich's *Clapping Music*, where a single rhythmic cell is clapped by two players. The second player gradually claps 'out of phase' with the first to generate gradually shifting changes in the interlocking rhythms of the two performers. The piece is complete when the second player has gone 'full circle' and once again synchronises with the first performer.

⁶ To hear musical examples of the composers the NMC lists as minimalist, go to the screens of Oscar Bettison, Lawrence Crane, Rolf Hind, Michael Nyman, Kevin Volans, Walter Zimmerman, John Adams, Graham Fitkin, David Lang, Steve Martland, Steve Reich, and Frederic Rzewski (NMC, 2010).

readings that the phrase 'high priests of minimalism' is commonly understood as a shorthand for the music of La Monte Young, Terry Riley, Steve Reich, and Philip Glass: an insuperable quartet of originators that dominate all discussions of minimalism. On listening to the early works of these composers, a much more consistent sound can be discerned: the processes governing the unfolding of a piece are easily understood; the aural impression is one of barely varying uniformity in volume, timbre, and mood. Yet there are also some significant differences. Young's *Drift Studies*, for example, present a single, unvarying sine tone: a very pure, static manifestation of minimalism that was short lived. By contrast, the other three 'high priests' create a similar static impression, but through the unvarying repetition of more dynamic, rhythmically driven cells. In addition, Reich works predominantly with tape and a 'phase shifting' technique in these early years, while Riley incorporates an improvisatory element into his music. Given these contrasts, it appears that the reasons for the categorical rigidity that binds these composers together is threefold: geographical, rhetorical, and genealogical.

Geographically, all four composers are American and all have connections, in various ways, with the dynamic downtown New York scene of the sixties and seventies. Even when operating outside New York, for example when Terry Riley gives *In C's* premiere in San Francisco (1964), pairings amongst the four occur (in this instance, with Reich performing in the premiere, and claiming to have come up with the constant piano pulse which now characterises the work). This sense of common location is reinforced by the composers' own rhetoric. All stress the distance between the free creativity of downtown New York and the 'uptown' establishment's high modernist principles: utilising urban geography to reinforce a sense of political and aesthetic separation (despite the fact that all four were students of this 'regime').

However, there are many composers who shared the high priests' aesthetic aims, worked alongside them, and who are missing from the minimalist story. One might suggest that the reason they are now seen as the core originators is due to their commercial success: an ironic suggestion given that while musicology retains some hostility to minimalism because of its simplicity and accessibility, the story of minimalism seems to have become 'minimalised' by measures of popularity. In addition, a rhetorical alignment between minimal music and the visual arts has led to a somewhat 'time-locked' definition. Edward Strickland, who charts the development

of minimalism across all art-forms, identifies the first minimal works as Barnett Newman's *Onement* series of paintings (begun in 1948), but does not identify the first piece of minimalist music for another ten years (La Monte Young's *Trio for Strings*) (Strickland, 1993). The connection with the visual arts is not surprising; numerous examples from the history of music demonstrate the tendency to look for corollaries between these two media. Early performances in art galleries and the close working relationship between, for example, Philip Glass and Richard Serra are obvious suggestions of some aesthetic common ground. In addition, the absence of many theoretically illuminating statements by these composers leads commentators, (unsurprisingly when faced with the blank abstraction of early minimalist compositions), to the art criticism of writers such as Alloway and Krauss in order to explain the underlying aesthetics of the music. However, while musicology has retained minimalism as a term that covers at least two decades of composition, the visual arts swiftly renamed subsequent developments: while still used to designate a generally pared down aesthetic, subtleties *within* the term are revealed, as each subsequent show of new works attracted new titles. This continuity through reinvention is absent from the rigidity of the musicological use of minimalism, yet the idea of expansion from *within* a term is a useful one.

Finally, musicology demonstrates a desire to create narratives that follow a genealogical logic. The story of minimalism has become so indelibly linked to these four composers that even if one seeks to explore the boundaries of minimalist development, the necessity of engaging with existing discourse continues to reinforce the linear narratives that are already in place. In addition, the 'history' of minimalism, as it stands, is rigidly linear, tracing only 'progression' rather than diversification. Take, for example, these extracts from one of only four monographs on minimal music, where the repetition of minimalism seems to seep into musicologist Keith Potter's commentary. First, Potter (2000, p.245) says of Reich:

if the consolidation of sonic impact and putative harmonic motion already redefines the minimalism of *Music for Mallet Instruments, Voices and Organ*, its successor's extensions of these render *Music for 18 Musicians* more clearly "post-minimalist".

Followed by something almost identical of Glass (2000, p.323):

if the consolidation of sonic impact and the concomitant concern with texture and psycho-acoustics already redefines the minimalism of *Music with Changing Parts*, its successor's extension and clarification of these render *Music in 12 Parts* more clearly "post-minimalist".

Although an extreme example, these extracts demonstrate an attempt to construct a genealogy of minimalism by shoehorning compositional development into a repeating pattern. While common ground existed between these composers during the sixties and early seventies, their paths diverge to such an extent that the implication of simultaneous development in these two statements is misleading.

So how might these two forms of categorisation—the 'maximal' minimalism of the NMC and the 'minimised' minimalism of musicology—be synthesised? As mentioned before, in the visual arts minimalism has both a specific and broad application, with a multitude of relationships *within* the umbrella of the label. By recognising that the ubiquity of the 'minimalism' tag is ingrained in contemporary rhetoric, we can begin to expand the internal boundaries of the category by exploring interrelationships between certain characteristic features. By drawing on the implications of Hitwise's networks, and the possibilities of NMC's music map, subtle differences and detail might permeate the boundaries of strict definition. What both these ventures show, is that while music histories are traditionally recounted in a linear fashion, modern patterns of musical consumption (and, by extension, ways of *thinking* about musical relationships) are more flexible, and less grounded in concrete developmental relationships. In addition, methods of production have become central concerns in postmodernity. All things extra-musical: marketing, reviews, performance venues, titles of pieces and their descriptions, have a bearing on how music is understood. Yet musicology often focuses on analysis: picking apart the mechanics of a piece of music with the use of a score. What the foregrounding of production—the pragmatics of cultural experience—demands, is that musicology considers how this music functions to the 'naked ear'.

The flexibility of connecting characteristics must also be acknowledged alongside the linear narratives of musical development. As Deleuze and Guattari (2004, p.6) might put it, a minimised minimalism operates within an arboric structure, 'the binary logic of dichotomy'. By contrast, maximal minimalism, and the networks under discussion,

are rhizomatic: connections are made through ‘lines of flight’ and the realisation of possibilities of likeness. Furthermore, the globalisation of culture and the commercialisation of heritage makes physical proximity (and hence, geographical restriction) less relevant to a listener even though it may still be part of the local narrative of composers’ individual stories. In a rhizomatic, networked conception of minimalism, relationships between musics are flexible and dynamic, and this facet of the label should be weighed against the tendency to seek out genealogies of influence and development. Instead we might recognise that relationships between composers appear, disappear, and alter throughout the course of a career.

Indeed, the individual, local narrative is key: what the music map fails to address, and musicology often tries to make too uniform, is the tendency of composers to adapt, develop and change direction. Similarly, listeners will come to this music from various vantage points: some from a traditional music background after hearing a short piece at a concert; some via a film soundtrack or advertisement; some through a namecheck from a popular musician; others because of associations with the visual arts. There are of course contradictions between an abstract compositional method and the resultant music’s use in various emotive settings (such as film scores or advertisements) but it should also be clear that no works will ever conform to a ‘perfect’ conception of minimalism. Musicology should explore the margins of difference as these various avenues lead to different ways of receiving and understanding this music; and a postmodern understanding of cultural consumption demands that the multiple modes of engaging with this music might alter the way in which the label is perceived and understood.

What remains are characteristics that dominate minimal music, but exist both within and without the ‘strict’ category. So, for example, instead of drawing a division between the contemporaneous use of audible process in America and identifiable ‘systems’ in the UK, we can see the common ground between, for example, Reich’s gradual process and White’s machine music. Similarly, the sparse piano music of Howard Skempton (British) throws up so similar a soundworld to Terry Jennings’ (American) work of the early sixties (which in turn further minimises the ideas of Young’s *Trio*), that to draw geographical exclusion zones seems arbitrary. Minimalism has become a plural category that thrives on synthesis with other styles. Through this transition, minimalism undergoes a conversion into one of the most

adopted and adapted codes available, and methods must be sought which measure and describe this synthesis, rather than simply dismissing music for failing to be ‘pure’ or ‘strict’ minimalism which conforms to some form of stylistic checklist.

I would suggest that early minimalism—both the type that focuses on pure reduction (such as Young’s *Drift Studies*), and relentless repetition of constant, dense textures (as in Glass’ *Music in Changing Parts*)—represents a remnant of high modernist principles of innovation and progression. While Young’s *Trio* is generally heralded as the earliest minimal example, it still follows (albeit minimised) serial compositional principles. Here, it is the *aesthetic* of minimalism that occupies the foreground: dogmatic adherence to rigorous constraints is its principal concern. But minimalism transforms through the sixties to the point where, between around 1968 and 1976, a more stylistically homogenous sound emerges—what you might call minimalism with a capital ‘M’ (Krauss, 1991, p. 123). From the release of the first recording of *In C* (1968) to the premiere of *Music for Eighteen Musicians* (1976), critical attention to minimalism grows. And so the minimal tag becomes necessary in order to define a critically and commercially viable style. This capital-M’d minimalism has audible process, limited harmonic progression, extended duration and repetition, and homogenous texture.

However, many of these aural effects continue beyond *Music for 18*, while audible process is gradually obscured. What if these early examples are accorded almost etude-like status? Then, minimalism mirrors and articulates a rupture with modernist demands for stylistic and theoretical unity. Reflecting an emerging postmodernity, this ‘dogmatic’ minimalism becomes postmodern ‘code’: orthodoxy becomes one possibility amongst *orthodoxies*. Thus, minimalism becomes flexible: process and repetition remain central, but there are also those who engage critically with these codes. Dutch composer Louis Andriessen is one example of a composer who engages dialectically with the boundaries of a minimal code (with his chromaticism, brash timbres, and diverse quotations), yet retains a sense of single-minded repetition.

The idea of development—of *progress*—is so dominant in our depictions of musical history that linearity cannot help but become a feature. But postmodern attitudes to creative practices focus on refreshment, renewal, and *recreation*, as much as they do advancement: a critical engagement with the cultural impact of the postmodern

condition can result in works that challenge the methods of minimalism from the *inside*. Boundaries are challenged, yet these works remain essentially minimalist. For this reason, I seek to propose a metaphor for a maximal minimalism that recalls the structure of the NMC music map: that of the kaleidoscope. While the identification of developments has always driven accounts of musical history, to attempt such a survey of minimalism is paradoxical: the advancement of minimisation proves to be moving in the opposite—maximal—direction. Minimalism is no pure style or historical movement. Instead, minimalism should be understood as a tag that provides a starting point: not into a plethora of associated categories that are excluded from minimalism, but a diversification from the inside out.

The rhizomatic attitude we find in the music map invites us to explore connections, and such connections can point towards new musicological approaches. Indeed, studies such as those outlined at the start of this article should demand an engagement by musicologists with ‘real-life’ modes of musical consumption and categorisation if musicology is to retain its relevance to the increasingly diversified musics of the twentieth- and twenty-first centuries. As a single strand of this diversity, imagine each feature of minimalism: duration; stasis; process; repetition, and so forth, as myriad pieces of a kaleidoscope. With each new formation, each rebalancing of relationships, the picture changes; different patterns and different connections emerge. Like a kaleidoscope, our boundaries are clear: but the contents are in flux, the relationships dynamic, and the connections between works, composers, and influences constantly revealing themselves in new and interesting ways. Minimalism, as the NMC music map shows, has been accepted as—*is*—a diverse category. The music map hints at possibilities for reimagining the way in which we depict musical relationships, revealing that, as Deleuze (2004, p.13) says, ‘the rhizome is altogether different, *a map and not a tracing*’. Categorisations of minimalism need not be rigid, restricted, or minimised by traditional linear logic. Explanations of minimalism can play upon associations and revel in its postmodern transformation: revealing this music as detailed, diverse, and kaleidoscopic.

References

- Deleuze, Gilles and Guattari, Félix, 2004. *A Thousand Plateaus: Capitalism and Schizophrenia*. Translated by Brian Massumi. London: Continuum.
- Hopkins, Heather, 2006. Bebo and MySpace Network Maps for Music Category. Hitwise Intelligence, [Weblog] 30 Nov. Available at: <http://weblogs.hitwise.com/heather-hopkins/2006/11/bebo_and_myspace_network_maps.html> [Accessed 12 May 2010].
- Krauss, Rosalind, 1991. Overcoming the Limits of Matter: On Revising Minimalism. In John Elderfield ed. 1991. *American Art of the 1960s*. New York: The Museum of Modern Art. pp. 122–141.
- New Music Catalogue, 2010. *NMC music map*. [Website] Available at: <<http://www.nmcrec.co.uk/musicmap>> [Accessed 15 July 2010].
- Potter, Keith, 2000. *Four Musical Minimalists: La Monte Young, Terry Riley, Steve Reich and Philip Glass*. Cambridge: CUP.
- Strickland, Edward, 1993. *Minimalism: Origins*. Bloomington and Indianapolis: Indiana University Press.
- Weale, Rob, 2006. Discovering How Accessible Electroacoustic Music Can Be: the Intention/Reception Project. *Organised Sound*, 11(2), pp.189–200.
- Webb, Adam, 2006. How to get music to our ears. *Guardian*, 14 Dec. Technology Supplement. pp.1–2.

Risk assessment in natural hazard areas for the resettlement programmes

Panitp Piyatadsananon, Dilanthi Amaratunga and Kaushal Keraminiyage

School of Built Environment, University of Salford

Abstract

Risk assessment has been widely implemented in natural hazard zones in order to identify risk levels in disaster prone areas. This assessment is done by estimating loss and damages from disaster events. This method is essential to indicate the loss and damages required in the emergency assistances. On the other hand, risk assessment is estimated by forecasting from triggering factors causing those disaster events in vulnerable hazard areas. A product of this method is a risk map illustrating all risk levels in potential hazard areas. This map is a useful tool implemented in the disaster prevention plan. Risk map has been produced in various scales such as regional, medium and local scale in responding with the resolution of based maps from the remote sensing images and the available geospatial data. The application of Geographical Information System (GIS) provides an effective way to analyse the risk assessment. These techniques are vital to study several activities in disaster managements. As well as the resettlement programmes, they have been studied and examined by applying these techniques efficiently. Nevertheless, those instances are found in most regional and medium scales. While a successful resettlement management, generally requires a finer scale for a better management in local scale. Therefore, the aims of this study are to provide the basic information and methods of risk assessment in natural hazard areas and to present the feasibility to apply the remote sensing image & GIS techniques in resettlement programmes.

Key words:

Risk assessment, vulnerable hazard areas, risk map, remote sensing image, Geographical Information System

1. Introduction

Natural disasters have occurred to many parts of the world. It is alleged that global warming has enhanced several severe disaster occurrences around the world. Literately, the global warming issues have been initially agonised since the green house effect was found in 1824. This phenomenon boosts ocean temperatures which are forming several terrible storms in these recent decades (World Almanac, 2000). As the result, the hazard areas and disaster prone areas are dramatically spreading throughout the world. A huge number of suffered and died people from disasters challenges researchers to reveal and understand the characteristic of those disasters, as well as to manage all relevant plans to protect people lives and mitigate their sufferings.

Risk assessment is an essential method implemented to estimate the losses and damages of lives and construction in potential hazard areas. It can be done by assessing the data from either pre- or post-disaster events. This assessment is a crucial tool for several kinds of disaster management. It is assessed differently from considered factors and damaged elements. Plenty of risk and hazard maps are produced at regional scale (e.g. He and Beighley, 2007; Nakano et al., 1974: pp.231-243) and at medium scale (e.g. Pande, 2006: pp.598-607; Perotto-Baldiviezo et al., 2004: pp.165-176; Remondo et al., 2006: pp.496 - 507; Sauchyn and Trench, 1978: pp.735-741; Varnes, 1984), nevertheless, there are small numbers of risk and hazard maps produced at local scale (e.g. Schulz, 2004: pp.1-11; Rufin-Soler et al., 2008: pp.195-211). In particular the resettlement activity in hazard areas, it requires risk maps at local scale for the sustainable management.

Resettlement programme is an approach that has been undertaken by many countries as a means of relieving the problem of poverty, unemployment, population pressure, land shortage, disaster mitigation, and famine. It involves with several tasks organised by many organisations. This programme consists of many sophisticate modules; therefore, the visual resettlement plan is required to accomplish these activities. Due to people have inherent social, economical, cultural, psychological and spiritual ties with their environment of origin (Dubie, 2005: pp.131). For this reason, physical and social aspects are both considered in several resettlement programmes.

In order to achieve the sustainable resettlement programme, risk map at the local scale is proposed in this study. This study also provides the information and discussion of the feasibility of the application of the advanced technology response to the resettlement programme. A sustainable resettlement programme based on large scale risk maps is presented showing a framework of the further study. This study is an initial part of a research associated with the application of spatial analysis in resettlement programmes. This study is beneficial to all relevant organisations which implement these risk maps with resettlement programme.

2. Risk assessments

Risk assessments are widely estimated in various disciplines. Focusing on the natural disasters, risk is defined as a product of three major elements: exposure to hazards, the frequency or severity of the hazard and the vulnerability. As well as WMO (1999) defined risk as the product of hazard and vulnerability. Birkmann (2007: pp.20-31) concluded a clear definition of risk assessment as “a survey of a real or potential disaster to estimate the actual or expected damage of lives, persons, injured, property damaged, and economic activity disrupted”. Therefore, risk is a general relationship between hazard and vulnerability as a following equation (Brooks et al., 2005: pp.151-163).

$$\text{Risk} = \text{Hazard} \times \text{Vulnerability} \dots\dots\dots\text{Eq. 1}$$

Hazard assessment is a general method assessing the likelihood and intensity of the natural disaster (Karimi and Hüllermeire, 2007: pp.987-999). Hazard is measured by using a prior statistical analysis of disaster behaviour during a period of time (Remondo et al., 2006: pp.496 - 507). On the other hand, vulnerability is a key issue in understanding disaster risk. Vulnerability can be assessed by comparing the value of damage with the actual value of the element at risk in Eq. 2 (Remondo et al., 2006: pp.496 - 507).

$$\text{Vulnerability} = \frac{\text{Loss of the element due to a landslide of a given type and magnitude}}{\text{Value of the element}} \dots\dots\dots\text{Eq.2}$$

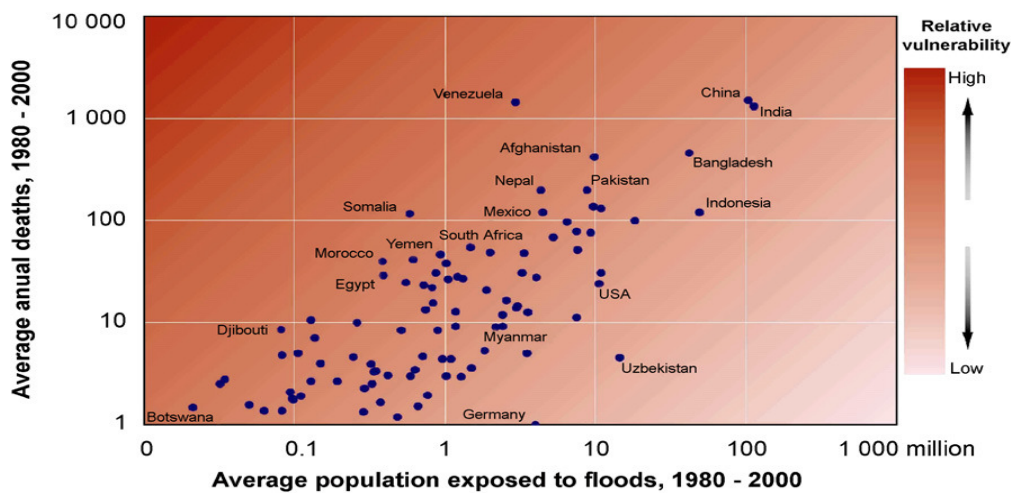

Fig1: Relative vulnerability for flooding, 1980–2000.

Source: EM-DAT OFDA/CRED and UNEP/GRID-Geneva (in UNDP (United Nations Development Programme), 2004)

Some parameters beyond the physical fragility have been focused in assessing the vulnerability since the 80s. Considering to the chart (Fig1), numbers of deaths and the average population exposed to floods from 1980 to 2000 were assessed in relative vulnerability. This is one of the primary parameters considered in assessing vulnerability in hazard areas. Vulnerability was determined by physical, social, economic and environmental factors or processes which increase the susceptibility of a community to the impact of hazards” (UN/ISDR (United Nations International Strategy for Disaster Reduction), 2004).

The data from both pre- and post-disaster events are considered in risk assessments to provide some significant information for furthering all essential tasks. Based on these analyses, several emergency supports can be processed associated with the risk assessment from post-disaster events. As well as the prevention plans, the data from pre-disaster events are essential to these tasks. A traditional way of risk assessment after disaster events has been conducted by the UNDP (2004). This approach provides a result of the calculations as the relative vulnerability. The relative vulnerability was proposed by considering the number of dead people by the number of people exposed to hazards (Fig1) (UNDP (United Nations Development Programme), 2004). Alternatively, relative vulnerability can be assessed by considering the losses of GDP per unit area (Pelling, 2004). As a series of the studies of Cardona, vulnerability

indices were produced and developed based on the vulnerability analysis by considering more than 50 indicators and widely applied in 12 countries in Latin American and Caribbean (Cardona et al., 2004; Cardona, 2005; Cardona, 2006). Additionally, mapping techniques and Geographic Information System (GIS) are implemented to generate the vulnerable landslide areas by developing susceptibility model from statistical relationships between past landslides and terrain parameters related to instability (Remondo et al., 2006: pp.496 - 507). These techniques provide an illustration of disaster locations associated with statistical analysis for a better understanding which is beneficial to any mitigation plans.

Predicting disaster risk requires many involving factors triggering the potential disaster events in hazard areas. There are several techniques assessing risk before the disaster occurrence based on either the empirical data or probability. For instance, fuzzy probability was estimated from possibility and probability distributions. For this reason, the recorded data of disaster events in a hazard area is the significant data assessed in this method. This method is one of the reliable approaches to assess the risk in potential hazard areas (e.g. Karimi et al., 2005: pp.371-384). A relationship between magnitude, probability and possibility was analysed and plotted in a three-dimension graph by using fuzzy probability technique (Karimi and Hüllermeire, 2007: pp.987-999). Furthermore, risk assessment can be done in various scales from global to local scale appropriate to any specific purposes.

According to the levels of disaster management, vulnerability can be defined separately in several layers as the following figure (Fig2).

Beyond those traditional methods, GIS and spatial analysis provide an effective way to illustrate the risk levels by considering the topographical terrain, land properties and the real time rainfall intensity. This method is applicable for indentifying risk level in regional to the local scale response to the resolution of the based map.

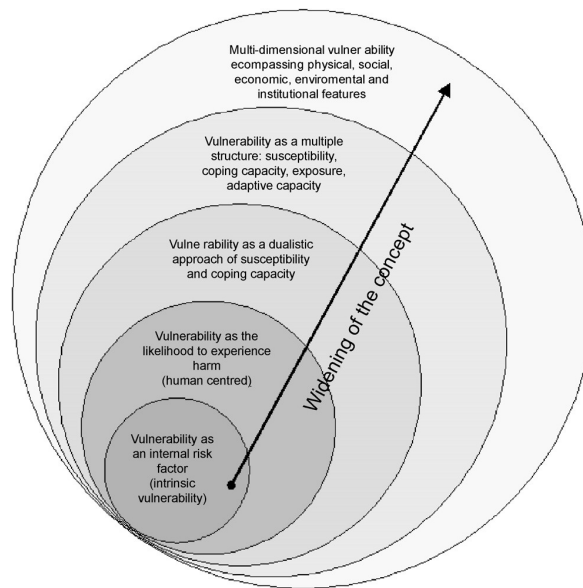

Fig 2: The spheres of vulnerability, Source: (Birkmann, 2005)

3. Resettlement programmes after natural hazard events

3.1 Terms of resettlement programme

Resettlement is the process by which people leave their original settlement sites to resettle in new areas (Woube, 2005). The resettlement programme is possibly included the procedures from finding the places for temporary shelters to construct the permanent house in the origin or new places (Deruyttere et al., 1998). The term of resettlement can be found as relocation and, also, rehabilitation. The framework of resettlement has been remarkably outlined in many regulations of the principles of resettlement by the United Nations in order to determine the compatibility of the resettlement programme and human rights. It also described in the UN comprehensive Human Rights Guidelines on Development-Based Displacement, 1997 that resettlement must ensure equal rights to women, children and indigenous populations and other vulnerable groups including the right to property ownership and access to resources with respect to education, health, family welfare and employment opportunities (Batra and Chaudhry, 2005: pp.1-139).

3.2 Effective resettlement programmes

In order to rebuild the houses and communities after the disaster, it was recommended not only just build it back but also build it better which can create the safer and better place (UNDP (United Nations Development Programme), 2009). As same as a study of Bartolome et al (2000: pp.1-61), it was recommended that an effective resettlement programme must be to improve the standard of living and not just restoration of pre-relocation standards of living and it is only possible where development takes place. Considering to the resettlement strategies applied in Somalia, for instance, the permanent resettlement project was assigned to substantially improve the internally displaced people protection and security of tenure, to access the basic service and infrastructure (especially water and sanitation) and to provide a solid base for income-generating activities (Ashmore et al., 2008). As a framework of the operational policy, resettlement plan must be prepared to ensure that the affected people receive fair and adequate compensation and rehabilitation (Deruyttere et al., 1998).

Two groups of resettlement characteristics are considered to evaluate the efficiency of resettlement programme such as the implementation characteristics and outcomes of resettlement. Kinsey and Binswanger (1993: pp.1477-1494) classified all considered variables in implementation characteristics of resettlement which are scale (overall size, average holding size, and number of settler families), organisation (public, private, spontaneous or mixed), sources of funding and credit for land acquisition and infrastructure, settler selection rules and practice, land allocation rules and practice, land rights (freehold/leasehold/tenancy, pledging, subdivision, inheritance), restrictions (crops grown, markets, employment and others), provision of infrastructure and speed of construction, access to and modality of supply or production services (credit, extension, tillage, irrigation, storage, marketing and transport), access to the modality of supply of social services (health care, education, housing, water and sanitation), quality of the resource base (soils and water), cost per beneficiary family, grant elements (in land cost, infrastructure, credit, and social services), cost recovery rules (for land, infrastructure, social services, and credit), costs and timing of cost recovery, and the speed of formation (speed of organisation, autonomy, and participation of settler groups). Kinsey and Binswanger (1993: pp.1477-1494) also classified all variables in the outcomes of resettlement which are yields and production levels, family income levels, asset accumulation and savings,

consumption levels, poverty alleviation, responsive capacity, diversification of production patterns, land trading and re-aggregation and/or subdivision of holdings, environmental impacts, stability of settlement, and sustainability of farming systems. Cernea (1997: pp.1569-1587) proposed a comprehensive theoretical framework of risks and reconstruction model associated with resettlement programme as i) Diagnose function of past resettlement, ii) Convert the diagnosis into a prognosis for better planning, iii) Encompass the explanation toward action, iv) Formulate hypotheses and conduct theory-led fieldwork.

Therefore, the above mentioned variables can be divided into two categories as physical aspects and social aspects considered in resettlement programme. An effective resettlement programme also requires the management in several scales. Certainly, the local management is essential to achieve an effective resettlement programme response to the regional policy as a scope of framework.

4. Risk assessment for the resettlement programmes

Risk levels are the outcome of risk assessment illustrated in several ways such as graph (e.g. UNDP (United Nations Development Programme), 2004), chart (e.g. Birkmann, 2005) and map (e.g. DMR (Department of Mineral Resources), 2008). Risk information is set as a tool for identifying the potential hazard areas to support resettlement activities. As a model modified by Cernea (1997: pp.1569-1587), risk assessment was prepared for resettlement activities corresponding the early warned resettlers. Therefore, risk analysis is essential to support the sustainable resettlement programmes in multiple scales such as the national scale for mitigation and preparation policy, the medium scale for controlling and providing some emergency assistances and the local scale for supporting the resettle management. Risk maps at national and medium scale are widely implemented in all countries where disasters occurred. However, the risk map in local scale is rarely produced due to the available advanced technology and supports. Producing risk map for the local resettlement programme management requires the advanced technology, the application of Geographic Information System (GIS) and Remote Sensing Imagery.

One of the most advantage applications of GIS and Remote Sensing image response to the resettlement activities is investigating the vulnerability hazard areas and

identifying areas for new resettlement sites. In order to achieve this task, high resolution image from remote sensing technology is applicable to provide the finest detail of topography, houses and communities. The minimum sizes of objects recognised in satellite image and aerial photos are listed in Table 1. The spatial resolution (m) determines the size of object in the topographical terrain considered in the resettlement activities. The acceptable spatial resolution displayed in the satellite images is lower than 5 m related with the common size of houses which is able to clearly display in the image. Therefore, the PAN (panchromatic image) from SPOT5 is the maximum resolution acceptable for producing the based map for resettlement programme. As well as the MS (Multispectral) and PAN imaged of IKONOS and Quick Bird including aerial photos, these are able to implemented as based maps for resettlement activities. Nevertheless, prices of those products and the available scenes are also the most common thing considered in the implementation.

Table1: Minimum sizes of objects to be recognised for various condition of contrast in most common satellite images and aerial photos

Spatial Resolution	LANDSAT 7		SPOT 5		IKONOS		Quick Bird		Aerial Photos	
	MS	PAN	SX	PAN	MS	PAN	MS	PAN	1:25,000	1:10,000
Spatial resolution (m)	30	15	10	5	4	1	2.44	0.61	0.25	0.1
Ground resolution cell Size (m ²)	900	225	100	25	16	1	5.95	0.37	0.0625	0.01
High back ground contrast Area m ² (10 pixels)	9,000	1,500	1,000	500	400	100	59.5	3.7	0.625	0.1
Low back ground contrast Area m ² (40 pixels)	36,000	6,000	4,000	2,000	1,600	400	238	148	2.5	0.4

Source: Rangers et al. (1992: pp.36-45)

5. Conclusion

It can be concluded that the maximum spatial resolution of satellite image is 5 m. Therefore, the panchromatic image of SPOT5 is preferred in resettlement programme. Additionally, the IKONOS and Quick Bird products are also applicable to produce a good quality of risk map at large scale. Apart from the remote sensing images appropriate to produce a based map for resettlement activities, spatial analysis techniques in GIS environment is another crucial tool for analysing the topographic terrain related to resettlement programme.

As a modified framework based on a study of Jeber et al. (2008: pp.470-477), the output as hazard risk maps is further implemented in resettlement programme associated with this study as the Fig 3.

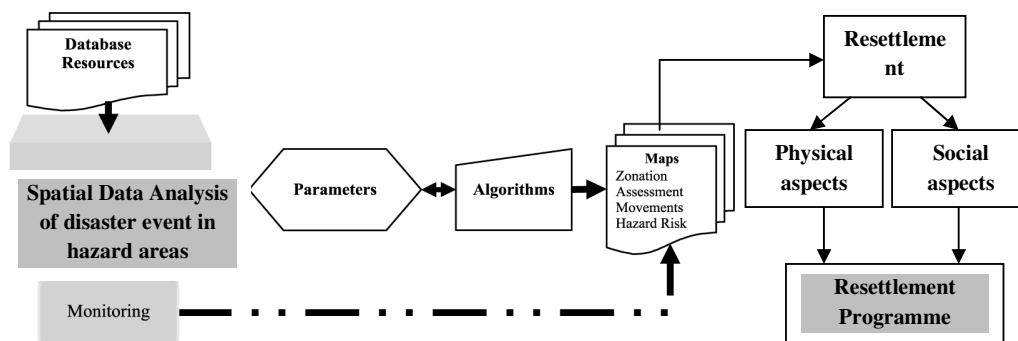

Fig 3: Framework of producing hazard risk maps for resettlement programme

From the above mentioned variables, it is clear that there are physical aspects and social aspects considered in resettlement programmes. Both physical and social aspects associated with the resettlement activities are crucial to classify in order to set an effective sustainable resettlement programme. Furthermore, the existing economic and social fabric of the entire neighbourhoods is necessary to be considered to improve the resettlement programme. According to the proposed reviews of factors involving the resettlement programme, social factors and the existing economic and social fabric of the entire neighbourhoods is rarely considered in this programme. Therefore, these parameters would be carefully set as the conditions in spatial analysis application for the sustainable resettlement programme.

6. Discussion

Due to the fastest response to identify the damage levels of destructive houses in hazard areas can reduce the constraint and relief the suffering from affected people. However, in-situ data collected in hazard zones after the disaster event is almost impossible due to the difficulty of the accessibility. Therefore, the application of the remote sensing techniques and real-time/near real-time image of the hazard zones are essential to clarify this obstacle. This application provides an opportunity to produce the real-time/near real-time risk map at multiple scales. Furthermore, series of the available images in the hazard area present the continued evidences of land-use change for any investigations. The land use and land cover is an important parameter considered in the resettlement programme. However, the large scale risk map produced from remote sensing image and generated from spatial analysis may contain some errors which the users need to be careful to implement it.

7. References

- ASHMORE, J. FOWLER, J. and KENNEDY, J., 2008. Shelter Projects 2008. In: ASHMORE, J. ed. *IASC Emergency Shelter Cluster*. UN-HABITAT.
- BARTOLOME, L. J. WET, C. D. MANDER, H. and NAGARAJ, V. K., 2000. Displacement, Resettlement, Rehabilitation, Reparation and Development. In: *World commission on Dams*. Cape Town, South Africa, 16 March 2000.
- BATRA, B. J. and CHAUDHRY, S., 2005. International Human Rights Standards on Post-disaster Resettlement and Rehabilitation. *UN Comprehensive Human Rights Guildelines on Development-Based Displacement, 1997*. Geneva: Office of the United Nations High Commissioner on Human Rights.
- BIRKMANN, J., 2005. Danger need not spell disaster-but how vulnerable are we? *Research Brief number 1*. Tokyo: United Nations University.
- BIRKMANN, J., 2007. Risk and vulnerability indicators at different scales: Applicability, usefulness and policy implications. *Environmental hazards*, 7 (2007), pp.20-31.
- BROOKS, N. ADGER, W. N. and KELLY, P. M., 2005. The determinants of vulnerability and adaptive capacity at the national level and the implications for adaptation. *Global Environment Change*, 15 (2005), pp.151-163.

- CARDONA, O. D., 2005. Indicators of disaster risk and risk management-main technical report. *IDB/IDEA Program of Indicators for Disaster Risk Management*. Manizales: National University of Colombia.
- CARDONA, O. D., 2006. A system of indicators for disaster risk management in the Americas. In: BIRKMANN, J. ed. *Measuring Vulnerability to Natural Hazards-Towards Disaster Resilient Societies*. Tokyo.
- CARDONA, O. D. BANKOFF, G. FRERKS, G. and HILHORST, D. eds., 2004. *The need for rethinking the concepts of vulnerability and risk from a holistic perspective: a necessary review and criticism for effective risk management*. London: Earthscan Publishers.
- CERNEA, M., 1997. The risks and reconstruction model for resettling displaced populations. *World Development*, 25 (10), pp.1569-1587.
- DERUYTTERE, A. RENSHAW, J. ROJAS, E. DAUGHTERS, R. BRANSKI, J. PERAZZA, M. C. SOLORZANO, A. and BURROUGHS, N., 1998. Involuntary Resettlement: Operational Policy and Background Paper. In: *The sixth IDB-NGO consultative meeting on the environment*. Curitiba, Brazil, 27-30 November 1995.
- DMR (DEPARTMENT OF MINERAL RESOURCES), 2008. Landslide: Statistical landslide occurrences in Thailand. DMS's Operation Center; Department of Mineral Resources, Thailand.
- DUBIE, M. E., 2005. *The socio-economic dimensions of resettlement programme in Ethiopia: The case of Golollee Nonnoo resettlement scheme (West shewa of Oromiya regional state)*. Master of Art in Regional and Local Development studies, Addis Ababa
- HE, Y. and BEIGHLEY, R. E., 2007. GIS-based regional landslide susceptibility mapping: a case study in southern California. *Earth Surface Processes and Landforms*.
- JEBER, F. OMAR, H. MANSOR, S. AHMAD, N. and MAHMUD, M., 2008. Satellite data potential for landslide studies in tropical regions. *Disaster Prevention and Management*, 17 (4), pp.470-477.
- KARIMI, I. and HÜLLERMEIRE, E., 2007. Risk assessment system of natural hazards: A new approach based on fuzzy probability. *Fuzzy sets and systems*, 158 (2007), pp.987-999.
- KARIMI, S. NAKAYAMA, M. FUJIKURA, R. KATSURAI, T. IWATA, M. MORI, T. and MITZUTANI, K., 2005. Post-project review on a resettlement programme of

- the Kotapanjang Dam Project in Indonesia. *Water Resources Development*, 21 (2), pp.371-384.
- KINSEY, B. H. and BINSWANGER, H. P., 1993. Characteristics and performance of resettlement programs: A review. *World Development*, 21 (9), pp.1477-1494.
- NAKANO, T. KADOMURA, H. MIZUTANI, T. OKUDA, M. and SEKIGUCHI, T., 1974. Natural hazards report from Japan. *Natural Hazards Local, National, Global*. In G.F. White ed. New York: Oxford university Press.
- PANDE, R. K., 2006. Hazard zonation in Uttaranchal (India): a tool to understand the problem. *Disaster Prevention and Management*, 15 (4), pp.598-607.
- PELLING, M., 2004. Visions of risk. *A review of International indicators of disaster risk and its management*. Geneva: UNDP-Bureau for Crisis Prevention and Recovery (BRCP).
- PEROTTO-BALDIVIEZO, H. L. THUROW, T. L. SMITH, C. T. FISHER, R. F. and WU, X. B., 2004. GIS-based spatial analysis and modeling for landslide hazard assessment in steeplands, southern Honduras. *Agriculture, Ecosystems and Environment*, 103 (2004), pp.165-176.
- RANGERS, N. SOETERS, R. and WESTEN, C. J., 1992. Remote sensing and GIS applied to mountain hazard mapping. *Episodes*, 15 (1), pp.36-45.
- REMONDO, J. BONACHEA, J. and CENDRERO, A., 2006. Quantitative landslide risk assessment and mapping on the basis of recent occurrences. *Geomorphology*, 94 (2008), pp.496 - 507.
- RUFIN-SOLER, C. HÉQUETTE, A. and GARDEL, A., 2008. Assessing the vulnerability of coastal lowlands to marine flooding using LiDAR data, Sangatte coastal dunes, Northern France. *Zeitschrift für Geomorphologie*, 52 (Supplementary Issues), pp.195-211.
- SAUCHYN, D. J. and TRENCH, N. R., 1978. Landsat applied to landslide mapping. *Photogrammetric Engineering and Remote Sensing*, 44 (June 1978), pp.735-741.
- SCHULZ, W. H., 2004. Landslide mapped using LIDAR imagery, Seattle, Washington. Seattle: USGS.
- UN/ISDR (UNITED NATIONS INTERNATIONAL STRATEGY FOR DISASTER REDUCTION), 2004. Living with risk. *A Global review of disaster reduction initiatives*. Geneva: UN/ISDR.
- UNDP (UNITED NATIONS DEVELOPMENT PROGRAMME), 2004. Reducing disaster risk. *A Challenge for development*. New York: UNDP.

UNDP (UNITED NATIONS DEVELOPMENT PROGRAMME), 2009. A *Contribution to the 2009 ISDR Global Assessment Report on Disaster Reduction*. [e-book]. Pub. Available through:
<http://www.preventionweb.net/english/hyogo/gar/background-papers/documents/Chap5/thematic-progress-reviews/recovery/UNDPBCPR-ERT.doc>
[Accessed 18 Nov 2009].

VARNES, D. J., 1984. Landslide hazard zonation: A review of principles and practice
In: *Natural Hazards 3, International Association of Engineering Geology*. UNESCO.

WMO (WORLD METEOROLOGICAL ORGANIZATION), 1999. *Comprehensive Risk Assessment for Natural Hazards*. Switzerland: WMO.

WORLD ALMANAC, 2000. *Environment global warming and greenhouse effect*.

WOUBE, M., 2005. Effects of resettlement schemes on the biophysical and human environments: The case of the Gambela Region, Ethiopia. Florida, USA.

Web 2.0: the use of online Social Networking Sites (SNSs) for marketing Higher Education (HE)

Arash Raesi, *University of Salford*

Abstract

This paper discusses the potential impact of online Social Networking Sites (SNSs) for marketing Higher Education (HE). The approach for this study entailed historical review of marketing HE and challenges in global HE market, extensive literature review of Web 2.0 core concepts, Web 2.0 marketing and marketing opportunities in SNSs. Based on existing studies on online social media, SNSs are believed to be among most popular Web 2.0 tools and should therefore not be neglected by HE institutions as a means to promote their offerings, to target and select prospective students who can meet their requirements and many other potential benefits. Existing studies verify that HE institutions can benefit from Web 2.0 tools in a number of issues such as teaching and learning, academic publishing, libraries, repositories and archiving, knowledge management and distance education. However academic research on the use of SNSs for marketing HE is still at an embryonic stage, accordingly this paper makes a significant conceptual contribution and presents issues for further research.

Keywords:

Information systems; Web 2.0; Marketing; Social Networking Sites; higher education

1. Introduction

In recent times, the development of Web 2.0 tools and rising recognition of them among different age groups have had an extraordinary impact on the way organizations carry out marketing activities. In accordance with a Nielsen report (2009a) Web 2.0 tools, predominantly Social Networking Sites (SNSs) and video sites, have transformed the World Wide Web and the online advertising market. There are 87 percent more online social media users in 2010 than in 2003, with 883 percent more time dedicated to those sites (Nielsen, 2009a). Web 2.0 presents Higher

Education (HE) institutions with new opportunities for staying in touch with their publics and learning about their needs and opinions. Marketing HE has been the centre of attention for scholars and practitioners for a long time. Particularly in our time it has attracted the attention of many people such as faculty deans, chief operating officers and directors of marketing. HE market in our time is a global phenomenon particularly in the English speaking nations such as Canada, Australia, the UK and the US, and this is what Hemsley-Brown & Oplatka (2006) considered to be the most significant challenge facing HE institutions, and they stated that “in the context of increasing competition for home-based and overseas students, HE institutions now recognise that they need to market themselves in a climate of international competition”. For example, in 2007/08 academic year the number of Americans study abroad increased by 8.5% to 262,416, increasingly heading to less traditional places such as China, Japan and Argentina (IIE, 2009a). Also the number of international students studying at colleges and universities in the USA increased by 8% to 671,616 in 2008/09 academic year (IIE, 2009b). There are over 460, 000 international students studying in higher and further education in the UK (British Council, 2009). As reported by the UK Council for International Student Affairs (UKCISA, 2009), Republic of Ireland, Germany, France, Greece and Cyprus are five top EU sending countries and China, India, United States of America, Nigeria and Malaysia are top five non-EU senders. During the 2008/09 academic year, international students and their dependents contributed approximately US\$17.6 billion to the US economy (NAFSA, 2009), over CA\$6.5 billion to Canadian economy (DFAIT, 2009) and they contribute almost £12.5 billion per year to the UK economy (British Council, 2009). Existing studies verify that HE institutions can benefit from Web 2.0 tools in a number of issues such as Teaching and learning (e.g. Ketterl *et al.*, 2008; Scutter, *et al.*, 2010; Hourigan & Murray, 2010), Libraries, repositories and archiving (e.g. Miller, 2005, 2006; Crawford, 2006; Berube, 2007), academic publishing (e.g. Thompson, 2005; Swan, 2006; Pochoda, 2009), knowledge management (e.g. Yan, *et al.*, 2008) and distance education (e.g. Kesim & Agaoglu, 2007). However academic research on the use of SNSs for marketing HE is still at an embryonic stage, as a result this paper makes a significant conceptual contribution and presents issues for further research.

2. A historical review of marketing higher education and challenges in global higher education market

In education market, the nature of the product and buyer/supplier relationship varies, some scholars view graduates the products of HE institutions and others see courses as products being offered. For example Kotler & Fox (1985) as cited in Binsardi & Ekwulugo (2003, p.319), suggested that “students are raw materials, graduates the product, and prospective employers the customer”. Kotler & Fox (1985, p.13) argued that “some educators abhor the idea of marketing; other are interested but feel that marketing must be introduced cautiously”. They further stated that “two main criticisms may arise: 1) marketing is incompatible with the educational mission 2) marketing should not be needed” (Kotler & Fox,1985, p.13). Conway *et al.* (1994) conducted an exploratory research on UK’s higher education to discover the degree to which new universities and higher education colleges apply a market orientation to their strategic planning. Their methodology was based on content analysis of the mission statement of institutions in order to assess the degree to which colleges had considered their role and position in the relatively new competitive environment. Their results suggested that majority of institutions tended to be predominantly product driven and their products being seen merely as courses or perhaps, in some instances, the broader product-education (Conway *et al.*, 1994, p.34). In recent times HE institutions are facing various challenges globally, for example in the UK, with “tougher rules for non-EU students” (Directgov, 2010) and “with the squeeze in domestic funding, universities are seeking to maximise other sources of income” (Baker, 2010). As a result British universities should incorporate an effective target marketing strategy that would enable them to attract sufficient number of students globally who can meet government policies. Besides the challenges brought forward by globalisation and legislation, Baldwin & James (2000, p. 146) raised another issue in the context of Australian HE. They suggested that “students need to be given facts which will allow them to develop a stronger imaginative grasp of the actual experience of studying in their chosen course. There is convincing evidence that the high drop-out rate of students in higher education is related to a lack of knowledge of what they were getting into.” In regards to British universities, Bakewell & Gibson-Sweet (1998, p. 109) found that “in terms of choosing between institutions students admitted that they often had little and incomplete knowledge” and old universities are

perceived as better choices. They further suggested that “Whatever strategic direction is adopted, it is clear from the competitive situation within higher education markets that British universities will probably have to undertake a more considered and professional stance regarding their marketing approach” (Bakewell & Gibson-Sweet, 1998, p.112). A review of the literature in this section indicates the importance of marketing HE, consequently formulating an effective marketing strategy is an imperative strategic choice for HE institutions and should therefore not be neglected.

3. Evolution of World Wide Web into Web 2.0

Over the past two decades, information and communication technologies (ICTs) have become principal derivations of social revolution. The World Wide Web, which was invented by Sir Tim Berners-Lee, “was developed to be a pool of human knowledge, which would allow collaborators in remote sites to share their ideas and all aspects of a common project” (Berners-Lee *et al.*, 1994, p. 76). In recent times the web-based communities have transformed the way that users access content and interact with each other. Examples of such communities are Facebook, MySpace, Twitter and YouTube. In literature numerous terminologies can be found to demonstrate this phenomenon such as “Web 2.0” (O’Reilly, 2005) and “Social software” (Shirky, 2003; Bächle, 2006; Fuchs et al. 2010). The concept of Web 2.0 began with a conference brainstorming session between O’Reilly and MediaLive international in 2004 (O’Reilly, 2005). Web 2.0 has several definitions, O’Reilly (2006) defined Web 2.0 as follows:

“Web 2.0 is the business revolution in the computer industry caused by the move to the Internet as platform, and an attempt to understand the rules for success on that new platform. Chief among those rules is this: Build applications that harness network effects to get better the more people use them.”

According to Murugesan (2007, p. 34) “Web 2.0 is both a usage and a technology paradigm. It is a collection of technologies, business strategies, and social trends”. Web 2.0 tools allow “users to collaboratively create, share and recreate knowledge from multiple sources, leverage collective intelligence and organise action” (Eijkman, 2008, p.94). “What makes Web 2.0 new and important is its capacity to change the

relationship between the Internet and its users” (Kes-Erkul & Erkul, 2009, p.5). Authors such as Birdsall (2007), Beer & Burrows (2007), Wigand et al (2008) and Fuchs et al (2010) place Web 2.0 in the broader context of social movement, for example Birdsall (2007) argued that “Web 2.0 represents a continuing manifestation of a social movement arising out of the interaction between technological developments in communication and the expansion of communication rights, in particular, a basic human right to communicate for everyone.” In order to best realize the phenomenon of Web 2.0, this section attempts to encapsulate what O’Reilly (2005) considered to be the core competencies of Web 2.0 organizations, they are shown in Table 1.

Table 1: A summary of core competencies of Web 2.0

<i>core competencies of Web 2.0</i>	<i>Description and examples</i>
The web as platform	For Web 2.0 organizations success derives from comprehending what Anderson (2004) refers to as “the long tail”. It is the understanding of the fact that most of the Web’s content is made up of small sites. In this condition Web is perceived as a programming platform upon which developers design and institute software applications.
Harnessing collective intelligence	A highly powerful and productive approach of adding worthy content to a website is to inspire users to provide data in a constructive way. This approach is also defined as “the wisdom of crowd” (Surowieck, 2004), e.g. Google’s page rank and search algorithms.
Data is the next Intel inside	Majority of the Web 2.0 tools are fundamentally database driven. Web 2.0 companies utilize data to make their websites compelling and entertaining.
End of the software release cycle	We no longer require a very expensive computer packed with mixture of up to date software, “one of the defining characteristics of Internet era software is that it is delivered as a service, not as a product” (O’Reilly, 2005).
Lightweight programming models	The Web 2.0 applications use the lightweight programming models to initiate mashups. The latest generation of WWW tools and services enables web users to generate web applications that combine content from multiple sources, and provide them as unique services that suit their situational needs. This type of web applications is referred to as a ‘Mashup’ (Tuchinda, <i>et al.</i> , 2008, p.139). RSS is a clear example of lightweight programming.

Software above the level of a single device	The Web 2.0 applications can also run on various devices and client platform such as iPhone, Android, Blackberry, Palm, in such a way that they will be able to deliver the same quality with superior performance
Rich user experience	Web 2.0 applications accommodate a comparable experience as a computer based software. A crucial constituent that facilitates this kind of practice is AJAX. AJAX is a group of technologies used together to generate a rich user experience, e.g. Google Maps and Gmail.

4. Evolution of marketing into Web 2.0 marketing

Marketing nowadays refers to the discipline that guarantees long-lasting customer fulfilment. The definition of marketing derives from the UK's Chartered Institute of Marketing (2010):

“Marketing has been described as the management process responsible for identifying, anticipating and satisfying customer requirements profitably.”

This section attempts to review marketing literature in an evolutionary pattern from traditional marketing towards a more Internet-enabled marketing environment and eventually Web 2.0 marketing. The field of traditional marketing is very broad and “a variety of schools of thought have been located in a diverse literature” (Sheth *et al.*, 1988). The theories of marketing have developed from the rather production and sales orientation of earlier times to what Bartels (1976) described as “the period of socialization”. It was not really until the 1970's and 1980's that marketing generally moved away from an inside out perspective to outside in perspective wherein appreciating customers' current and future needs and the causes affecting them become top concerns for practitioners and scholars (e.g. Kohli & Jaworski, 1990; Narver & Slater, 1990). Since 1990's we have been witnessing the emergence of new marketing literature, predominantly “the evolution of the marketplace into an Internet-enabled market environment and the digitization of information products, over the past decade, have had a major impact on contemporary marketing thoughts and practice” (Varadarajan & Yadav, 2009, p.11), more detailed historical overviews and discussions can be found in Glazer (1991, 1993); Morgan (1996); Kierzkowski *et al.* (1996) and Armstrong & Hagel (1996). The World Wide Web is “faster, less expensive, round the clock and global in compare to traditional marketing

communications channels”, moreover it “allows bi-directional marketing and offers wider and deeper material and richer advertisement content” (Ellsworth & Ellsworth, 1995). Hoffman & Novak (1996, p.50) argued that “the Internet operationalizes a model of distributed computing that facilitates interactive multimedia many-to-many communication”, they also suggested that “ the Web provides an efficient channel for advertising, marketing, and even direct distribution of certain goods and information services” (Hoffman & Novak, 1996, p.51). The Internet has constructed a “marketspace” that has a number of distinctive characteristics, “the marketspace is: shared, real-time, global and open” (Arnott & Bridgewater, 2002, p.86). The emergence of Web 2.0 has brought new challenges and new directions for scholars in both traditional and Internet marketing disciplines, for example Kotler, who is designated the first leader in marketing thought by the American Marketing Association (AMA), and his colleagues Kartajaya and Setiawan (2010, p5) asserted that “technological advances have brought about huge changes in consumers, markets, and marketing over the past century” and they defined this phenomenon as “the new wave technology” which is “technology that enables connectivity and interactivity of individuals and groups”. Kotler, *et al.* (2010, p4) noted that “values-driven” marketing is the most recent phase of development in marketing and it treats people as potential collaborators and “instead of treating people simply as consumers, marketers approach them as whole human beings with minds, hearts, and spirits.” In the 21st century people are at the heart of organizations’ marketing campaigns and this indeed entails a collaborative marketing approach which is now extensively acknowledged by scholars and practitioners. According to Fagerstrom & Ghinea (2010, p. 67) “Web 2.0 marketing is an emerging concept”, nevertheless “ the experience so far, based to a large degree on anecdotal evidence, is that Web 2.0 has a substantial effect on consumer behaviour and contributed to an unprecedented customer empowerment” (Constantinides & Fountain, 2007, p.231). Constantinides & Fountain (2007, p.233) pointed out that “the user is a vital for all categories of Web 2.0 applications, not only as a consumer but mainly as a content contributor”, they further argued that “the value attributed to these applications is not based on the classic customer value approach but rather on some feeling of achievement through personal gratification”.

5. Marketing opportunities in Social Networking Sites

The landscape of online social media is very large and it consists of SNSs, Blogs, virtual worlds, entertainment platforms, live casting, video sharing, social news, social book marketing and many others. According to a Nielsen report (2009b) two-thirds of the world's Internet population visit a SNS or blogging site. SNSs are now the fourth most popular activity on the Internet after search, general interest portals and communities, and software manufactures. Based on a simple design, broad demographic appeal and a focus on connecting, Facebook has become the largest player on the global stage followed by MySpace, Classmates Online, Orkut and LinkedIn. Facebook has the greatest reach in the UK, being visited by 47% of Britons online followed by Italy, Australia and USA (Nielsen, 2009b). Also an eMarketer report (2009) noted the continued importance of SNSs, predominantly Facebook, which is the premier destination for marketers in the US and many worldwide markets. It is estimated that by the end of 2010, Facebook will account for nearly one-quarter of all social network advertisements spending worldwide, up from 20% in 2009 (eMarketer, 2009). Facebook's Press Room (2010) revealed that Facebook now has more than 500 million active users who spend over 700 billion minutes per month on Facebook and there are more than one million developers and entrepreneurs from more than 180 countries. This raises the question of why SNSs are among most popular Web 2.0 tools. In order to answer this question this section first elucidates the term 'social network'. Clemons, *et al.* (2007, p.267) defined the term social network as "ongoing relationships among people that matter to those engaged in the group, either for specific reasons (like fantasy football, cancer support groups, task focus at work) or for more general expressions of mutual solidarity (like families, clans, friends, social clubs)." People use social networks for a variety of reasons, nevertheless the main motivation is "communication and maintaining relationships" (Dwyer, *et al.*, 2007). The users can trust social networks "because of shared experiences and the perception of shared values or shared needs" (Clemons, *et al.*, 2007, p.268). Online social networks such as Facebook and MySpace have various motivational aspects that influence users to use them incessantly, "part of Facebook's persuasion is due to the fact that members connect with already existing friends and then expand the network through the familiarity and similarity of those friends" (Ferebee & Davis, 2009). The analysis of reports and the growing body of literature in

this section illustrates that SNSs are among most popular Web 2.0 tools and they have the potentials to support a range of marketing activities for HE institutions which are discussed in the following section.

6. Potential impact of social networking sites on marketing higher education

The potential benefits of Marketing HE over SNSs goes beyond the traditional marketing HE strategies such as bursary scheme and email marketing or promotional strategies such as “relatives, local universities, consultants” (Binsardi & Ekwulugo, 2003). It is not the intention of this paper to argue against the traditional methods of marketing HE, rather this paper argues that HE institutions can use SNSs as a platform to also deliver all their traditional marketing messages and take advantage of SNSs’ unique competencies which are shown in the following table.

Table 2: Potential impact of social networking sites on marketing higher education

	<i>Key concepts of SNSs</i>	<i>Initial thoughts on impact on Marketing HE</i>
1	Harnessing collective intelligence	SNSs, based on their unique collaborative nature, allow past, current and prospective students, members of staff, local community, government agencies, business community, trustees and others to participate in discussions, leave comments and discuss their own thoughts. SNSs allow HE institutions to learn about their images and change their images if it is required. They can also assist HE institutions in strategic planning, predominantly major trends in HE global market, and designing and pricing educational programmes.
2	Market oriented	SNSs can facilitate an outside in perspective in which understanding of a HE institution’s publics such as current and prospective students’ needs and the factors affecting them become top priorities.
3	Highly targeted advertising	HE marketers can create targeted adverts and target prospective students based on their profile content. For example Facebook's adverts are able to target exact demographic in terms of different countries or even cities, age, sex and others. Therefore HE marketers can target prospective students who can meet their requirements.

4	Database driven and Well-structured	SNSs are database driven, the data is the collective activity of all users and can help both HE institutions and their publics. For example prospective students can obtain information on different programmes and admission process, and also the data will allow HE institutions to modify and improve their services and meet needs of their current and prospective students. Moreover new features of SNSs provides richer experiences. For instance Facebook pages have Tabbed structure which can help HE institutions to keep pages organized so people can easily find different pieces of information such as information about institutions, courses offerings, discussions, campus images, videos, events, reviews, etc.
6	Encourage user participation	SNSs can encourage more social actions and people can discuss various issues and provide feedback. For example a new marketing post on Facebook can automatically appears in Fan's News Feeds and motivate Fans to participate in discussions. Also HE marketers can observe and trace the behaviour of people via their participation in discussions and their comments.
7	Highly popular across different age groups	SNSs are among most popular Web 2.0 tools and posses the most potential for Marketing HE. For example Facebook has 500 million active users, MySpace 130 million. SNSs attract different age groups, according to a report by Clickymedia (2010) Facebook in the UK is most popular among 20-29 age group, followed by 13-19 and 30-39 age groups. As a result Social network demographics possess vast opportunities for HE marketers in targeting different age groups for undergraduate, postgraduate taught and postgraduate research programmes.
8	Glocalized	SNSs are glocalized. In other words they think globally and act locally. Majority of online social networks support different languages. Accordingly HE marketers can deliver their marketing messages in a variety of languages and attract people from different locations and cultural backgrounds.
9	Less expensive than traditional marketing communication s channels	Marketing over SNSs are less costly than traditional methods. HE institutions can create social networking groups free of charge and attract a large number of members. Furthermore HE marketers can incorporate advertising methods such as Pay Per Click (PPC) or Pay Per Impressions (CPM) with budgets as low as £5!
10	Automated trend discovery	Some SNSs such as Facebook allow marketers to see how many comments Fans make on posts, and marketers also are able to track how many users start and stop viewing posts in

		News Feed. It is an effective way to assess popularity of a marketing message, it can also assist HE institutions in marketing research, for example how many students might be interested in a particular programme. As a result automated trend discovery can assist HE institutions in forecasting future market demand.
11	User-friendly	SNSs are easy to use and HE marketers do not require vast technical skills or expensive computers packed with latest software to use these services.
12	Easily accessible	HE marketers can constantly monitor activities on SNSs via various devices such as iPhone and Blackberry
13	No barriers to international marketing	HE institutions can develop and run marketing campaigns globally regardless of political, economic and socio-cultural differences.
15	Faster marketing tactic than traditional marketing methods	A marketing message can spread much faster on SNSs than traditional marketing techniques. A marketing message spread through a process which is referred to as viral marketing. SNSs have several tools which can facilitate viral marketing such as Tagging, News Feed, Events, Photos and market place. Also HE institutions can use viral marketing technique as a key part of their branding strategy.

7. Conclusions and issues for further research

The aim of this paper was to provide an overview of the use of Web 2.0, particularly SNSs, for marketing HE. Based on growing body of literature on online social media, this paper proposed that SNSs are among most popular Web 2.0 tools and seem to possess the most potential for marketing HE. However academic research on the use of SNSs for marketing HE is still at an embryonic stage, consequently this issue presents a challenging research domain that should embrace a number of questions as follows;

- What are the factors that either encourage or discourage the implementation of an effective SNS marketing strategy within the HE sector?
- What are the prospective students' preconceptions, preferences or decision making process for selecting a particular HE institution on SNSs? What are the influential factors that effect decision making, whether environmental,

psychological or sociocultural? Do prospective students normally rely on the information presented on SNSs?

- What segments in consumer markets [e.g. UK, EU, overseas, undergraduate, postgraduate taught, postgraduate research, full-time, part-time, adult students etc.] are more influenced by Social Network Marketing campaigns in terms of geographic, demographic, geodemographic and psychographic? And what is the best strategy to segment consumer markets?

8. References

- Anderson, C. (2004). *The long tail*. [Online]. Available from: <http://www.wired.com/wired/archive/12.10/tail.html>. [Accessed: 7/05/2010]
- Arnott, D. C. & Bridgewater, S. (2002). Internet, interaction and implications for marketing. *Marketing Intelligence & Planning*. 20 (2). P. 86-95
- Armstrong, A. & Hagel, J. (1996). The real value of online communities. *Harvard Business Review*. 74 (3). P.134-141
- Berube, L. (2007). *On the Road Again: The next e-innovations for public libraries?*. [Online]. Available from: <http://www.bl.uk/aboutus/acrossuk/workpub/laser/news/awards2005/einnovations.pdf>. [Accessed: 3/03/2010]
- British Council. (2009). *British council awards shine spotlight on international students' achievements*. [Online]. Available from: <http://www.britishcouncil.org/usa-about-us-newsroom-press-releases-international-student-of-the-year.htm>. [Accessed: 3/05/2010].
- Binsardi, A. & Ekwulugo, F. (2003). International marketing of British education: research on the students' perception and the UK market penetration. *Marketing Intelligence & Planning*. 21 (5). P.318-27.
- Bakewell, C. J. & Gibson-Sweet, M. F. (1998). Strategic marketing in a changing environment– are the new UK universities in danger of being 'stuck in the middle'?. *International Journal of Educational Management*. 12(3). P.108–113.
- Baldwin, G. & James, R. (2000). The Market in Australian Higher Education and the Concept of Student as Informed Consumer. *Journal of Higher Education Policy and Management*. 22 (2). P.139-148.

- Baker, M. (2010). British education is in danger of losing its appeal. *The Guardian* [Online]. Tuesday 16 March 2010. Available from: <http://www.guardian.co.uk/education/2010/mar/16/overseas-students-rising-costs>. [Accessed: 24/05/2010]
- Berners-Lee, T. et al. (1994). The World Wide Web. *Communications of the ACM*. 37 (8). P.76–82.
- Birdsall, W. F. (2007). Web 2.0 as a social movement. *Webology*. [Online]. 4(2). Available from: <http://www.webology.ir/2007/v4n2/a40.html>. [Accessed: 6/05/2010]
- Bartels, R. (1976). *The history of marketing thought*. 2d ed. Columbus: Grid Pub.
- Beer, D., & Burrows, R. (2007). Sociology And, of and in Web 2.0: Some Initial Considerations. *Sociological Research Online*, 12(5), 17.
- Crawford, W. (2006). Library 2.0 and “Library 2.0”. *Cites & Insights*. 6(2). P.1-32.
- Conway, T., Mackay, S. & Yorke, D. (1994). Strategic Planning in Higher Education: who are the customers?. *The International Journal of Educational Management*. 8 (6). P.29-36.
- Chartered Institute of Marketing. (2010). *Definition of marketing*. [Online] Available from: <http://www.cim.co.uk/resources/understandingmarket/definitionmktg.aspx>. [Accessed: 11/04/2010]
- Constantinides, E. & Fountain, S. J. (2008). Web 2.0: conceptual foundations and marketing issues. *Journal of Direct, Data and Digital Marketing Practice*. 9 (3). P.231-244.
- Clemons, E. K., Barnett, S., & Appadurai, A. (2007). The future of advertising and the value of social network websites: some preliminary examinations. In *Proceedings of the Ninth international Conference on Electronic Commerce*. Minneapolis, MN, USA, August 19 - 22, 2007. New York, NY: ACM. pp. 267-276.
- ClickyMedia. (2010). *UK Facebook User Statistics*. [Online]. Available from: <http://www.clickymedia.co.uk/2010/04/uk-facebook-user-statistics-april-2010/>. [Accessed: 14/04/2010].

- Department of Foreign Affairs and International Trade Canada (DFAIT). (2009). *International Students Contribute Over \$6.5 Billion to Canadian Economy*. [Online]. Available from: http://www.international.gc.ca/media_commerce/comm/news-communiqués/2009/319.aspx. [Accessed: 2/05/2010].
- Directgov. (2010). *Tougher rules for non-EU students*. [Online]. Available from: http://www.direct.gov.uk/en/N11/Newsroom/DG_185045. [Accessed: 25/05/2010].
- Dwyer, C., Hiltz, S. R., & Passerini, K. (2007). Trust and privacy concern within social networking sites: A comparison of Facebook and MySpace. [Online]. In *Proceedings of the Thirteenth Americas Conference on Information Systems*. Keystone, Colorado, August 09 – 12, 2007. Available from: <http://csis.pace.edu/~dwyer/research/DwyerAMCIS2007.pdf>. [Accessed: 12/05/2010]
- Eijkman, H. (2008). Web 2.0 as a non-foundational network-centric learning space. *Campus-Wide Information Systems*. 25 (2). P.93-104.
- Ellsworth, J.H. & Ellsworth, M.V. (1995). *Marketing on the Internet*. New York: John Wiley.
- eMarketer Inc. (2009). *Social Network Ad Spending: 2010 Outlook*. [Online]. Available from: http://www.emarketer.com/Report.aspx?code=emarketer_2000621. [Accessed: 4 /05/2010].
- Ferebee, S. S. & Davis, J. W. (2009). Factors that persuade continued use of Facebook among new members. In *Proceedings of the 4th international Conference on Persuasive Technology*. Claremont, California, April 26 - 29, 2009. New York, NY: ACM. pp. 1-8.
- Fagerstrom, A. & Ghinea, G. (2010). Web 2.0's marketing impact on low-involvement consumers. *Journal of Interactive Advertising*. 10 (2). P.67-71.
- Facebook Press Room(2010). *Facebook Press Room Statistics*. [Online]. Available from: <http://www.facebook.com/press/info.php?statistics>. [Accessed: 17/05/2010].
- Fuchs, C., Hofkirchner, W., Schafranek, M., Raffl, C., Sandoval, M., & Bichler, R. (2010). Theoretical foundations of the web: cognition, communication, and co-operation. Towards an understanding of web 1.0, 2.0, 3.0. *Future Internet*, 2(1), 41-59.
- Glazer, R. (1991). Marketing in an information-intensive environment: strategic implications of knowledge as an asset. *Journal of Marketing*. 55(4). P.1-19.
- Glazer, R. (1993). Measuring the value of information: the information-intensive information. *IBM Systems Journal*. 32(1). P.99-110.

- Hemsley-Brown J.V. & Oplatka, I. (2006). Universities in a competitive global marketplace: a systematic review of the literature on higher education marketing. *International Journal of Public Sector Management*. 19 (4). P.316-338.
- Hoffman, D. L. & Novak, T.P. (1996). Marketing in Hypermedia Computer-Mediated Environments: Conceptual Foundations. *Journal of Marketing*. 60(3). P.50–68.
- Hourigan, T. & Murray, L. (2010). Using blogs to help language students to develop reflective learning strategies: towards a pedagogical framework. *Australian Journal of Educational Technology*. 26(2). P. 209-225
- Institute of International Education (IIE).(2009a). *AMERICANS STUDY ABROAD IN INCREASING NUMBERS*. [Online]. Available from: <http://opendoors.iienetwork.org/?p=150651>. [Accessed: 12/05/2010].
- Institute of International Education (IIE). (2009b). *RECORD NUMBERS OF INTERNATIONAL STUDENTS IN US HIGHER EDUCATION*. [Online]. Available from: <http://opendoors.iienetwork.org/?p=150649>. [Accessed: 15/05/2010].
- Kotler, P. & Fox, K. (1985). *Strategic Marketing for Educational Institutions*. Englewood Cliffs, New Jersey: Prentice-Hall]
- Kesim, A. & Agaoglu, E. (2007). A paradigm shift in distance education: Web 2.0 and social software. *TOJDE*. 8 (3). P.66-75
- Ketterl, M., Mertens, R., & Vornberger, O. (2008). Web Lectures and Web 2.0. In *Proceedings of the 2008 Tenth IEEE international Symposium on Multimedia*. December 15 - 17, 2008. Washington, DC: IEEE Computer Society. pp. 720-725.
- Kes-Erkul, A. & Erkul, R. (2009). Web 2.0 in the Process of e-participation: The Case of Organizing for America and the Obama Administration. *National Centre for Digital Government Working Paper Series*. 9(1). P.1-19.
- Kohli, A. K. & Jaworski, B. J. (1990). Market-Oriented: The Construct, Research Propositions, and Managerial Implications. *Journal of Marketing*. 54 (2). P.1-18.
- Kotler, P., Kartajaya, H. & Setiawan, I. (2010). *Marketing 3.0: From Products to Customers to the Human Spirit*. Hoboken, New Jersey: John Wiley & Sons
- Kierzkowski, A. et al. (1996). Marketing to the digital consumer. *The McKinsey Quarterly*. 3. P.5-21.
- Miller, P. (2005). *Web 2.0: Building the New Library*. [Online]. Available from: <http://www.ariadne.ac.uk/issue45/miller/>. [Accessed: 4/05/2010].

Miller, P. (2006). Coming together around Library 2.0: a focus for discussion and call to arms. *D-Lib Magazine*. [Online]. 12(4). Available from: <http://www.dlib.org/dlib/april06/miller/04miller.html>. [Accessed: 27/04/2010]

Murugesan, S. (2007). Understanding Web 2.0. *IEEE IT Professional*. 9 (4). P.34–41.

Morgan, R.F. (1996). An INTERNET Marketing Framework for the World Wide Web (WWW). *Journal of Marketing Management*. 12. P.757-775

NAFSA, Association of International Educators. (2009). *The Economic Benefits of International Education to the United States: A Statistical Analysis*. [Online]. Available from: <http://www.nafsa.org/publicpolicy/default.aspx?id=17174>. [Accessed: 4/05/2010]

Narver, J.C. & Slater, S. F. (1990). The Effect of a Market Orientation on Business Profitability. *Journal of Marketing*. 54(4). P.20-35.

Nielsen Company. (2009a). *The Global Online Media Landscape: Identifying opportunities in a challenging market*. [Online]. Available from: <http://blog.nielsen.com/nielsenwire/wp-content/uploads/2009/04/nielsen-online-global-lanscapefinal1.pdf>. [Accessed: 17/05/2010].

Nielsen Company. (2009b). *Global Faces and Networked Places: A Nielsen report on social networking's new global footprint*. [Online]. Available from: http://blog.nielsen.com/nielsenwire/wp-content/uploads/2009/03/nielsen_globalfaces_mar09.pdf. [Accessed: 14/04/ 2010].

O'Reilly, T. (2005). *What Is Web 2.0: Design Patterns and Business Models for the Next Generation of Software*. [Online]. Available from: <http://oreilly.com/web2/archive/what-is-web-20.html>. [Accessed: 12/03/2010]

O'Reilly, T. (2006). *Web 2.0 Compact Definition: Trying Again*. [Online]. Available from: <http://radar.oreilly.com/archives/2006/12/web-20-compact-definition-tryi.html>. [Accessed: 6/04/2010]

Pochoda, P. (2009). UP 2.0: Some Theses on the Future of Academic Publishing. *The journal of electronic publishing*. [Online]. 13(1). Available from <http://quod.lib.umich.edu/cgi/t/text/text-idx?c=jep;view=text;rgn=main;idno=3336451.0013.102>. [Accessed: 3/05/2010]

Scutter, S., Stupans, I., Sawyer, T., & King, S. (2010). How do students use podcasts to support learning? . *Australasian Journal of Educational Technology*, 62(2), 180-191.

- Swan, A. (2006). Overview of scholarly communication. In Jacobs, N. Ed. *Open Access: Key strategic, technical and economic aspects*. London: Chandos publishing
- Surowiecki, J. (2004). *The wisdom of crowds: Why the many are smarter than the few and how collective wisdom shapes business, economies, societies and nations*. New York: Doubleday.
- Sheth, J. N., Gardner, D. M. & Garrett, D. E. (1988). *Marketing Theory: Evolution and Evaluation*. Chichester: John Wiley & Sons
- Shirky, C. (2003). Social Software and the Politics of Groups Retrieved 20/07/2010, from http://shirky.com/writings/group_politics.html
- Thompson, J.B. (2005). *Books in the Digital Age: The Transformation of Academic and Higher Education Publishing in Britain and the United States*. Cambridge: Polity Press.
- Tuchinda, R., Szekely, P., & Knoblock. C. A. (2008). Building Mashups by Example. In *Proceedings of the 13th international Conference on intelligent User interfaces*. Gran Canaria, Spain, January 13 - 16, 2008. New York, NY: ACM. pp. 139-148
- UK Council for International Student Affairs (UKCISA). (2009). *Higher education statistics*. [Online]. Available from: http://www.ukcisa.org.uk/about/statistics_he.php#table8. [Accessed:14/04/2010].
- Varadarajan, R. & Yadav, M. S. (2009). Marketing Strategy in an Internet-Enabled Environment: A Retrospective on the First Ten Years of JIM and a Prospective on the Next Ten Years. *Journal of Interactive Marketing*. 23 (1). P. 11–22.
- Wigand, R. T., Benjamin, R. I., & Birkland, J. L. H. (2008). *Web 2.0 and beyond: implications for electronic commerce*. Paper presented at the Proceedings of the 10th international conference on Electronic commerce.
- Yan, L., Yang, J., & Wang, W. (2008). *Using Web 2.0 for Knowledge Management in Higher Education*. Paper presented at the International Symposium on Knowledge Acquisition and Modeling.
- Zuckerberg, M. (2010). Facebook reveals 'simplified' privacy changes. *BBC NEWS*. [Online]. Wednesday, 26 May 2010. Available from: <http://news.bbc.co.uk/1/hi/technology/10167143.stm> . [Accessed: 26/ May/2010]

Implementing the Process of Knowledge Sharing within Small Construction Consultancy Companies in Ireland

Rita Scully¹ and Farzad Khosrowshahi²

¹School of the Built Environment, Limerick Institute of Technology, Limerick, Ireland

²School of the Built Environment, University of Salford

Abstract:

Acquiring and retaining competitive advantage is vital for companies to remain in profitable business. Exploiting the advantages available through knowledge sharing (KS) is one way of acquiring a competitive advantage. In the Irish construction industry the majority of construction consultancy companies are small or micro with less than 50 staff members. For small companies working in a fragmented and knowledge intensive industry their ability to maximise their competitive advantage is vital to them being able to survive in the industry. These companies greatest asset is staff knowledge and professional experience. If they harness this asset they will work more efficiently and productively, enabling them to respond to the rapidly changing industry. The focus of the research is to investigate the cultural conditions that exist in small construction consultancy companies (SCCC) in Ireland and assess the extent of KS that is occurring in these companies. The research methodology applied is a blended approach which has generated both quantitative and qualitative results. The results indicate a good basis of staff trust and motivation and an open and inclusive culture. This atmosphere would form a good basis for strong KS strategy within these companies. The involvement of knowledge managers seems to be low. Further investigation is required to allow a fuller picture to be developed on the future of KS in SCCC in Ireland.

Keywords:

Construction Industry, Knowledge Management, Knowledge Sharing, Ireland

1. Introduction

The pressures of industry competition, technological advancements, business restructuring and amalgamation, and unstable economic conditions are combining to make it more important than ever for companies to learn and adapt for improved performance. Knowledge Management (KM) is one tool that companies can apply in developing this improved performance. (Drucker, 1994) noted that knowledge is the key determinant of a company's competitive advantage in this "new" or "knowledge-based" economy. As (Davenport and Grover, 2001) stated "*There are far too many knowledge workers dealing with too much knowledge for knowledge management to disappear.*"

Knowledge is becoming the main source of competitive advantage potential for companies working in turbulent environments and this knowledge is derived from the companies workers (Weldy, 2009). KS in a company is vital as it can contribute to knowledge application, innovation, and ultimately, a company's competitive advantage (Jackson et al., 2006). For the basis of knowledge growth to emerge in a company an effective KS process must be encouraged (Dixon, 2000) (Osterloh and Frey, 2000) and (Bock and Kim, 2002). The capacity of a company to innovate and improve depends of its ability to effectively share and exploit its intellectual capital (Egbu, 2004).

One aspects of any KM discussion is the assumption that there is knowledge to manage and that it is worth managing. Worth of knowledge will be determined by the specific shareholders involved at a specific point in time. Looking at KM from a commercial perspective, the knowledge to be managed must be perceived to have commercial worth or contribute to a company's complete advantage.

The construction industry is considered an information intensive industry; but it often lacks an integrated and a coordinated approach (Ingirige, 2005). The industry is based around a team structure. Because it is information intensive and predominately has a team structure effective KS within companies is vital. In early 2007 the output from the Irish construction industry peaked at 24 % of the Gross National Product (GNP). Employment in construction peaked in late 2006 at almost 13% of the workforce directly employed (D.K.M, 2009). (Egbu and Robinson, 2005) believe that construction organisations are now under more pressure due to the impact of

technology, increased competition and trying to maintain a highly skilled workforce. Since the onset of the construction industry contraction in Ireland, construction output is down almost 15 % of the country's GNP and direct employment has reduced by 23% (Q4 2009) and continues to fall (D.K.M, 2009). The triggers to KM that were noted in the construction industry in the United Kingdom by (Egbu, 2006) are equally valid to the Irish situation.

Construction consultancy in Ireland includes a wide variety of professional skills. Each is recognised as bringing a specialist skill and expertises to the process of project development. These specialists include Architects, Engineers, Quantity Surveyors, Project Managers, Developers and Estate Agents. There are a number of professional bodies who represent these professions some of which include the Royal Institute of Architects of Ireland, the Society of Chartered Surveyors (SCS) and the Institute of Engineers of Ireland. A professional is one who attempts to ensure the resources of the construction industry are utilised to the best advantage by providing the design, engineering, financial management and consultancy service to the client during the construction process. Clients have an increased expectation of the service offered by professionals and this coupled with greater competition both internally (from the profession) and externally has resulted in a challenge to their professional status (Davis et al., 2007). (Matzdorf et al., 1999) earlier described clients as becoming more critical, more knowledgeable, more selective – in one word, more demanding.

In Ireland the construction consultancy areas is predominated with micro and small companies. This type of structure represents difficulties when trying to instigate change in any form. In order to develop industry change in this environment the majority of the stakeholders in the industry need to engage in and persevere with the changes until a natural synergy evolves and assists the change in becoming standard industry practice. In 2004 the Construction Information Technology Alliance in Ireland (CITA) carried out a survey on behalf of the SCS. This survey highlighted that 77% of respondents felt KM training would be relevant to their organisation; 20% felt it would be very relevant. From this survey construction consultants appear to appreciate the potential for KM but do not have the skills available to apply it to their organisations. The issue to be investigated is the ability of a company to identify and remove barriers to KS and replace them with a positive KS environment within a

company to stimulate the level of KS occurring in that company and in the broader industry.

The core aim of this research is to investigate the issues that contribute to or detract from the KS behaviour within a SCCC in Ireland. To this end, it is necessary to understand KS in a company context. The research has demonstrated that trust and motivation is at a reasonable level to share knowledge but further support and engagement is required from senior management in appointing knowledge managers.

2. Research Justification

Companies deal with the issues associated with running a SCCC on a daily basis. Their managers and directors are generally working consultants within the company. The gap between academic research and its application in business is ever increasing. Company managers and staff have little time to research and adapt methods of KS from other industries and apply and monitor these in their own practices.

There have been no systematic studies to investigate the issues that influence KS in SCCC this research will be the first in Ireland. Developing structured proposals for KS in SCCC in Ireland will enhance and accelerate the development of KS. Extensive academic literature exists in the theoretical application of KS in companies but practical methods to apply KS methods to SCCC have been ad-hoc and piece meal.

3. Knowledge Sharing

KS in a company is vital as it can contribute to knowledge application, innovation, and ultimately, a company's competitive advantage (Davenport and Prusak, 1998), (Babcock, 2004), (Jackson et al., 2006). Some 80 percent of useful knowledge is tacit and cannot be written down. KM strategies need to recognise and accept this (Sheehan et al., 2005). For the shared knowledge to retain maximum value to the company it must retail or be shared in ways that encapsulate the personal experience and qualities that elevate the information and data to knowledge. (Nonaka and Takeuchi, 1995) would also concur with this view. By sharing knowledge it allows the learning curve for the recipient to be accelerated. If this is happening as part of a

company process or system it will translate into the company learning at an accelerated rate.

Under what circumstances do people share knowledge and what detracts from the knowledge sharing behaviour?

The transfer and sharing of knowledge is a key factor in a knowledge management system. The terms knowledge sharing, knowledge transfer and knowledge flow are often used interchangeably to describe the knowledge movement that occurs within a company. Knowledge can be shared at individual or company level (Ipe, 2003). If we accept the view that staff is a company's primary asset then it is the individual's knowledge that must first be extracted before it can be applied and shared. KS provides the link between the individual staff member and the company. It attempts to transfer the knowledge residing in the staff member to the company level (Hendriks, 1999). KS is a dynamic process affected by factors that exist at company, team and individual level (Davenport and Prusak, 1998); (Andrews and Delahay, 2000).

4. Motivation

Why people are motivated to share their knowledge needs to be understood so that the conditions that trigger or support that motivation can be enhanced to encourage more staff to share their knowledge. Staff may think that possessing valuable or unique knowledge allows them to retain a competitive advantage over other staff (Bock and Kim, 2002). But the hoarding of knowledge by staff will reduce a company's potential competitive advantage. KS will be more likely if individuals are rewarded (Newell et al., 2002). For successful KS to develop a grass root desire must exist so employees contribute to and benefit from their company's intellectual resources (Hauschild et al., 2001). In order to build a knowledge-based enterprise, incentive systems should be focused on criteria such as KS and contribution, teamwork, creativity and innovative solutions (Wong, 2005).

5. Culture

Culture is a very wide concept; one cultural aspect which is crucial for KS is collaboration. This is because KS requires individuals to come together to interact and exchange ideas (Wong, 2005). Like (Robinson et al., 2001), (Dent and Montague, 2004), (Payne and Sheehan, 2004); and (Egbu, 2006) also identify the cultural barriers that exist and can hinder the implementation of a successful KS strategy and learning approaches. A study carried out by (Peng and Akutsu, 2001) showed that cultural factors can have an impact on the knowledge transfer process. (Bollinger and Smith, 2001) believe that if a supportive organisational culture and top management support are not in place, there will be little incentive for staff to share knowledge. (Bandura, 1986) earlier reached this assertion, stating staff may decide not to demonstrate particular behaviours if they believe it will not improve their status within the company. (Robinson et al., 2001) concludes that a lack of top management support can hamper the success of a KS strategy this view is supported by (Al-Ghassani et al., 2002) and (Robinson et al., 2005). (Carrillo et al., 2000) identify the need for leadership in KS which will help motivate others to get involved. A champion will ensure that KS is accepted by all in the company and ensure that any problems are highlighted in the early stages and rectified (Robinson et al., 2005) (Harrigan, 2005) support the importance of a champion or knowledge manager within companies. Knowledge champion or leadership is based on relationship building, there is a need to constantly network, listen and act on messages received from staff. Knowledge champions encourage staff to contribute and share knowledge through ongoing contact, relationship building, recognition of staff contributions, and providing opportunities for growth and development in the company (Singh, 2008).

(Wyer et al., 2000) outlined some issues, which may constrain change in company culture; the commitment of top managers, top managers may constrain the progress by being reluctant to have open management approaches and empowering staff. (Hamlin et al., 2001) six-step model for the successful implementation of change management presents a comprehensive solution. A key driver in the implementation of change is that ownership, commitment and involvement to the new strategy must be secured throughout the company, including that of top-management.

6. Trust

Without a high degree of trust in companies, staff will be sceptical about the intentions and behaviours of others and thus, they may withhold their knowledge. Thus a culture of collaboration and trust will go hand in hand. (Sharkie, 2005) purports that restructuring and downsizing of companies has adversely affected the traditional employment relationship. As a result, “the psychological contract existing under the lifetime employment model has been replaced with a strong element of precariousness in the employment relationship (which adversely) impacts the level of trust in organizations..” (Sharkie, 2005), p38). (Hendriks, 1999) and (Ardichvili et al., 2003) concurred that no matter how motivated staff are, they do not share knowledge with those they do not trust. (Levin and Cross, 2004) found that the level of trust affects not only the sharers but the seekers of knowledge too. (Andrews and Delahay, 2000) claim that when there is trust between individuals, they are more likely to take note of and receive knowledge in addition to providing worthwhile knowledge in return.

7. Research Methodology

7.1. Research Philosophies

From Ontological and Epistemological perspective the research philosophy applied tended towards the constructivist end of ontology and the interpretivist’s end of epistemology. Because of the nature or trying to study practical KS in companies cognisance needs to be taken of the complex and interdependent nature of the company culture, staff mix, work pressures and work practices that exist. This philosophical stance resulted in the adoption of inductive reasoning being applied to the research approach to be applied and the selection, design and development of the research tools to be applied which in turn impacted on the nature of data collection.

7.2. Data Collection

Quantitative research strategy will support deductive reasoning and the positivist range of the epistemologists’ philosophy. Qualitative data collected is soft data designed to develop an in-depth understanding and explanation for people’s

behaviour, motivations and attitudes. (Carson et al., 2001, Naoum, 2006). This research strategy will support inductive reasoning and the interperativists range of the epistemologists philosophy.

7.3. Research Approach and Strategy

A blended approach was applied in the research. (Creswell, 1994) referred to this as mixed method research. (Van der Velde et al., 2004) describe this method as “method triangulation”. The initial questionnaires providing the objective quantified industry statistics and standards and the Likert Scale type questions allowed a range of responses. In each question space was available to insert “Other” responses or answers but this was not used by any of the responders. (Hart, 2005) sets out a framework summarising the forces to consider when selecting appropriate research tools that can be applied to gather the relevant data. The questionnaires were structured to give both quantitative and qualitative data results. This would allow an overall picture of the current position of KS within SCCC in Ireland to be formed but also provide us with information of the staffs’ attitudes towards KS within their practices. The questions focused on:

What are levels of involvement of Knowledge managers

What are staffs impression of company culture

What levels of trust exist for sharing knowledge

What levels of motivation are there within staff to share knowledge

8. Piloting Stage

The literature review helped to gain a better understanding of existing theory, practice and current development on the area of research. The review provided the basis for the development of a suitable research aim and research objectives. (Saunders et al., 2002) the review of literature formed the basis of designing the questionnaire. The stages consisted of initial design, redesign as necessary, pilot survey, feedback and final design.

9. Selection of Data Source

The research will focus on KS in SCCC's in Ireland. Once the current position is known the best methods to implement a long term KS strategy for a company can be proposed. The majority of Construction Consultancy Companies within Ireland are small with less than 50 employees or micro with less than 10 employees (Commission, 2005). To date 95 questionnaires have been distributed with 43 being returned. The questionnaires were distributed to a cross-section of SCCC in Ireland.

10. Findings and Analysis

The following are an analysis of the 43 responses received to date. Despite the companies having diverse professional services their basic structure is similar and they all interact with each other and within the same industry. All have a high dependency of staff skills to fulfill their professional services and all work in hierarchal team structure. By having a broad spread of feedback from all SCCC's in Ireland a more comprehensive understanding of the issues can be achieved. Table 1 displays the diverse range of SCCC that have currently contributed their expertise to this research.

Table 1. Questionnaire Return Rate

Construction Consultancy Area	Nr.	Construction Consultancy Area	Nr.
Auctioneer/Estate Agent	1	Project Management	8
Building Contractors/Developers	10	Quantity Surveyors	15
Engineers	3	General Practice Surveyor	1
Other	3		

The current literature and academic research highlights the importance of having a knowledge manager or staff member responsible for KS. This aspect of KS in SCCC was addressed with a set of questions on the level of specialised staff involvement and responsibility for KS that exists within companies. As Table 2 highlights the majority

of the companies do not have specific staff responsible for the development of a KS development program within their companies.

Senior management are involved “to some extent” in the various KS activities noted. Just as there are low levels of appointment of knowledge managers by senior management likewise there is low level of involvement by senior management in knowledge management and KS issues. The results point to weak proactive engagement by senior management with the practical aspects of KS. Having specialist staff appointed in KS shows all staff members that this is an area that senior management value and consider worthy of investment. It will show senior management’s commitment to the long-term support and backing that is required to ensure successful KM and a vibrant KS culture develops.

Table 2. Senior Management Involvement

Data Results	Dominant Answer selected	%
Does the company have		
A Knowledge Manager	No	55
An employee with responsibility for developing knowledge sharing methods or systems	No/To Little Extent	64
Are Senior Management involved in		
Identifying knowledge sources	To some extent	44
Contributing to company knowledge	To some extent	40
Reviewing and distributing new knowledge	To some extent	37

Despite low levels of senior management engagement with KS, staff motivation towards sharing knowledge appears to be good. Staff members seem to be open to and willing to share their knowledge. This is a positive situation; it would be hoped that with greater commitment from senior management significant improvements would be seen in motivation levels among staff to share their knowledge. In the

questionnaire a number of statements were presented and responders were asked to note their level of agreement or disagreement. The statements noted below related to company culture and trust. These two concepts are closely linked to motivation. Reasonable levels of trust and indications of a supportive culture for staff wishing to share knowledge and engage in an inclusive and open work culture.

Table 3. Staff Trust and Motivation

Data Results	Dominant Answer selected	%
I feel free to voice my knowledge/experience in work	Agree	49
There is staff openness to knowledge sharing	Agree	51
I trust my work colleagues	Agree	49
I trust the company managers	Agree	42
Teams work effectively together	Agree	53
Motivation – within staff	Good	47

For KS to become integrated into the majority of SCCC in Ireland there needs to be engagement in a number of areas which are interdependent. All areas need to be developed in tangent so that a synergy will evolve and the benefits gained in one area will support the development of another area.

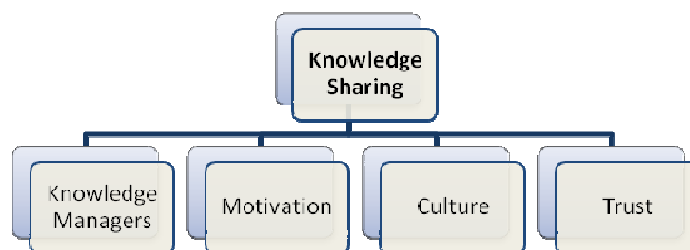

Figure 1. Knowledge Sharing Process

Table 4. Towards implementing the Process of Knowledge Sharing

Target – Full Knowledge Sharing		Current Position – Towards Full KS	
Area	Method	Current Rating	Future Action
Knowledge Managers Involvement	Appointment of Knowledge Managers	None - Poor	Higher involvement of knowledge managers
	Management involvement	Poor - Fair	Greater management involvement required
Motivation	Understanding staff individual needs for the good of the company	Fair - Good	Engage in targeted achievable goal towards KS
Culture	Success of the team valued	Fair - Good	Staff advancement due to company/team commitment
Trust	Open supportive environment	Fair - Good	Build on existing basis Show companies commitment to staff

Further research that will be important will be addressing how knowledge is transferred and applied. Understanding how learning moves from an individual to a company level and how this occurs within SCCC's.

11. Conclusion

This research has shown the current situation relating to KS within SCCC in Ireland. With reference to current literature and recommend factors for good KS the results from the research show low senior management commitment and low levels of knowledge managers' involvement.

One basic step that is widely supported by the literature is to develop a climate of trust, motivation and support. A few people hoarding information for their own advancement or benefit will inhibit overall company performance.

The research undertaken has shown staff motivation levels in Irish SCCC's are good, there is potential to increase the activity that is currently taking place but there is a strong foundation on which to build future KS activities. As shown in the literature culture, trust and motivation are strongly linked and the questionnaire results support this with very similar responses correlating across these three areas with staff. It is encouraging that the existing company culture is typically good and positive towards KS initiatives.

12. References

- Al-Ghassani, A. M., Kamara, J. M., Anumba, C. J. and Carrillo, P. M. (2002). *A tool for developing knowledge management strategies. ICT for Knowledge Management in Construction* 7(Special). <http://www.itcon.org/2002/5> (last accessed 23.03.08).
- Andrews, K., M and Delahay, B., L (2000). "Influences on knowledge processes in organizational learning: The psychological jilter." *Journal of Management Studies* 37: 797-810.
- Ardichvili, A., Page, V. and Wentling, T. (2003). "Motivation and barriers to participation in virtual knowledge-sharing communities of practice." *Journal of Knowledge Management* 7(1): 64-77.
- Babcock, P. (2004). "Shedding light on knowledge management." *HR Magazine* 49(5): 46-50.
- Bandura, A. (1986) *Foundations of Thought and Action*, Englewood Cliffs, New Jersey, Prentice Hall
- Bock, G. W. and Kim, Y. G. (2002). "Breaking the myths of rewards: an exploratory study of attitudes about knowledge sharing." *Information Resource Management Journal* 15(2): 14-21.
- Bollinger, A. S. and Smith, R. D. (2001). "Managing organisational knowledge as a strategic asset." *Journal of Knowledge Management* 5(1): 8-18.
- Carrillo, P. M., Robinson, H., Al-Ghassani, A. M. and Anumba, C. J. (2000). "Knowledge management in UK construction: Strategies, resources and barriers. ." *Project Management Journal* 35(1): 46-56.
- Carson, D., Gilmore, A. and Kjell, G. (2001) *Qualitative Marketing Research*, London, Sage Publications.

- Commission, T. E. (2005) *The New SME Definition*. Enterprise and Industry Publications.
- Creswell, J. W. (1994) *Research Design: Qualitative and Quantitative Approaches*, London, Sage Publications.
- D.K.M (2009) *Construction Industry Indicators Issue 17.17*: 11. DKM Economic Consultants, Department of Finance.
- Davenport, T., H and Grover, V. (2001). "Special Issue: Knowledge Management." *Journal of Management Information Systems* **18**(1): 3-4.
- Davenport, T. H. and Prusak, L. (1998) *Working knowledge: How organisations manage what they know*, Cambridge, Harvard Business School Press, .
- Davis, R., Watson, P. and Man, C. L. (2007) Knowledge Management For The Quantity Surveying Profession, *FIG Working Week 2007*, 16. Hong Kong SAR, China
- Dent, R. J. and Montague, K. N. (2004) Benchmarking knowledge management practice in construction. London, *CIRIA Report* 620.
- Dixon, N., M (2000) *Common Knowledge*, Boston, Harvard.
- Drucker, P. F. (1994). "The age of social transformation." *The Atlantic Monthly* November: 53-80.
- Egbu, C. (2004). "Managing knowledge and intellectual capital for improved organisational innovations in the construction industry: an examination of critical success factors." *Engineering, Construction and Architectural Management* **11**(5): 301-315.
- Egbu, C. (2006). "Knowledge production and capabilities - their importance and challenges for construction organisations in China." *Journal of Technology Management in China* **1**(3): 304-321.
- Egbu, C. and Robinson, H. (2005) Construction as a knowledge-based industry. IN ANUMBA, C. J., EGBU, C. and CARRILLO, P. M. (Eds.) *Knowledge management in construction*. 31-49. Oxford, Blackwell Publishing.
- Hamlin, B., Keep, J. and Ash, K. (2001) *Organizational Change and Development: A Reflective Guide for Managers, Trainers and Developers*, London, Financial Times and Prentice Hall.
- Harrigan, E. (2005). "Tobin builds knowledge infrastructure." *The Engineers Journal* **59**(6).
- Hart, C. (2005) *Doing your Masters Dissertation*, London, SAGE.

- Hauschild, S., Licht, T. and Stein, W. (2001). "Creating a knowledge culture." *The McKinsey Quarterly* **1**: 74-81.
- Hendriks (1999). "Why share knowledge? The influence of ICT on the motivation for knowledge sharing." *Knowledge and Process Management* [<http://www3.interscience.wiley.com/cgi-bin/jhome/6242>](http://www3.interscience.wiley.com/cgi-bin/jhome/6242), **6**(2): 91-100.
- Ingririge, B. (2005) *Impact of IT Applications on Construction Performance*, . MSc IT Management in Construction, Module: IT Implementation and Innovation. University of Salford.
- Ipe, M. (2003). "Knowledge Sharing in Organizations: A Conceptual Framework." *Human Resource Development Review* **2**(4): 337-359.
- Jackson, S. E., Chuang, C. H., Harden, E. E., Jiang, Y. and Joseph, J. M. (2006). "Toward developing human resource management systems for knowledge-intensive teamwork." *Research in Personnel and Human Resources Management* **25**: 27-70.
- Levin, D. and Cross, R. (2004). "The Strength of Weak Ties You Can Trust: The Mediating Role of Trust in Effective Knowledge Transfer." *Management Science* **50**(11).
- Matzdorf, F., Price, I. and Green, M. (1999). "Barriers to organisational learning in the chartered surveying profession." *Property Management* **18**(2): 21.
- Naoum, S. G. (2006) *Dissertation Research and Writing for Construction Students*. London, Elsevier.
- Newell, S., Robertson, M., Scarbrough, H. and Swan, J. (2002) *Managing Knowledge Work*, Wales-Great Britain, Palgrave.
- Nonaka, I. and Takeuchi, H. (1995) *The Knowledge Creating Company*, New York, Oxford University Press
- Osterloh, M. and Frey, B. (2000). "Motivation, knowledge transfer, and organizational forms." *Organization Science* **11**(5): 538-550.
- Payne, J. and Sheehan, T. (2004) *Demystifying knowledge management: A best practice guide for the construction industry*. Constructing Excellence Publication.
- Peng, K. and Akutsu, S. (2001) *A Mentality Theory of Knowledge Creation and Transfer*. IN NONAKA, I. and TEECE, D. (Eds.) *Managing Industrial Knowledge*. London, SAGE.
- Robinson, H. S., Carrillo, P. M., Anumba, C. J. and Al-Ghassani, A. M. (2001) Perceptions and barriers in implementing knowledge management strategies in large construction organisations. IN KELLY, J. and HUNTER, K. (Eds.) *Construction and*

Building Research (COBRA) Conference. Glasgow Caledonian University, RICS Foundation.

Robinson, H. S., Carrillo, P. M., Anumba, C. J. and Al-Ghassani, A. M. (2005). "Knowledge management practices in large construction organisations " *Engineering, Construction and Architectural Management* **12**(5): 431-445.

Saunders, M. N. K., Lewis, P. and Thornhill, A. (2002) *Research Methods for Business Students*, London, Financial Times Prentice Hall.

Sharkie, R. (2005). "Precariousness under the new psychological contract: The effect on trust and the willingness to converse and share knowledge." *Knowledge Management Research & Practice* **3**(1): 37-44.

Sheehan, T., Poole, D., Lyttle, I. and Egbu, C. (2005) Strategies and business case for knowledge management. IN ANUMBA, C. J., EGBU, C. and CARRILLO, P. M. (Eds.) *Knowledge management in construction*. 50-64. Oxford, Blackwell Publishing.

Singh, S. K. (2008). "Role of leadership in knowledge management: a study." *Journal of Knowledge Management* **12**(4): 12.

Van Der Velde, M., Jansen, P. and Anderson, N. (2004) *Guide to Management Research Methods*, England, Blackwell Publishing.

Weldy, T. G. (2009). "Learning organization and transfer: strategies for improving performance." *The Learning Organization* **16**(1): 10.

Wong (2005). "Critical success factors for implementing knowledge management in small and medium enterprises, ." *Industrial Management & Data Systems* **105**(3): 261-279.

Wyer, P., Mason, J. and Theodorakopoulos, N. (2000). "Small business development and the learning organization." *International Journal of Entrepreneurial Behaviour and Research* **6**(4): 20.

The Efficiency of Libyan Commercial Banks in the Context of Libyan WTO Accession

Saleh R. Abida and Gianluigi Giorgioni, *Liverpool John Moor University*

Abstract

This paper aimed at comparing the level of efficiency of Libyan commercial Banks over the period 1999-2007 (as an indicator of the ability of Libyan banks to compete with other banks as Libya become a full member of the WTO) against the efficiency of banks operating in GCC countries. The efficiency level was calculated using the input-oriented Data Envelopment Analysis (DEA) technique, under both Constant Return to Scale (CRS) and Variable Return to Scale (VRS) assumptions.

Surprisingly, for a sample inclusive of both Libyan and GCCs banks, the results reveal that the mean efficiency score of the Libyan banking industry is not dissimilar to, if not higher than, the GCC country's mean. The analysis was repeated without Libya but the relative ranking of the GCC countries remained the same. The full explanation for the results for Libya surely requires further empirical work, in terms of evaluating the impact of nation-specific characteristics in influencing the results. A further interesting finding is that efficiency scores have declined over the sample period on average, offering limited support to a positive impact of both membership of the WTO and successive reforms of the banking sector in the countries under examination. These results indicate the need for further research in this area.

1. Introduction

Libya has been recently trying to both diversify the economy to reduce its dependency upon oil and to become more integrated into the international economic, political and financial community, for instance by becoming a member of the World Trade Organisation (WTO), for which it has gained the status of observer in 2004. One of the sectors identified as very important is the service sector, in particular the banking sector. When Libya becomes a full member of the WTO, domestic banks will have to completely open up to competition from foreign banks and other overseas financial institutions. The ability of Libyan banks to meet the challenges and conditions of

joining to the WTO depends on how efficiently they are run. To provide some tentative evidence on how efficient Libyan banks are, their efficiency will be empirically evaluated by using Data Envelopment Analysis (DEA) method and compared to the efficiency of banks located in the [Gulf Cooperation Council \(GCC\)](#), which have already gained membership of the WTO. The efficiency of Libyan and GCC banks will be calculated for nine years (over the period 1999-2007).

Table (1) Date of Membership of WTO

Country	Date of membership
Bahrain, Kingdom	1 January 1995
Kuwait	1 January 1995
Saudi Arabia	11 December 2005
United Arab Emirates	10 April 1996
Qatar	13 January 1996
Oman	November 2000

Source: (WTO, 2010)

The rest of the paper is divided into five parts. Section 2 reviews some of the relevant literature, while section three examines the methodology for evaluating the efficiency and justifies the approach used and the type of international comparisons efficiency. This includes a brief definition of banking efficiency and its measurement focusing on the DEA method, sources of data collection and advantages and disadvantages of the DEA method. The final section, evaluates and analyses the efficiency of the banks in Libya and GCC countries, presents the results, and summarises main conclusions.

2. Brief Literature Review of Banks Efficiency in Libya and GCC Countries

Few studies have focused on banks in general and banks efficiency in specific in Libya. For example, (Alhasia, 1985), (Abida and Fayad, 2003) and (Hufbauer and Brunel, 2008). However, these studies have mainly relied on financial ratios to measure the efficiency of Libyan banks and concluded that the Libyan banking sector was inefficient. The most important study to evaluate bank efficiency in the context of Libya was written by Alwdan, (2005). The study used DEA method. The aim of the study was to measure and to explain the variations in the performance of commercial banks (five large state owned banks) in Libya during the initial stages of recent

banking reforms. The main finding of the study indicated that reforms had little impact. The study was very useful in identifying the changes in efficiency and its evolution in Libyan banks during the period of 1980-2000 for five large state owned banks.

Al-Faraj et al. (2006) used DEA method to investigate the level of efficiency of the Saudi commercial banking sector. The research sample consisted of nine Saudi commercial banks for the year 2002. The analysis was repeated under different assumptions of scale of efficiency. The study reveals that the mean of efficiency score of the Saudi banks sector is higher than the world's mean. The study recommended that Saudi banks should continue their efforts of adapting new technologies and providing more services in order to sustain competitive advantages as Saudi Arabia continues to reform the banking sector.

Mostafa (2007a) used DEA to measure the efficiency levels of the top 100 Arab banks, while Mostafa (2007b) used DEA to measure the relative efficiency of the top 50 Gulf Cooperation Council (GCC) banks. In both cases cross-sectional data for the year 2005 were used to conduct the analysis. The results indicated that the performance of several banks was sub-optimal, suggesting the potential for significant improvement in both groups of countries. The studies highlight the importance of encouraging increased efficiency throughout the banking sector in the Arab countries and in the GCCs.

Al-Muharami (2008) used the DEA technique to estimate technical, pure technical and scale efficiency, using an input orientation of banks in the GCC countries banks for the period 1993-2002. The sample included 52 privately held and domestically owned fully licensed commercial and Islamic banks. The most important finding of the study is that smaller banks have superior performance in terms of overall technical efficiency than larger ones. Due to the fact that small banks generally operate under increasing return to scale, growth of small banks consolidation in the market to a medium size is desirable and should enhance the efficiency of the whole banking sector.

3. Methodology, Sample, Data Sources and Variables

3.1. Methodology

In this paper a non-parametric approach will be used: the Data Envelopment Analysis (DEA)⁷. Since the original study of Data Envelopment Analysis (DEA) by Charnes et al (1978), there has been rapid and continuous growth in using of DEA technique, especially in developed countries. As a result, a considerable amount of published research has appeared, with a significant portion focused on DEA applications of efficiency and productivity in both public and private sector.⁸

In this study, the performance of banks, not bank branches, is assessed, viewing them as intermediaries. Furthermore, the efficiency is measured over several years with a common efficient frontier (all countries included) or nation-specific efficient frontiers. Libya will be included in and omitted from the common frontier to provide robustness to the results.

The main advantage of DEA is that it does not require a specific functional to determine the most efficient DMUs, and so capture the interplay between various inputs and outputs of different dimension (Avkiran, 1999a). Furthermore, the DEA method is particularly suitable to working with limited sample sizes (Evanoff and Israilevich 1991). On the other hand, the DEA's major shortcoming is that the frontier may be sensitive to extreme observations and measurement errors (the basic assumption is that random errors do not exist and that all deviations from the frontier indicate inefficiency).

Berger (2007) reviewed the findings of over 100 studies that compared bank efficiencies across different countries. He divided these studies in three types: (1) comparisons of bank efficiencies in different nations based on the use of a common efficient frontier (CEF), (2) comparisons of bank efficiencies in different nations

⁷ Alternative methods, not surveyed here for reasons of space are financial ratios used in several studies (see for instance, (Murinde and Ryan, 2002) and (Tarawneh, 2006)) and parametric approaches, that require the specification of a cost or production function. The parametric approach also includes the specification and econometric estimation of production functions.

⁸ Emrouznejad et al (2008) maintain an extensive bibliography of DEA research covering theoretical developments as well as empirical applications from 1978 to 2007. They have identified more than 4,000 research articles published in journals or book chapters. Banking, education (including higher education), health care, and hospital efficiency were found to be the most popular areas of study. These studies have used a variety of inputs and outputs in their analysis.

using nation-specific frontiers (NSF), and (3) comparisons of efficiencies of foreign-owned versus domestically owned banks within the same nation using the same nation-specific frontier (FNSF). All three types of comparisons yield interesting findings, and also have limitations. As for the type of international comparison, the study will use the first and the second type of international comparison mentioned by Berger (2007).

3.2. Definition of the Sample and Data Sources

The countries studied in this paper are: Libya, Saudi Arabia, Kuwait, United Arab Emirates, Oman, Bahrain and Qatar. The choice of the above countries is based on the nature of economies of these countries. All of them are classified as petroleum countries and the banking sectors in these countries are still supported by the government in a direct or indirect way. Data used in this study are collected from balance sheets and income statements of banks, their web pages in the internet, annual central banks reports and also from the Bankscope database. Table 2 below shows the description of the sample used in this study. It can be seen that despite the efforts to collect data, there are few missing observations for some of the countries.

Table (2) Sample Used for the Empirical Analysis

	Total	Libya	Saudi Arabia	Kuwait	United Arab Emirate	Qatar	Bahrain	Oman
Number of commercial banks	61	6	9	6	15	7	10	8
Percentage	100%	9%	14.8	9%	24.6%	11.5%	16.4%	13.1%
Number of observations	2004							
Observations by year								
1999	220	20	36	24	56	20	32	32
2000	224	20	36	24	60	20	36	28
2001	220	20	36	24	60	24	32	24
2002	216	24	36	24	60	24	28	20
2003	220	24	36	24	60	24	32	20
2004	224	24	36	24	60	24	36	20
2005	228	24	36	24	60	24	40	20
2006	220	24	36	24	56	20	40	20
2007	232	20	36	24	60	28	40	24

It is noticed that DEA is sensitive to the number of variables. In other words, as the number of variables increases, the ability to discriminate between efficient and

inefficient DMUs decreases (Smith, 1997). Thus to protect the discriminatory power of DEA, the number of inputs and outputs should be kept at a sensible level. Although there is no consensus of the appropriate sample size, several researchers like Avkiran (1999b) suggested a general rule that the product of inputs and outputs should be less than the sample size to discriminate between the efficient and inefficient banks. Dyson et al. (2001) suggested that the number of observations should be at least twice the product of the number of inputs and outputs. Avkiran (2002) suggests an additional rule of thumb- that a sample is large enough if the number of fully efficient DMUs is not more than one third of the sample. However, Raab and Lichty (2002) suggested another rule of thumb, that the minimum number of DMUs should be greater than three times the number of inputs plus outputs. In this study, with a total of two inputs and two outputs, a good minimum set would be 13 DMUs. In reality the sample contains 61 DMUs (banks) ranging from 6 to 15 banks per country and 2004 observations. Therefore, this study's sample size satisfies the requirement to run a robust analysis using both common efficient frontier and nation-specific frontier.

3.3. Inputs and Outputs Variables

Following Berger et al (1997) and Avkiran (2000) and in the context of the countries of the sample (Alwdan, 2005), (Al-Muharrami, 2008), (Al-Faraj et al, 2006), (Ramanathan, 2007) the selection of inputs and outputs in this study is based on intermediation approach that views banks as financial intermediaries whose primary business is to borrow funds from depositors and lend them to others for profit. In this approach loans represent outputs, whereas the various costs such as interest expenses, labour, capital, and operating costs represent inputs⁹. The bank's inputs are interest expenses (IE) and non interest expenses (OE). Interest expenses (IE) are the sum of interests paid on all liabilities and thus represent special commission expenses. Non-interest expenses (OE) include salaries and employees' benefits, expenses associated with rents and premises, depreciation and other general and administrative expenses. The bank's outputs are net interest income (NII) and non interest income (OI). Net interest income is the difference among interest income and interest expense. Interest

⁹ The second approach is the production approach, which considers banks as institutions that use capital and labour to produce loans and deposit account services. Consequently, accounts and transactions represent the outputs for these banks, whereas labour, capital and operating costs represent their inputs (Yue, 1992).

income is the sum of interest and fees gained on all bank's assets including special commission income and realised gains on investments. Non-interest income includes the income from source differ than interest. For instance, fees from services, exchange income, trading income, dividend income and other operating income.

4. Empirical Results

The collected data were analysed using Professional Software (DEAP 2.1 Computer programme) developed by Tim Coelli (1996). This program is used to construct DEA frontiers for the calculation of technical and cost efficiencies and also for the calculation of Malmquist TFP Indices.

The input minimisation DEA model was run under both constant return to scale (CRS) and variable return to scale (VRS) assumptions, with the DEA efficiency scores interpreted as a measure of how much each bank could reduce the use of its inputs without reducing output if it were as technically efficient¹⁰. In the context of DEA, there are two assumptions with respect to modelling banks behaviour, constant return to scale (CRS) and variable return to scale (VRS). The former assumption (CRS) is a common assumption in DEA analysis and is valid only when all decision making units (DMUs) or banks are operating at optimal scale. However, banks may not be operating at optimal scale since factors like imperfect competition, constrains to finance, exist. Also the (CRS) is more suitable with small samples. It compares each unit against all other units, regardless of their size. The alternative assumption, variable returns to scale (VRS), compares each unit only against other units of similar size, instead of against all other units. As such, an assumption of variable returns to scale is more suitable for large samples. These two assumptions have been used in this study to benefit from the advantages of each one. The results of application of DEA using nation a common efficient frontier (CEF) with and without Libyan banks over the period 1999-2007 are presented in table 3, while results of application of DEA by countries over the sample period 1999-2007 using both common and nation specific efficient frontier (NSF) are presented in Table 4.

¹⁰ The opposite is output maximisation where the model estimates how much output can be increased given the current level of inputs. Although the choice of orientation would not have a major effect on efficiency estimations since both approaches would lead to the same efficiency frontier (i.e. the same efficient DMUs (best performers) would be identified by both methods), the ranking of inefficient DMUs may change (Casu and Molyneux, 2003).

The average efficiency scores have been calculated as geometric means of the DEA scores of individual banks. For example, the average CRS efficiency score of the banks in Saudi Arabia is calculated as the geometric mean of the CRS efficiency scores of the nine banks of Saudi Arabia. The sample average is calculated as the geometric mean of the CRS, VRS and Scale efficiency scores of all the 61 banks.

As can be seen from table 3, the efficiencies scores of the entire sample under CRS have fluctuated and there is no a clear indication that the entire score efficiencies of sample has been improving gradually over the sample period.

The empirical results suggest that over the sample period, both PTE and SE measures show a great variation and the banking sectors of the sample did not achieve sustained efficiency gains.

Table (3) Sample with GCC Countries and Libya (Common Efficient Frontier)
Overall Yearly Average Technical, Pure Technical and Scale Efficiency

YEAR	TE (CRS scores)		P.T.E (VRS scores)		S.E	
	With Libya	Without Libya	With Libya	Without Libya	With Libya	Without Libya
1999	0.65	0.65	0.79	0.78	0.86	0.85
2000	0.64	0.72	0.75	0.82	0.88	0.88
2001	0.69	0.77	0.79	0.85	0.88	0.91
2002	0.74	0.77	0.84	0.85	0.88	0.90
2003	0.67	0.79	0.76	0.83	0.88	0.95
2004	0.46	0.49	0.67	0.71	0.70	0.70
2005	0.67	0.67	0.74	0.74	0.92	0.92
2006	0.60	0.63	0.75	0.76	0.80	0.83
2007	0.50	0.57	0.73	0.74	0.71	0.78

Notes: TE=Technical efficiency; PTE=Pure technical efficiency; CRS=Constant Return to Scale; VRS=Variable return to scale; SE=Scale efficiency.

It is noticed that there was a sharp reduction in mean efficiency scores during the years, 2004 and 2007 (with and without Libya). The reason behind the drop in mean efficiency score in 2004 and 2007 might be the reductions in interest rates, which was implemented by the Gulf countries to follow the drop in world interest rate. The GCC fix their currencies to US\$. They reduced their interest rate to keep the stability of their currencies (AMF, 2008) and (AMF, 2005).The reduction in interest rate has affected interest income. Therefore, the efficiency has been affected.

However, when VRS is assumed the average efficiency scores seems to be higher than the case of the CRS assumption and, as expected, a greater number of banks seem efficient under the VRS assumption (Banker et al., 1984). It is noticed that all

efficiency scores sample has increased including the years 2004 and 2007. However, the score of efficiencies of these years were still lower than other score efficiencies over the sample period. Furthermore, there is no clear evidence that efficiency score steadily increased over the period of study. Therefore, many changes and fluctuation under the two assumptions over the period of study. The correlation coefficient between the efficiency ranking derived from CRS and VRS analyses is 0.86. The positive and strong correlation indicates that the rank of each bank derived from applying the two approaches is similar. This implies that the choice of methodology has no significant impact on the estimated mean efficiency scores.

Regarding the efficiency scores by countries, table 4 presents banks average overall technical, pure technical and scale efficiency by country over the sample period 1999-2007 using both common and nation specific efficient frontier (NSF).

Libyan banks came in the first place in the common frontier computation when CRS or technical efficiency is considered and second when VRS was assumed. Possible explanation for these surprising results is that perhaps, as noted by Berger (2007) there might be there is a number of differences between countries, which affect the calculated banks efficiencies. It could be speculated that since regulations and the rules of the Libyan banking sector prohibits to any person to keep his salary and benefits out of the public banks, this could lead to some kind of compulsory deposit.

Table 4: Average Efficiency by Country for the Period 1999-2007 Common Efficient Frontier (Unless Specified Otherwise)

YEAR	TE (CRS scores)			P.T.E (VRS scores)			S.E		
	With Libya	Without Libya	NSF	With Libya	Without Libya	NSF	With Libya	Without Libya	NSF
Saudi Arabia	0.63	0.68	0.78	0.83	0.84	0.84	0.75	0.81	0.93
Kuwait	0.58	0.67	0.69	0.73	0.78	0.86	0.77	0.86	0.80
UAE	0.65	0.73	0.64	0.77	0.83	0.76	0.84	0.87	0.85
Qatar	0.67	0.68	0.77	0.76	0.77	0.84	0.88	0.89	0.93
Bahrain	0.53	0.48	0.28	0.68	0.63	0.57	0.76	0.81	0.53
Oman	0.61	0.67	0.84	0.67	0.74	0.90	0.91	0.92	0.94
Libya	0.74		0.70	0.81		0.74	0.90		0.95

Notes: TE=Technical efficiency, PTE=Pure technical efficiency;, CRS=Constant Return to Scale, VRS=Variable return to scale. SE=Scale efficiency. NSF: Nation-specific frontier

For these reasons the analysis was repeated without Libya, but still with a common frontier. It is reassuring to notice that there are no a big differences between the results with a common frontier with and without Libya. The correlation between the

efficiency scores between the two sets of results under CRS and VRS was 92% and 79% respectively. The coefficient correlation between the efficiency ranking derived from CRS and VRS analyses is .91. As mentioned before, the positive and strong correlation indicates that the rank of each bank derived from applying the two assumptions is similar. This implies that the choice of methodology has no significant impact on the estimated mean efficiency scores. Column 3, 6 and 9 of Table 4 reports the efficiency score by countries, using a national-specific frontier. Although comparability across nations would be meaningless, this measure could be interpreted as an indication of the dispersion of efficiency within a country. The results for Bahrain are quite noticeable for the very low score, indicating perhaps that few banks are operating at a very low level of efficiency.

5. Conclusion

This paper aimed at evaluating the level of efficiency of Libyan commercial Banks over the period 1999-2007 (as an indicator to the ability of Libyan banks to compete with other banks as Libya become a full member of the WTO) against the efficiency of banks operating in GCC countries. The efficiency level was calculated using the input-oriented Data Envelopment Analysis (DEA) technique, under both CRS and VRS assumptions.

Surprisingly, for a sample inclusive of both Libyan and GCCs banks, the results reveal that the mean efficiency score of the Libyan banking industry is not dissimilar to, if not higher than, the GCC country's mean. The analysis was repeated without Libya and the relative ranking of the GCC countries remained the same.

The full explanation for the results for Libya surely requires further empirical work, in terms of evaluating the impact of nation-specific characteristics in influencing the results. A further interesting finding is that efficiency scores have declined over the sample period on average, offering limited support to a positive impact of both membership of the WTO and successive reforms of the banking sector in the countries under examination. These results indicate the need for further research in this area.

6. References

- Abida, S .and Fayad, M. (2003) The expected effects of the WTO on Libyan financial sector, *Economic Research Journal*, Volume 2, pp. 86-118. (In Arabic) .
- Al-Faraj, Taqi N., Bu-Bshait, Khaled A. and Al-Muhammad, Wasel A. (2006) Evaluating the efficiency of Saudi commercial banks using Data Envelopment Analysis, *International Journal of Financial Services Management* ,Vol.1, No. 4, pp. 466-477.
- Alhasia, M. (1985) *Money, banking, and Economic Activity*, National Association of Science research. Libya. (In Arabic).
- Al-Muhrami, S. (2008) An examination of technical, pure technical and scale efficiencies in GCC banking. [*American J. of Finance and Accounting*](#), Vol. 1, pp. 152-166.
- Alwdan, A. (2005) Banking reforms and banking efficiency in Libyan commercial banks: A Non-parametric Approach. PhD thesis. Northumbria University.
- Arab Monetary Fund (AMF), (2005) Joint Arab Economic Report., Annual Report, Abu Dhabi. (In Arabic).
- Arab Monetary Fund (AMF), (2008) Joint Arab Economic Report., Annual Report, Abu Dhabi. (In Arabic).
- Avkiran, N.K., (1999a) An application reference for data envelopment analysis in branch banking: helping the novice researcher, *International Journal of Bank Marketing*, Vol.17, No.5, pp. 206–220.
- Avkiran, N.K. (1999b) The evidence on efficiency gains: the role of mergers and the benefits to the public, *Journal of Economics and Finance*, Vol.23, pp.991-1013.
- Avkiran, N. K.(2000) Rising productivity of Australian trading banks under deregulation1986-1995 , *Journal of Economics and Finance*,Vol.24, No.2, pp.122-140
- Avkiran, N.K. (2002), *Productivity Analysis in the Service Sector with Data Envelopment Analysis*. 2nd ed, Camira, Qld.
- Banker, R.D., Charnes, A.,and Cooper, W.W. (1984) Some models for estimating technical and Scale efficiencies in Data Envelopment Analysis, *Management Science*, Vol. 30. No.9, pp.1078-1092.
- Berger, A.N. (2007) International comparisons of banking efficiency, *Financial Markets, Institutions and Instruments*, Vol.16,pp. 119–144.
- Berger, A.N., Leusner, J.H., Mingo, J.J. (1997) The efficiency of bank branches, *Journal of Monetary Economics*, Vol. 40 ,No.3, pp.141-62.

- Casu, B. and Molyneux, P. (2003) A comparative study of efficiency in European banking, *Applied Economics*, Vol. 35, No. 17, pp. 1865-1876.
- Charnes, A, Cooper, W.W, Rhodes, E (1978), Measuring the Efficiency of Decision-making units, *European Journal of Operations Research*, Vol. 2, No. 6, pp. 429-44.
- Coelli, T.J. (1996) A guide to DEAP version 2.1: a data envelopment analysis (computer) program. Working Paper No. 96/08, CEPA (Centre for Efficiency and Productivity Analysis), Department of Econometrics, University of New England, Australia.
- Dyson R.G, Allen R, , Camanho A. S, Podinovski V .V, Sarrico C.S and Shale E.A. (2001) Pitfalls and protocols in DEA. *European Journal of Operational Research*, Vol. 132 ,pp. 3-17.
- Emrouznejad, A., Parker, B., and Tavares, G. (2008) Evaluation of research in efficiency and productivity: a thirty years survey of the scholarly literature in DEA, *Socio-Economic Planning Sciences*, Vol. 42, No. 3, pp. 151-157.
- Evanoff, D. D., and Israilevich, P. R. (1991) Productive efficiency in banking, Federal Reserve Bank of Chicago. *Economic Perspectives*, Vol. 15, No. 4, pp 11–32.
- Hufbauer, G. C., and Brunel, C. (2008) *Maghreb regional and global integration: A dream to be fulfilled*. Peterson Institute for International Economics. Washington.
- Mostafa, M. M. (2007a) Benchmarking top Arab banks' efficiency through efficient frontier analysis. *Industrial Management & Data Systems*, Vol. 107 ,No. 6, pp 802–823.
- Mostafa, M.M. (2007b) Modelling The efficiency of GCC banks: a data envelopment analysis approach, *International Journal of Productivity and Performance Management*, Vol. 56, No. 7, pp 623-643.
- Murinde, V. and Ryan, C. (2002) The implications of the General Agreement on Trade in Services (GATS) for the banking sector in the Gulf Region, in C. Milner and R. Read (ed.), *Trade Liberalisation, Competition & the WTO*, Cheltenham: Edward Elgar, pp. 92-117.
- Ramanathan, R., (2007) Performance of banks in countries of the Gulf Cooperation Council, *International Journal of Productivity and Performance Management*, Vol. 56, No. 2, pp. 137-154.
- Rabb and Lichty (2002) Identifying sub-areas that comprise a greater metropolitan area: The criterion of county relative efficiency. *Journal of Regional Science*, Vol. 42, pp. 579-594.

Smith, P. (1997) Model misspecification in data envelopment analysis. *Annals of Operations Research*, Vol .73, pp. 233–252.

Tarawneh, M. (2006) A comparison of financial performance in the banking sector: Some evidence from Omani commercial banks, *International Research Journal of Finance and Economics*, Vol. 3, pp. 101-112.

World Trade Organisation.(2010) Understanding the WTO: The Organization: Members and Observers [online] Available at:

http://www.wto.org/english/thewto_e/whatis_e/tif_e/org6_e.htm

(Accessed on 10th December, 2010).

Yue, P. (1992) Data Envelopment Analysis and commercial bank performance: a primer with applications to Missouri banks, *Federal Reserve Bank of St Louis Review*, Vol.74, pp31-45.

An ethnographic study of the culture in a Diagnostic Imaging Department (DID) – some personal reflections

Ruth M Strudwick, Stuart Mackay and Stephen Hicks, *University of Suffolk*

Abstract

This paper is a discourse arising from my doctoral thesis for my Professional Doctorate (DProf). The thesis is an ethnographic study of the culture in a DID. This paper is focussed on personal reflections from the research process. Areas discussed include conducting research in my own profession of Diagnostic Radiography and the positive and challenging aspects of looking into my own professional culture in depth. The paper concludes with some of the lessons learnt during the process.

Keywords:

Ethnography; Qualitative research; Diagnostic Radiography; Diagnostic Imaging Department; Culture; Observations; Interviews

1. Introduction

Rather than writing another paper articulating my findings I thought it would be useful to discuss the research process and to share my experiences as a researcher. I am not in the final year of my DProf and I am writing up my thesis.

My study was carried out over a 7 month period in a DID in the east of England. The first 4 months of the study were spent carrying out participant observation within the DID. It was difficult at first to adjust to being in the department but not working there. As a practitioner I had a feeling of guilt about not having a clinical role and being able to assist the diagnostic radiographers (DRs). This was particularly true when the department was busy and all I wanted to do was to take the next X-ray request form and image the patient. Rudge (1995) also highlights this tension and talks about the ethics of assisting in the practice area when your role there is to be a researcher and to observe. Johnson (1995) says that health care professionals as researchers will feel torn between the needs of the patients and the researcher role.

After the observation I conducted interviews with 10 key informants to explore further some of the issues uncovered by the observation. These interviews were semi-structured in nature; each interview was recorded and transcribed verbatim.

I had originally planned to study the documents used within the DID, but I abandoned this as it became apparent early into the study that DRs rarely use these documents in their work. In fact, most of the information was conveyed verbally. DRs were more likely to ask their colleague than look it up or find the relevant policy or protocol. This finding is shared by Hunter et al. (2008) in their ethnography of a neonatal ward.

RELATIONSHIPS WITH PATIENTS	RELATIONSHIPS WITH COLLEAGUES
TASK FOCUSED INTERACTIONS TIME PRESSURES AND WAITING TIMES PATIENT ASSESSMENT AVOIDING CONFRONTATION CATEGORISING PATIENTS ETHICAL DILEMMAS INVOLVEMENT WITH PATIENTS	TEAM WORKING AND COMMUNICATION BETWEEN DRS INTERPROFESSIONAL RELATIONSHIPS DR – RADIOLOGIST RELATIONSHIPS DISCUSSION AND STORY TELLING TRANSFER OF INFORMATION IN THE DID ROLE MODELLING USE OF DARK HUMOUR
STRUCTURE AND ENVIRONMENT	CHARACTERISING THE ROLE OF THE DR
STRUCTURE, ORGANISATION, ROUTINE – THE WAY THINGS ARE DONE WORKFLOW, PRESSURE FOR ROOMS AND PRIORITISATION BLAME CULTURE BEHAVIOUR IN DIFFERENT AREAS DEPERSONALISING PATIENTS INTERACTION WITH COMPUTERS AND EQUIPMENT SEEING THE BIGGER PICTURE	VIEWS ABOUT RESEARCH, CPD AND EVIDENCE-BASED PRACTICE EXTENDED ROLE AND BARRIERS DEALING WITH RADIATION USE OF KNOWLEDGE AND TEACHING VISIBLE PRODUCT

Figure 1: Results – overarching themes

2. Results of the study

The data from the observations and interviews was analysed using a thematic analysis. The data was coded, with no restrictions in the number of codes used. Hammersley and Atkinson (1991) advocate this approach as it does not place any limits on the data. Hammersley and Atkinson (1991) suggest a ‘funnel shaped’ structure within

data analysis, so that analysis becomes more focussed over time with the large number of small codes being grouped together to form a smaller number of overarching themes as the analysis progresses.

There were 26 codes in all. After the data was coded it was grouped together under 4 overarching themes. These are shown in figure 1.

3. Studying 'in my own nest'.

Many authors have written about this (Bonner and Tolhurst, 2002; Cudmore and Sondermeyer, 2007; Roberts, 2007). There can be a real tension and difficulty in determining your particular role. The benefits of studying in your own area of practice are that you already know the profession well; you know what the job involves. You also know the cast of characters involved and you understand the terminology being used.

However, it may be difficult to distance yourself and to take on the role of researcher instead of practitioner in your own practice area. It may be difficult to develop the 'outsider's' perspective and to see the environment with a sense of strangeness (Roberts, 2007; Allott and Robb, 1998).

Because of my position as an educator at the university I was fortunate to be on first name terms with all of the radiology managers in the region that provided clinical placements for the diagnostic radiography students. I was able to present my research idea to the regional managers group and one of the managers offered to host my research and was very interested in my study. This made it relatively easy for me to gain access to the DID. Allott and Robb (1998) cite this as a distinct advantage of doing research in your own area of practice. I consider myself very fortunate.

However, because of the way in which I gained access to the research field I was aware that the participants may feel coerced into taking part. I made every effort to ensure that the participants made an informed decision about taking part and did not feel obliged to do so because the manager had given permission for the research.

Roberts (2007) discusses coercion in her paper about carrying out research on her own students. She was aware of the pressure to consent to be involved in eth study for students as she was their lecturer. However, she points out that from her experience the students were not easy to coerce into divulging information that they wanted to keep private. I agree with this notion, and I believe that the staff in the DID had the opportunity not to participate in my study and they also had many opportunities to discuss subjects that they did not want me to hear about or be aware of outside of my earshot.

4. Personal reflections

Throughout my work I have chosen to reflect using my 3 roles; researcher, practitioner and educator.

5. As a researcher

One of the highlights of the DProf was actually conducting the research and collecting the data. At times I had to 'think on my feet' and problem solve. This is an area I thrive on in both my personal and professional life and I relish the challenge. The inductive nature of my research maintained my interest in the topic and I feel passionate about my research and about my findings. There was a real sense of achievement when I completed the data collection, for me this was a real milestone in the research process.

I do not think that I was aware at the start just how difficult it would be to write my methodology section and to justify the reasons for the choices that I made. I was a little naive in thinking that any reader should be able to understand what I had done and why I had done it. There were many issues that I had to explore which I had not really considered such as the ethical issues. If I were to start again I would take longer to prepare before starting the observation as I felt at times that I was 'fire fighting' when an issue came along, as I had not thought about how best to deal with it beforehand. I would also pilot my interviews with a colleague as I had no real idea of how long they would last and I think that my interview technique improved as I went along. However, as a novice researcher these problems are bound to occur and I learnt from them.

Before the commencement of the study I had to ensure that all of the staff were informed and were able to give consent. I spoke to all of the staff at their staff meeting and provided them with a participant information sheet and my contact details. After they had had time to read about the study they were asked to complete the consent form. Staff members were able to opt out of the study at any time. Participant consent forms were collected by one of the superintendent DRs.

The Local Research Ethics Committee (LREC) asked me to ensure that patients gave their consent for me to observe them. This was achieved by placing a notice in the patient waiting room in the DID and asking each patient being observed for their permission, this was practiced by other similar studies such as May-Chahal et al. (2004). It is difficult to obtain consent from everyone and Johnson (2004) says that “ethnographers in complex social situations are rarely able to gain consent from everyone they meet” (p253). This did not achieve informed consent for the patients but no patient details formed part of the study as my primary focus was on observing the DRs and their practice. The LREC were satisfied with this level of consent for patients as I was abiding by my professional code of conduct with regards to patient information.

Before the commencement of the study I had to decide how I would deal with the observation of mal-practice. It was decided in discussion with the manager of the DID that I would intervene if necessary and that I would report any instances to the manager of the DID. This was difficult for me as I did not feel that this was my role as a researcher to ‘police’ the department. Dixon-Woods (2003) says that “ethical issues about when and how to intervene are not uncommon” (p326), and other writers speak about the dilemma of observing bad practice and if intervention is necessary (Hobbs and May, 1993; McGarry, 2007).

Johnson (1997 and 2004) discusses why intervention is a difficult concept for researchers in the clinical environment. He calls the lack of intervention by a researcher the ‘wildebeest perspective’ (Johnson, 1997), referring to nature documentaries where the person filming does not intervene when the predator stalks and eats the vulnerable newborn and ageing wildebeests, it is argued that intervention would disturb or intervene with nature. Johnson (1997) argues that in some cases researchers should perhaps have intervened, for example to relieve pain. He goes on

to state that it is useful to consider where interventions or their avoidance can be planned for or predicted in research, but this does not reflect the turmoil of the real and messy world of clinical research. When considering when I might have to intervene I realised that it was not as simple as saying I would intervene when I thought that the patient or my colleagues was in danger or at risk. This was fine in terms of radiation dose, but there could be other occasions where there could be a small risk or maybe where I felt that the care of the patient was not optimal. I needed to decide where I would draw the line. As a DR I needed to abide by my professional code of conduct and this provided some guidance. Johnson (2004) calls this an 'intervention dilemma' and suggests the development of a personal 'bottom line' of care below which the researcher feels they must intervene. For me this was if I felt that anyone could be physically harmed unnecessarily as a result of an interaction. It is important to report practice that is less than satisfactory in research, because although this may be controversial, without reporting such incidents future practice cannot improve and the profession can move forward.

Thankfully I did not have to intervene at any time during my research, although I did observe some less than satisfactory practice with regard to communication with patients. As an educator I found it difficult to stand by and observe these interactions, I wanted to take the DR to one side and help them to reflect on and learn from what had happened, but this was not my role as a researcher.

During the study there needed to be a mechanism for staff to withdraw from the study. It was agreed that should a staff member wish to withdraw they could either inform me as the researcher or they could inform one of the superintendent DRs in the DID who would tell me. If a staff member decided to withdraw from the study all data relating to them would also be removed from the study.

From the 45 staff members working in the main DID at the time of the study, only 2 did not consent to being observed. Agreement and consent to participate was therefore strong with 43 out of 45 staff consenting. During the study none of the members of staff withdrew from the study. So it was relatively easy to manage to avoid observation of the 2 staff that did not consent.

At the end of the data collection, when the observation and interviews were completed I was sad to leave the DID. I felt that I become part of the team, and had made some

lasting friendships with some of the DRs. Chesney (2001) reflects on this issue at the end of her study, she says that she found it hard to leave a group that she had become a part of. Coffey (1999) takes this further saying that researchers always have an emotional involvement with their first set of participants, calling them the 'first love'. She says that "ethnographers rarely leave fieldwork totally unaffected by their research experience" (p7), and that this is rarely talked about in the research texts, it is a "silent space" (p8) where experiences are not spoken about. I felt that I had left a team that I had become a part of and left a group of friends.

However, I was also optimistic that my research would have a positive effect on the DID. I had asked a lot of questions, and challenged the DRs to consider their practice and the reasons behind the decisions they made. Simmons (2007) talks about affecting change through research, and proposes that the researcher can challenge the reasons for behaviour through questioning, resulting in changes in practice.

6. As a practitioner

Carrying out research in my own profession of diagnostic radiography has been really interesting. I have been able to look at my own profession in depth.

During the observation I wore a DR's uniform. My decision to wear uniform helped me to integrate into the department. However, this prompted thoughts about how I felt to be wearing uniform and yet not being involved in the care and imaging of patients. As professionals the wearing of uniform is a powerful statement and it helps us to take on our professional role and persona. I had not realised just how powerful the wearing of a uniform can be to a person and how it was part of my own professional identity. For me, when I wear the uniform I am a practitioner and when I visit the DID without my uniform I am a visitor or an educator. So wearing the uniform but taking on another role, as a researcher was a real challenge to me and to my identity. I struggled with the fact that I was dressed as a radiographer but was not 'being' a radiographer. This is a concept referred to by Cudmore and Sondermeyer (2007) as being there but not being there. It has been argued that without true immersion in the culture the researcher cannot provide an authentic account (Allen, 2004). Therefore I spent the whole of each day of the observation with staff including eating lunch and taking tea breaks in the staff room. I felt that this helped me to become integrated into the team and recognised as a part of the staff group. I was

conscious that I did not want to appear aloof and someone who did not wish to engage with the DRs. Chesney (2001) describes the veils of research and how the actual researcher (the person) can be hidden. She advocates being open, honest and up front, not hiding the real you. Chesney maintains that in order to accept the credibility of the research the reader must be able to scrutinise the integrity of the researcher.

However, as a practitioner I found it difficult to come to terms with some of the less flattering results that came to light about my profession. For me, this was quite difficult to come to terms with. I found it difficult to observe some of the negativity that is evident within the profession. It was sad to see that some DRs do not show interest in CPD, evidence-based practice and research. There seems to be apathy towards moving the profession forward or wanting to see progression within radiography. I was also disappointed to observe the way in which DRs communicate with colleagues from other professions. There appeared to be a lack of understanding and awareness of one another's roles and a lack of willingness to find out what other professions do. DRs need to ensure that other professionals understand their role and that they understand the role of other professionals in order to promote Interprofessional team working.

I also observed some poor communication between DRs and patients which was difficult to deal with. I wanted to intervene, but as discussed earlier in the methodology section, this was not the reason for my presence, so I did not intervene.

I do, however feel that it is important to uncover these issues. I hope that in the dissemination of my findings I can make a positive contribution to the future of the radiography profession and increase awareness amongst DRs. The findings from my research will assist DRs, prospective DRs and other professionals in understanding the workplace culture within a DID and amongst DRs.

7. As an educator

As an educator I was particularly interested in the way in which students learn from others through role modelling. It was evident from this study that a lot of the behaviour I saw was learnt from others and that students learnt to 'fit in'. I was interested to see how DRs taught one another informally through sharing and discussing their practice with one another.

This made me think that it does not matter what I teach my students at university if this is not being reinforced in practice. A good example of this from my own experience is interprofessional learning (IPL). At the university IPL is part of all pre-registration health and social care programmes and it is positively promoted. Students are encouraged to learn with, from and about one another. However, from my study it is clear that interprofessional working is not always positively promoted in practice. DRs and other professionals chose to criticise one another and complain that other professionals do not understand their role. So student DRs do not see the importance of IPL in practice.

There were several occasions during the research that I wanted to intervene and teach the DRs or challenge them to reflect on something that had happened. This made me think that as educators we do need to get out into practice and see what the educational needs are of our practitioner colleagues, so that we can assist them in their own CPD.

8. Conclusion

On reflection there are 3 main lessons that I have learnt from the DProf.

1. Preparation:

Thorough preparation for research is needed so that you can deal with any dilemmas that may be encountered. It is important to think through and consider the possible issues that may arise and how you will deal with them, for example when you might have to intervene. It is also worth preparing for your attachment to the field and your participants and thinking about what it will be like to leave the field. I found this particularly challenging. Finally, you need to be prepared for the findings of your study as they could be controversial.

2. Personal development:

For me it has been as much about the process as the product. It has been great to see the finished product, a dissertation that I have written, but for me the journey to that final point has been just as important. I have learnt a lot about myself and the way in which I work. I was asked to write some snippets for my course leader's book about achieving a DProf (Lee, 2009), and one of the quotes that I cited to sum up how

I was feeling was from Chesney (2000) in her reflective piece about understanding her place in the research where she says “clearing the view to myself has served to help me understand others” (p68). This for me summarises what the DProf has been for me, an exploration of myself which has lead me on to an exploration of my profession. I was able to look myself, my colleagues and my profession from a different perspective and start to explore some of the reasons behind their culture and behaviour. I have been able to explore tacit knowledge as well as overt knowledge and it has been interesting to look at why DRs exhibit certain behaviours and the reasons behind practice.

The process for me has also meant a change in the way that I view the world around me. Over the past 5 years I have become a more reflective and analytical person. I am much more measured in my responses to issues, questions and discussion. I think I am more able to see others’ point of view. I have developed my critical thinking skills, and feel better equipped to read and listen to the work of others and question their approach. I think this comes from the observation and interpretation that has been part of the research process, and also from reading other peoples’ work and writing my own work.

Because of the DProf I know that I spend a lot more time thinking about the words I will use when writing and speaking, and I also tend to analyse the words that others use when communicating with me. I am much more critical and spend more time trying to convey my exact meaning. I guess that this stems from writing a dissertation where every word counts and is significant, and I feel under pressure to get it right.

3. Publications:

One of the highlights for me was to have some of my DProf work published (Strudwick, 2008; Strudwick, 2009; Strudwick, 2010) and having the opportunity to present my research at conferences. I have enjoyed the experience of sharing my work with others and feeling that I have something to contribute to the debate.

9. References.

- Allen D (2004) Ethnomethodological insights into insider-outsider relationships in nursing ethnographies of healthcare settings. Nursing Inquiry 2004, 11(1), p14-24.
- Allott M and Robb M (Eds)(1998) Understanding Health and Social Care – An Introductory Reader. Sage, London.
- Bonner A and Tolhurst G (2002) Insider-outsider perspectives of participant observation. Nurse Researcher 9, 4, p7-19.
- Researcher Vol 7, No. 3, Spring 2000, p58-69.
- Chesney M (2001) Dilemma of Self in the Method. Qualitative Health Research. 2001: 11:127-135.
- Coffey A (1999) The Ethnographic Self. Sage, London
- Cudmore H, and Sondermeyer J (2007) Through the looking glass: being a critical ethnographer in a familiar nursing context. Nurse Researcher 2007, 14:3, pp25-35.
- Dixon-Woods M (2003) What can ethnography do for quality and safety in health care? Quality and Safety in Health Care, Oct.2003, 12, 15, p326-327.
- Hammersley M and Atkinson P (1991) Ethnographic Principles in Practice. Routledge, London.
- Hobbs D & May T (Eds.) (1993) Interpreting the field – Accounts of ethnography. Oxford University Press, Oxford.
- Hunter C L, Spence K, McKenna K and Iedema R (2008) Learning how we learn: an ethnographic study in a neonatal intensive care unit. Journal of Advanced Nursing, 2008, p657-664.
- Johnson M (1995) Coping with data in an ethnographic study. Nurse Researcher, Vol. 3, No. 2, December 1995, p22-33.
- Johnson M (1997) Observations on the neglected concept of intervention in nursing research. Journal of Advanced Nursing, 1997, 25 p23-29.
- Johnson M (2004) Real world ethics and nursing research. Nursing Times Research. 2004: 9: 251-261.
- Lee N J (2009) Achieving your Professional Doctorate – A handbook. Open University Press, Maidenhead.

- May-Chahal C, Hicks S and Tomlinson J (2004) The relationship between child death and child maltreatment – A Research study on the attribution of cause of death in hospital settings. NSPCC, London
- McGarry J (2007) Nursing relationships in ethnographic research: what of rapport. Nurse Researcher 2007, 14, 3, p7-14.
- Roberts D (2007) Ethnography and staying in your own nest. Nurse Researcher 2007, 14:3, pp15-24.
- Rudge T (1995) Response: Insider ethnography: researching nursing from within. Nursing Inquiry. 1995; 2; 58.
- Simmons M (2007) Insider ethnography: tinker, tailor, researcher or spy? Nurse Researcher 2007, 14, 4, p7-17.
- Strudwick R M (2008) Why Ethnography is a suitable methodology to study the culture in a Diagnostic Imaging Department (DID). Proceedings of the Salford Postgraduate Annual Research Conference, 8th-9th May 2008, University of Salford, Research and Graduate College, p230-241.
- Strudwick R (2009) Looking from the inside out. Synergy, December 2009, p20-23.
- Strudwick R M (2010) An ethnographic study of the culture in a Diagnostic Imaging department (DID) – some initial findings. Proceedings of the Salford Postgraduate Annual Research Conference, 2009. University of Salford, Research and Graduate College, p364-373

The antecedents for knowledge sharing behaviour among Malaysian undergraduate Students

Nor Intan Saniah Sulaiman, *Salford Business School, University of Salford*

Abstract

This research was study how knowledge sharing behaviour is implemented among Malaysian undergraduate communities. The research question is: What makes knowledge sharing behaviour successful among two Malaysian undergraduate communities in United Kingdom and Malaysia? The aim of this research is to identify the antecedents for effective knowledge sharing behaviour among Malaysian undergraduate students. On that basis, this research had investigated on how Malaysian undergraduates are using Web 2 .0 applications for knowledge sharing behaviour. For a pilot study, document archival through a search engine has been conducted before the main study. The purpose was to prepare the researcher in exploring the background of the community. The pilot study also had identified challenges and difficulties in handling the community members if knowledge sharing had not been implemented. An interview and email question approach was implemented to identify the types and medium of knowledge shared among Malaysian undergraduates. The target interviewees were from student leaders in a student community representing Malaysian undergraduate students. The findings from the pilot study were be used in secondary data collection for the following stages in this research. The online questionnaire survey will be implemented in the three different cities for validation purposes. A model of antecedents in knowledge sharing methods among Malaysian undergraduate's students is the main contribution of this research.

Keywords:

Knowledge sharing behaviour, Malaysian undergraduate students, Web 2.0, antecedents, knowledge management

1. Aims and Objectives

This research aim is to identify the antecedents for effective knowledge sharing behaviour among Malaysian undergraduate students. The main five objectives are:

- 1-Identifying the types of knowledge shared among Malaysian undergraduates who are members registered within the two Malaysian communities
- 2-Exploring the process of knowledge sharing among Malaysian students by using content analysis of Malaysian student weblogs
- 3-Comparing similarities and differences of knowledge sharing behaviour among Malaysian students in two different cities; Manchester and Kuala Lumpur
- 4-Creating a way of evaluating the effectiveness of knowledge sharing behaviour
- 5-Developing a model of antecedents of knowledge sharing behaviour among Malaysian undergraduates' students

1.1. Research Rationale and Scope

Currently many knowledge management studies have been done in diverse sectors in Malaysia. For example, in the public services (Salleh and Ahmad, 2005; Ikhsan and Rowland, 2004a; Ikhsan and Rowland, 2004b; in small and medium enterprises (Wong (in Sharimllah Devi et al., 2007), in information technology (IT) Multimedia Super Corridor (MSC) organizations (Chong a; Chong b; Chong and Lin; Chong et al, (in Sharimllah Devi et al., 2007)), in telecommunication (Chong et al.(in Sharimllah Devi et al., 2007)), in oil and gas (Abdul Aziz and Lee 2007) and also in finance and banking (Ali and Ahmad,2006). Studies on knowledge management in the education sector existing but are limited. However, there has been little discussion about KM in education. Currently, only two studies have been found. The first research focuses on KS implementation among academic staff in Klang Valley (Jain et al., 2007). The second research study about organisational culture and KM processes from the perspective of an institution of higher learning (Sharimllah Devi et al., 2007). However, far too little attention has been paid to KS implementation among university students. Currently, this work has been applied to Singapore and only focuses on knowledge sharing patterns in student learning styles (Yuen and Majid, 2007).

This study will be restricted to Malaysian undergraduates' students who have good communication skills as well as basic IT skills. Eppler (2007) has suggested that knowledge communication has become an interactively assigning insight, either verbal or non-verbal. Furthermore, communication skills have become one of the most important elements needed. Currently, communication tools which are affected by technology have also become extremely important. That is the reason makes people become a competitive society due to rapid changes in trends now (Burke, 2007).

1.2 Contribution to the Body of Knowledge

This research is based on findings from previous research studies (Jain et al., 2007; Yuen and Majid, 2007; Ramirez, 2007; Al-Alawi et al., 2007 and Zheng, 2005) on the relationship between knowledge management, knowledge sharing and technology Web 2.0. The main contribution from this research is the integrated adapted theories and construction of a model on antecedents of knowledge sharing behaviour among Malaysian undergraduates' students. No research has been found with this model based on current investigation. At the end of this study, five new findings hopefully to achieve and can assist Malaysian undergraduates' students to prepare themselves being as good person. The good person here means that knowledge-sharing life-style during their student life in campus. The five new findings were:

1. The types of knowledge shared among Malaysian undergraduates.
2. Mediums of how knowledge was shared among Malaysian students.
3. Differences of knowledge sharing behaviour among Malaysian students in two different cities; Manchester and Kuala Lumpur
4. Effectiveness knowledge sharing behaviour using the appropriate theory.
5. Model for knowledge sharing behaviour for Malaysian undergraduates' students.

2. Conceptual Framework

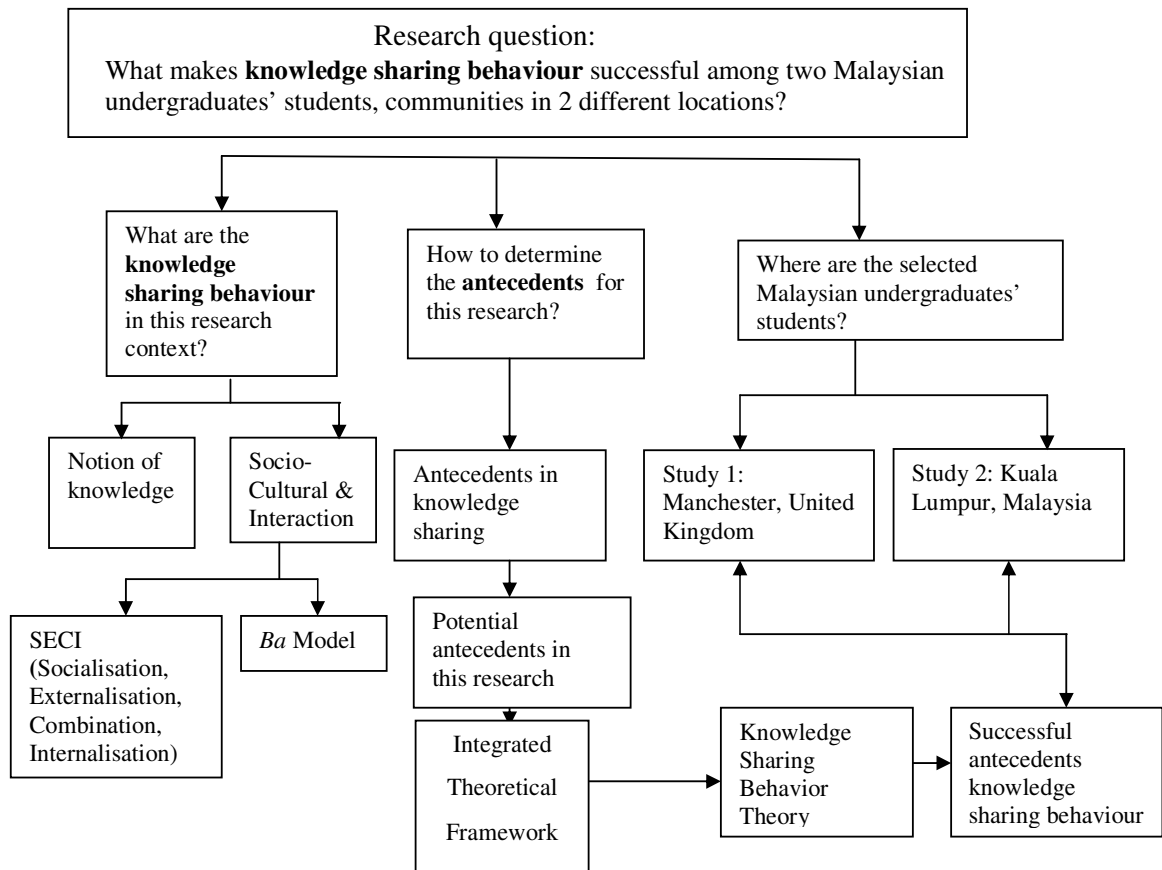

Figure 1: Conceptual Framework for this research

2.1 Existing Research in Knowledge Sharing Behaviour (KSB)

Google, Google scholar, an electronic database at the university, and the Yahoo! search engine were used to search for KS papers. This searching activity can be achieved by social networking or social interaction with the other researchers when attending the conferences. Besides ‘KS’, other significant terms such as knowledge transfer (KT), “knowledge diffusion” and “leveraging of knowledge”, were used in the keyword search. For example, the KT term emphasizes the movement of knowledge within an organization and the dependability on the human or individual characteristics involved with regards to the definition of KS (Szulanski, 1996).

The ‘Journal of KM’ and ‘KM Research and Practice’ are journals which represent important published researches in the field of KM and are used as the main journals for KS (Shaari, 2009). Besides that, more articles can be found through the reviews of journals’ citations. KS is the act of making knowledge available to others within an organization (Ipe, 2003). In the KS researches, which have almost all been done in the past ten years, there are huge areas involved and they use the KS concept within the KM approach. Based on Table 1, the diversity of areas that have been applied to the concept of KS has been classified. The elaboration on the reliable areas with the research context is also has discussed.

Table 1: Classification on relevance to KSB study within this research context

Relevance to this research context		
Areas	Contributions to this research	Authors / Research gaps with this research context
1-Communities	Community issue as focus group	Kubo et al. (2001) Scott and Laws (2006) Plessis (2008) Kamau and Harorimana (2008) Hsu et al. (2007) = no studies from these authors are

		focusing on student communities
2-Human Behaviour	The main theme for this research = knowledge sharing behaviour (KSB)	<p>Cabrera et al. (2006)</p> <p>Handzic and Lagumdzija (2006)</p> <p>Tedmori et al. (2007)</p> <p>Christensen (2007)</p> <p>Shah Alam et al. (2009)</p> <p>= no studies from these authors are focusing on knowledge sharing behaviour (KSB) involving students</p>
3-Staff or student development	As the aim of this research (student development)	<p>Georgiodou et al. (2006)</p> <p>Jain et al. (2007)</p> <p>Yuen and Majid (2007)</p> <p>Sulaiman (2009)</p> <p>= no studies from these authors are focusing on knowledge sharing behaviour (KSB) involving student development</p>
4-IT	As one of the identified Antecedents for KSB	<p>Song (2002)</p> <p>Khandelwal and Gottschalk (2003)</p> <p>Kim and Lee (2006)</p> <p>Quientero (2007)</p> <p>Mustafa and Abubakar (2009)</p> <p>= no studies from these authors are focusing on success factors involving IT within knowledge sharing behaviour (KSB) issues</p>
5-Critical success factors/Antecedents	As the aim in this research	<p>Tseng and Chen (2006)</p> <p>Handzic and Lagumdzija (2006)</p> <p>Lok et al. (2007)</p> <p>Al- Alawi et al. (2007)</p> <p>Kharabsheh (2007)</p> <p>Scarso et al. (2007)</p>

		<p>Majewski and Usoro (2008)</p> <p>= no studies from these authors are focusing on antecedents within knowledge sharing behaviour (KSB) involving student development aims</p>
6-Higher education issues	As the type of focus group	<p>Jain et al. (2007)</p> <p>Yuen and Majid (2007)</p> <p>Buckley and Giannakopoulos (2009)</p> <p>= no studies from these authors are involving within two different location studies but have same characteristics in terms of the nationality</p>
7-Web 2.0 (Wikis, weblogs, social networks)	As one of the identified Antecedents	<p>Ramirez (2007)</p> <p>Miao and Yli-Laoma (2007)</p> <p>Smith (2008)</p> <p>Garcia-Perez and Ayres (2009)</p> <p>Neto and Correria (2009)</p> <p>Ignacio et al. (2009)</p> <p>= no studies from these authors are focusing on success factors involving Web 2.0 within knowledge sharing behaviour (KSB) issues involving student development aims.</p>

2.2 Malaysian Undergraduate Students (MUS)

Malaysia is one of the developing countries in South East Asia. Nowadays Malaysia is heading to become an industrialised country by the year 2020. The aim is that by the year 2020, Malaysia will be a “developed country in our own mould” (Mohamad, 1997). However, even though Malaysia has rich natural resources, it still is not promising enough to bring Malaysia towards achieving the status of a developed nation. The most important resource to be developed is its people (Shaari, 2009).

“Nothing is more important than the development of human resources. Our people are our ultimate resource.” (Mohamad, 1997)

That is the main reason why Malaysia is concerning on the tertiary education for their people. Undergraduate students are among individual who are in tertiary education level. In this country, Malaysia has provided an excellent place for their people to gain further tertiary education. The higher education ministry monitors the higher education system. Meanwhile the public universities and private universities play an important role in providing excellent facilities for the undergraduate students in Malaysia.

Higher Education also plays an important role for the nation and is continuously expanding its role for improvement from time to time in order to fulfil the requirements (Ahmad, 2004). Moreover, it plays several important roles in society and the economy. Fulton and Ellwood (1989) state that there is little serious consideration of what the role of higher education is. Their book highlighted five main purposes for higher education: skill development, selection, socialisation, scholarship and service. Others have elaborated on these roles. For example, Ruth (1998) amplifies the ‘scholarship’ role noting HE’s special contribution in creating a place for discovery, synthesis, reflection, and evaluation of knowledge. In addition, King (1995) identifies creation of new knowledge or knowledge value-added, through discovery, and notes that research and development are important to promote education excellence.

Table 2: Overview of Concepts in Relation to Development of Conceptual Framework

Concepts reviewed	Implications to this research
Knowledge sharing behaviour	Knowledge sharing behaviour is an act that is related to motivational factors because it is not spontaneous but rather needs to be nurtured or facilitated. Peoples' willingness to share is related to their self-efficacy and vice versa. There must be some form of organisational strategy to boost peoples' self-efficacy to share knowledge sharing behaviour.
Antecedents	From the literature review, it is revealed that the soft and hard factors are contributed to the antecedent's knowledge sharing specifically.
Malaysian undergraduates' students.	This variable is an important issue for this research. This is because it is the focus of the study. The surveys are based on the MUS, and the findings are from the Malaysian undergraduates' individual from the selected community.

3. Research Methodology

3.1 Paradigm choice

This research has adapted interpretive as the research paradigm because it involves human interests as the main drivers and the gathering of rich data from inductive ideas. The generalisation of the research will be done through theoretical abstraction (Easterby-Smith et al., 2008).

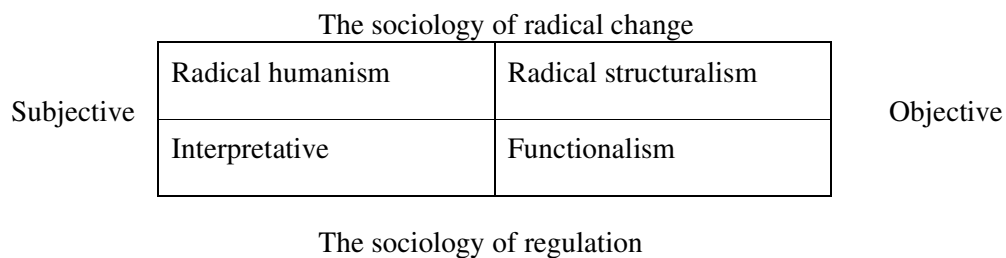

Figure 2: Identified paradigm for the analysis of social theory (Burrell and Morgan, 1979)

For this research, the nature of the research question is more on how humans behave in their life, and specifically, how the subjects practice their knowledge sharing behaviour in their student lives. The research context is more on understanding knowledge sharing behaviour using the technology Web 2.0. This means that this research should carry out participant observation. Furthermore this research is involved with humans and the interpretative is more suitable than the other paradigms.

3.2 Research Method

This research is based on the qualitative study approach (Creswell, 1998). The research is carried out through a weblogs survey which is focused on obtaining the same kinds of data from large groups of people or events in a standardised and systematic way (Oates, 2006). The survey method is chosen since it is the most suitable for IS research, a discipline which involves a community (Benbasat et al., in Myers, 1997). Furthermore, it can be used to look at patterns in the data findings before a generalisation is made to represent the population through the sampling.

3.3 Research Techniques

This research uses a variety of qualitative techniques. Qualitative research techniques include interviews, participant observation, and surveys on archival documents through secondary data which is in the form of weblogs. In qualitative research, the problem is unstructured and that is the reason why the qualitative technique is more efficient (Rasli, 2005). For the mode of analysis of this research, content analysis is applied through the Hermeneutics Theory. Hermeneutics Theory is based on interpretive philosophy and is used for interpreting meaning of text-analogue (Myers, 1997).

3.4 Main data collection and Ethics Issue

The main data collection for this research was done between June 2009 and October 2009. The main data collection started after the interim assessment examination. The researcher tries to use a non-sampling approach for this qualitative survey. The most suitable non-sampling for this research is snowball sampling. The ethics from the researcher's university has been applied to this research since April 2009 and the researcher got approval in November 2009. This is to ensure that the selected bloggers from each study noticed their indirect participation in this study. The consent form

was distributed to the bloggers through electronic mail after the data collection was done. This type of consequential view was applied to ensure the validity of the content of the bloggers (Sebreperez, 2009). The researcher selected fifteen bloggers from each study and they were from various levels, some of them juniors, some of them seniors, and some of them in the middle year of their studies. In addition, some of them have graduated and have had their own career, but they still have a relationship with the members in the community. However these various bloggers happened indirectly since the researcher found and selected the weblogs using snowball sampling. The researcher read all the entries of each weblog and just selected ones within one year of entries. If the entries have existed for less than a year, the researcher will ensure the entries from the bloggers must contain at least fifteen to twenty entries.

4. Data analysis and Main findings

The researcher has followed several steps in developing Figure 3. First, in this research identified the factors that were mentioned in the two previous studies. After that, the researcher has named them as common factors across the studies. From that, they have some similarities and differences. For example, in second perspective of Figure 3, they have been slightly different in the success factors based on Theory of Planned Behaviour compare to Social Cognitive Theory. In Study 1, the success factors are Subjective Norm and Behaviour itself. Meanwhile in Study 2, the identified success factors start with Behaviour and Attitude towards act or behaviour. For perspectives community and technology Web 2.0, they have similarities factors.

Finally, these identified success factors also validated through the validation online questionnaire which has been discussed in details in validation stages with online questionnaire to community members. All of these success factors have identified through the analysis stages in analysis chapters which are not discussed in this paper. The identification has manually analyses using content analysis approach which the researcher has look the highest sub elements. This sub-element comes from the integrated elements of knowledge sharing behaviour theory to sub factor to achieve the aim for this research.

Success Factors Perspectives in Community - Social Value

Knowledge Sharing Behaviour (KSB) Theory:

FAIRNESS AND ENJOYMENT

Subjective Norm= Human beliefs = Cognitive Competencies

Behaviour = Person's behaviour = Performance [Generalized Norm

Success Factors Perspectives in Personal – Content Value

Knowledge Sharing Behaviour (KSB) Theory:

IDENTIFICATION AND SHARING AWARENESS

Attitude towards act or behaviour

Subjective Norm= Human belief = Cognitive Competencies

**Success Factors Perspectives in Technology Web 2.0 –
Technology Value**

Knowledge Sharing Behaviour (KSB) Theory:

OPENNESS AND USEFULNESS (RELEVANCY)

Equilibrium to a balance in the social exchanges through:

Figure 3: Identified success factors across Study 1 and Study 2

From all the proven statements, this model is appropriate for this research. From Figure 7, the three levels in antecedents in knowledge sharing behaviour are uncovered as system quality, information quality and service quality. In this research context, the system quality turning to community itself, meanwhile the information quality is look up to personal itself and then the service quality is look at to web 2.0 tool or information communication and technology facilities itself.

All the sub factors for every level of antecedents have been explained in content of community, personal and technology Web 2.0. These sub factors are connected to medium of knowledge sharing, benefits from it and user satisfaction. From the origin

of the model, medium indicate of intention to use and benefits of it signify of use. Meanwhile the user satisfaction on this knowledge sharing behaviour has measured from validation questionnaire and from that the level of success factors can be identified, community, 75% , personal, 60% and web 2.0/ICT, 50% .

From medium of knowledge sharing, the benefits and user satisfaction contribute to net benefits, which all the finding stages are listed in this factor- successful knowledge sharing. It shows the types of knowledge, idea mapping, and validation questionnaire are the findings stages by stages in this research. Figure 4 until Figure 6 exhibit the detailed models based on the adapted integration models for CSF of KSB (Figure 7).

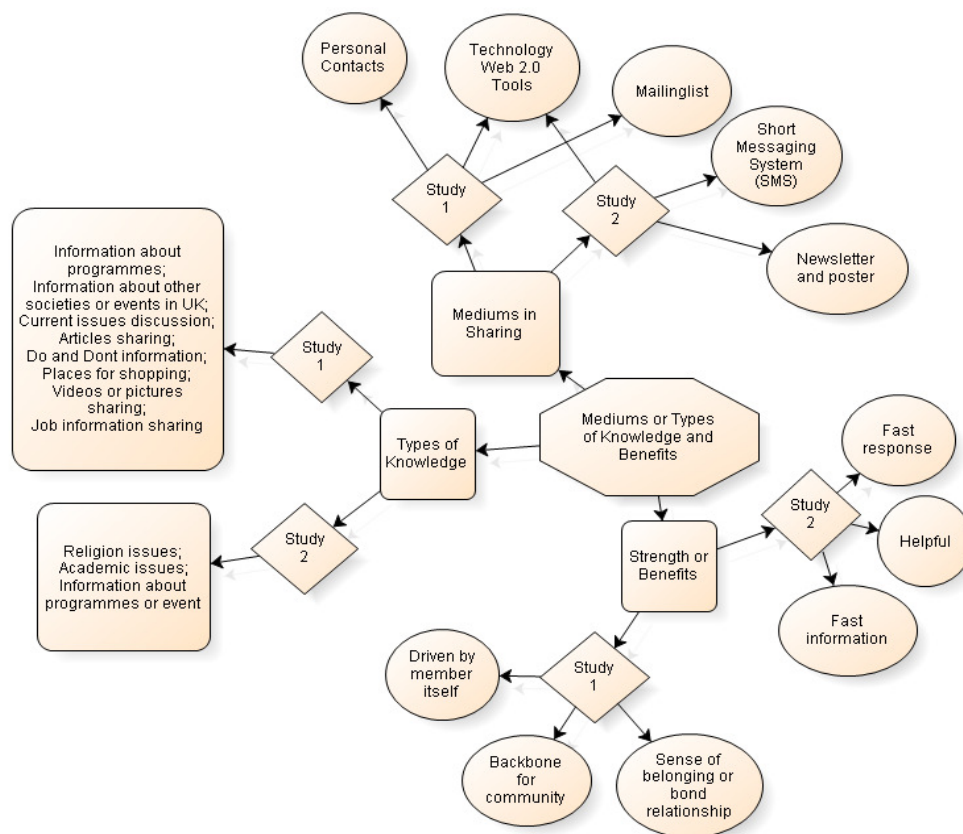

Figure 4: The details model presenting the Medium and Benefits model (Part of Final adapted Integration Model: Figure 7) and also Net Benefits model

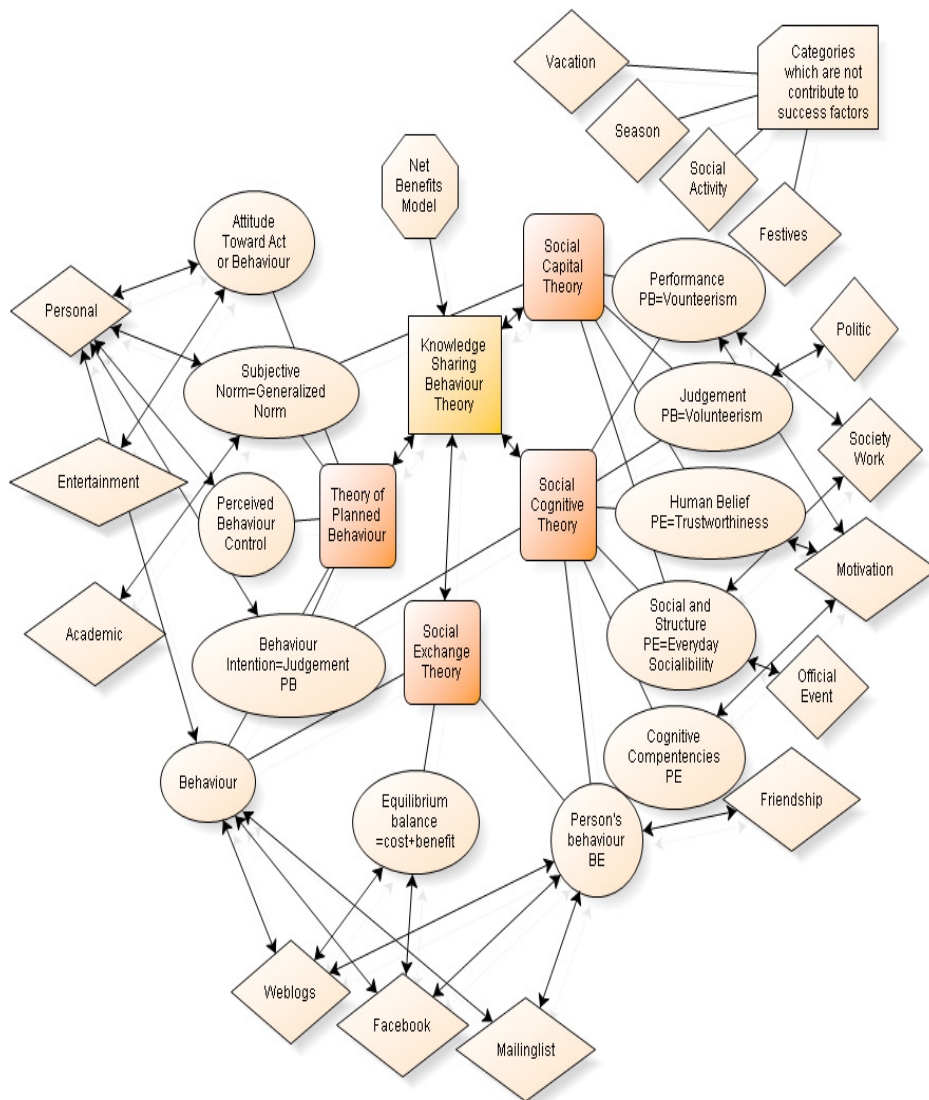

Figure 5: The details model presenting the Net Benefits models:
 2-Idea Mapping on Integration Knowledge Sharing Behaviour Theory

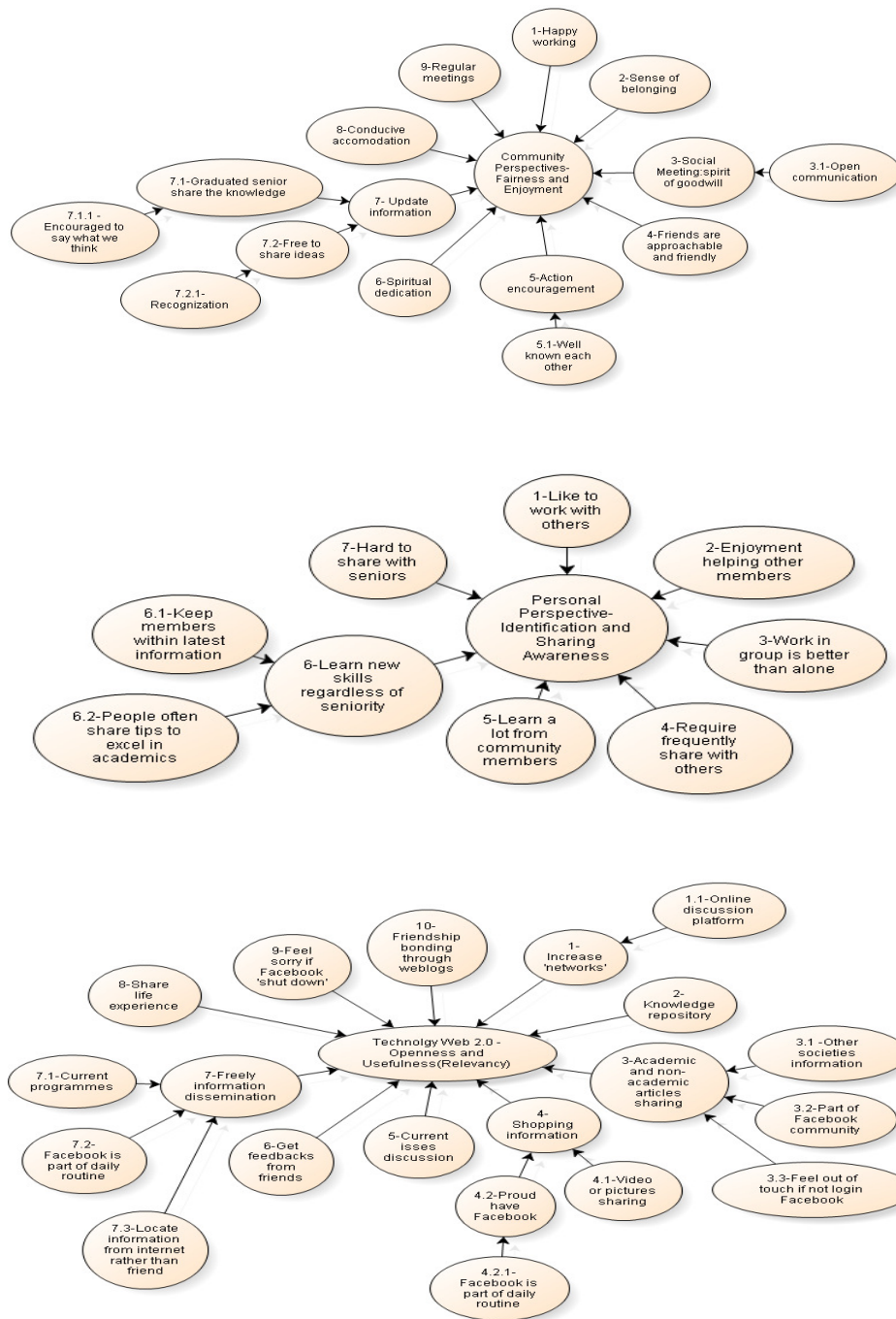

Figure 6: The 3 models presenting the Net Benefits models

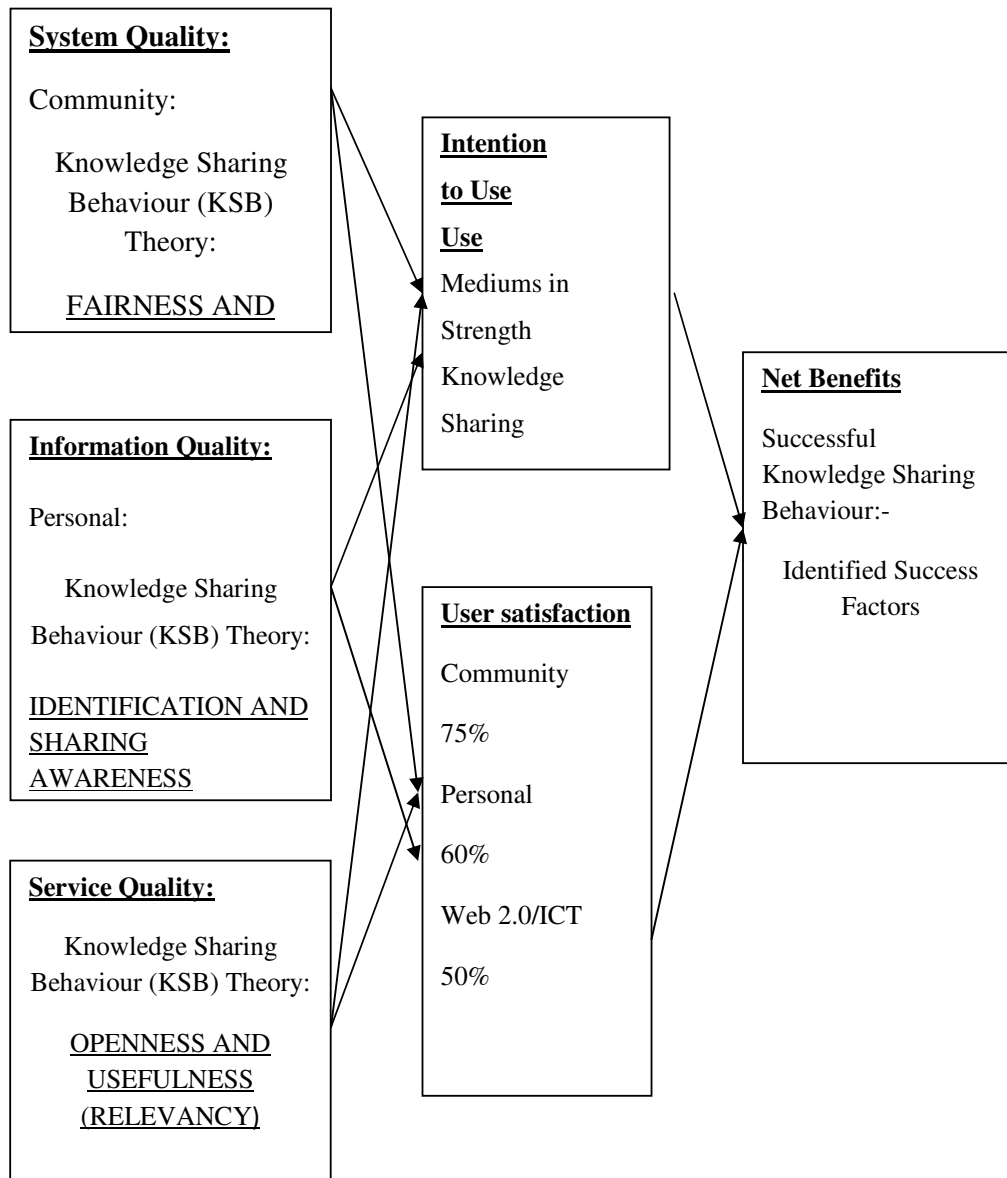

Figure 7: Final adapted Integration model: Information System (IS) Success Model (adapted from De Lone and McLean,1992,2003)

5. Contributions to knowledge from this research

This research is mainly under the Business Information Technology areas specific to Information System research areas. However, in the contribution to knowledge is divided to three perspectives:

1-Web 2.0 in Information System perspective

From the final adapted integration model; Information System (IS) Success Model, it proved the acceptance of weblogs and Facebook among the young generation-university student.

2- Knowledge sharing behaviour in knowledge management perspective

From the literature review in 2.1 about existing research in KSB in KM perspectives and the final findings through the integration-adapted model, it proved the importance in manage the knowledge in perspective of university student life.

3-Sociology and theoretical application in perspectives of student development study

From the research findings also prove the integrated knowledge sharing behaviour theory and Information System Success Model prove this two adapted and integrated theories and models are the main contribution of this research. Furthermore these adapted theories and models also are well established and widely accepted in Information System research. These theories and model is not the purely original from the researcher. However, the adaptation and amendments based on the conceptual framework and research findings from this research have been made, it can be considered as research contribution to the knowledge.

From the contribution which is seems significance in this research, there are some research implication and practical issues that have been issued in the next subchapter. It includes the potential of this research to specific and reliable applications for those are needed it.

5.1 Research Implications and Practical Issues

The variety of theories has been used to prove and used as analysis elements. The research findings can be used for the management of Higher Education Ministry in Malaysia specifically and any developing country for knowledge sharing behaviour of the university student. Since technology Web 2.0 is becomes as phenomenon to young generation, the Ministry supposedly should aware on this phenomenon.

Currently, to look after the student development within the huge number of Malaysian undergraduate students either in overseas or in local is impossible. Due on that condition, the researcher can suggest this research findings to Ministry of Higher Education for let them know what is the most antecedents for knowledge sharing behaviour that required by students. Normally the undergraduates candidate will attend the National programme under Ministry of Higher Education for ensure they are preparing the mentality to being good university student. In the module of this programme, this research finding can be adapted. From this research findings are highlighted from three perspectives, community, personal and technology Web 2.0 itself. However, the personal perspective seems as the most important factor for antecedents in knowledge sharing behaviour in student development, followed by the other two perspectives.

6. Conclusion

As conclusion, this research has been offered an account for the reasons for the widespread use of knowledge sharing behaviour based on theory and application. In this investigation, the aim is to identify the most success factors and sub factors in knowledge sharing behaviour among Malaysian undergraduates' students. in two different places. The results of this investigation show that Malaysian undergraduates' students successfully applied knowledge sharing behaviour theory in terms of knowledge sharing behaviour among them in the student's community. Furthermore, the current findings add to a growing body of literature and application on knowledge sharing behaviour theory. More information on knowledge sharing behaviour theory would help future researchers to establish a greater degree of accuracy in developing the knowledge sharing behaviour model for Malaysian undergraduates' students. In addition it shows that the knowledge and successful

functionality of the organisation should achieve an optimum of information processing (Burke, 2004).

7. References

Abdul Aziz, A. R. & Lee, K. Z.(2007). Knowledge management of foreign subsidiaries of international oil and gas contracting companies, *International Journal of Energy Sector Management*, 1(1),63 - 83.

Ahmad, H. (2004). *Process Change In Higher Education Institutions (HEIS): A Case Study Approach Proposing A Model For Successful Implementation*. Unpublished PhD, University of Bradford, Bradford.

Al-Alawi, A.I, Nayla Y.Al-M & Yasmeen F.M. (2007). Organizational Culture and Knowledge Sharing; Critical Success Factors, *Journal of Knowledge Management*, 11(2), 22-42.

Ali, H.M & Ahmad N.H. (2006). Knowledge management in Malaysian banks; A New Paradigm, *Journal of Knowledge Management Practice*, 7(3).

Burke, M. (2004). Relations Between Organisational Design and Information Processing System: A Passionate Affair or A Stormy Interlude? *Proceedings of the 12th European Conference on Information Systems-the European IS profession in the Global Networking Environment*. Turku, Finland

Burke, M.(2007). Making choices: Research Paradigms and Information Management, *Library Review*, 56(6), 476-484.

Cabrera, E. F. & Cabrera, A. (2005). Fostering knowledge sharing through people management practices. *International Journal of Human Resource Management*, 16, 720-735.

Christensen, P. H. (2007). Knowledge Sharing: moving away from the obsession with best practices', *Journal of Knowledge Management*, 11(1) 36-47.

Creswell,J.W. (1998). *Qualitative Inquiry & Research Design:Choosing among Five Traditions*, Thousand Oaks:Sage Publications.

DeLone. W.H. & Mc Lean. E.R. (1992). Information System Success: the quest for the dependent variable, *Information System Research*,3(1),60-95

- DeLone. W.H. & Mc Lean. E.R. (2003). The DeLone and McLean model of information system success: a ten year update, *Journal of Management Information Systems*, 19(4),9-30
- Easterby-Smith, M. Thorpe, R. & R.Jackson, P. (2008). *Management Research*. London: Sage Publication.
- Eppler, M. J. (2007). Knowledge Communication Problems between Experts and Decision makers; an Overview and Classification *The Electronic Journal of Knowledge Management*, 5(3) 291-300.
- Fulton, O. & Ellwood, S. (1989). *Admissions, Access and Institutional Change*. Milton Keynes, SRHE and Open University Press
- Garcia-Perez,A.& Ayres, R.(2009). Wikifailure: The Limitations of Technology for Knowledge Sharing, *10th European Conference on Knowledge Management*. Vicenza, Italy, Academic Conference Management
- Georgiadou, E. Siakas, K. & Berki, E(2006). Knowledge Creation and Sharing Through Student-Lecturer Collaborative Group Coursework, *7th European Conference on Knowledge Management*. Budapest, Hungary, Academic Conference Management
- Handzic, M. and Lagumdzija, A. (2006). Motivational Influences on Knowledge Sharing, *7th European Conference on Knowledge Management*. Budapest,Hungary, Academic Conference Management.
- Hsu, M.-H., Ju,T.L.,Yen, C.-H. & Chang C.-M. (2007). Knowledge Sharing behavior in virtual communities: The relationship between trust, self-efficacy and outcome expectations. *International Journal Human-Computer Studies*,65,153-169
- Ikhsan, S.O.S.S & Rowland, F. (2004a).Benchmarking knowledge management in a public organization in Malaysia', *Benchmarking: An International Journal*, 11(3), pp. 238-266.
- Ignacio ,R.,Helms,R.,Brinkkemper,S., & Zonnevel,A.(2009).Limitations of Network Analysis for Studying Efficiency and Effectiveness of Knowledge Sharing, *10th European Conference on Knowledge Management*. Vicenza, Italy, Academic Conference Management
- Ikhsan, S.O.S.S & Rowland, F. (2004b). Knowledge Management in public organization: A study on the relationship between organizational elements and the performance of knowledge transfer, *Journal of Knowledge Management*, 8(2), 95-111.

- Ipe, M. (2003). Knowledge Sharing in Organizations:A Conceptual Framework. *Human Resource Development Review*, 2(4), 337-359.
- Jain, K. K, Manjit, S. S. & Gurvinder, K.S. (2007). Knowledge sharing among academic staff: a case study of business schools in Klang Valley, Malaysia, *Journal of the Advancement of Science and Arts*, . 2(Science and Technology),23-29.
- Kamau, C. & Harorimana, D.(2008). Does Knowledge Sharing and withholding of Information in Organizational Commitment Affect Quality of Group decision Making? *9th European Conference on Knowledge Management*. Southampton, United Kingdom, Academic Conference Management
- Khandelwal, V. K. & Gottschalk, P. (2003). Information technology support for interorganisational knowledge transfer; an empirical study of law firms in Norway and Australia, *Information Resources Management Journal*, 16(1), 14-23.
- Kim, S. & Lee, H. (2006). The Impact of Organizational Context and Information Technology on Employee Knowledge-Sharing Capabilities, *Public Administration Review*, vol. May/June, 370-385.
- King, R. (1995). What is higher education for? Strategic dilemmas for the twenty first century university. *Quality Assurance in Education*, 3(4): 14-20.
- Kubo, I. Saka, A. and L.Pam, S. (2001).Behind the scenes of knowledge sharing in a Japanese Bank, *Human Resource Development International*, 4(4), pp. 465-485.
- Miao, Q., & Yli-Luoma, P.(2007). Interactive and Collaborative Knowledge Sharing in Web-based Learning, *8th European Conference on Knowledge Management*. Spain,Barcelona, Academic Conference Management
- Mohamad, M. (1997). Vision 2020: The Way Forward. *Malaysian Management Review*, 32(2). Retrieved 16 April 2010, from <http://resources.mim.edu.my/mmr/MA1010.htm>
- Myers, M. D. (1997). Qualitative Research in Information Systems. *MIS Quarterly* Retrieved 12 February 2009 from: www.qual.auckland.ac.nz/a
- Neto,M. & Correria, A.M. (2009). BIWiki-Using a Business Intelligence Wiki to Form a Virtual Community of Practice for Portuguese Master's Students, *10th European Conference on Knowledge Management*. Vicenza, Italy, Academic Conference Management.
- Oates, B. J. (2006). *Researching Information Systems and Computing*, London, SAGE Publications.

- Plessis, M. D. (2008). The strategic drivers and objectives of communities of practice as vehicles for knowledge management in small and medium enterprises. *International Journal of Information Management*, 28, 61-67.
- Quintero, Y. I.G. (2007). Knowledge Sharing Virtuous Cycle: Model based in Rich Pictures of Senior Executives in IT Enterprises in Bogota-Colombia. *8th European Conference on Knowledge Management*. Barcelona, Spain Academic Conference Management
- Ramirez, A. (2007). To Blog or Not to Blog: Understanding and Overcoming the Challenge of Knowledge Sharing, *Journal of Knowledge Management Practice*, 8(1)
- Rasli, A. (2005). *IT Competencies and the Conditions for Training Effectiveness: A Study on Malaysian University Clerical Workers*. Unpublished PhD, Roskilde University, Denmark.
- Ruth, F. (1998). Cost and quality of higher education. *Education Digest*. **64**: 23-30.
- Salleh, K. & Ahmad, S. N. S. (2005). KM in the local authorities-a suitable platform for e-govenment? *International Conference on Knowledge Management*. Kuala Lumpur.
- Scott, N. and Laws, E. (2006). Knowledge Sharing in Tourism and Hospitality. *Journal of Quality Assurance in Hospitality & Tourism*, 7(1/2), 1-12
- Sebreperez, P. (2009). Information System Research Methodology Ethics in Research, Lecture Notes,
- Shaari, R. (2009). *Human Resource Development And Knowledge Sharing Practices Among Academicians In Malaysian Public Universities*. Unpublished PhD, Universiti Teknologi Malaysia, Johor Bharu.
- Shah Alam, S., Abdullah, Z., Ishak, N.A & Zain, Z.M (2009). Assessing Knowledge Sharing Behaviour among Employees in SMES: An Empirical Study, *International Business Research*, 2(2), 115-122
- Sharimllah, D. Chong, R.S.C. & Binshan, L. (2007). Organisational culture and KM processes from the perspective of an institution of higher learning' *International Journal. Management in Education*, 1(1/2), 57-79.
- Smith, G. (2008). Social Networking and the Transfer of Knowledge, *9th European Conference on Knowledge Management*. Southampton, United Kingdom, Academic Conference Management
- Song, S. (2002). An Internet Knowledge Sharing System. *Journal of Computer Information Systems*, Spring, 25-30.

- Sulaiman, N.I.S. (2009). Knowledge Sharing Implementation Among Malaysian Undergraduate Students, *Poster Abstract in Proceedings in the 10th European Conference on Knowledge Management*, Vicenza, Italy,
- Szulanski, G. (1996). Exploring Internal Stickiness: Impediments to the Transfer of Best Practice. *Strategic Management Journal*, 17(winter), 27-43.
- Tedmori, S., Jackson, T., Bouchlaghem, D & Newcombe, M. (2007). Information seeking and sharing behaviour of a UK Police Force, *8th European Conference on Knowledge Management*. Barcelona, Spain, Academic Conference Management
- Wang, R. & Cassidy, J. (2008). Barriers of Knowledge Sharing in Chinese Subsidiaries: From Social-Cultural Aspects, *9th European Conference on Knowledge Management*. Southampton, United Kingdom, Academic Conference Management
- Yuen, T. J. & Majid, M. S. (2007). Knowledge-sharing patterns of undergraduate students in Singapore, *Library Review*, 56(6) 485-494.
- Zheng, W. (2005). A Conceptualisation of the Relationship between Organisational Culture and Knowledge Management, *Journal of Information and Knowledge Management*, 4(2), 113-124.

Auxetic Materials and Engineering Applications

Muhammet Uzun^{1,2}

¹*Centre for Materials Research and Innovation, University of Bolton*

²*Department of Textile Education, Marmara University, Istanbul*

Abstract

Engineering applications are growing rapidly and they need new properties of materials. Many engineering materials properties can be enhanced by negative Poisson's ratio. Negative ratio (auxetic) materials have the potential to give better characteristics to technical textile and composite applications. Materials properties that can be related to Poisson's ratio include acoustic behaviour, superior energy absorption (ultrasonic, sonic, impact), damping improvement, indentation resistance, double curvature, porosity/permeability variation with strain, thermal shock resistance, fracture toughness, shear modulus. These are all predicted to be enhanced for negative Poisson's ratio materials.

Keywords:

Auxetic materials, negative Poisson's ratio, auxetic fibre spinning, composites

1. Introduction

Auxetic materials (Evans et al., 1991) (those with a negative Poisson's ratio, Figure 1A) have an extraordinary behaviour in that they get fatter when they are stretched, and become thinner when compressed, compared to conventional materials (positive Poisson's ratio, Figure 1B). Poisson's ratio (ν) is the ratio of contraction or transverse strain, to the extension or axial strain. The Poisson's ratio of stable, isotropic, linear elastic material can not be less than -1.0 or greater than 0.5 due to the requirement that the elastic modulus, the shear modulus and bulk modulus have positive values. Most materials have positive Poisson's ratio (0.0-0.5) and some materials have negative Poisson's ratio, for example some polymer and metallic (Friis et al., 1998, Choi et al., 1992a and 1995b, Lakes et al., 1993) foams (Lakes, 1987), certain rocks and minerals (Burke, 1997) polymeric fibres (Alderson et al., 2002) honeycombs (Whitty et al., 2002, Gibson et al, 1997a and 1982b and composite laminates (Herakovich, 1985).

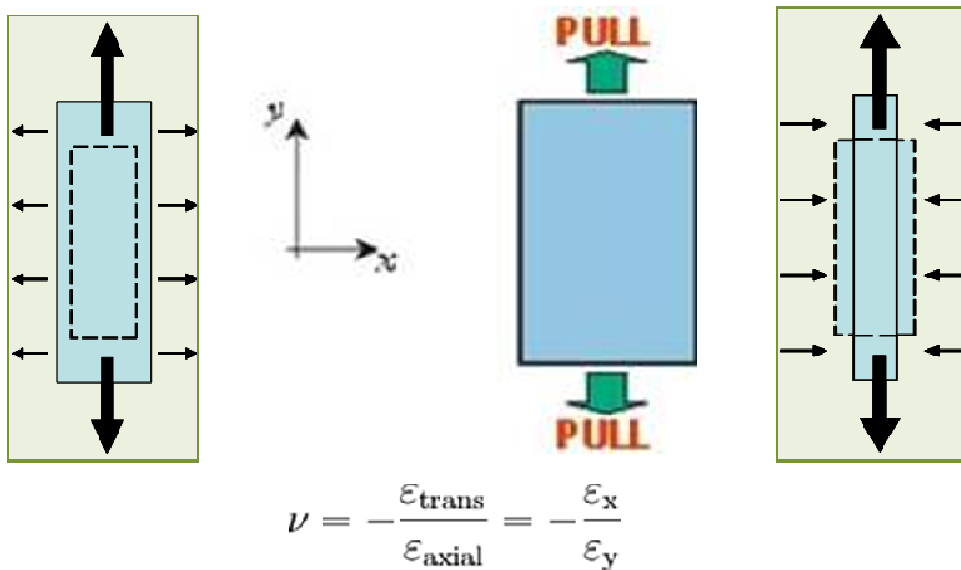

Fig 1A: Negative Poisson's Ratio

Fig 1B: Positive Poisson's Ratio

Source: <http://home.um.edu.mt/auxetic/>

2. History of auxetic Materials

The term "Auxetic" was used by Evans for the first time in 1991 (Evans et al., 1991). The term's origin is The Greek word 'Auxetos; Auxesis' which means 'that which is able to increase; grow'. Auxetic is a new term but negative Poisson's ratio materials have been known for over 100 years, although they have not been given too much attention until recently.

3. Classification of Auxetic Materials

The classification of Auxetic materials ranging from macroscopic down to the molecular levels including natural and man-made auxetic materials, are shown in figure 2.

Natural Auxetic materials include for example, iron pyrites (Love, 1944), many cubic elemental metals (Lakes, 1987), single crystals of arsenic (Gunton et al., 1972) and cadmium (Li, 1976), and α - cristobalite (Yeganeh et al., 1992). Natural Auxetic

materials and structures also occur in biological systems, for example, salamander skin (Frohlich et al., 1994), cat skin (Veronda, 1970), cow teat skin (Lees et al., 1982), load – bearing cancellous bone from human shins and bone tissues (Williams, 1982).

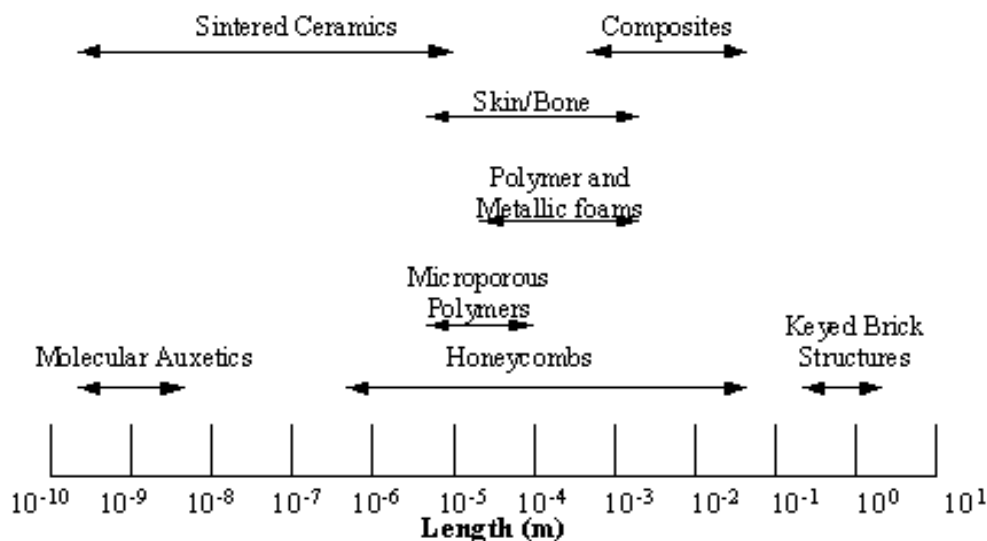

Fig 2: Auxetic materials and structures from the macroscopic down to the molecular level (Alderson, 1999)

Auxetic behaviour at the molecular level in iron pyrites (Love, 1944) was first observed in the first half of the twentieth centuries. Ledbetter found evidence of auxetic behaviour in $\text{YBa}_2\text{Cu}_3\text{O}_7$ (Ledbetter 1991), arsenic (Gunton et al., 1972) and cadmium (Li, 1976) at the molecular level. Baughman (Baughman et al., 1998) and co-workers at AlliedSignal in 1998 revealed that 69% of cubic elemental metals and some face-centred cubic rare gas solids are Auxetic when stretched along a specific direction. Baughman et al. suggested that electrodes made from such auxetic metal would give a two-fold increase in piezoelectric device sensitivity.

Researchers at Stony Brook found that the α -cristobalite (Milstein et al., 1979 and Yeganeh et al., 1992) polymorph of crystalline silica was auxetic. Firstly, the proposed mechanism for auxetic behaviour in α -cristobalite was the cooperative rotation of the SiO_4 (Keskar et al., 1992) tetrahedral units making up the α -cristobalite molecular structure.

Baughman has proposed an alternative molecular network called 'twisted-chain auxetic' (Baughman et al., 1993). The mechanism for the auxetic behaviour is a result of specific shear deformation in helical polyacetylene chains formed from adjacent chains in a coupled polydiacetylene chain network. This twisted-chain auxetic is likely to possess a negative thermal expansion co-efficient, expand under pressure and exhibit shape memory behaviour. Moreover, it was suggested that these materials could actually have interesting electrical and optical properties, offering potential end-uses as electro-mechanical actuators. Yuejin Guo and William Goddard (Guo et al., 1995) predicted that α and β phases of carbon nitride were auxetic. Recently, Griffin (He et al., 1998) has also proposed auxetic behaviour in a main-chain liquid crystalline polymer. Each polymer chain consists of a series of rods interconnected by flexible 'spacers'. The auxetic behaviour occurs when the chains are stretched, resulting in the laterally attached rods rotating perpendicular to the chain, causing an increase in the lateral inter-chain separation.

An example of a macro-scale auxetic structure is to be found in the graphite cores (Evans et al., 2000 and Muto et al., 1963) in magnox nuclear reactors (Key-Brick Structure) (Bailey et al., 1961 and Poulter, 1963), designed and built in the 1950's. These structures were not designed specifically to be auxetic, but were designed to withstand the horizontal shear forces generated during earthquakes, and to allow free movement of the structure in response to thermal movements between the graphite core and steel supporting structures as well as expansion and shrinkage of the graphite during exposure to radiation.

Re-entrant honeycomb Structures, the first auxetic cellular structures were proposed in 1982 as a 2-D silicone rubber re-entrant honeycomb (Whitty et al., 2002, Gibson et al., 1997a and 1982b, with deformation occurring by flexing of the ribs. When the ordinary honeycomb is stretched in the y- direction, the cells expand in the y- direction and close in the x- direction. Macroscopic structured forms (in two and/or three dimension) consisting of rods, springs, and sliders, have also been devised to give a negative Poisson's ratio (Kolpakov, 1991 and Almgren 1985).

Roderic Lakes (Lakes, 1987, Muto et al., 1963, Lakes et al., 1993 and Alderson, 1999) converted synthetic polyurethane foam from its conventional, positive Poisson's ratio form to one having a negative Poisson's ratio by a relatively simple

process of heating and triaxially compressing the foam cells. These isotropic three-dimensional polymeric and, subsequently, metallic foams (Friss et al., 1998, Choi et al., 1995(a) and 1995(b), Lakes et al., 1993) were observed to possess Poisson's ratio as low as -0.7 to -0.8 . Auxetic foams have potential applications in the fields related to packaging, sound insulation (Alderson, 1999), shock absorption (Alderson et al., 1999), air filtration (Alderson et al., 1999) and also in the design of press-fit fasteners (Choi et al., 1992). Auxetic honeycombs and foam were used to demonstrate synclastic (doubly curved) curvature, as opposed to the anticlastic (saddle shape) curvature adopted by positive Poisson's ratio panels when subjected to out of plane bending (Donoghue et al., 1991 and Clarke et al., 1994). Sandwich panels containing auxetic honeycombs or foam have potential applications in, for example, curved body parts for cars and aircrafts (e.g. aircraft nose-cones) due to the possibility of reducing the need for expensive and damaging machining techniques during production (Evans et al., 2004).

Classical lamination theory (Gibson, 1994) has shown that fibre reinforced laminate composites could theoretically have negative in-plane and through-the-thickness Poisson's ratios (Herakovich, 1985). The sign and magnitude of the Poisson's ratio is determined by the stacking sequence of the laminate layer in the composite, as well as the type of fibre and matrix material.

4. Auxetic Materials Wear Resistance Properties

The relationship between shear modulus (G), Young's Modulus (E) and Poisson's ratio for isotropic materials is

$$G = \frac{E}{2(1 + \nu)}$$

(1)

As the Poisson's ratio approaches -1 , the material becomes difficult to shear. Also the hardness, H , is related to Poisson's ratio as:

$$H \propto (1 - \nu^2)^{-x}$$

(2)

where x is a value which depends on the type of indentation. Equation 2 demonstrates that hardness will be enhanced for an auxetic material ~ -1 . This enhancement is also shown schematically in figure 4.

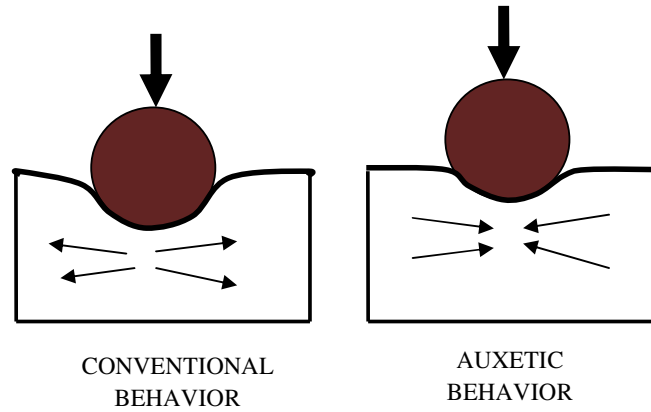

Fig 3: Indentation resistance of auxetic by comparing to conventional structures

Abrasive wear occurs when material is removed from a surface by contact with hard particles. Adhesive wear occurs when a hard rough surface slides across a softer surface. It is accepted that, auxetic material should have improved abrasion wear resistance due to enhanced fracture toughness. In the case of adhesive wear, Archard (Bakar et al., 2008) proposed that wear rate (displacement per unit time) $\dot{\Delta}h$ for general applications could be given in the following expression (Equation 3), where Δh is the wear displacement, t is the sliding time, k is the wear coefficient, H is the hardness of tested material, P is the applied pressure and V is the sliding speed.

$$\dot{\Delta}h = \frac{\Delta h}{t} = \frac{k}{H}PV$$

(3)

Enhanced adhesive wear resistance is, therefore, expected in auxetic materials by virtue of their enhanced hardness potential.

Improved wear resistance causes an enhancement in the abrasion resistance such as ropes, cords and fishnets. Being resistant to abrasive wear should also be useful in other fibre applications where abrasion occurs, such as upholstery fabrics for furniture and automotive seats. Therefore, it is suggested that the enhanced wear resistance of auxetic materials should enhance the performance of materials and their life of usage.

5. Engineering Applications

5.1. Composites Applications

Recently, textile fibre and structure reinforced composites have been extensively used in many fields of industry such as Aircraft and Military Applications, Marine Applications, Space Application and Infrastructure (Mallick, 1985). Textile reinforced composites can exhibit many benefits when compared with metals or ceramics, such as tenacity, elasticity, thermal resistance, strength, rigidity and low density. The composite industry needs new advanced material for improving composite structures. Auxetic materials have the potential to give new characteristics to textile structures and composite applications through enhancement in mechanical properties such as indentation resistance, fracture toughness (Choi et al., 1992), sound absorption (Lakes, 1987), and thermal shock resistance (Alderson et al., 2005, Evans et al., 1991). Composites, in the term composite material, signify that two or more materials are combined on a macroscopic scale to form a useful third material. Thus a composite is a product formed by intimately combining two or more discrete physical phases, usually a solid matrix and a fibrous material (Jones, 1999). Almost all types of textile structures (fibres, yarns and fabrics) have been used in composite reinforced materials and textile reinforced composite structures have many advantages. Fibre reinforced composites are the major group above all other composites. Some of the properties that can be improved by forming a composite material are

- ❖ Strength
- ❖ Stiffness
- ❖ Corrosion resistance
- ❖ Wear resistance
- ❖ Drape
- ❖ Weight
- ❖ Fatigue life
- ❖ Temperature-dependent behaviour
- ❖ Thermal insulation
- ❖ Thermal conductivity
- ❖ Acoustical insulation

Polypropylene (PP) is used extensively by the automotive and aircraft industries because of its relative low cost, low density ease of processing and inert nature

(Barkoula et al., 2007 and Mckown et al., 2007). In addition, PP can be used as a matrix material because of its low cost and ease of recycling (Alcock et al., 2009).

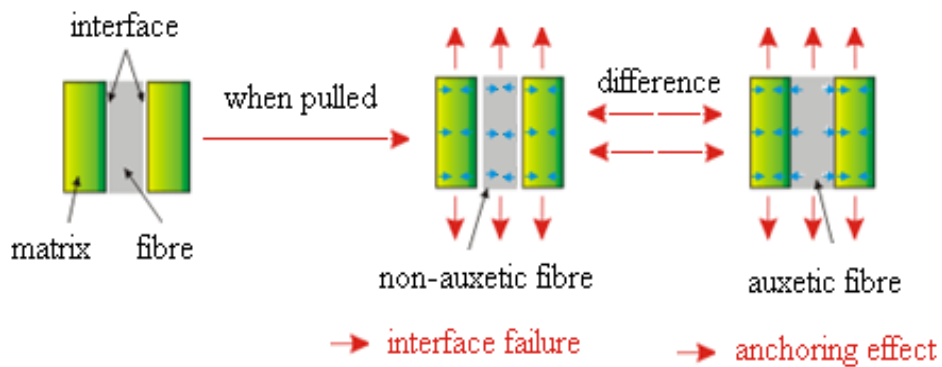
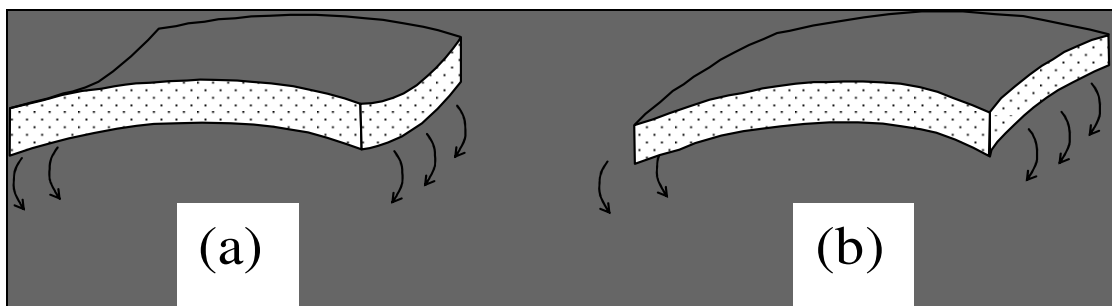

Fig 4: Pullout Resistance (Anchoring)
 Source: <http://home.um.edu.mt/auxetic/>

Previous works have showed that Auxetic materials can stand more than twice to the maximum load of the non-Auxetic materials. This property is important for Textile reinforced composites.

Advanced composite materials

- *Improved drape ability*
- *Better resistance to indentation and impact*



Anticlastic
 Fig 5: (dome shape) Curvature in Auxetic plate

Synclastic
 (saddle shape) Curvature in Conventional plate

6. Auxetic and Non-Auxetic Fibres Fabrication

The fibres have been produced by the melt spinning technique using established processing parameters (Simkins et al., 2008 and Alderson et al., 2002). The most common type of melt extruder for polymers is a single screw extruder consisting of an Archimedean type screw contained within a barrel heated over a wide temperature range (typically between 150⁰C and 300⁰C) The melt extruder consists of a hopper, screw and a die or spinneret (Figure 6).

The screw of the extruder assists (Strong, 2000) in conveying the material through the extruder imparting the energy to melt the polymer and mix the polymer uniformly. It also assists in pumping the molten polymer at a constant rate. The polymer material then passes through the die, which consists of a spinneret. The main function of the die is to give the required shape to the extruded polymer. Finally, the extrudate undergoes orientation and subsequent heat treatment processes before it is wound on to a package.

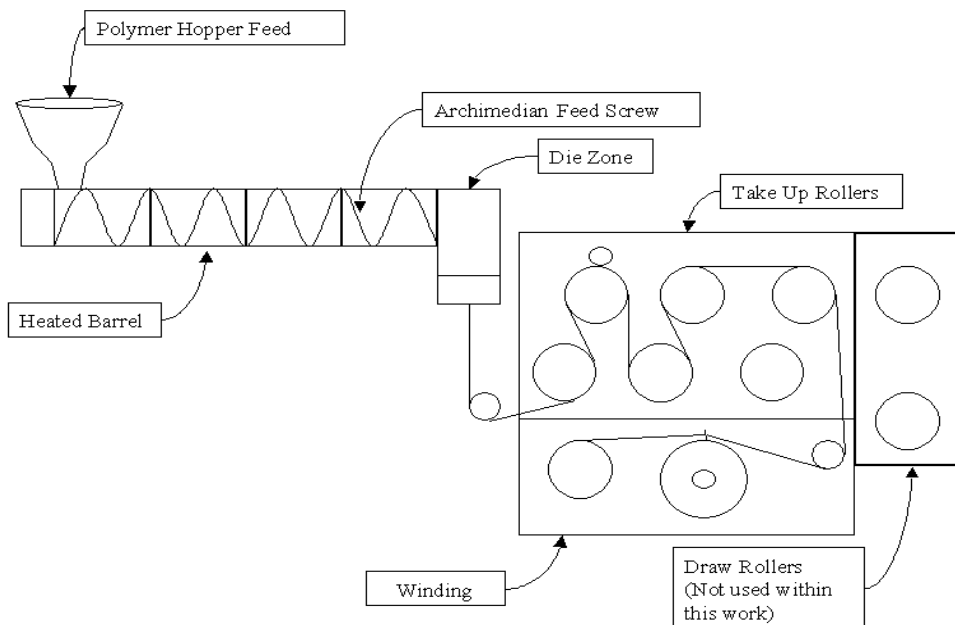

Fig 6: Melt spinning extruder (Ravirala, 2006)

A continuous melt extrusion process has previously been developed to produce the first known auxetic material in fibre form. The auxetic fibre was made from polypropylene powder (Coathylene PB0580). This powder was identical to that used in previous successful production of auxetic PP cylinders. A melt spinning process

was performed using a melt extruder consisting of an Archimedean type screw with 3:1 compression ratio, 25.4mm screw diameter, and thermostats for each of five temperature zones. Powder was fed through a hopper into the barrel and fed through the extruder by the action of the screw, with a flat temperature profile of 159⁰C in all zones of the extruder. The extruder was operated at a 10 rpm (1.05rad.s⁻¹) screw speed and 2 mpm (0.03m.s⁻¹) take-up speed and a 40–filament die with each hole having a diameter of 550µm was fitted. The extruded fibres were cooled in air after exiting the die before winding on the rollers (Simkins et al., 2008 and Alderson et al., 2002). In the auxetic fibre producing process, the cooling bath stage is not employed.

7. Characterisation of fibres Poisson`s ratio

Characterisation of the fibre`s Poisson ratio has been done using a MESSPHYSIK ME 46 video extensometer in combination with a micro tensile testing machine in order to examine the auxetic behaviour of the fibres. A software package was developed by Messphysik GmbH that measures strains and/or extensions on standard specimens. The video extensometry is used to measure the strains in both axial and transverse directions, and hence the Poisson`s ratio of the fibres can be determined. Mechanical testing including Poisson`s ratio determination, Young Modulus determination and tensile strength of both auxetic and non-auxetic fibres can also be done.

8. Technical Textile Applications

- **Medical Textiles (Medtech)**



Fig 7: Structural changes of an Auxetic bandage **Source:** www.azom.com

Effective porosity with strain and Impregnability can be used in medical textile applications. Auxetic materials can be impregnated due to their changeable pore sizes under a strain. This property can be used for medical textile applications. Prosthetic materials, surgical implants, suture/muscle/ligament anchors and a dilator to open up blood vessels during heart surgery are all possible applications.

- **Sports Textiles (Sporttech)**

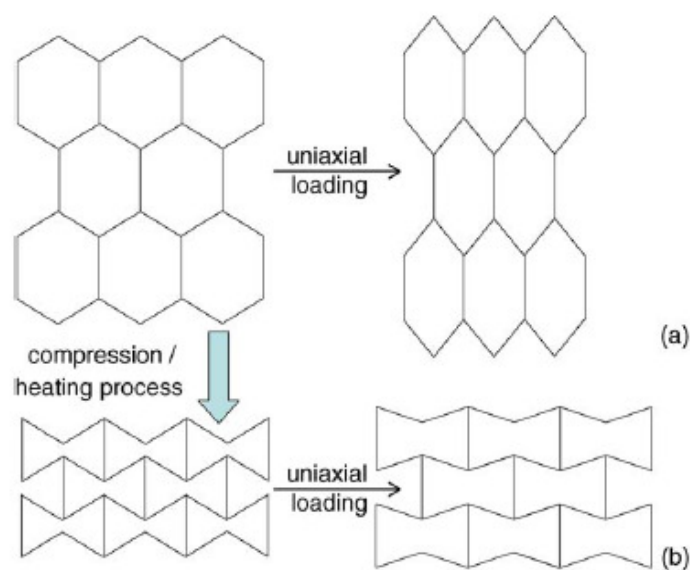

Fig 8: Air Permeability/Breath ability (Grima et al., 2006)

Change of the pore sizes of an Auxetic material to allow air circulation. Breath ability is one of the most important features of fabrics for wearers' comfort. Especially, this property is very important for sport wears. To be able to breathable, fabric should allow air circulation and to be able to provide air circulation, fabric should have a porous structure. Bigger porosity structure, fabric becomes more permeable to the air and also more breathable.

9. Other textile applications

- ❖ PP fibres are used commonly in Non-Woven fabric; Auxetic PP can be used to give better wear resistance. All textile structures especially non-woven fabrics

can be fabricated with auxetic fibres and can be employed as medical, filters, geo-tech etc.

- ❖ Auxetic materials can be used as bullet proof clothes and blast curtains (Rodie, 2010)
- ❖ Industrial cords have been produced with auxetic behaviour (Rodie, 2010)

Acknowledgements

The author would like to thank Prof Andy Alderson and Prof Kim Alderson for supports during the project.

10. References

- Alderson, K.L. Alderson, A. Smart G. Simkins V.R. and Davies P.J., 2002. Auxetic Polypropylene Fibres Part 1- Manufacture and Characterisation. *Plastics, Rubber and Composites*, 31 (8)
- Alderson, A., 1999. A triumph of lateral thought. *Chemistry & Industry*, May 17, pp. 348–391.
- Alderson, A. Evans, K. E. and Rasburn, J., 1999. Smart membrane. Patent WO 99/22838.
- Alderson, K. Alderson, A. 2005. Expand Materials and Applications: Exploiting Auxetic Textiles. *Technical Textile International*, September.
- Alcock, B. Cabrera, N.O. Barkoula, N.M. and Peijs T., 2009. Direct Forming of All-Polypropylene Composites Products from Fabrics made of Co-Extruded Tapes. *Appl Compos Mater*, 16 pp.117–134.
- Almgren, R.F., 1985. An isotropic three-dimensional structure with Poisson's ratio-1. *Journal of Elasticity*, 15, pp.427-430.
- Barkoula, N.M. Alcock, B. Cabrera, N. and Peijs, T., 2007. Fatigue Properties of Highly Oriented PP Tapes and All-PP Composites. *Composites Science and Technology*, 67, pp. 2061-2070.
- Burke, M., 1997. A Stretch of the Imagination. *New Scientist*, 154(2085):36.
- Baughman, R.H. Shacklette, J.M. Zakhidov, A.A. and Stafstrom, S., 1998. Negative Poisson's ratio as a common feature of cubic metals. *Nature*, pp.392:362–365.
- Baughman, R.H. and Galvao, D.S., 1993. Crystalline networks with unusual predicted mechanical and thermal properties. *Nature*, pp:365:735–737.

Bakar, A.R.A Li, L. James, S. and Ouyang, H., 2008. Wear Simulation and Its Effect on Contact Pressure Distribution and Squeal of a Disc Brake. Department of Engineering, The University of Liverpool, UK.

Bailey, R.W. and Cox, H.A., 1961. Structural design and development of graphite reactor cores. *GEC Journal*, 28, pp.72–78.

Choi, J.B. and Lakes, R.S., 1992. Non-linear properties of metallic cellular materials with a negative Poisson's ratio. *Journal of Materials Science*, 27, pp.5375–5381.

Choi, J.B. and Lakes, R.S., 1992. Nonlinear properties of polymer cellular materials with a negative Poisson's ratio. *Journal of Materials Science*, 27, pp.4678–4684.

Choi, J.B. and Lakes R.S., 1995. Nonlinear analysis of the Poisson's ratio of negative Poisson's ratio foams. *Journal of Composite Materials*, 29, pp.113–128.

Choi, J.B. and Lakes R.S., 1991. Design of a fastener based on negative Poisson's ratio foam. *Cellular Polymers*, 10, pp.205-212.

Clarke, J.F. Duckett, R.A. Hine, P.J., Hutchinson, I.J. and Ward, I.M.. 1994. Negative Poisson's ratio in angle-ply laminates: Theory and experiment. *Composites*, 25, pp.863-840.

Donoghue, J.P. and Evans, K. E. 1991. In *ICCA 8*. (Eds S.W. Tsai, G.S. Springer) SAMPA, pp. 2, Covina, CA.

Evans, K.E. Nkansah, M.A. Hutchison, I.J. and Rogers, S.C., 1991. Molecular Network Design. *Nature* 353, pp.124.

Evans, K.E. Donoghue, J.P. and Alderson, K.L., 2004. The design, matching and manufacture of Auxetic carbon fibre laminate. *Journal of Composite Materials*, 38, pp.95–106.

Evans, K.E. Nkansah, M.A. and Hutchingson I.J., 1991. Modelling negative Poisson's ratio effects in network Embedded composites. *Acta Metallurgical Materials*, 766, pp.1–10.

Evans, K.E. and Alderson A., 2000. Auxetic materials: Functional materials and structures from lateral thinking!. *Advanced Materials*, 12, pp.617–628.

Friis, E.A. Lakes, R.S. and Park, J.B., 1998. Negative Poisson's ratio polymeric and metallic materials *Journal of Materials Science*, 23, pp.4406–4414.

Frohlich, L.M. LaBarbera, M. and Stevens, W.P., 1994. Poisson's ratio of a crossed fibre sheath: The skin of Aquatic salamanders. *Journal of Zoology*, London, pp.232:231–252

- Gibson, L.J. and Ashby, M.F., 1997. Cellular solids: Structure and Properties. 2th ed. Cambridge: Cambridge University Press.
- Gibson, L.J. Ashby, M.F. Schajer, G.S. and Robertson, C.I., 1982. The mechanics of two-dimensional cellular solids. CI proceedings of Royal Society London, 382-A, pp.25–42.
- Gibson, R. F., 1994. Principles of composites material mechanics. New York: McGraw Hill International Editions Engineering Mechanics Series.
- Grima, J. Gatt, R. Ravirala, N. Alderson, A. Evans, K.E., 2006. Materials Science and Engineering: A, [423](#), 214.
- Guo, Y.J. and Goddard, W.A., 1995. Is carbon nitride harder than diamond - no, but its girth increases when stretched (negative Poisson ratio). Chemical Physics Letters, 237, pp.72–76.
- Gunton, D.J. and Saunders, G.A., 1972. The Young's modulus and Poisson's ratio in arsenic, antimony and bismuth. Journal of Materials Science, 7, pp.1061–1068.
- Herakovich, C.T., 1985. Composite laminates with negative through-the-thickness Poisson's ratio Journal of Composite Materials, 18, pp.447–455.
- He, C. Liu, P. and Griffin A.C., 1998. Toward Auxetic materials through molecular design. Macromolecules, 31, pp.3145–3147.
- Jones, R.M., 1999. Mechanics of Composite Materials. 2th ed. New York: Sega Pub.
- Rodie, J.B., Managing Editor, 2010.
- [http://www.textileworld.com/Articles/2010/May/May_June_issue/Departments/QFO M_The_Auxetic_Effect.html](http://www.textileworld.com/Articles/2010/May/May_June_issue/Departments/QFO_M_The_Auxetic_Effect.html) [Accessed 21 July 2010]
- Keskar, N. and Chelikowsky, J.R., 1992. Negative Poisson's ratios in crystalline SiO₂ from first-principles calculations. Nature, 358, pp.222–224.
- Kolpakov, A.G. 1991. On the determination of the averaged moduli of elastic grid works. Prikl Matem Mekhan, 59, pp.969–977.
- Lakes, R.S. and Elms, K.J., 1993. Indentability of conventional and negative Poisson's ratio foams Journal of Composite Materials, 27, pp.1193–1202.
- Lakes, R.S., 1987. Foam structures with a negative Poisson's ratio. Science, 235, pp.1038–1040.
- Lakes, R.S. and Elms, K.J., 1993. Indentability of conventional and negative Poisson's ratio foams. Journal of Composite Materials, 27, pp.1193–1202.
- Love, E.H., 1944. A treatise on the Mathematical theory of Elasticity. 4th ed. New York: Dover

- Li, Y., 1976. The anisotropic behaviour of Poisson's ratio, Young's modulus and shear modulus in hexagonal materials. *Physica Status Solidi Series A*, 38, pp.171–175.
- Lees, C., Vincent, J.F.V. and Hillerton, J.E. 1991. Poisson's ratio in skin" *Bio-Medical Materials and Engineering*, 1, pp.19–23.
- Ledbetter, H. and Lei, L., 1991. Poisson's ratio of porous and micro cracked solids: Theory and application to oxide superconductors. *Journal of Materials Research*, 6, pp.2253–2255.
- Milstein, F. and Huang, K. 1979. Existence of a negative Poisson's ratio in fcc crystals. *Physical Review B*, 9, pp.2030–2033.
- Muto, K. Bailey, R.W. and Mitchell, K.L., 1963. Special requirements for the design of nuclear power stations to withstand earthquakes. *Proc. Inst.Mech. Eng.*, 177, pp.155–203.
- Mallik, P.K., 2008. *Fibre-Reinforced Composites*. 3rd ed., New York, CRC Press.
- McKown, S. Cantwell, W.J. 2007. Investigation of Strain-rate Effects in Self-reinforced Polypropylene Composites. *Journal of Composite Materials*, 41.
- Poulter, D.R., 1963. *The design of gas-cooled graphite-moderated reactors*. London: Oxford University Press
- Ravirala, N., 2006. *Fabrication, Characterisation and Modelling of an Expanded Range of Auxetic Polymeric Fibres and Films*. PhD Thesis, June, University of Bolton.
- Simkins, V.R. Ravirala, N. Davies, P.J. Alderson, A. Alderson, K.L., 2008. An experimental study of Thermal Post-Production Processing of Auxetic Polypropylene Fibres. *Physica Status Solidi*, pp.1-8
- Strong, A., 2000. *Plastics: Materials and Processing*. 11th London: Prentice Hall.
- Veronda, D.R. and Westmann, R.A., 1970. Mechanical characterisation of skin-finite deformations. *Journal of Biomechanics*, 13, pp.111–124.
- Whitty, J.P.W. Nazare, F. and Alderson, A., 2002. Modelling the effects of density variations on the in-plane Poisson's ratios and Young's moduli of periodic conventional and re-entrant honeycombs – part 1:rib thickness variations. *Cellular Polymers*, 21, pp.69–97.
- Williams, J.L. and Lewis, J.L., 1982, Properties of an anisotropic model of cancellous bone from the proximal tibial epiphysis. *Journal of Biomechanical Engineering*, 104, pp.50–56.

Yeganeh-Haeri, Y. Weidner, D.J. and Praise, J.B., 1992. Elasticity of α -cristobalite: A silicon dioxide with a Negative Poisson's ratio. *Science*, 257, pp.650–652.

Auxetic Malta Group, <http://home.um.edu.mt/auxetic/> [Accessed on 13 November 2009].

Growing Ethnopolitical Conflict and the Challenge of ‘One Nigeria’: Politics of State Building in a Multiethnic Society, 1960-2010

Ali Simon Bagaji Yusufu, *University of Exeter*.

Abstract

Since October 1, 1960 when Nigeria attained political independence, it has been witnessing a steady growth of ethnopolitical and religious crises in its body politics. The central concern of this paper is that, ethnopolitical conflicts are posing great challenge to Nigeria’s unity, sovereignty and legitimacy that may lead to its consequential collapse. The worry of this paper is that, rather than diminishing after over five decades of political independence, ethnopolitical conflict has since the 1990s not only become more ferocious and alarming, but are also shifting from ethnic accommodation to ethnic self-determination. This paper is part of an ongoing PhD research that seeks to understand the nature and dynamics of ethnopolitical conflicts in Nigeria from 1960 to date.

Keywords

Ethnopolitics, Ethnopolitical Conflict, Ethnic self-determination, One Nigeria, Multiethnic society.

1. Introduction

Before and shortly after Nigeria attained political independence from British colonization in 1960, many nationalist leaders denounced threats of ethnicity and regionalism. Indeed, Nigerians considered themselves as belonging to one sovereign and indivisible country irrespective of ethnic identity. The unity slogan at the time was ‘One Nigeria’. However, immediately the British colonial administration ended, the paradox of the situation is the reality on the ground that many of the proclaimed anti-regionalist and anti-ethnicist leaders themselves soon started to use ethnicity and regionalism as weapon to exclude, marginalize and repress those in opposition and those they perceived as enemies. The consequences have been that, since 1960 to date, in the process of state building, Nigeria has witnessed series of ethnopolitical crises.

In order to achieve unity in diversity, various Nigerian governments have taken series of measures to constructing a pan-Nigerian identity, based on equality, common political practice, operating the same law and having a cosmopolitan outlook (Kazah-Toure, 2007). Despite the series of measures undertaken by successive civilian and military governments, it appears unity has remained largely elusive. This is because for instance, beginning from the 1990s to date, there has been an increasing surge from ethnic accommodation to self-determination (Osaghae, 2001). A major thrust of the above analysis is that, of the five decades of postcolonialism, October 1, 1960 to May, 2010, Nigerian governments have been involved in one way or the other in state building, a major part of it has been committed to handling protracted ethnopolitical and religious crises. This negative development is putting to test its sovereignty, socio-political and economic stability.

A worrying concern of this paper is that, in contradistinction to the pre-independence unity in diversity slogan of one Nigeria and recently series of Pan-Nigeria identity campaigns embarked upon by successive governments, ethnic identities and ethnic nationalism is gaining strength and even a degree of legitimacy in Nigeria. In an attempt therefore to come to terms with the phenomenon of ethnopolitical conflict in Nigeria, this paper throws up a number of questions as follows: Are the ethnopolitical conflicts as a result of the structural, political, economic, social and cultural differences? Are the ethnopolitical conflicts borne out of the need to emancipate an ethnic group from internal colonialism, especially as it is related to distributive justice of the resources of the state? What is the role of government in power in the production and reproduction of ethnopolitical conflicts? From the foregoing therefore, this paper is an exploration into the nature, development, crystallization and dynamics of the ethnopolitical conflicts in Nigeria.

2. Ethnopolitical Conflicts in Nigeria: Origin and Transformation

In the course of contemporary historical and political processes in Nigeria, it has experienced major ethnopolitical conflicts that are threatening its sovereignty and legitimacy. For instance, conflicts generated by the politicization of ethnic identity have become ferocious and alarming especially since the 1990s. To be specific, Ikelegbe (2005:490) states that, 'communal, ethnic and ethno-religious politicization

and mobilization have increased since democratization opened up political space in 1999'. Thus, as a result of the intensification of ethnicity, Nigeria has witnessed a record political unrest, which includes three year strife, the collapse of three republics and six successful military coups, coupled with frequent religious and other forms of ethnic schism (Babawale, 2003). All of the above contemporary negative developments are contrary to the idea of One Nigeria Unity that was held by all and sundry before and shortly after independence.

In order to properly comprehend the crystallization of ethnopolitical conflicts in contemporary Nigeria, it is important to begin in pre-colonial Nigeria. This is because, although the colonial period was relatively brief in Nigeria, ethnic groups in Nigeria and the identities claimed for them attained tremendous transformation and reconstruction during the colonial and post colonial Nigerian state. To facilitate effective political administration of Nigeria, the British used the system of indirect rule. The implication of indirect rule is that, for a period of about four hundred years, and especially from 1900, the British colonial administration was felt in Nigeria with different effects. For instance, whereas the southern parts were more effectively colonized particularly through western education and Christian missionary activities, the Islamic religion and way of life made northerners conservative, suspicious, and resistant to western forms of education as well as to other forms of religions. The inference one can derive from the above is that, socially and politically there has been deep differences between the major tribal groups- they do not speak the same language and they have highly divergent customs and ways of life and they represent different stages of culture (Uroh, 1992).

Even with the awareness of these obvious differences, the British colonial regime still created the Nigerian-nation state, and administered it through a policy of indirect rule, which encouraged the separate development of the constituent ethnic units that make up Nigeria without encouraging the Nigerianess of the whole (Imobighe, 2003). The above assertion was confirmed in a comment made by a one time Governor General of Nigeria, Arthur Richard who was quoted by Uroh (1992:191), when he said that, 'it is only the accident of British suzerainty which has made Nigeria one country' and that, it is still far from being one country or one nation, socially or even economically'. The above statement has been put most forcefully by two of Nigeria's

leading statesmen. In 1947, Chief Obafemi Awolowo, founder and leader of the Egbe Omo Oduduwa and the Action Group (AG) made a remark as follows:

Nigeria is not a nation. It is a mere geographical expression. There are no “Nigerians” in the sense as there are “English”, “Welsh”, or “French”. The word “Nigeria” is merely a distinctive appellation to distinguish those who live within the boundaries of Nigeria from those who do not.

Similarly, in 1948, Sir Abubakar Tafawa Balewa, a leader of the Northern Peoples’ Congress (NPC), affirmed in the Legislative Council that:

Since 1914 the British Government has been trying to make Nigeria into one country, but the Nigerian people themselves are historically different in their backgrounds, in their religious beliefs and customs and do not show themselves any sign of willingness to unite... Nigerian unity is only a British intention for the country.

The foregoing statements are indications that, Nigeria was territorially created by the British, and within it is a conglomerate of numerous ethnic groups that is devoid of any organic unity.

Similar to the indirect rule system that the British colonial administration employed to govern Nigeria was the tri-regional colonial federalism (Osaghae, 2003). This system not only complimented the indirect rule system but also secured autonomy for the three dominant ethnic groups thereby compounded the north-south dichotomy. The implication of the colonial tri-regional federalism political system of administration for post colonial Nigeria are that, it did not only encouraged separate development of all the constituent ethnic units in Nigeria, but it also encouraged and heightened ethnopolitical conflicts between the major ethnic groups on one side, and between the major ethnic groups and the minority ethnic groups in their respective regions. From the foregoing, it is been considered that, the construction of tri-regional colonial federalism marked one of the beginnings from when the various ethnic groupings in Nigeria started to consider one another from the perspective of “others and us” in the

scheme of things (Osaghae, 2001). Furthermore, it has also been reasoned that the adoption and use of the colonial tri-regional federalism, and thus the eventual emergent and categorization of northerners and southerners, or the north- south dichotomy is one of the issues that have plagued Nigeria up to the present time (Oтите, 2000).

As Nigeria approached political independence, the tri-regional colonial federal structure manifested itself in the form of the emergence of regional/ethnic based political parties, for example, the Northern people's Congress (NPC) in the north, the Action Group (AG) in the west, and the National Council of the Nigerian Citizens (NCNC) in the east (Babawale, 2003). The point being made here is that, during the early periods of the struggle for independence, the nationalists tried to create a common Nigerian Identity by recruiting people from various ethnic backgrounds in the country into the anti-colonial struggle. The overriding goal of Nigeria's political elites was how to create a feeling of common belonging among Nigeria's diverse ethnic groups. But at the same time, as Nigeria advanced towards independence, there were latent fears of political and economic domination. Given the latent fears among the ethnic groups, Nigeria started to witness a major regionalization of Nigerian Nationalism (Coleman, 1986). Immediately political independence was granted on 1st October 1960 and the spoils of the victory were to be shared, there was crass competition for the occupation of public bureaucracies left behind by the colonial masters. In order for the elites to win occupation of public offices, ethnic ideological tendencies were invoked by the political elites. It is on the basis of the foregoing Njoku (1999:8) observed that, 'the exit of the British colonial masters paved the way for the emergence of internal colonizers who relied on tribalistic ideologies and oppressive regional power for their constituent interest...'

The period starting from 1st October, 1960-1966, that is, Nigeria's first republic can be said to be the era when Nigeria started to witness transformation of latent fears into actual ethnopolitical crises. This is because; the fear of domination and the need to remove the fear resulted in sequences of ethnopolitical conflicts between 1962 and 1966, and reoccurrence of several others from the 1990s to date. For instance, in 1962/63, there was the census crisis, in 1964; there was the Western Nigeria regional crisis, in 1965, there was the Federal election crisis. Nigeria's political scene remained tensed until the first military coup was carried out on January 15, 1966. Majority of its

principal movers were Igbo officers, led by Major Kaduna Chukwuma Nzeogwu. Once, the coup was perceived as having an ethno-regional dimension, and as exempting leading politicians and military officers of Igbo extraction from physical elimination, the interpretation of the scenario as sectarian and sectional surfaced. Among those killed were the Prime Minister of Nigeria, Sir Abubakar Tafawa Balewa, The Premier of Northern Region, Sir Ahmadu Bello, the Premier of Western Region, Chief Ladoke Akintola, and the Federal Minister of Finance, Chief Okotie-Eboh (a mid-Westerner). Nnoli (1995:242) depicts how the apparently sectional killings extended to the military where 'four out of the five northern officers of the ranks of Lt. Colonel and above were killed, two of five from the West, none out of seven from the East and one out of the four from Midwest'. Subsequently, the coup leaders were rounded up and thrown into detention without trial. Regional and national power was taken over by top military officers led by Major General Aguiyi Ironsi, who was an Igbo. What followed was the formation of the Federal Military Government, the banning of political parties and political activities.

However, before the Aguiyi Ironsi led military regime could settle down, officers of Northern origin executed a counter coup on July 27, 1966. In Nigerian parlance, some analysts have labeled it as a revenge coup, because it was principally targeted at the Igbo. The military faction that came to power, with the then Lt. Colonel Yakubu Gowon as Head of State, could be described as one nurtured by the NPC and the Northern establishment (Ademoyega, 1981). There occurred a seemingly organized massacre of the Igbo in different parts of Nigeria, especially in the North, and with some reprisal killings of much less magnitude of Northerners in the East. In the process of the violent ethno-political conflict, the Military Governor of the Eastern Region, Lt. Colonel Odumegwu Ojukwu, refused to recognize the military government led by Yakubu Gowon. What escalated the ethno-political conflict to the peak was the eventual declaration of secession in the Eastern Region. For instance, in a statement made by Lt. Colonel Chukwumeka Odumegwu Ojukwu quoted by Babawale (2003:8), Ojukwu categorically declared that, 'the people of Eastern Nigeria could no longer be protected in (their) lives and in (their) property by any Government based outside Eastern Nigeria'. This statement culminated in the birth of the Republic of Biafra that was led by Ojukwu, and the eventual Nigeria-Biafra War from 1967-1970. The Nigeria-Biafra war eventually came to an end with the surrender

of Biafra in 1970. At the end of the war, the then Head of State, General Yakubu Gowon declared in an address to the nation that there was 'no victor nor vanquish' in the just executed war of attrition with the Igbos. Despite this symbolic statement, the memory of the war is far from over and is still dangling over Nigeria.

As in many countries on the African continent, of the fifty years of Nigeria's political independence, it experienced protracted military rule of approximately thirty five years. During these periods, Nigeria experienced centralization of governance. This mode of centralization of power was akin to the military command structure, by which instructions and orders are enforced only from top to bottom. The point being made here is that, of the thirty five years of various military regimes in Nigeria, the Northernist tendency, with roots in the July 27, 1966 counter-coup, remained dominant in all the different military regimes that have ruled Nigeria. Worthy of note is that, the re-incarnated forces of the Northern Peoples Congress (NPC), but this time around with a national spread and re-alignments all over Nigeria became the National Party of Nigeria (NPN), which administered the country during the second republic from October 1, 1979 to December 31, 1983.

From the early 1980s, the economic crisis had begun to set in and the military exploited the situation to justify the overthrow of the civilian administration of Alhaji Shehu Aliyu Shagari on December 31, 1983. From 1983-1999, Nigeria registered all manners of military regimes that included, General Muhamadu Buhari, General Ibrahim Babangida, Late General Sani Abacha and General Abdulsalami Abubakar. Characteristically, politics of state building of the authoritarian military juntas was rulership with massive repression and suppression, accumulation of wealth and plundering the country in the most personalized fashion. In response to military dictatorship, pro-democracy movements started to operate underground. This was when pro-democracy bodies such as the Socialist Congress of Nigeria (SCON), National Consultative Forum (NCF) and later the Committee for the Defense of Human Rights (CDHR) emerged. These bodies in collaboration with others attempted to hold a mock Sovereign National Conference in 1989, but the military government aborted it. Increasingly, the agitation for the Sovereign National Conference was derailed, as it slipped from the control of its initiators completely as ethnicists and their militia organs gave the SNC a new definition. New forces entered the battlefield when the military rulers dragged Nigeria into further murky waters of ethnic politics

and regionalism, by the annulment of the presumed victory of M.K.O Abiola in the 1993 presidential election. The immediate reaction to the annulment of the June, 12, 1993 election was its interpretation in ethnic terms in many quarters as the determination of the North to deny a Southerner from becoming the president of the Federal Republic of Nigeria.

Nowhere in the country did the Nigerian military regimes carry out oppression and oppression in the name of the so called politics of state building than in the Niger Delta. Years of exploitation of oil resources derived from the region from which Nigeria earns over 90 percent of its export revenue coupled with the general neglect of the social facilities, employment, lack of industries and infrastructure and the destruction of the environment, state repression in the communities led to serious agitation and protests (Bassey, 2000). The Military government unleashed violent repression on its citizens and the local communities, including women and children. The military government also embarked on blackmail campaigns against the local elites that were championing the community rights and struggling for the environmental protection by portraying their struggles as attempts in the direction of succession. A culminating point was reached on November 10, 1995 when Ken Saro-Wiwa, the leader of the Movement for the Survival of Ogoni People (MOSOP), and eight other Ogoni activists were executed.

At another related level, the military regime unofficially employed some measures bordering on state terrorism to carry out its wishes. Secret squads were set up to physically annihilate opponents of the regime. Pro-democracy activists, journalists, and patriots were hunted and thrown into detention or killed. The very prominent cases were the brutal killing of Kudirat Abiola (wife of M.K.O Abiola) and Alfred Rewane a financier of the opposition National Democratic Coalition (NADECO). There was also the case of physical elimination of a journalist, Bagauda Kalto, who was kidnapped and subsequent bombed to death in a hotel in Kaduna. The military rulers often resorted to the use of armoured tanks to mow down the Nigerian citizens that were out for peaceful pro-democracy protests, especially in the southwest, which was the main zone of opposition after the annulled June 12, 1993 elections. Indeed, this was an era in which public governance was transformed into a question of unlimited power without responsibility, and the late General Sani Abacha was particularly noted for this.

The various military regimes in Nigeria were also deeply involved in the politicization of religion. The dictators approached and went into all sorts of Christian and Muslim circles to look for legitimacy even at the expense of undermining national unity. Deeper grounds were dug in the Nigerian society for religious hostilities, animosities and hatred. The military regimes played dangerous games with a highly emotive issue with the potential to set the country in flames. Beyond this was the increased destruction of relations between people of different faiths in a multi-religious society in which the military dictators were using labels and symbols, and mobilizing religious groupings for support and extending state resources to them (Ibrahim, 1991).

As indicated above, for many years Nigerians and pro-democracy organizations waged relentless struggle against military authoritarianism. Another side of the matter was that the military was consuming itself due to internal contradictions, which included coups and framed up coups. A landmark was the physical elimination of real and imagined opponents of the junta. The sudden death of General Sani Abacha on June 8, 1998 provided an opportunity for the military to save itself from itself. The whole process for the transfer of power was a guided one and did not involve the people. However, no matter the limitations, the process of transition to civilian administration was a relative victory for the people and organizations that struggled against military authoritarianism and somehow provided opportunity to make fresh start.

3. Summary and Conclusion

This paper started by examining the process and methods of the colonial administration, and noted that, to a large extent, the colonial phase laid the foundation for ethno-political relations in postcolonial Nigeria. This is most especially that its policies of indirect rule and tri-colonial federalism encouraged differential development of the various parts of Nigeria. The paper also examined how the Pan-Nigerian nationalists forged a united front in their struggle to achieve independence by denouncing ethnicity and regionalism. But since October 1st, 1960 when Nigeria attained political independence, its unity in diversity has been challenged by growing ethno-political conflicts at the highest level. The paper specifically examined post

independence state building efforts of successive civilian administration and military regimes from 1960 to 2010.

Implicit in the argument of this paper is that, the major factors that are central to the growing ethnopolitical conflicts in post independence Nigeria includes among others: First, the prevalence of mutual fear and suspicion of political and economic domination. The mutual fear and suspicion have thus made state power the object of struggle. The ultimate need to struggle for or clinging to state power is based on the notion that, with state power, ethnic identity and material well being of the ethnic groups in power is secure. Secondly, the prolong decades of military presence that extended its kind of command structure to the arena of governance. The various military regimes was based and nurtured on repression. Smothering ethnic, regional and religious tensions in Nigeria have often been fanned into full-blown conflict by the arbitrary, drastic, and heavy handed actions of the unelected authoritarian regimes. Nigerians never had opportunities for an all embracing national discourse and dialogue to enable them learn and develop democracy that will accommodate its diversity. Lastly, many Nigerian leaders since independence, both the civilian administration and military regimes and their cohorts have promulgated and executed series of unpopular and obnoxious policies. Majority of these policies had sparked ethnic resentment and agitations and which eventually encouraged the emergence and proliferation of many ethnic based organizations and militia forces into the Nigeria civil society.

4. References

- Ademoyega, A., 1981. *Why We Struck: The Story of the Nigerian Coup*. Ibadan: Evans Brothers.
- Awolowo, O., 1947. *Path to Nigerian Freedom*. London: University Press.
- Babawale, T., 2003. *Urban Violence, Ethnic Militias and the Challenge of Democratic Consolidation in Nigeria*. Lagos: Malthouse Press Ltd.
- Bassey, N., 2000. *The Niger Delta and the Future of Democracy in Nigeria*, a Paper Presented at the Conference for the Assessment of Democratic Reform in Nigeria. Lagos, January, 2000.
- Coleman, J.S., 1986. *Nigeria: Background to Nationalism*. Berkeley: University of California Press.

- Federal Republic of Nigeria., 1948. *Legislative Council Debates*, Lagos: Federal Government Printer.
- Ibrahim, J., 1991. Religious and Political Turbulence in Nigeria. *Journal of Modern African Studies*, 29 (1), pp. 421-456.
- Ikelegbe, A., 2005. State, Ethnic Militias, and Conflict in Nigeria. *Canadian Journal of African Studies*, 39 (3), pp. 479-490.
- Imobighe, A.T., 2003. Ethnicity and Ethnic Conflict in Nigeria: An Overview. In: A.T Imobighe, ed. 2003. *Civil Society and Ethnic Conflict Management in Nigeria*. Ibadan: Spectrum Books Ltd. pp. 13-36.
- Kazah-Toure, T., 2007. Nigeria: Challenges to the State and the Ways of Breaking the Quagmire. In: G. K. Kieh, ed. 2007. *Making the State Relevant in Africa*. Lanham (MD): Lexington Books, pp.151-175.
- Njoku, R.C., 1999. Consociationalism: It's Relevance for Nigeria. *Nationalism and Ethnic Politics*, 5 (2), pp. 1-35.
- Nnoli, O., 1978. *Ethnic Politics in Nigeria*. Enugu: Fourth Dimension Press.
- Osaghae, E.E., 2001. From Accommodation to Self Determination: Minority Nationalism and the Reconstruction of the Nigerian State. *Nationalism and Ethnic Politics*, 7 (1), pp. 1-20.
- Osaghae, E.E., 2003. Federalism and Ethnic Question in Africa. In: J.M. Mbaku; P.O. Agbese & M.S. Kimenyi, eds. 2003. *Ethnicity and Governance in the Third World*. Aldershot: Ashgate Publishing Company, pp. 1-33.
- Osaghae, E.E., 2003. Explaining the Changing Pattern of Ethnic Politics in Nigeria. *Nationalism and Ethnic Politics* 9 (3), pp. 54-73.
- Otite, O., 2000. *Ethnic Pluralism and Ethnic Conflicts in Nigeria*. 2nd ed. Ibadan: Shaneson Ltd.
- Uroh, C.O., 1992. On the Ethics of Ethnic Balancing in Nigeria: Federal Character Reconsidered. In: K. Amuwo, ed. 1992. *Federalism and Political Reconstructing in Nigeria*. Ibadan: Spectrum Books Ltd. pp. 189-104.

Value Destruction from Spin-offs

Nadisah Zakaria and Glen Arnold, *Salford Business School, University of Salford*

Abstract

This paper investigates the short and long-run share returns performance of Malaysian spin-off firms during the period 1980 to 2006. Using daily and monthly data, we examine the share returns performance of spin-off firms against the market benchmarks of Malaysia All-Shares Equal Weight Index (MAS-EWI) and Malaysia All-Shares Value Weight Index (MAS-VWI). We find that the parent firms significantly outperformed the market during the few days surrounding the announcement date. In contrast, the parent, spun-off and combined firms significantly underperformed the market in the three-year holding periods following the completion month of spin-offs. On average, the under-performance and over-performance of parent, spun-off and combined firms are more pronounced when they are measured against the market benchmark of Malaysia All-Shares Equal Weight Index (MAS-EWI) than the Malaysia All-Shares Value Weight Index (MAS-VWI). Overall, these findings imply that spin-offs create value in the short-run period, however destroy value in the long-run period.

Keywords:

Spin-offs, share returns performance

1. Introduction

The spin-off of firms is an area of interesting research that has received some attention by practitioners and scholars in finance. A crucial question in corporate spin-offs is whether the action creates wealth for their shareholders over the short and long-run periods. Earlier studies suggest that spin-offs generate positive abnormal returns above market average over the period surrounding the announcement. However, the long-run share returns performance of spin-off firms remains controversial. The present study is aimed to discover how Malaysian spin-off firms perform in both the long-run and the short-run relative to certain benchmarks.

This paper provides a direct comparison with similar research conducted in the US and European markets and hence makes several contributions to the existing literature in corporate spin-offs. First, we employ two market indices; Malaysia All-Shares Equal Weight Index (henceforth MAS-EWI) and Malaysia All-Shares Value Weight Index (henceforth MAS-VWI)¹¹. Both benchmarks are new and unique in Malaysian event studies. Extant event studies in Malaysia commonly adopt two popular market indices, namely FTSE Kuala Lumpur Composite Index (KLCI) and FTSE Bursa Malaysia EMAS Index¹². Second, we use Cumulative Abnormal Returns (CARs), Buy-and-Hold Abnormal Returns (BHARs) and Market Model as the abnormal return metrics to calculate both short and long-run share returns performance based on the event-time approach whereas previous studies used only one of these models in their analysis. Third, we use an equal weighting procedure, rather than value weighting in calculating portfolio returns. As noted by Loughran and Ritter (2000), equal weighting produces point estimates that are relevant from the point of view of a manager, investor and researcher in attempting to predict the abnormal returns. Fourth, as there is no long-run evidence documented in the Malaysia capital market, the present study adds to a growing body of international evidence on the long-run performance of spin-offs event.

In a corporate spin-off, the shares of a subsidiary are distributed on a pro-rata basis (or at least 80% of the spun-off units' shares) to the original shareholders of the parent firms. Following the transaction, the subsidiary becomes a totally independent firm, as a newly spun-off firm; therefore parent firms have no continuing relationship with it. The former parent shareholders, however own two different securities; the shares from the parent and the shares from the newly spun-off firm.

Pure voluntary spin-off activity by Malaysian listed firms began in the late 1980s in tandem with the development of capital market. Nevertheless, this event has gathered momentum beginning in the 1990s. It is of interest to note that major increases of the corporate spin-offs decision are undertaken during the bull-run period of 1993 to 1994; and also in the subsequent years following the 1997 crisis. Evidently, out of 35

¹¹ Both benchmarks cover all size of all firms (small firms and large firms based on the market capitalization) within the market and hence provide investors with a better tool to benchmark their investments.

¹² Both benchmarks comprise of different components of firms based on the market capitalization. The FTSE Bursa Malaysia KLCI Index consists of 30 largest firms in the market, whilst the FTSE Bursa Malaysia EMAS Index constitutes the top 100 largest firms and the 223 small capitalization firms.

cases, 66% of the spin-off announcements occurred during the recovery year of 1999. Through a case-by-case review from the financial press announcements and relevant supporting documents, for example individual firm annual report from year 1980 to 2006, the spin-off event in Malaysia is said by managers to be mostly motivated by increased in efficiency gain. Though limited evidence, other motivating factors are said to be to facilitate a merger or takeover; and to transfer a debt burden from parent to newly spun-off firms. By looking at the performance of shares we may find some evidence supporting the claim of greater efficiency or greater shareholder return through mergers or debt shifting. Thus, addressing the share returns performance of the spin-off firms in Malaysia capital market is of interest and importance.

We study a sample of 35 purely voluntary spin-offs completed between 1980 and 2006. In a previous study, using 85 Malaysian spin-off firms, Yoon and Ariff (2007) find significant positive cumulative average abnormal return (CAAR) of +22.7% in a two-day (-1,0) event window surrounding the announcement date during the period of 1986 to 2003. However, they do not study long-run share returns performance. Therefore the present study represents the first comprehensive study of corporate spin-offs in Malaysia capital market as we attempt to investigate the share returns performance of parent, spun-off and combined firms in the short and long-run period against the MAS-EWI and MAS-VWI.

Our study concludes that: (1) there is significant *over*performance (up to +5.72% above the market) in the short-run period surrounding the spin-offs announcement day (day -1 through day +1) for parent firms; (2) there is significant *under*performance (up to -58.71% below the market) in the long-run period for parent firms in the three-year holding periods following the completion month of spin-offs; (3) there is significant *under*performance (up to -44.07% below the market) in the three-year period for spun-off firms following the month of their listing; (4) there is significant *under*performance (up to -60.42% below the market) for combined firms in the three-year holding periods following the completion month of spin-offs. Overall, these findings imply that spin-offs create value in the short-run period, however destroy value in the long-run period.

The remainder of the paper is organized as follows. Section 2 describes a brief literature review concerning the short and long-run share returns performance of spin-off firms. Section 3 explains on the sample selection, data and methodology. Section 4

presents the results for both short and long-run share returns performance of Malaysian spin-offs. Section 5 concludes the paper.

2. Literature review

A strong spin-off effect has been shown in the US and European studies (e.g., Hite and Owers, 1983; Schipper and Smith, 1983; Miles and Rosenfeld, 1983; Rosenfeld, 1984; Cusatis et al., 1993; Desai and Jain, 1999; Krishnaswami and Subramaniam, 1999; Veld-Veld Mekuovela, 2001; Kirchmaier, 2003). In general, the evidence shows that investors who purchase shares surrounding the spin-offs announcement window (short-run) and in the three years holding periods following the completion of spin-offs (long-run period) gain high positive returns. However, the evidence of long-run post spin-offs performance is far from consistent, with some researchers reporting negative results. The US studies (e.g., Cusatis et al., 1993; Desai and Jain, 1999) consistently demonstrate net value creation to the shareholders. In the long-run, but the European studies (e.g., Veld-Veld Merkuovela, 2001; Kirchmaier, 2003) conclude that spin-offs do not create value to the shareholders in the long-run.

Using 146 voluntary US spin-off firms over the 1965-1988 periods, Cusatis et al., (1993) investigate value creation through spin-offs by measuring the share returns performance of parent, spun-off, and combined firms for a period up to three years following the spin-offs. The share returns performance of these firms is analyzed using the buy and hold investment strategy against the benchmark of matched-firms portfolios (adjusted to the size and industry). They report significantly positive abnormal returns for spun-offs, their parents and combined firms in the three years holding periods following the spin-offs.

Similar to Cusatis et al., (1993), Desai and Jain (1999) compute the buy-and-hold abnormal returns of 155 US firms using a matching firm methodology in the three-year formation period. They show results of combined, spun-off and parent firms separately for focus-increasing¹³ and non focus-increasing sub-samples. Consistent with Cusatis et al., (1993), they find evidence of outperformance for both combined and spun-off firms relative to their matching firms in the three-year holding period

¹³ A spin-off is considered to be a focus-increasing when the standard industrial classification (SIC) code of the subsidiary is different from its parent.

following the completion of the spin-offs. The average buy-and-hold abnormal returns in the three-year holding period are positively significant, +19.82% and +32.31% for combined and spun-off firms, respectively. However, for parent firms, the result shows a positive but insignificant abnormal return of +15.18% in the three-year holding period.

Veld and Veld-Merkuovela (2001) investigate the short and long-run wealth effect of 161 spin-off announcements by European firms over the period from January 1987 to September 2000. During these years, most spin-offs occurred in the United Kingdom (70), followed by Sweden (24), Germany (14) and Italy (11). The study indicates that for all countries, the cumulative average abnormal return, CAAR is +2.35% over the event window (day -1 through day +1), positively significant at 1% level. Using the Cumulative Abnormal Returns (CARs) Model, the authors declare, after examining the share returns performance in the three-year holding periods following the completion of spin-offs that all parent, spun-off and combined firms insignificantly underperform the market. Veld and Veld-Merkuovela (2001, pp. 25) conclude that, “spin-offs really create value on the short-run but not in the long-run”.

Kirchamaier (2003) investigates the short and long-run effects of the spin-off event on shareholder wealth using a sample of 48 European firms. Following a similar approach to Veld and Veld-Merkuovela (2001) in determining the abnormal returns, they find positively significant announcement effects of +5.4% during the three-day event period (-1,+1), respectively. The combined performance of both parent and spun-off firms results a statistically insignificant abnormal return of +4.2% from day +0 to day +699, whereby on average both firms outperform the market. In a comparison between spun-off and parent firms during the post event, spun-off firms appear to outperform the market whereas parent firms don't; spun-off firms demonstrate a statistically significant of +17.3%. The parent firms insignificantly underperform the market by -5.9%.

For the Malaysian market, Yoon and Ariff (2007) conduct a study in corporate spin-offs over the short-run period following the spin-offs announcement. No evidence of long-run share returns performance is recorded in their study. Both authors adopt three different models to estimate the daily abnormal returns. They investigate the short-run announcement effect over the event window from day -100 through day +50 for the parent firms; and the performance of spun-off firms following their listing date (day 0 through day +50) against the FTSE Bursa Malaysia Kuala Lumpur Composite

Index or FTSE KLCI and control firms. However, the disadvantage of FTSE KLCI is it does not include the cohort of small size firms.

Over the two-day event window (-1,0), the study demonstrates a positively significant abnormal return of +22.7% above the market average, hence increase the shareholder value. Surprisingly, the result obtained is far higher than those in the US, Europe, and Asia Pacific markets. On average, less than +8% of significant abnormal returns were reported in these markets. The authors find statistically significant abnormal return in the pre-event window (day -50 to day 0); possibly because of information leakage; and insignificant result in the post-event window (day +1 to day +50) for parent firms. For spun-off firms, the study suggests that there is 50% increase in value to the original shareholders of the spun-off firms from the date of listing up to +50 trading days. The authors claim that any observed increase in the share prices of spun-off firms following the listing date arises from the market re-valuation of the spun-off firms by the subsequent purchaser of the shares after the listing.

3. Data selection and methodology

To ensure a comprehensive study is conducted, a population of spin-offs involving firms quoted on the Bursa Malaysia is generated. Hence, both parent and spun-off firms traded on the Main Board, the Second Board and MESDAQ of Bursa Malaysia from 1st January 1980 to 31st December 2006 are identified. The identities of both parent and spun-off firms are obtained from the Investors Digest and Bursa Malaysia's website. In the present study, daily data is used to identify abnormal returns above the market average for short-run announcement effect, whilst monthly data is employed to measure the long-run share returns performance following the completion month of spin-offs. The combined firms are created by weighting the return of parent and that of the spun-off firms by the market value of equity at the end of the month of the spin-offs completion date (Desai and Jain, 1997).

In the case of daily data, defining $t=0$ as the announcement date, $t=-20$ days to $t=+20$ days represents the event period or observation period, and $t=-220$ days to $t=-21$ constitutes the estimation period. This estimation period is crucial to apply in the Market Model for obtaining the value of alpha, α and beta, β . On the other hand, using monthly data the event period ranges from 0 month to +36 months, while the estimation period covers a period between -60 months to -11 months. With these

defined timelines, the daily and monthly closing share price data (adjusted to dividend) for each parent and spun-off firm, and market indices are collected from the Datastream database. The present study employs two market indices; the MAS-EWI and MAS-VWI to compute the daily and monthly market returns.

To evaluate the share returns performance of parent, spun-off and combined firms, the present study employs the event-time approach that comprises of (a) Market Model (MM); (b) Cumulative Abnormal Returns (CARs) and (c) Buy-and-Hold Abnormal Returns (BHARs) Model. We adopt equal weighted portfolio returns because spin-offs event is a random event that occurs intermittently from year 1980 to 2006. According to Loughran and Ritter (2000, pp.363, note 2), “if one is trying to measure the abnormal returns on the average firms undergoing some event, then each firm should be weighted equally.... [this] will produce point estimates that are relevant from the point of view of a manager, investor, or researcher attempting to predict the abnormal returns associated with a random event”.

4. Results

The following tables report evidence of the percentage daily and monthly abnormal returns (adjusted to the market) on the parent, spun-off and combined firms against the Malaysia All-Shares Equal Weight Index (MAS-EWI) and Malaysia All-Shares Value Weight Index (MAS-VWI). Each table exhibits separate estimates of abnormal returns using Cumulative Abnormal Returns Model (CARs), Market Model (MM) and Buy and Hold Abnormal Returns (BHARs). The first two methods define abnormal returns as cumulative average abnormal returns (CAARs), whilst the latter method defines abnormal returns as average buy and hold abnormal returns (ABHARs). The t-statistics are calculated to test the significant of the results. 0 denotes the announcement date of the spin-off event. Asterisks indicate statistical significance at the 10% (*), 5% (**) and 1% (***) level.

a) Short-run performance of parent firms following the spin-offs announcement

Table 1: Announcement period: share returns performance of the parent firms over a short-run adjusted for MAS-EWI

Interval (day)	CARs Model			Market Model			BHARs		
	CAARs		T-STAT	CAARs		T-STAT	ABHARs		T-STAT
(-1,+1)	5.02%	**	2.64	5.11%	***	2.98	5.17%	***	4.06
0	2.17%	***	3.25	2.20%	***	3.28	2.17%	***	3.00
(0,+1)	4.60%	***	17.74	4.55%	***	30.62	4.71%	***	4.29

Table 2: Announcement period: share returns performance of the parent firms over a short-run adjusted for MAS-VWI

Interval (day)	CARs Model			Market Model			BHARs		
	CAARs		T-STAT	CAARs		T-STAT	ABHARs		T-STAT
(-1,0)	2.81%		1.53	2.81%		1.67	2.83%	***	3.29
(-1,+1)	5.55%	**	2.67	5.34%	***	2.90	5.72%	***	4.64
0	2.32%	***	3.31	2.25%	***	3.33	2.32%	***	3.38

Prior to the spin-off announcement, the average buy and hold abnormal returns (henceforth ABHARs) documented in the MAS-VWI are larger and stronger (positively significant) in magnitude relative to the ABHARs documented in the MAS-EWI (Table 1)¹⁴ Though the CARs and the Market models exhibit insignificant results over this period; the cumulative average abnormal returns (henceforth CAARs) are persistently positive for both market benchmarks. Over the periods near to spin-off announcement (day -1 to day 0), only the BHARs Model documents positively significant ABHARs of +2.60% and +2.83% for both MAS-EWI and MAS-VWI, respectively.

The positive significant abnormal returns over two-day event window (-1,0) are comparable with the US results in Schipper and Smith (1983). Surprisingly, the results show stronger significant positive abnormal returns compared with the European spin-offs parent firms (e.g. Veld and Veld Merkuovela, 2001). Market

¹⁴ As a robustness check, we compute the statistical significance level using the standard deviation (employed in the t-statistics' calculation) based on the pre-event estimation period. For daily data, the pre-event estimation period is estimated from day -220 to day -21 and from month -60 to month -11. The results show significant improvements in the significance level for all event windows (particularly when using the CARs Model and Market Model). However, we do not report them in the present paper.

inefficiencies (due to information leakage) might be the possible cause for the positive abnormal returns witnessed prior to the spin-off announcement.

Over the periods surrounding the spin-offs announcement, all the abnormal return metrics, on average, demonstrate positively significant abnormal returns against the MAS-EWI and MAS-VWI benchmarks. Using the MAS-EWI as a benchmark, spin-offs generate positively significant CAARs and ABHAR of +5.02%, +5.11% and +5.07% for the CARs, MM and BHARs model, respectively in the three-day event window (-1,+1). The abnormal returns are more pronounced when they are measured against the MAS-VWI. Within the same event window, the CAARs and the BHARs are recorded at +5.55%, +5.34%, +5.72% for the CARs, MM and BHARs models, respectively.

b) Long-run performance of parent firms following the listing of spun-off firms

Table 3: Long run performance: share returns performance of the parent firms adjusted for MAS-EWI

Interval (month)	Market Adjusted Model			Market Model			BHARs		
	CAARs		T-STAT	CAARs		T-STA'	ABHARs		T-STA'
EX+1 TO EX+12	-28.44%	***	-4.24	-23.50%	***	-3.73	-15.92%		-1.64
EX+1 TO EX+24	-46.11%	***	-4.62	-35.27%	***	-3.50	-35.50%	***	-5.41
EX+1 TO EX+36	-58.31%	***	-5.09	-37.73%	***	-3.25	-48.79%	***	-4.81

Table 4: Long run performance: share returns performance of the parent firms adjusted for MAS-VWI

Interval (month)	Market Adjusted Model			Market Model			BHARs		
	CAARs		T-STAT	CAARs		T-STAT	ABHARs		T-STAT
EX+1 TO EX+12	-24.93%	***	-3.38	-26.17%	***	-3.51	-12.73%		-1.25
EX+1 TO EX+24	-32.27%	***	-2.88	-35.94%	***	-3.16	-19.49%	**	-2.56
EX+1 TO EX+36	-36.14%	**	-2.64	-39.45%	***	-2.99	-27.18%	***	-2.94

All the abnormal return metrics suggest that parent firms underperform the MAS-EWI and MAS-VWI benchmarks pursuant the listing of spun-off firms over the three-year

holding period. Using the MAS-EWI benchmark, both the CARs Model and the BHARs Model demonstrate negatively significant CAARs and ABHARs of -58.31% and -48.79%, respectively. Though the abnormal return is negatively significant, the MM shows better performance of parent firms, with the CAAR of -37.73%. Similarly, using the MAS-VWI the entire abnormal return metrics document negatively significant CAARs and ABHARs over the holding period of three years. The CAARs and ABHAR of -36.14%, -39.45% and -27.18% are presented in the CARs Model, MM and BHARs Model, respectively. Therefore it can be concluded that the long-run share returns performance of parents worsen following the spin-offs decision.

c) Long-run performance of spun-off firms following the listing of spun-off firms

Table 5: Long run performance: share returns performance of the spun-off firms adjusted for MAS-EWI

Interval (month)	Market Adjusted Model			Market Model			BHARs	
	CAARs	T-STAT		CAARs	T-STAT	ABHARs	T-STAT	
EX+1 TO EX+12	18.83%	***	-4.26	-14.77%	**	-2.59	-12.04%	-1.44
EX+1 TO EX+24	26.53%	***	-2.74	-16.07%		-1.43	-17.01%	-1.43
EX+1 TO EX+36	43.03%	***	-4.00	-23.17%	*	-1.90	-44.07%	*** -4.07

Table 6: Long run performance: share returns performance of the spun-off firms adjusted for MAS-VWI

Interval (month)	Market Adjusted Model			Market Model			BHARs	
	CAARs	T-STAT		CAARs	T-STAT	ABHARs	T-STAT	
EX+1 TO EX+12	-15.69%	***	-3.10	-16.92%	***	-3.28	-9.00%	*** -0.98
EX+1 TO EX+24	-12.04%		-1.09	-15.66%		-1.40	-0.89%	-0.07
EX+1 TO EX+36	-21.86%	*	-1.76	-25.32%	**	-2.07	-23.28%	-2.20

All the abnormal return metrics for spun-off firms underperform their benchmarks in the three-year holding periods following the completion month of spin-offs. Using the MAS-EWI benchmark, the CAARs for both MM and CARs Model are -43.03% and -23.17%, respectively. Both abnormal returns are negatively significant at 1% and 10% levels. Similarly, the BHARs records negatively significant ABHAR of -44.07%.

When the abnormal return metrics are measured against the MAS-VWI, although all the abnormal returns demonstrate negatively significant results, the performance of spun-off firms, however is slightly better than those in the MAS-EWI. The CAARs for both CARs Model and MM are -21.86% and -25.32%, respectively. The ABHAR for the BHARs Model however, exhibit negatively insignificant result of -23.28%.

The findings imply that the spun-off firms demonstrate a strong negative performance following the spin-offs decision. However, the long-run share returns performance of the spun-off firms is better than the parent firms. The possible explanation is that the spun-off firms are smaller in size and are more focused than their corresponding parent firms.

d) Long-run performance of combined firms following the listing of spun-off firms

Table 7: Long run performance: share returns performance of the combined firms adjusted for MAS-EWI

Interval (month)	Market Adjusted Model			Market Model			BHARs		
	CAARs	***	T-STAT	CAARs	***	T-STAT	ABHARs	T-STAT	
EX+1 TO EX+12	-27.66%	***	-4.40	-22.81%	***	-3.86	-18.01%	**	-2.22
EX+1 TO EX+24	-44.13%	***	-4.88	-33.29%	***	-3.59	-36.35%	***	-5.93
EX+1 TO EX+36	-60.42%	***	-5.95	-39.82%	***	-3.90	-51.27%	***	-5.27

Table 8: Long run performance: share returns performance of the combined firms adjusted for MAS-VWI

Interval (month)	Market Adjusted Model			Market Model			BHARs		
	CAARs	***	T-STAT	CAARs	***	T-STAT	ABHARs	T-STAT	
EX+1 TO EX+12	-24.34%	***	-3.73	-25.57%	***	-3.96	-14.83%	*	-1.71
EX+1 TO EX+24	-30.11%	***	-3.00	-33.76%	***	-3.31	-20.34%	***	-2.82
EX+1 TO EX+36	-38.24%	***	-3.13	-41.63%	***	-3.59	-29.68%	***	-3.34

Overall, the evidence suggests that the combined firms underperform both benchmarks, MAS-EWI and MAS-VWI pursuant to the completion month of spin-offs. When the abnormal returns are measured against the MAS-EWI, there are

negatively significant CAARs and ABHAR of -38.24%, -41.63% and -28.68% for the CARs, MM and BHARs models in the three-year holding period. Similarly, negatively significant abnormal returns of -38.24%, -41.63% and -29.68% are demonstrated over the same event window when the CAARs and ABHAR are measured against the MAS-VWI.

Therefore, it can be concluded that the long-run share returns performance of proforma combined firms worsen following the spin-offs.

5. Summary and conclusion

The present study demonstrates a number of new findings about Malaysia corporate spin-offs. First, the presence of strongly significant positive abnormal returns for parent firms over a three-day event window (-1,+1) up to +5.72% is of considerable interest. On average, the over-performance of parent firms are more pronounced when they are measured against the MAS-EWI benchmark. Although the findings are slightly greater than those documented in the US studies (Desai and Jain, 1999), they are comparable to several European studies (Veld and Veld-Merkuovela, 2001; Kirchmaier, 2003).

Second, all the abnormal return metrics suggest that parent firms underperform the MAS-EWI and MAS-VWI benchmarks up to -58.71%, over holding periods of three years. The long-run underperformance of parent firms worsens following the spin-offs decision, particularly when the abnormal return metrics are measured against the MAS-EWI. These results are consistent with the European studies (Veld and Veld Merkuovela, 2001 and Kirchmaier, 2003), but substantially differ from those in the US studies (Cusatis et al., 1993; Desai and Jain, 1999).

Third, all the abnormal return metrics for spun-off firms underperform their benchmarks, both MAS-EWI and MAS-VWI for the three-year holding periods following the completion month of spin-offs up to -44.07%. Similar to parent firms, the performance of spun-off firms worsen when they are measured against the MAS-EWI. However, the long-run share returns performance of the spun-off firms is better than the parent firms. A possible explanation is that the spun-off firms are smaller in size and are more focused than their corresponding parent firms. The negatively significant long-run share returns performance of spun-off firms is contrary to the

findings documented in both European (Kirchmaier, 2003) and US (Cusatis et al., 1993 and Desai and Jain, 1999) markets.

Fourth, the results suggest that combined firms underperform both benchmarks, MAS-EWI and MAS-VWI pursuant to the completion month of spin-offs. Evidently, there are negatively significant abnormal returns up to -60.42% over the thirty-six months holding periods. Relative to the spun-off and parent firms, the underperformance of combined firms is substantially higher and worsen when they are measured against the MAS-EWI. The results are inconsistent with the US and European findings on the effect of corporate spin-off over the holding periods up to three years following the completion of spin-offs.

Overall, it implies that spin-offs create value in the short-run period however destroy value in the long-run period. Following these findings, an interesting question is “*What does this finding say about the efficiency of the stock market in pricing the share?*”

By looking at the statistical relationships, there are abnormal returns opportunities that can be exploited by investors for making abnormal returns on shares and provide evidence against the “believer” of the efficient stock market. Arnold (2008, pp.563) states that ‘in an efficient market, no trader will be presented with an opportunity for making return on a share, that is greater than a fair return for the associated with that share, except by chance’.

6. References

Bursa Malaysia, available on the internet at <http://www.bursamalaysia.com>.

Cusatis et al., (1993). Restructuring through spin-offs: The stock market evidence. *Journal of Financial Economics*, 33 (3), pp. 293-311.

Desai, H. and Jain, P. C., (1999). Firm performance and focus: Long run stock market performance following spin-offs. *Journal of Financial Economics*, 54, pp. 75-101.

Hite, G. K. and Owers, J. E., (1983). Security price reaction around corporate spin-off announcements. *Journal of Financial Economics*, 12, pp. 409-436.

Kirchmaier, T., (2003). The performance effects of European demergers. Working paper, London School of Economics, United Kingdom.

- Krishnaswami, S. and Subramaniam, V., (1999). Information asymmetry, valuation, and the corporate spin-off decision. *Journal of Financial Economics*, pp.73-112.
- Loughran, T., and Ritter, J. R., (2000). Uniformly least powerful tests of market efficiency. *Journal of Financial Economics*, 55, pp. 361-389.
- Miles, J., A. and Rosenfeld, J. D.,(1983). The effect of voluntary spin-off announcements on shareholder wealth. *The Journal of Finance*, 38 (5), pp. 1597-1606.
- Ritter, J., (1991). The long-run performance of initial public offerings. *Journal of Finance*, 46, pp. 3-28.
- Rosenfeld, J. D., (1984). Additional evidence on the relation between divestiture announcement and shareholder wealth. *Journal of Finance*, 39, pp.1437-1447.
- Schipper, K. and Smith, A., (1983). Effects of re-contracting on shareholder wealth: The case of voluntary spin-offs. *Journal of Financial Economics*, 12 (4), pp. 437-467.
- Veld, C. and Veld-Merkoulova, Y. V., (2001). Do divestiture create value? The case for European spin-off. *Journal of Banking and Finance*, 28, p. 1111-1135.
- Yoon, C. S. and Ariff, M., (2007). Corporate spin-offs, their price reactions and determinants in Malaysia. *International Journal of Banking and Finance*, 5, pp. 83-112.

