



Centre for Digital Business

**The Use of Online Shopping Acceptance Model  
(OSAM): influence of social media in Saudi  
Arabia**

**A Thesis Submitted in Fulfillment of the Requirements for the Degree  
of Doctor of Philosophy in The University of Salford**

Supervisor:

**Dr. Aleksej Heinze**

Co-supervisor:

**Dr. Agata Maccarrone-Eaglen**

Written by PhD Student

**ABER WAZZAN**

# Abstract

E-commerce in general, and online shopping in particular, are becoming popular ways of utilizing the Internet throughout the world. Social media is also becoming a widespread tool, not only for interaction with others but also for marketing. Despite this trend, there is a dearth of knowledge about the acceptance of online shopping and the use of social media in developing countries such as Saudi Arabia. Technology adoption levels in Saudi Arabia are growing rapidly but have yet to reach their full potential. One of the leading theories explaining online shopping behaviour – the online shopping acceptance model (OSAM) – has not been employed in previous studies of social media use or in developing countries such as Saudi Arabia to understand online shopping.

To address this research problem, the researcher implemented a study using a positivist approach. Quantitative data was gathered using an online survey. This survey was conducted with Saudi residents who engage with online shopping. A data set of 423 completed survey responses is used in this thesis for statistical analysis. The data was collected using a random sample and was collected from January to September 2015. The structural equation modelling tested the hypothesised relationships between the constructs as postulated in the model. Nineteen of the hypothesised links were supported and ten were rejected. Eventually, the model that has statistical and explanatory power was confirmed.

The findings indicate a positive relationship between online shopping intention and other factors of online shopping acceptance in Saudi Arabia. A positive relationship is also seen between online shopping orientation and online shopping experience. The case examines the relationship between online shopping orientation and online shopping motivation. The same applies for the relationship between online shopping and social media through the mediation of online shopping intention.

This research contributes to understanding the role of social media in OSAM in Saudi Arabia as a developing country, as OSAM incorporates social media as a new factor that influences acceptance aside from what is traditionally stipulated. A second contribution is

the finding that shopping orientation is the most important construct affecting online shopping intention in Saudi Arabia.

# **DEDICATION**

*To all my family*

*Mom, Dad, Raed, Doaa, Dalia, Braa, Anas,  
Rasha, Rami, Maha, Sedra and Sadin*

*Thank you all for helping and supporting me & I  
love all of you*

# Table of Contents

<b>ABSTRACT</b>	<b>2</b>
<b>DEFINITIONS</b>	<b>14</b>
<b>CHAPTER ONE. INTRODUCTION</b>	<b>15</b>
1.1 CHAPTER OVERVIEW	15
1.2 INTRODUCTION	15
1.3 DEFINITION OF THE PROBLEM	18
1.4 RESEARCH GAP	21
1.5 RESEARCH AIM AND OBJECTIVES	21
1.5.1 AIM	21
1.5.2 RESEARCH OBJECTIVES	22
1.5.3 RESEARCH SIGNIFICANCE	22
1.5.4 RESEARCH QUESTIONS	22
1.5.5 HYPOTHESES	23
1.6 THESIS STRUCTURE	24
<b>CHAPTER TWO. THE CONTEXT OF SAUDI ARABIA</b>	<b>26</b>
2.1 CHAPTER OVERVIEW	26
2.2 BACKGROUND	26
2.3 SAUDI ECONOMY	27
2.4 INFORMATION AND COMMUNICATION TECHNOLOGY IN KINGDOM OF SAUDI ARABIA	28
2.5 RETAIL BUSINESS IN SAUDI ARABIA	30
2.6 E-COMMERCE	31
2.7 E-MALLS IN SAUDI ARABIA	32
2.8 SOCIAL MEDIA IN SAUDI ARABIA	33
2.9 WHY STUDY ONLINE SHOPPING IN THE KINGDOM OF SAUDI ARABIA?	35
2.10 SUMMARY	35

<b>CHAPTER THREE. LITERATURE REVIEW</b>	<b>36</b>
<b>3.1 CHAPTER OVERVIEW</b>	<b>36</b>
<b>3.2 DEVELOPMENT OF THE ONLINE SHOPPING ACCEPTANCE MODEL</b>	<b>36</b>
3.2.1. THEORY OF REASONED ACTION (TRA)	36
3.2.2 THEORY OF PLANNED BEHAVIOUR (TPB)	38
3.2.3 TECHNOLOGY ACCEPTANCE MODEL	40
3.2.4 UNIFIED THEORY OF ACCEPTANCE AND USE OF TECHNOLOGY	44
<b>3.3 ONLINE SHOPPING ACCEPTANCE MODEL</b>	<b>48</b>
3.3.1 CONSUMER DEMOGRAPHICS	52
3.3.2 SHOPPING MOTIVATION	61
3.3.3 SHOPPING ORIENTATIONS	62
3.3.4 ONLINE SHOPPING INTENTION	64
3.3.5 ONLINE SHOPPING EXPERIENCE	66
3.3.6 ONLINE EXPERIENCE	67
3.3.7 NORMATIVE BELIEFS	68
3.3.8 INNOVATIVENESS	69
3.3.9 PERCEIVED OUTCOME	69
3.3.10 SATISFACTION	70
3.3.11 ATTITUDE TOWARDS	71
<b>3.4 SOCIAL MEDIA</b>	<b>72</b>
<b>3.5 WHY IS OSAM THE MOST RELEVANT FOR THIS RESEARCH?</b>	<b>75</b>
<b>3.6 LIMITATIONS OF THE ONLINE SHOPPING ACCEPTANCE MODEL</b>	<b>79</b>
<b>3.7 SUMMARY OF HYPOTHESES</b>	<b>80</b>
<b>3.8 SUMMARY</b>	<b>83</b>
<b>CHAPTER FOUR. METHODOLOGY AND RESEARCH PLAN</b>	<b>84</b>
<b>4.1 CHAPTER OVERVIEW</b>	<b>84</b>
<b>4.2 DEFINITION OF RESEARCH</b>	<b>84</b>
<b>4.3 RESEARCH PHILOSOPHY</b>	<b>85</b>
<b>4.4 RESEARCH PARADIGM</b>	<b>86</b>
4.4.1 POSITIVISM PARADIGM	86

4.4.2 INTERPRETIVISM PARADIGM	87
4.4.3 CRITICAL-SOCIAL SCIENCE PARADIGM	88
4.4.4 THE CURRENT RESEARCH	89
<b>4.5 PURPOSE OF THE CURRENT RESEARCH STUDY</b>	<b>91</b>
<b>4.6 RESEARCH APPROACH</b>	<b>93</b>
4.6.1 QUALITATIVE APPROACH	93
4.6.2 QUANTITATIVE APPROACH	94
<b>4.7 INDUCTIVE AND DEDUCTIVE APPROACHES</b>	<b>96</b>
<b>4.8 THE QUESTIONNAIRE</b>	<b>98</b>
QUESTIONNAIRE ADMINISTRATION	98
4.8.1 QUESTIONNAIRE DESIGN	100
4.8.2 LIKERT SCALE	104
<b>4.9 THE RESEARCH MODEL</b>	<b>107</b>
<b>4.10 RELIABILITY AND VALIDITY</b>	<b>107</b>
4.10.1 RELIABILITY	107
4.10.2 VALIDITY	109
4.10.3 MODEL VALIDITY AND RELIABILITY	112
<b>4.11 THE RESEARCH MODEL CONSTRUCTS</b>	<b>118</b>
4.11.1 ONLINE SHOPPING (OS)	119
4.11.2 ONLINE SHOPPING EXPERIENCE (OE)	120
4.11.3 CONSUMER DEMOGRAPHIC (CD)	120
4.11.4 SOCIAL MEDIA (SM)	122
4.11.5 SHOPPING MOTIVATION (M)	124
4.11.6 ONLINE SHOPPING INTENTION (OSI)	126
4.11.7 SHOPPING ORIENTATIONS (SO)	127
<b>4.12 SAMPLING</b>	<b>130</b>
4.12.1 SAMPLE DESIGN	131
4.12.2 SAMPLE SIZE	131
4.12.3 SAMPLING AND GENERALIZATION	136
<b>4.13 DATA TYPES</b>	<b>136</b>
<b>4.14 DATA COLLECTION</b>	<b>137</b>

<b>4.15 DATA ERROR</b>	<b>138</b>
<b>4.16 DATA ANALYSIS</b>	<b>139</b>
4.16.1 DESCRIPTIVE STATISTICS	139
4.16.2 RELIABILITY ANALYSIS	141
4.16.3 FACTOR ANALYSIS	142
4.16.4 EXPLORATORY FACTOR ANALYSIS	143
4.16.5 CONFIRMATORY FACTOR ANALYSIS	145
4.16.6 EXPLORING RELATIONSHIPS	146
4.16.7 CHI-SQUARE TEST FOR INDEPENDENCE	147
4.16.8 PEARSON CORRELATION	147
4.16.9 SPEARMAN’S RANK ORDER CORRELATION	148
4.16.10 MULTIPLE REGRESSION	148
4.16.11 CANONICAL CORRELATION ANALYSIS	149
4.16.12 STRUCTURAL EQUATION MODELLING (SEM)	149
<b>4.17 SUMMARY</b>	<b>151</b>
<b>CHAPTER FIVE. ANALYSIS AND DISCUSSION (DESCRIPTIVE ANALYSIS)</b>	<b>153</b>
<b>5.1 CHAPTER OVERVIEW</b>	<b>153</b>
<b>5.2 DESCRIPTIVE ANALYSIS</b>	<b>154</b>
<b>5.3 DEMOGRAPHIC PROFILE</b>	<b>154</b>
<b>5.4 INTERNET EXPERIENCE AND ONLINE SHOPPING</b>	<b>157</b>
5.4.1 INTERNET USAGE	157
5.4.2 INTERNET ONLINE EXPERIENCE	158
5.4.3 PRODUCT CATEGORIES	159
<b>5.5 SOCIAL MEDIA</b>	<b>161</b>
5.5.1 SOCIAL MEDIA USE	161
5.5.2 SOCIAL MEDIA USAGE	162
5.5.3 ACCOUNT OF SOCIAL MEDIA USED FOR PURCHASE ONLINE	164
<b>5.6 DESCRIPTIVE ANALYSIS OF MEASUREMENT SCALES</b>	<b>164</b>
5.6.1 RESULT OF ONLINE SHOPPING (OS)	164
5.6.2 RESULT OF ONLINE SHOPPING EXPERIENCE (OE)	165
5.6.3 RESULT OF SOCIAL MEDIA (SM)	166



5.6.4 RESULT OF ONLINE SHOPPING INTENTION (OSI)	166
5.6.5 RESULT OF SHOPPING ORIENTATION (SO)	167
5.6.6 RESULT OF ONLINE SHOPPING MOTIVATION (M)	168
<b>5.7 SUMMARY</b>	<b>170</b>
<b>CHAPTER SIX. DATA ANALYSIS II</b>	<b>171</b>
<b>6.1 CHAPTER OVERVIEW</b>	<b>171</b>
<b>6.2 INTRODUCTION</b>	<b>171</b>
<b>6.3 THE MEASUREMENT MODEL</b>	<b>174</b>
6.3.1 DATA SCREENING	175
6.3.2. EXPLORATORY FACTOR ANALYSIS	176
6.3.3. CONFIRMATORY FACTOR ANALYSIS	181
6.3.4 INDICATORS OF ASSESSING GOODNESS-OF-FIT	182
6.3.5 VALIDITY AND RELIABILITY	184
6.3.6 FIT INDICES RESULTS	187
<b>6.4 THE MEASUREMENT MODEL WITH SECOND-ORDER WITH MOTIVATION</b>	<b>189</b>
6.4.1 CFA FOR MOTIVATION	189
6.4.2 CONVERGENT AND DISCRIMINANT VALIDITY	195
<b>6.5 STRUCTURAL MODEL</b>	<b>196</b>
6.5.1 TEST THE MODEL AND THE HYPOTHESES	196
6.5.2 HYPOTHESES TESTING RESULTS OF PROPOSED MODEL	198
6.5.3 TESTING THE ASSOCIATION OF PERSONAL INFORMATION ON THE MODEL	201
<b>6.6 SUMMARY</b>	<b>206</b>
<b>CHAPTER SEVEN. DISCUSSIONS</b>	<b>208</b>
<b>7.1 CHAPTER OVERVIEWS</b>	<b>208</b>
<b>7.2 INTRODUCTION</b>	<b>208</b>
<b>7.3 DISCUSSION OF RESEARCH QUESTIONS</b>	<b>209</b>
7.3.1 ONLINE SHOPPING ORIENTATION	210
7.3.2 ONLINE SHOPPING EXPERIENCE	212
7.3.3 SHOPPING MOTIVATION	213
7.3.4 SOCIAL MEDIA	215

<b>7.4 SUMMARY</b>	<b>220</b>
<b><u>CHAPTER EIGHT. CONCLUSION, CONTRIBUTIONS, LIMITATIONS AND FUTURE WORK</u></b>	<b><u>223</u></b>
<b>8.1 CHAPTER OVERVIEWS</b>	<b>223</b>
<b>8.2 THE MODEL</b>	<b>223</b>
8.2.1 THE FACTORS EFFECT ON ONLINE SHOPPING	224
8.2.2 SOCIAL MEDIA HELPS ONLINE SHOPPING ACCEPTANCE MODEL	226
<b>8.3 RESEARCH CONTRIBUTION</b>	<b>228</b>
8.3.1 THEORETICAL CONTRIBUTIONS	228
8.3.2 PRACTICAL CONTRIBUTIONS	229
<b>8.4 RESEARCH LIMITATIONS AND FUTURE RESEARCH</b>	<b>231</b>
<b>8.5 SUMMARY</b>	<b>232</b>
<b><u>REFERENCES</u></b>	<b><u>241</u></b>
<b><u>APPENDIX</u></b>	<b><u>266</u></b>
<b>APPENDIX 1: PHD FLOW MAP</b>	<b>266</b>
<b>APPENDIX 2: ETHICAL APPROVAL</b>	<b>267</b>
<b>APPENDIX 3: QUESTIONNAIRE</b>	<b>268</b>
<b>APPENDIX 4: REGRESSION WEIGHTS: (GROUP NUMBER 1 - DEFAULT MODEL)</b>	<b>285</b>

# List of Figures

Figure 3-1. TRA, Ajzen & Fishbein, 1975 _____	38
Figure 3-2. TPB, Source: Ajzen, 1991 _____	40
Figure 3-3. TAM, Source: Davis, F. (1989) _____	44
Figure 3-4. UTAUT, Source: Venkatesh et al., 2003 _____	47
Figure 4-1. The Research Model _____	119
Figure 4-2. Steps of factor analysis adopted from Rietveld & Van Hout, 1993. _____	143
Figure 5-1 Categories purchase online in the last 12 months _____	160
Figure 5-2 Do you have any social network accounts? _____	161
Figure 5-3 Which social networking website do you most often use? _____	162
Figure 5-4 how much time do you spend using social networking websites? _____	163
Figure 5-5 How often do you log into social media networks? _____	163
Figure 5-6 Which social media websites have you used to shop or make decisions on regarding online shopping? _____	164
Figure 6-1 Measurement model _____	182
Figure 6-2 Measurement model _____	189
Figure 6-3 first -Order for motivation _____	191
Figure 6-4 Second -Order for motivation _____	192
Figure 6-5 Measurement model with second-order with motivation _____	194
Figure 6-6 Paths diagram of hypnotised model standardized estimates _____	197
Figure 8-1 The model _____	224

# List of Tables

Table 3-1. Summary of history of OSAM _____	48
Table 3-2. Summary of the factors affecting online shopping intention _____	49
Table 3-3. <b>The Research Hypotheses</b> retrieved from Mikalef et al., 2012; Zhou et al., 2007. _____	81
Table 4-1. Paradigm approach adapted from Bryman, 2012, Kidd & Kral, 2005 _____	90
Table 4-2. Quantitative versus Qualitative _____	96
Table 4-3. Advantages and disadvantages of online surveys _____	100
Table 4-4. Interval scale _____	105
Table 4-5. Editing survey _____	114
Table 4-6. Variables used in the study _____	118
Table 4-7. Construct measurement adopted from Mikalef et al., 2012; Zhou et al., 2007; Vijayasarthi, 2002. _____	129
Table 4-8. Z-score _____	133
Table 4-9. Sample size for different population sizes adapted from Saunders et al., 2009 _____	133
Table 4-10. Sampling. Source: Central Department Statistic and Information, Saudi Arabia, 2014, Communications and Information Technology Commission of Saudi Arabia 2014 _____	135
Table 4-11. Data error adapted from Saunders et al., 2009 _____	138
Table 4-12. Reliability Test adapted from Fellows & Liu, 2008 _____	142
Table 4-13. Key statistics associated with exploratory factor analysis adapted from Loarie et al., 2009 _____	144
Table 4-14. Key Statistics associated with CFA adapted from Hair et al. (2010) _____	146
Table 5-1 Demographic Characteristics _____	156
Table 5-2 For how long have you been using the Internet? _____	157
Table 5-3 In a typical day, roughly how much time do you spend using the Internet? _____	158
Table 5-4 How many approximately items have you purchased through Internet shopping for the last 12 months _____	159
Table 5-5 how much have you spent on personal online purchases for the last 12 months _____	159
Table 5-6 Measures of Online Shopping % _____	165
Table 5-7 Measures of Online Experience % _____	165
Table 5-8 Measures of Social Media % _____	166
Table 5-9 Measures of Online Shopping Intention % _____	167
Table 5-10 Measures of Online Shopping Orientation % _____	168
Table 5-11 Measures of Online Shopping Motivation % _____	169

<i>Table 6-1 The Construct measurement Mikalef et al., 2012; Zhou et al. (2007); Vijayasarthy and Jones (2000)</i>	173
<i>Table 6-3 Pattern Matrix</i>	177
<i>Table 6-4 Factor Correlation Matrix</i>	177
<i>Table 6-5 Pattern Matrix</i>	179
<i>Table 6-6 Factor Correlation Matrix</i>	181
<i>Table 6-7 Convergent and discriminant validity</i>	186
<i>Table 6-8 Fit indices of measurement model</i>	188
<i>Table 6-9 Model fit indices</i>	193
<i>Table 6-10 Model fit indices</i>	195
<i>Table 6-11 Convergent and discriminant validity</i>	196
<i>Table 6-12 Results of regression estimates for H1, H2, H3 and H9</i>	199
<i>Table 6-13 Result of regression estimate H4</i>	199
<i>Table 6-14 Result of regression estimate for H9</i>	200
<i>Table 6-15 Results of regression estimates for H10</i>	201
<i>Table 6-16 Result of age association</i>	202
<i>Table 6-17 Result of gender association</i>	203
<i>Table 6-18 Result of education association</i>	204
<i>Table 6-19 Result of income association</i>	206
<i>Table 7-1 Proposed Structural Model and Hypotheses Test Results</i>	210
<i>Table 7-2 Summary of testing the moderation</i>	217

# Definitions of Terms

## **E-commerce**

According to Florian et al. (2016) e-commerce (electronic commerce), transfer data or fund over the network. Zhang et al. (2014) define e-commerce as an electronic tool used for business or activities for selling products and services electronically.

## **Online Marketing**

Online marketing is a form of digital advertising and salesmanship that refer to marketing strategy used to market the products or services online include: website, social media, email marketing etc. (Dann, 2010).

## **Online Shopping**

According to Davidow (2010) and Ward (2016), online shopping is the act of buying goods and/or services via online tools such as websites, social media, etc...., without the customer viewing or visiting an actual physical store of the retailer.

## **Online Shopping Acceptance**

The acceptance of online shopping is a continual process that seeks to obtain potential consumers, together with retailer confidence and acquiescence, through the formulation of an Online Shopping Acceptance Model (Flick, 2009).

## **Online Shopping Acceptance Model**

The OSAM is a reference tool used to describe consumer behaviour in terms of acceptance of online shopping (Flick, 2009).

## **Social Media**

Nations (2016) defines social media is commensuration tools that can people interact each other's by sharing, talking, etc....

# Chapter One. INTRODUCTION

## 1.1 Chapter Overview

This chapter justifies the need for this study and provides an overview of its structure. First, the context of online shopping in Saudi Arabia as a developing country is defined. Second, the research problem is clarified by focusing on the Online Shopping Acceptance Model (OSAM) and the use of social media as a specific factor. Third, the research aims, objectives, research questions, and hypotheses are outlined. Lastly, a list of anticipated contributions is presented. The chapter ends with an overview of subsequent chapters.

## 1.2 Introduction

The use of the Internet has spread widely. It has become integral to many sectors of life, and shopping is no exception. Shopping online has become an essential element in commerce in many countries with high Internet penetration (Santos, 2003).

In 2012, the Internet was utilised by an estimated 42% of the world's population (AGG, 2012); however, in the space of four years it reached a historic high of more than 50% (Internet World Statas, 2016). From its first commercial use in the 1990s, it has passed through various stages of intensive development (Howe, 2012; Internet Society, 2016). As the Internet continues to develop across the globe and make its way into homes and businesses (Bughin et al., 2011), not to mention personal mobile devices (Zaki, 2013), it is providing a plethora of opportunities for retailers (Neilson, 2016). With the development of online shopping, a platform was developed whereby customers can buy whatever they want from wherever they wish and whenever they desire (Zaki, 2013). This flexibility is one of the major advantages of shopping online, but value for money is one of the top reasons found in the Nielsen survey (2016).

*“In fact, four of the top five motivators in Saudi Arabia and three of the top five in the US are focused on finding the best possible price.”*

## Chapter One. Introduction

However, online shopping has its disadvantages as well, as consumers must also come to terms with the risks associated with the products and services as well as the online buying process (Ko et al., 2004; Zaki, 2013; Queensland Government, 2016).

The perceived risks of purchasing online are not a new phenomenon, though, as it has been noted that they occur whenever a customer considers the probability of the item getting lost in the mail or some other negative consequence of using or purchasing a product or service (Kim, 2012). These risks existed when customers considered using distance buying, as in mail order shopping (Simpson & Lakner, 1993). These risks include buying from anonymous retailers, the inability to examine the product physically before buying, the loss of time and/or money, the vulnerability of sharing personal and financial information online, and the perceptions of such purchases in relation to the prevailing culture of the consumer's society, including the views of friends and family (Laroche et al., 2005). Such disadvantages can lead customers to lose trust in online shopping. Hence, efforts have been made to maintain a high level of customer trust, which is the pillar of shopping online and, in fact, any type of shopping. "Customer trust" is an essential concept upon which online shopping is based. It involves the customer's trust in the retailers as well as the methods of purchasing the products or services. Therefore, when a customer is making a purchase from an internationally based retailer that is located in a different geographical location and that has a different culture, the perceived risks of shopping online increase (Al-Maghrabi & Dennis, 2011). The lack of perceived risks by a potential customer increases the level of trust in the final purchase decision (Khalil, 2014). The less the risks are, the more trust the customer has.

Trust is a keyword in online shopping because any lack of trust prevents shoppers from engaging in e-shopping. People are unlikely to deal with vendors that do not convey a sense of trustworthiness and reliability. This ultimately creates fear within the customer about a seller's opportunism (Hoffman et al., 1999; Rezaei et al., 2014). Similarly, some researchers have suggested that trust has a positive effect on online shopping intention (Lim et al., 2006) and actual buying decisions. McKnight and Chervany (2001) concur with these views, as they found that the degree of trust satisfies transactional expectations



while also eliminating doubt and perceived risks (Al-Maghrabi & Dennis, 2011; Wang et al., 2016).

Examining customers' perception and acceptance of online shopping is essential because gaining customer trust is a principal factor in the success of any business. Decision makers and business people have sought ways to measure customer's trust and opinions about shopping online in order to improve the service and fill any gaps (Fang et al., 2016). Thus, retailers and academics alike are becoming increasingly interested in customers' perceptions regarding online trust, and when and if consumers will purchase a product or service online (Wang et al., 2012). One way to increase trust amongst potential consumers is to invest in social media communication (Laroche et al., 2016).

Social media enables firms and corporations to interactively converse with customers about their products and services while providing reassurance about their offering (Godes & Mayzlin, 2004; Agarwal et al., 2008). The increasing use of smartphones with Internet data services (Wortham, 2010) has made augmented reality (AR) available in many fields of social media application (Pense, 2011). The concept of showrooming is turning conventional face-to-face shopping into competition with online stores, because if individuals can find the same product online for a better price (Horky & Collier, 2016), why should they spend more money in a physical store? When it comes to developing countries, mobile commerce enables e-commerce where it would not have previously been possible. As illustrated by the findings of the Neilson 2016 survey, poor infrastructure is blamed for the unstable Internet connection:

*“In some developing markets, this figure approaches or exceeds 50%, including in Saudi Arabia (55%), India (52%), Nigeria (49%), South Africa (48%), Mexico and the Philippines (47% each). In these markets, mobile devices have been critical to e-commerce growth, bringing many new and underserved customers online—and their importance will continue to grow.”*

Moreover, consumers who use social media have the power to influence other buyers or sellers by writing reviews of products or services (Ioană & Stoica, 2014). In other words, social media has facilitated interaction between customers and retailers, and makes the

customers' role in the process of offering products more essential (Schivinski & Dabrowski, 2016).

Meanwhile, even though a number of studies have investigated online shopping in developed countries, there is still a shortage of research using these in developing economies (Butt et al., 2016). Studies about information technology (IT) in developing countries are few, and IT has failed to transfer effectively (Ahmed & Bahaziq, 2013; Leonardi et al., 2016). Moreover, the literature documenting online shopping acceptance and growth in developing countries is also deficient and often simply anecdotal (Agwu & Murray, 2015). There is a great need to understand the topic of customers' perceptions and views in research in order to fill the gaps in both knowledge and practice. This research can help in better understanding the special needs of developing countries such as Saudi Arabia and its ability to improve the acceptance of online shopping.

### **1.3 Definition of the Problem**

Despite the acceptance of technology and social media in many aspects of life, Saudi Arabia has not reached an advanced level of technology usage and development in the field of e-commerce, as all economic plans and projects are officially decided by the Ministry of Commerce and Investment. The Ministry's strategies are inadequate to elevate the country's existing condition in the field of e-commerce to meet the global standards (Al-Ghamdi et al., 2012). The Saudi Ministry of Commerce and Investment has established a commission which is tasked with drafting a general plan to introduce e-commerce systems in the country. The outline is intended to address the development of various areas associated with online shopping transactions such as IT infrastructure, security of payment, rules and regulations, and delivery systems (Saudi Ministry of Commerce and Investment, 2016). In 2006, the responsibility for e-commerce in Saudi Arabia was taken over by the Ministry of Communication and Information Technology. Information about this transition was obtained through contact with the Ministry. It was revealed that the Ministry had considered e-commerce, but was in the early stages of examining the subject and had only conducted a general survey regarding the introduction of e-commerce in Saudi Arabia. A

## Chapter One. Introduction

report of the results obtained from this survey was presented in May/June 2013 which demonstrated that 40% of the businesses and 24% of the government organisations in the country make online purchases; however, only 17% of businesses market their products electronically. Consequently, there are lower trends of online shopping in Saudi Arabia than the rest of the world (Khalil, 2014).

According to the latest survey, Internet usage in Saudi Arabia is reaching 65-67%, which is good indicator of growth, with only 40% of Saudi people shopping online in 2012 (STATISTA, 2016) and 46.5% in 2016:

- *“Revenue in the ‘e-Commerce’ market amounted to US\$4.872B in 2016.*
- *Revenue is expected to show an annual growth rate (CAGR 2016-2021) of 12.1% resulting in a market volume of US\$8.642B in 2021.*
- *The market's largest segment is the electronics and media segment with a market volume of US\$1.513B in 2016.*
- *User penetration was at 46.5% in 2016 and is expected to hit 70.7% in 2021.*
- *The average revenue per user (ARPU) currently amounts to US\$465.44.”*

However, if the global statistics are examined, it is found that Hong Kong, Norway, Israel and the US have the highest ratios in the world for online shopping. By contrast, Saudi Arabia ranks 17<sup>th</sup> in online shopping, with the average person spending \$607 per year in on online shopping in 2016 (Chang et al., 2017). There is a large gap between developed and developing countries not only in Internet usage but also in understanding how consumers perceive online shopping. There is also growing interest in examining what factors impact consumers’ decisions to shop or not shop online (Shih, 2004; Lim et al., 2016), and particularly in developing countries such as Saudi Arabia (Brashear et al., 2009).

Despite its position as the world’s greatest contributor to oil production in recent years (OPEC, 2016), Saudi Arabia remains underdeveloped in the arena of e-commerce. Hence, a large number of studies were conducted to determine the factors hindering this development. Of the countries that constitute the Middle East, Saudi Arabia has the 7<sup>th</sup>

## Chapter One. Introduction

fastest growth of communication technology marketplaces, but online shopping activities are not developing at the same pace (World Economic Forum, 2016).

Of the total number of commercial organisations in Saudi Arabia, 35% are involved in e-commerce. The majority are medium and large enterprises from the manufacturing sector (Kearney, 2016). The primary factors hindering the development of online shopping in Saudi Arabia include ICT infrastructure, trust, privacy issues, cultural hindrances, and the absence of sound legislation, regulations, rules and procedures regarding the protection of the rights of all parties involved (Alfuraih, 2008; Neilson, 2016).

Al-Solbi and Al-Harbi (2008) espoused that the challenges to online shopping have increased due to a lack of proper e-commerce regulations, legislation and rules to ensure proper monitoring and regulation of the process. Saudi Arabia has tried to contribute to e-commerce efforts championed by UNCITRAL; however, the government of Saudi Arabia needs to incorporate more developments within the e-commerce avenues by developing more regulations, legislation and rules geared towards protecting the rights of all parties interested in online shopping transactions in the country (Al-Maghrabi & Dennis, 2011; Neilson, 2016).

There are just a few countries that have experienced financial and social transformations as dramatic as Saudi Arabia. What was, amid the 1960s, an overwhelmingly migrant culture, is currently 95% settled down, with 80% of the populace living in urban areas (GMI, 2016).

In this developed Saudi Arabia, social networking has become a major force. Now, Saudi Arabia has the highest penetration of Twitter users, and per-capita utilization of YouTube is the highest in the world (GMI, 2016).

Consequently, there is a need to track the use of social media in online shopping and trace the factors behind adopting/rejecting online shopping in Saudi Arabia.

### **1.4 Research Gap**

There are a number of theories around information systems, as will be discussed in the literature review. One in particular is the Technology Acceptance Model (TAM), where the element of diffusion focuses on the acceptance and use of the Internet (Al-Maghrabi et al., 2012). This model aims to depict the ways in which individuals come to use new technology and the factors that influence their decisions. The primary influencing factor of this model is usefulness to the user and ease of operation (Al-Gahtani, 2014). This means that individuals accept a technology more thoroughly if they are aware of its usefulness and can use it easily.

However, one of the problems with TAM is that it is not specific to a particular area of technology but applies to various areas of the technology sector (Savitskie et al., 2007). According to Annamalah (2008) and Aladwan and Smedley (2013), the TAM was used successfully by many researchers to study the adoption and acceptance of Internet technologies. Theorists who have used the TAM have been capable of extending the model to more specific areas, such as online shopping, which has led to the development of other models such as the Online Shopping Acceptance Model (Zhou et al., 2007). Many studies have applied the TAM in the Middle East, but none have applied OSAM; therefore, theoretical and practical research is needed to fill the gaps in the online shopping literature (Hidayat et al., 2016). The theoretical model used to analyse the data in the current study will be based on the OSAM as developed by Zhou et al. (2007). This model of acceptance examines customers' views and opinions about products and services in order to improve or replace them.

### **1.5 Research Aim and Objectives**

#### **1.5.1 Aim**

As outlined above, there is currently a need to use the OSAM in a Saudi Arabian context and to **explain** the additional factors of social media use. It is also important to find out how online shopping can be expanded in countries that have developed physical infrastructure and restrictive marketing (Zaki, 2013). The greatest benefit that IT offers to

## Chapter One. Introduction

an emerging nation like Saudi Arabia is the opportunity (Al-Ghamdi, 2011) to expand and develop its economy through online shopping and other social media. Therefore, this study aims to **explain** the acceptance of online shopping in Saudi Arabia using OSAM and the additional variable of social media.

### **1.5.2 Research Objectives**

This study has two primary objectives:

- To learn about the growth of online shopping in Saudi Arabia and how the concept has become more popular through OSAM; and
- To understand how social media has played a role in the growth of online shopping in Saudi Arabia.

### **1.5.3 Research Significance**

The research will bring about better understanding of the potential of the Saudi online shopping marketplace, what factors influence customers to shop online over conventional malls, and whether the infrastructure to support such functions is in place. Such information can be useful to those who want to invest in the sector as well as consumers who may be encouraged to shop online more.

### **1.5.4 Research Questions**

- What factors affect online shopping acceptance in Saudi Arabia?
- What role does social media play in the acceptance of online shopping in Saudi Arabia?

### 1.5.5 Hypotheses

These OSAM hypotheses are modified from the original work by Zhou et al. (2007) and Mikalef et al. (2012) by introducing the Saudi Arabian context and social media:

**H1:** Shopping orientation (SO) is positively associated with online shopping intention (OSI).

**H2:** Motivation (M) is positively associated with online shopping intention (OSI).

**H3:** Online shopping intention (OSI) is positively associated online shopping (OS).

**H4:** Online shopping experience (OE) is positively associated with online shopping intention (OSI).

**H5:** Age is negatively associated with online shopping intention (OSI) through shopping orientation (SO).

**H6:** Education is positively associated with online shopping intention (OSI) through shopping orientation (SO).

**H7:** Income is positively associated with online shopping intention (OSI) through shopping orientation (SO).

**H8:** Gender is positively associated with online shopping intention (OSI) through shopping orientation (SO).

**H9:** Age is negatively associated with online shopping intention (OSI) through shopping motivation (M).

**H10:** Education is positively associated with online shopping intention (OSI) through shopping motivation (M).

**H11:** Income is positively associated with online shopping intention (OSI) through shopping motivation (M).

**H12:** Gender is positively associated with online shopping intention (OSI) through shopping motivation (M).

**OSAM and Social Media**

**H13:** Social media (SM) is positively associated with online shopping intention (OSI).

**H14:** Age is negatively associated with online shopping intention (OSI) through social media (SM).

**H15:** Education is positively associated with online shopping intention (OSI) through social media (SM).

**H16:** Income is positively associated with online shopping intention (OSI) through social media (SM).

**H17:** Gender is positively associated with online shopping intention (OSI) through social media (SM).

**H18:** Social media is positively associated with online shopping (OS) through online shopping intention (OSI).

**H19:** Shopping motivation (M) is positively associated with online shopping intention (OSI) through social media (SM).

**1.6 Thesis Structure**

This thesis is organised into seven chapters – Introduction, The Saudi Arabian Context, Literature Review, Methodology, Descriptive Analysis, Hypotheses Test, and Discussion and Conclusions.

In Chapter 1, the topic of online shopping is introduced and the background and motivation of the study established. Additionally, this chapter outlines the online shopping experience by providing definitions pertaining to the study that introduces the subject.

Chapter 2 provides a contextual overview of online shopping in Saudi Arabia and its development. This chapter discusses the context of Saudi Arabia to understand the nature of e-commerce, the e-mall, social media and retail commerce in Saudi Arabia.

The literature review, Chapter 3, investigates the OSAM and consumer demographics together with online shopping intention and experience. This chapter provides a deeper



## Chapter One. Introduction

analysis of the aspects that enhance further understanding of the online shopping process, and the extent of the impact of social media on online shopping.

The methodology, Chapter 4, identifies the research method used. It further justifies the research strategy decisions made for data collection in line with the research aims and settings. This chapter incorporates the exploratory phase of the quantitative method, which enhances the research process, rendering it more effective and efficient through the inclusion of readily measureable elements.

Analysis of the findings is divided between Chapters 5 and 6. Chapter 5 features an analysis of the results derived from the data collected from the online survey. Also, it provides statistical data analysis on the data discussed through tables, graphs and charts. The data analysis process selected provides statistical evidence that facilitates the development of the OSAM.

Chapter 6 provides a detailed description of the procedures and steps undertaken in applying the Structural Equation Model (SEM) for testing the research hypotheses and the research model. This chapter also describes the procedure undertaken to evaluate the validity and reliability of each construct as well as the model's fit through the indices produced from SEM results.

The discussion, Chapter 7, provides an analysis of the results found from primary data collection and those identified in the literature review. Discussion of the research findings in this chapter identifies the strategy of the social media used in online shopping in Saudi Arabia.

Finally, the conclusion presents the main findings of the thesis. Also, it provides a review of the hypotheses, which represent the study's contributions to the literature based on the theoretical and practical contributions and how these should be interpreted by future researchers. The study's limitations and directions for future research are also discussed.

## **Chapter Two. THE CONTEXT OF SAUDI ARABIA**

### **2.1 Chapter Overview**

This chapter presents the context of Saudi Arabia and explains the role and importance of online shopping in Saudi Arabia. First, a background of the country is provided. Internet marketing, its importance and present developments are addressed. Subsequently, this chapter reviews the use of information and communication technology, retail commerce, electronic commerce, e-malls, and online customer behaviour and intention in Saudi Arabia. This is followed by an overview of social media in Saudi Arabia and previous research on online shopping in the country.

### **2.2 Background**

From 1932 to 1950, Saudi Arabia was considered a poor and struggling country whose economy was greatly reliant on agricultural production and annual Islamic pilgrimages. Once oil trading started in the 1940s, the country opted to improve its physical infrastructure (Al-Rasheed, 2010). Utilizing its oil fields during the world oil crisis in 1973, the country earned significant revenue. It became a member of the World Trade Organization in December 2005.

Saudi Arabia is the homeland to the religion of Islam and includes two of the most sacred Islamic cities – Makkah and Madinah. Islam provides the fundamental system of state governance, and dominates people’s individual and social lives (Saudi Ministry of Foreign Affairs, 2016). The country had a population of 31 million in 2016, 6 million of whom were immigrants living in an area of 2,149,690 square kilometres. The country’s annual per-capita income was approximately \$20,487 in 2015. Twenty-one million of the Saudi population use the Internet.

Saudi Arabia is largely traditionalist, as religion and Arab culture are deeply infused in people’s lives (Al-Rasheed, 2010). However, while the Middle Eastern region owns one of

the largest and emerging IT industries in the world, Saudi Arabia lags far behind the latest developments in the field of e-commerce (Al-Ghamdi et al., 2012). Accordingly, there is an urgent need to conduct research to discover the factors that influence customers' approval and interest in online shopping and to determine the underlying impediments towards it, particularly in Saudi society and culture (Xu et al., 2016).

### **2.3 Saudi Economy**

A major part of Saudi Arabia's economy is reliant upon oil revenue, which is completely controlled by the central government. The country owns about 16% of the world's reserves of petroleum, is the biggest exporter of petroleum, and is a significant member of OPEC. In 2016, the petroleum sector of the country comprised:

- 80% of all financial plan revenues;
- 45% of GSP; and
- 90% of all export earnings.

To further expand its economy and provide employment opportunities to its citizens, Saudi Arabia is working to develop the private sector in terms of:

- Power-generated telecommunication;
- Natural gas exploration; and
- Petrochemical sector.

Approximately 9.6 million immigrants in 2015 worked in industry, employed mostly in the oil and service sectors and education. Due to this large number, the authorities are working in Riyadh to decrease the unemployment rate among Saudi nationals. The focus of the government is on the youth of Saudi Arabia because they lack adequate levels of education and technical skills, which are required for employment in the private sector. In 2014, Saudi Arabia faced its first budget deficit since 2009.

Saudi Arabia contains the most stable economy among all countries of GCC, having a GDP of USD\$1.679 trillion in 2016. The tax rates imposed upon citizens are as low as 0%, which helps to augment the amount of finances each family has available to purchase goods and

services that are available online. Moreover, Saudi Arabia offers a range of online marketing opportunities for both customers and retailers. According to the most recent report by the Ministry of Commerce and Investment in 2016, around 5 million Internet users in Saudi Arabia purchased online goods and services worth approximately \$9 billion in 2016. The most widely purchased goods were electronic products and software, while the most extensively used services were airline tickets and hotel reservations.

Hence, Saudi Arabia can be considered as one of the larger e-commerce markets in the Middle East. Although the Saudi e-commerce market is quite developed, it is expected to grow further in the next few years due to the increased use of online shopping, which is worth around \$13.5 billion (Ministry of Commerce and Investment Report, 2015).

### **2.4 Information and Communication Technology in Kingdom of Saudi Arabia**

The economy of a country relies greatly upon information and communication technology (ICT). The first decade of the 21<sup>st</sup> century in Saudi Arabia marked the development of a subsistent ICT infrastructure (Brdesee et al., 2012). In the last few years, the Saudi government has effectively addressed these considerations and become the main and most rapidly developing oil market in the Arabian state (Sullivan, 2016).

In 2011, 83 billion Saudi Riyals were spent on the ICT sector (CITC, 2016). IT spending is expected to increase to a yearly growth level of about 11.4% in 2015, which requires to maintain growth rates over the coming years. This fast growth rate has been stimulated by the high rates of expenditure in hardware and ICT services (CITC, 2016). Currently, the Saudi government opted to further develop the ICT infrastructure by privatizing the telecommunication sector (International Monetary Fund, 2016). The Saudi government in 2001 established the Communication and Information Technology Commission (CITC), which aimed at regulating the ICT sector by following up on a particular set of rules. The commission had the following goals:

- *“Facilitating modern, adequate, and reasonably priced communications services;*
- *Give rise to an environment of fair competition;*

## Chapter Two. The Context of Saudi Arabia

- *Making effective use of the available frequencies;*
- *Conveying telecommunications technology to keep track of the pertinent development and ensuring comprehensibility and directness in the underlying processes;*
- *Effectively following up on the principles of impartiality and fairness; and*
- *Safeguarding the interest of the public as well as that of users and stakeholders.”*

The Saudi government in 2003 formulated an autonomous ministry called the Ministry of Communications and Information Technology (MCIT). This ministry aimed to regulate the ICT sector, while ensuring its effective functioning and expansion of its services to bring development in the socio-economic structure of the country, which would result in progress of the country and its people (MCIT, 2016).

**Despite some opposition from conservative circles who often oppose drastic change. Saudi Arabia’s mobile subscription rate is one of the highest in the world.** In 2016, 51 million mobile subscriptions were made in the country by 160% of the population. (MCIT, 2016).

The increased number of mobile subscription caused a decline in the usage of residential fixed phone lines. The average usage ratio decreased to 16% for a population of 4.49 million, which is lower than the global average. The Arab mean of 10.5% is less than 17.8%, and the average for developing countries is 13.5% (MCIT 2016). **However, it is the growth of Internet subscription services that is of greatest interest. The number of Internet users has grown from 16.5 million in 2013 to 20 million in 2016** (MCIT, 2016). As Internet access and usage are among the key factors influencing people’s interest in e-commerce (Sait et al., 2004), the following paragraph addresses details about them from Saudi Arabia. Internet users can freely contact the Saudi Communications and Information Technology Commission (CITC), demanding that they block or unblock any website or webpage. They submit requests by filling out special forms, which are then processed by the commission and approved if they do not breach any rule or regulation (CITC, 2016). One example of websites being banned are competitive telecommunication offers (e.g., <https://www.vpn-accounts.com/saudi-arabia-Internet-censorship.html>). As with many other technologies, there are ways to circumvent censorship such as Virtual Private Networks and Internet Service Providers from foreign countries.

## Chapter Two. The Context of Saudi Arabia

Broadband memberships in Saudi Arabia increased to nearly 26.6 million for altered broadband lines accessible to around 42.9% of family units, and about 20 million for portable broadband for 49.6% of the public in mid 2016 (MCIT 2016). Settled broadband administrations incorporate DSL, fibre optic and other altered lines.

The CITC have declared that Internet users now comprise a key portion of Saudi society. Nearly 96% of local Internet users view the Internet as an essential wellspring of data and diversion. Undergraduates are urged to use the Internet as their schools tend to utilize a greater amount of Internet time than others (CITC, 2016).

### **2.5 Retail Business in Saudi Arabia**

The yearly population growth rate has increased by 3.2% in the past decade. This increase is one of the factors responsible for developing the Saudi Arabian market and marking its place in the Middle East (Trading Economic, 2016). According to the World Economic Forum (2016), Saudi Arabia is the 7<sup>th</sup> largest and most rapidly developed trade market in the world. In 2016, its retail trade capacity surpassed SAR 90B (SAR 3.75= US\$1), which amounted to 70B. In 2015, the Saudi retail market capacity reached SAR 370B, comprised of small and medium-sized companies, which represented 85% of the total market share (Aljazira Capital, 2016). It is expected that by 2020, Saudi retail sales will reach SAR 445 billion (Aljazira Capital, 2016).

The global retail development index in 2016 ranked Saudi Arabia 8<sup>th</sup> in the world. The country has an emerging retail market with a firm economy. In the last few years, the hypermarket and supermarket sectors of the country developed significantly. This development corresponds to the interventions of foreign actors and the diversification of local actors. The past ten years brought international apparel retailers to the country through local partnerships (Kearney 2016). However, even the international retailers are regulated by the government policies. According to Saudi Arabia's imported rules of investment, more than 25% of capital is required to be possessed by the international retailer. Moreover, the hours of operations of these stores during religious periods are also regulated by the government, demanding that the stores dim their lights or close for prayer

times. Nonetheless, international retailers are considered an important part of the development of the market (Kearney, 2016).

Each company has different business hours, but many businesses operate either from 5 pm to 9 pm or 8 am to 3 pm. During Ramadan, which is the month of Islamic fasting, these times are altered to 9 am to 3 pm and 8 pm to 3 am. The weekend is Friday and Saturday, and working days are from Sunday to Thursday.

### **2.6 E-Commerce**

According to the Hub of the Ministry of Commerce and Investment in the KSA (2016), the first e-business committee was founded in 1999. This is one of the government's strategies to accept and utilize the e-commerce structure. Like the online trading amount, various dilemmas have promoted the involvement of the government in the Internet.

According to the Ministry of Commerce and Investment (2016), the e-business committee in Saudi Arabia was chosen to calculate fundamental infrastructural requirements related to security, communication, technical, and legal dilemmas. Many other ministries and departments were included in this committee; however, due to the government bureaucratic system, new legislation and the process of adaption are highly time-consuming.

With the increase of almost 3.9% each year, the rate and speed of development in the business sector increased in the past years (SAAB, 2016). According to AMEinfo (2008) the appearance of e-commerce is the main reason behind this expansion and growth. According to CITC (2016), many companies utilize the Internet in their business. The outcomes mentioned below were obtained in the literature regarding the utilization of e-business within the private segment in KSA, as stated in CITC (2016).

- 1) The size of the company is related to who owns the website, and approximately four out of every ten firms own a website and have an Internet connection.
- 2) Information related to the company is sometimes displayed on the website along with news and information about their services, goods and events.
- 3) With the remaining company websites utilizing both English and Arabic, almost 56% of all sites are hosted in English only.

- 4) Both foreign and local domain names are generally utilized, and there is no distinct preference for website hosting. Nonetheless, in order to allow companies to communicate better with consumers, companies favour the use of local domains.

The scarcity of e-commerce in the commercial sector was highlighted in many studies, and only one of out every ten companies use e-commerce. According to CITC (2016), the reduced uptake of online shopping differs greatly from the number of companies that have a website, which is 65%.

The reasons are recognized as follows:

- There is a possibility that companies have insufficient funds to build interactive websites that enable buying and sales transactions. The company might utilize websites like eBay and choose to collaborate with an e-broker or e-mall.

According to Alshehri et al. (2012), there are some problems and dilemmas that are faced by the Saudi government. There is a scarcity of experienced people even though the government has the financial resources to fund the project.

### **2.7 E-Malls in Saudi Arabia**

According to Timmers (1998), digital platforms that facilitate interaction between customers and retailers are called 'electronic markets' (e-malls). As stated by Asfoura et al. (2009), they serve as an electronic interface to facilitate businesses that offer various important services via the Internet. These facilities include organizing procurement, provision, and delivery systems. Moreover, as Zimmermann (1997) stated, a local marketplace of international goods for one place or many adjacent areas can be defined as an e-mall. According to Laudon and Traver (2007), the provision of a vast range of informational kinds of exchange and interaction by using electronic means includes the most significant advantages of e-malls for companies.

Hence, the transactions that occur between companies and consumers are followed up by brokers from the e-malls (Bahaddad et al., 2015). According to Asfoura et al. (2009), by providing distinct policies that customers must agree to in order to take part in the e-malls, these arenas offer a sound environment for transactions. Additionally, helping with the



presentation of commercial goods of many vendors while facilitating the effortless comparison of costs and characteristics, these e-malls play the role of huge networks (Bahaddad et al., 2015).

According to Informix (2000), the products and services that an e-mall offers should be listed clearly. Amazon.com (2010) states on the first page of the website the main subcategories, such as sports, garden supplies, household products, video games, software, clothing and hardware. According to Ward (2016), various marketing techniques like Facebook, Twitter, YouTube and Instagram should be provided by e-malls so that connections with the customers can be augmented. Furthermore, the intention to continuously augment the number of consumers who are willing to buy and trust these websites is augmented through conferencing.

On the basis of research that was conducted involving the customers of a Saudi Arabian Internet services unit, 56% utilize and trust foreign market websites but only 8% of the population uses Arabic sites. However, a few e-malls have become popular in Saudi Arabia. The most popular are the Saudi Post e-mall (email.com.sa), Haraj.com and Souq.com.

Moreover, there is a dearth of studies on Saudi Arabia, and most are on the subject of the creation of e-commerce, such as Bahaddad et al. (2015), who studied the factors attracting online consumers to choose e-malls. According to Al-Ghamdi et al. (2011), however, the amount of research that specifically focuses on the sub-prototypes of e-business such as B2B and B2C is quite low. In addition, companies make agreements with e-malls as an alternative to developing an e-commerce site of their own.

### **2.8 Social Media in Saudi Arabia**

Saudi Arabian people started using social media like other countries in the region. Indeed, the utilization of social media has attracted millions of Saudis (GMI, 2016). Social media has turned into a critical form of correspondence and collaboration between people in Saudi society, particularly among younger people. It has become an everyday activity among the

## Chapter Two. The Context of Saudi Arabia

youth in Saudi Arabia (GMI, 2016). According to SimilarWeb (2016), YouTube, Twitter and Facebook were the top social networks in 2016, and there has been an increase in active accounts from 6 million in 2012 to around 11 million in 2016. The top four social media applications in 2016 were WhatsApp, Facebook, Skype and Snapchat (GMI, 2016).

Global Media Insight (2016) reported that Facebook in 2016 had more than 7.9 million clients from Saudi Arabia, up from 6 million in 2012. Additionally, the quantity of Twitter clients is expected to approach 6 million dynamic clients in Saudi Arabia (GMI, 2016). This study inferred that Twitter had three million dynamic clients in 2012. Regardless of the ubiquity of Facebook and Twitter in Saudi Arabia, the utilization of social media is still new to many organizations.

Many researchers believe that businesses in Saudi Arabia still do not realize the power of social media as a marketing tool (Saleh, 2016). For this reason, researchers argue that businesses need to change their way of communicating with the public and start using social media to keep up with the interests of the public (Saleh, 2016). Moreover, they argue that social media can create an advantage for businesses by shifting the nature of communication with the public from the traditional way to a more developed and direct approach.

Saudi women entrepreneurs are using social media tools to market their handmade products or home-based catering services in order to generate income (Wally, & Koshy, 2014). Most women in Saudi business appear to utilize online networking platforms such as Twitter, Facebook, and Instagram, to target whatever number of intrigued customers can be reached under the circumstances. The utilization of social media platforms to market items and for administration is especially appealing to women in Saudi Arabia for various reasons. First, notwithstanding the expansion in the quantity of women with post-auxiliary degrees (e.g., graduate or undergraduate degrees), the inclusion of women in the workforce is still restricted due to the special social attributes of Saudi society (Wally, & Koshy, 2014). The utilization of social media-based business (SMBB) can give access while ensuring their protection, privacy, and security. Furthermore, the utilization of SMBB enables women to stay physically close to their families, in order to watch after the family unit. Lastly, there is the

matter of start-up expenses. Making a SMBB is less costly than making and maintaining an expert online site (Wix.com, 2013 and Shopify.com, 2013) or brick-and-mortar store.

### **2.9 Why Study Online Shopping in the Kingdom of Saudi Arabia?**

Since the beginning of the Internet, the Internet has continually developed, through online data, business, stimulation, and long-range interpersonal communication. In 1991, the Internet had less than three million clients globally and no e-trade applications. By 1999, around 250 million clients were on the Web, and 63 million of them were occupied with online exchanges, which created an aggregate estimation of USD\$110B (Coppel, 2000). In this manner, the Internet stands out amongst as being among the most powerful advances that have built up the e-trade.

### **2.10 Summary**

This chapter presented an overview of the online shopping context in Saudi Arabia. The principle topics that emerged are the importance of studying Saudi Arabia. This was approached by describing the Saudi economy and statistics on Internet penetration and the use of social media as well as top websites in 2016.

Despite being one of the fastest-growing technology industries, there was little growth in online shopping in Saudi Arabia. The role of social media, and the needs, wants, and preferences of Internet users in Saudi Arabia have yet to be examined in academia. There has not been a study on online shopping **acceptance** through the use of social media from the new technology acceptance approach (Al-Maghrabi et al., 2012).

There were some comments in the literature suggesting that online strategies should not ignore either the direct or indirect effects on online shopping acceptance. Moreover, the results support others studies which found that usefulness mirrors the utilitarian sides of online shopping. Therefore, this research attempts to identify new strategies that can support the adoption of online shopping in Saudi Arabia. Building on this, the next chapter presents a literature review on the online shopping acceptance model (OSAM).

## **Chapter Three. LITERATURE REVIEW**

### **3.1 Chapter Overview**

The previous chapter introduced the research setting and challenges faced by online shoppers in Saudi Arabia. This study was built on the online shopping acceptance model (OSAM), which is described and justified in this chapter. The first section addresses the historical background of OSAM and its developmental theories. The next section describes the OSAM factors, such as online motivation and consumer demographics. The last section focuses on the model derived from the new factor of social media examined in this study.

### **3.2 Development of the Online Shopping Acceptance Model**

OSAM was developed out of contributions by a number of theorists as an extension of the Technology Acceptance Model (TAM), Theory of Reasoned Action (TRA), and Theory of Planned Behaviour (TPB) (Flick, 2009). The development of OSAM resulted from various consumer features, which were essential in defining the conglomeration of factors that shaped consumers' acceptance of using TAM (Flick, 2009). These factors included online experience, demographic factors, shopping orientation, Internet experience, personal traits, shopping motivation, normative beliefs, and online shopping experience (Flick, 2009; Zhou et al., 2007). In accordance with other studies on the subject, there was some consistency regarding the impact of these factors. This has led to the classification of some of these factors into categories that then determined online shopping acceptance models (Zhou et al., 2007).

#### **3.2.1. Theory of Reasoned Action (TRA)**

In 1980, Ajzen and Fishbein came up with the Theory of Reasoned Action (TRA). This theory was initially incorporated into social psychology. It was utilized predominantly in providing explanations for individual behaviour (Ajzen & Fishbein, 1980). The theory was

## Chapter Three. Literature Review

developed as a consequence of the expectancy value models. Ajzen and Fishbein pioneered the development of the theory during their efforts to enhance understanding related to the inconsistency between outlook and behaviour. The TRA posited that attitudes toward a behaviour and subjective norms (i.e., the influence that other people have on a person's attitudes and behaviour) are major predictors of behavioural intention (Kim, 2012).

In general, individual behavioural intentions aim to provide positive results of actual behaviour. Moreover, attitudes pertaining to an individual's behaviour comprise one's evaluation of the realized behaviour (Kim, 2012; Fakultas, 2014). This attitude is influenced by an individual's beliefs about the benefits and costs of incorporating the behaviour. For example, a customer may shop online to save money such as fuel costs and time by staying home instead of driving to a shopping mall. The person realizes that their time has value and spending it on shopping in person may incur an opportunity cost they would rather avoid by purchasing goods or services virtually. This was argued by Kim (2012) and Fakultas (2014). In this case, the consumers' beliefs influence their attitudes as well as their behaviour. Moreover, according to Kim (2012), a positive attitude toward online shopping is shaped by several factors: 1) an individual's perception of the product, 2) one's shopping experience, 3) customer service, and 4) consumer risk. These beliefs stem from an individual's evaluation of various opinions pertaining to online shopping from their spouse, parents, siblings and/or friends.

On the other hand, several studies have illustrated that certain attitudes towards online shopping positively influence actual online buying habits (Bigne-Alcañiz et al., 2009; Fang et al., 2016; Lee et al., 2007). For instance, Cho (2004) incorporated the TRA to establish a model for e-shopping behaviour. This operates under the assumption that one's personal attitude towards e-shopping is influenced by one's prior experiences in the digital marketplace, which includes attitudes toward other shopping channels and the option of abandoning an intended online transaction. Furthermore, Ha (2012) integrates the constructs of innovation diffusion theory, thereby developing the hypothesis that one's attitude toward e-shopping is influenced by one's insights into e-shopping's relative benefit, compatibility, and difficulty. In other words, if a consumer has a largely favourable

attitude toward e-shopping based on past experiences and perceives online shopping as more convenient and costing less, that person will likely purchase products or services online (Agag & El-Masry 2016; Ajzen & Fishbein, 1975; Ha, 2012).

Figure 3.1 illustrates the TRA, showing that individual behaviour is influenced by attitudes and subjective norms, which create behavioural intentions that shape behaviour. Subjective norms are explained by Furnham (2005) when he refers to *"the perceived pressure from significant others to perform or not perform the behaviour"* (p. 34).

In the case of online shopping, subjective norms are the pressure placed by others on the customer to buy or not to buy the product or service. Attitudes are also influential in determining behaviours, as Figure 3.1 shows. An individual's subjective norms and attitudes influence and guide the individual's behaviour. For example, people with negative attitudes towards shopping online are predicted not to shop online.

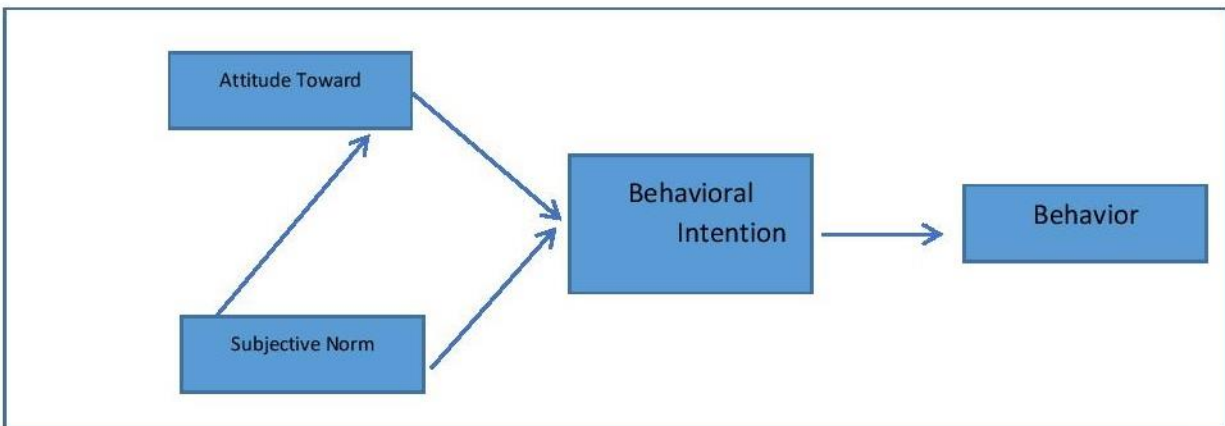

**Figure 3-1.** TRA, Ajzen & Fishbein, 1975

### 3.2.2 Theory of Planned Behaviour (TPB)

The main difference between the TPB and TRA is that the TRA was seen to have too many limitations and thus a third element was introduced – namely, the concept of perceived behavioural control. This led to the creation of the Theory of Planned Behaviour (Ajzen, 1991). The TRA proposes that a person's behaviour is directly influenced by his/her

## Chapter Three. Literature Review

intention to perform the behaviour and that this intention is, in turn, influenced by his/her attitude toward the behaviour and his/her subjective norm. In other words, the TRA demonstrates that when a behaviour is positively assessed by a person and when others are expecting them to behave in such a manner, it will lead to their higher intention and motivation to do so. Theoretically, the components of TRA are attitude, subjective norms, behavioural intentions, and subsequent behaviour.

It was discovered that behavioural control does not always sway actual behaviour. As an attempt to resolve this limitation, Ajzen (1992) introduced TPB by coming up with another constituent component referred to as an 'apparent social regulator'. TBP and TRA thus share many similarities, but TBP is more of an improvement of TRA.

In real-life situations, an individual may have the required positive attitude, subjective norm, and the behavioural intention to purchase online, but he/she may be limited by the lack of network, network skills, or knowledge of how to use the various payment gateways found online. These factors may prevent an individual from engaging in online shopping, even if they have the behavioural intent.

Psychologists such as Ruotsalo et al. (2015) conducted studies on interactive control and its impact on behavioural intent and real behaviour. Behavioural control refers to a person's perception about the difficulty of performing a certain act (Ajzen, 1991). TPB postulates that one's behavioural presentation is reliant on, and may be foretold by, one's interactive intention and perceived interactive control. Ruotsalo et al. (2015)'s TRA espouses that one's conduct is influenced by interactive intention where behavioural aims identify a task of one's attitude toward the behaviour and the personal customs surrounding the presentation of that behaviour (Ajzen, 1991).

Hansen et al. (2004) used both the TRA and TPB in their study. Their findings supported that the TPB, through integration of an added path from personal norm to outlook, provided an explanation of the greater amount of difference in virtual grocery buying in comparison to TRA. Likewise, the behavioural regulator involved analysing the site's ease of use by analysing the factors that make a site attractive and easy to use, like merchandise depiction, business effectiveness, and navigation capability. Even though Shim et al. (2001) utilized

this theory, they overlooked the influence of personal customs. Moreover, Shim et al. (2001) in a study of online prepurchase intention models conducted in the US, worked under the assumption that perceived behavioural control indirectly affected consumers who wanted to shop online with the aim of using the Internet while searching for information. Figure 3.2 illustrates the relationship between consumer attitudes, intention, and behaviour. In fact, a cyclical relationship is cultivated, whereby each factor plays off the others to drive consumer outcomes.

It can be noticed by comparing Figures 3.1 and 3.2 that a new element was introduced in Figure 3.2 – perceived behaviour control. This refers to the supposed likelihood to do what one is used to, and depends on the perceived beliefs and biases that may or may not support a behaviour (Steg et al., 2012).

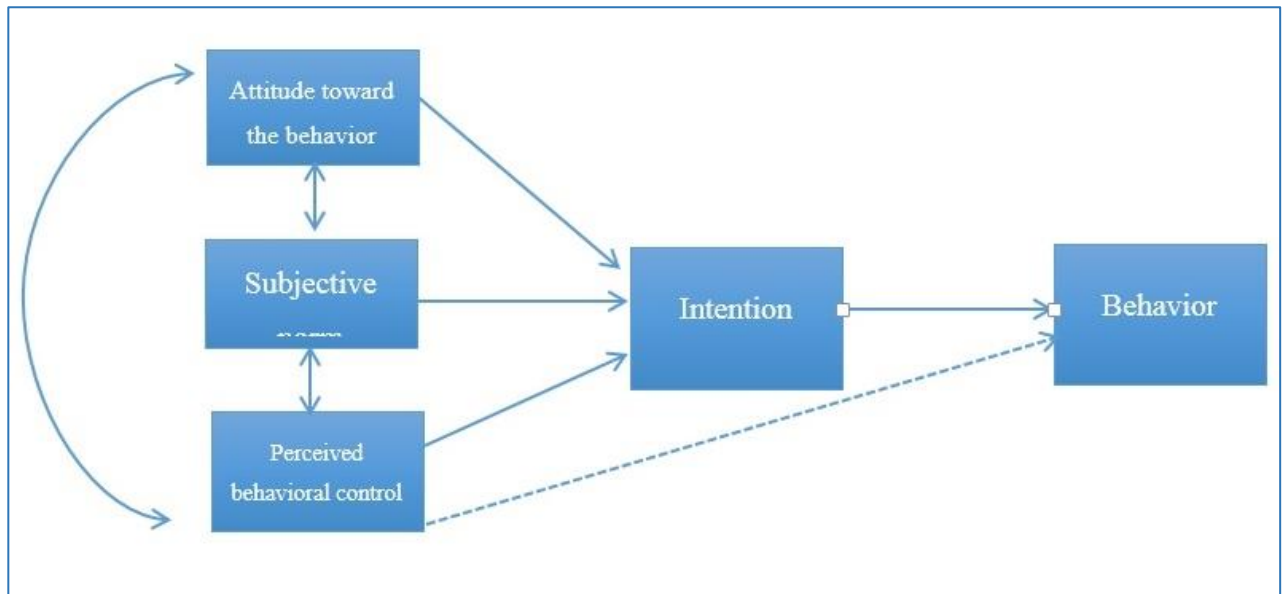

Figure 3-2. TPB, Source: Ajzen, 1991

### 3.2.3 Technology Acceptance Model

The theories of the TRA and TPB led to the development of the TAM, which predicts that user acceptance of technology is determined by three factors: usefulness, ease of use, and



## Chapter Three. Literature Review

behavioural purposes (Teo, 2011). The TAM is one of the most widely used theories that has been tested and critiqued in various research (Wu & Ke, 2016). Past studies on the acquisition of technology and diffusion of innovation focused on the acceptance and usefulness of the Internet (Mortenson & Vidgen, 2016). Davis et al. (1992) introduced this theory to forecast the acquisition and application of information technologies. The theory has come to apply in the present day to the development of applications on various operating systems. The TAM is an economical and influential model used to predict the acceptance of users of these technologies. Since the current e-commerce environment is run by technology, researchers employ this model to predict the acceptance and application of online channels (Ashraf, 2014; Pavlou, 2003).

Results of research studies related to TAM offer a synopsis of the causes of the acquisition and use of e-commerce. The TAM has been widely used by researchers to explain why consumers adopt online shopping, given that the model has a reliable aptitude to elucidate an important quota of variances that exist between social intent and real behaviour. This resulted mainly from investigation into technology product acquisition (Bobbitt & Dabholkar, 2001; Goldsmith, 2002; Grabner-Kräuter & Kaluscha, 2003; King & He, 2006; Park, 2009; Wu & Ke, 2016).

In a Saudi Arabian study, notions of trust, risk, and experience were all found to contribute to shape the intent and behaviour of online shoppers (Abed et al., 2015). Unlike most consumers, shoppers in Saudi Arabia liked the idea and practice due to its convenience and speed, but were cautious about integrity and receiving the goods they ordered. This was mainly because they were used to brick-and-mortar supermarkets where they can physically check the goods for defects (Al-Mowalad et al., 2012). This trend echoes what the TAM asserts. The attitude of users towards adopting technology is highly dependent upon their perception of the usefulness and simplicity of technology. As a result, this affects their intentions based on behaviour, and eventually determines acceptance and use (Meuter et al., 2005; Ashraf, 2014).

According to Ha (2012), the faith that users have in a system is enhanced by how the site is presented. This is referred to as 'perceived usefulness' (PU), while the extent to which

## Chapter Three. Literature Review

consumers trust that the system's use will be struggle-free is known as 'perceived ease of use' (PEOU). In this situation, PU refers to experiential outcomes while PEOU refers to the developments regarding outcomes (Perea et al., 2004). In other words, there is an increased use of the Internet by consumers if they perceive the experience as easy and useful (Teo et al., 1999; Ha, 2012). Venkatesh and Davis (2000) argue that if the system is easier to use, then its usefulness is higher; therefore, PEOU affects PU in a positive manner. These two beliefs thus mediate the effects of other external variables on behavioural intention (Davis et al., 1989; Ashraf, 2014).

During the improvement of TAM, Davis et al. (1989) established that approaches shape aims. In other words, personal norms have little impact on behavioural purposes. Other studies also support the idea that subjective norms do explain the behavioural intentions for using information technologies (Keen & Taylor, 2004; Ha, 2012). Other studies such as Karahanna et al. (1999) showed the contrary – that subjective norms considerably alter intentions. This issue was investigated in detail by Karahanna et al. (1999), who found that the effect of personal customs on behavioural purpose is more intense for probable adopters than for users. Prejudiced norm theory can apply in this case as a portion of Saudis have historically opposed any form of modern progress due to what they see as an imposition of Western culture (Pickett, 2008).

Self-determination and motivation theories suggested extending the TAM to highlight the more hedonic aspects by measuring apparent enjoyment. These theories suggest that shoppers are motivated by intrinsic and extrinsic factors (Olsson, 2008). The desires to behave in a certain manner and to achieve specific goals are related to extrinsic inspirations. The view that satisfaction and contentment are achieved by performing the behaviour itself stem from more intrinsic motivations (Vallerand et al., 2008). Childers et al. (2001) support both extrinsic and intrinsic motivations. As an extrinsic motivation, the consumer may see online shopping as not only more convenient but also more fashionable and a symbol of technological advancement.

In the TAM, the PU construct captures the concept of extrinsic motivation (Venkatesh & Davis 2000). This means that time is saved and there is spending efficiency (Childers et

al., 2001). By contrast, PEOU refers to the procedure leading to the result and can be seen as an inherent influence; however, several authors dispute this idea (Perea et al., 2004), and argue that PEOU does not fully apprehend intrinsic drives. For instance, most consumers are happy with just how conveniently and easily the system works.

The TAM was verified in the operational setting through studies such as Kim (2012), Giovanis (2012), Bach, Čeljo and Zoroja (2016) and Al-Ghamdi (2012). These studies argued that the main factors in e-commerce adoption and acceptance are PEOU, PU, user's beliefs, and enjoyment. Chong (2012), for instance, stated that consumers' attitudes towards online shopping are positively affected by each of the predictors aforementioned. Using retail experiences in e-commerce and online shopping, these studies also examined the comparative effects of PEOU, PU, and user's beliefs. It was discovered that useful aspects (i.e., PEOU, PU) of online spending and hedonic aspects (e.g., enjoyment) play an equal role as predictors of online shopping behaviours. The final model showed that 67% of the attitude variance towards online shopping is determined by utilitarian motivation, whereas 64% of the attitude variance towards online shopping is determined by hedonic motivation (Asraar, 2015).

Tentative summary can therefore be drawn from the analysis of the TAM literature. First, from an online perspective, TAM identifies a significant portion of the discrepancy in online shopping approaches, including intent and behaviour. This builds on the impression that views of innovation largely determine acceptance and usage. Perceived risk and beliefs have an initial influence on new online spenders (Kim et al., 2012; Giovanis, 2012; Chong, 2012; Al-Ghamdi, 2012). These factors, however, cease to be important as consumers become more familiar with the Internet and online shopping, as the overall usage becomes more frequent.

A few studies investigated qualifications of key variables of the TAM in the online context (Kim et al., 2012; Giovanis, 2012; Chong, 2012; Al-Ghamdi, 2012; Wu, 2003). Figure 3.3 outlines the relationship between perceived usefulness, intention, and behaviour.

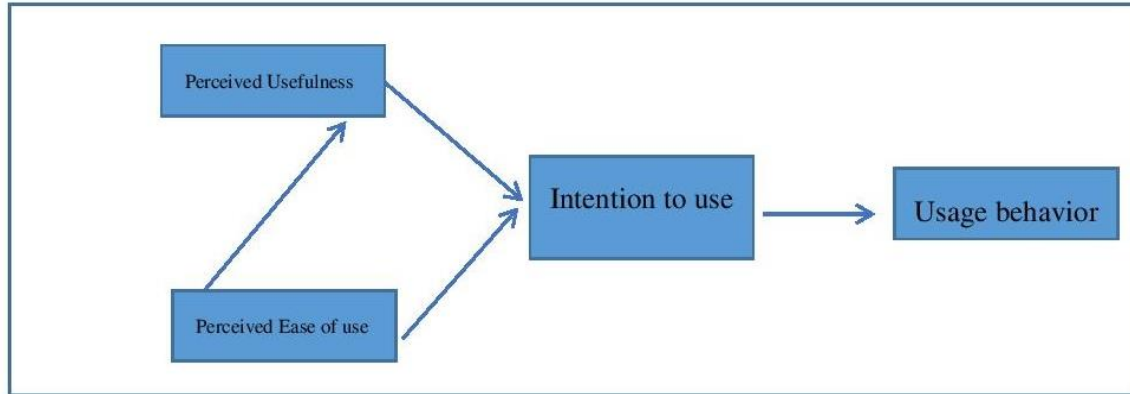

**Figure 3-3.** TAM, Source: Davis, F. (1989)

### 3.2.4 Unified Theory of Acceptance and Use of Technology

The Unified Theory of Acceptance and Use of Technology (UTAUT) is a unified model that was developed by Vankatesh et al. (2003), based on social cognitive theory with a combination of eight prominent IT acceptance research models. These theories include the TAM, TRA, Motivational Model (MM), combined Theory of Planned/Technology Acceptance Model (TPB-TAM), Social Cognitive Theory (SCT), Innovative Diffusion Theory (IDT), and the Model of PC Utilization. According to Vankatesh et al. (2003), the unified model was more effective than the other theories because it explained 70 percent of variation in usage and acceptance of technology. The UTAUT model uses four essential constructs that determine technology use and acceptance – effort expectance, performance expectancy, facilitating conditions, and social influence. These constructs were moderated by variables such as experience, gender, age, and voluntariness of use.

The model has been cited in a number of studies since its publication in 2003; however, few of these studies probe its constructs fully. Al-Awadhi and Morris (2008) conducted a study with the UTAUT framework to establish whether peer impact, exertion anticipation, and presentation expectation affected the behavioral intention of students. The study was conducted on 880 participants to investigate the acceptance of e-government services in Qatar. Another research study was conducted by Biemans et al. (2005) to investigate the behaviours of nurses towards the Medical Teleconferencing Application based on 37

selected empirical studies. The authors showed that effort expectation and performance expectancy are essential predictors of behaviour intention.

UTAUT was tested in different organizational and cultural contexts, including cross-cultural validation. Šumak et al. (2010) noted that communal effect is a powerful predictor of students' behaviour on the intent to use the Internet. The study identified students' behavior about their intention to use the Internet as an essential predictor of an e-learning system. In their research, Cheng et al. (2008) established that communal effect and presentation expectation provided the strongest indications of behavioral intention of use among Internet banking users in China. The researchers conducted another study establishing that social influence and performance expectancy are essential predictors of behavioural intention of users of Internet banking services. Fang et al. (2016) established that effort expectation, performance expectation, and communal impact are critical predictors of intention of use by managers when sharing knowledge about the Web 2.0.

Maldonado et al. (2009) conducted a study in Peru with 240 participants from secondary school to investigate the acceptance of e-learning technology. They found that social influence plays a role in predicting behavioural intention, and that behavioural intention affects the behaviour to predict use. Bhatti (2015) also conducted research exploring the acceptance of mobile banking and found that exertion expectation, presentation expectancy, and communal effect are essential predictors of behavioural intention.

In the telecommunication industry, Wu (2003) investigated the acceptance of 3G services in Taiwan and found performance expectancy and social influence to be predictors of behavioural intention. Interestingly, the authors also found performance expectancy, effort expectation, social influence and facilitating conditions to be predictors of use behaviour. He and Lu (2007) proposed that social influence and presentation expectation are essential analysts of behavioural intention of use of consumers. In mobile advertising, they claim, behavioural intention and facilitating conditions play a significant role in predicting behavioural use. Cheng et al. (2008) investigated Internet banking acceptance, and revealed that communal impact and presentation expectation influence behavioural intention of use. Other researchers contradicted the four constructs of UTAUT in predicting use and

## Chapter Three. Literature Review

intention behaviours. Chen and Li (2006) conducted a study establishing that exertion expectation, presentation expectation, easing situations, and communal effect have invariant scores. Thus, the researchers called for caution when interpreting the UTAUT model. Heerink et al. (2009) found that exertion expectation, presentation expectation, and communal impact have an insignificant role in predicting behavioural intention of use. Heerink et al. (2009) conducted a study to establish acceptance of a screen agent and robot interface by elderly users. Šumak et al. (2010) established that effort expectancy and performance expectancy have low power in predicting the behavioural intention of use. In a similar study, Cheng et al. (2008) found that effort expectancy plays no role in predicting behavioural intention. He and Lu (2007), Cheng et al. (2008) and Wu (2003) agree that effort expectancy does not predict behavioural intention to use. Maldonado et al. (2009) conducted research to establish the motivational role of adopting e-learning technology. They found that facilitating conditions do not impact use behaviour among users. Cheng et al. (2008) said that intention to use Internet banking is not affected by effort expectancy. They focused on customers' use of Internet banking to establish the role of UTAUT constructs in intention to use behaviours. Schaupp and Carter (2009) conducted research to examine tax payers' acceptance of e-filing. The study showed that effort expectancy does not affect behavioural intention of use. Therefore, inconsistencies in the studies on the UTAUT model showed inconclusive relationships with the model.

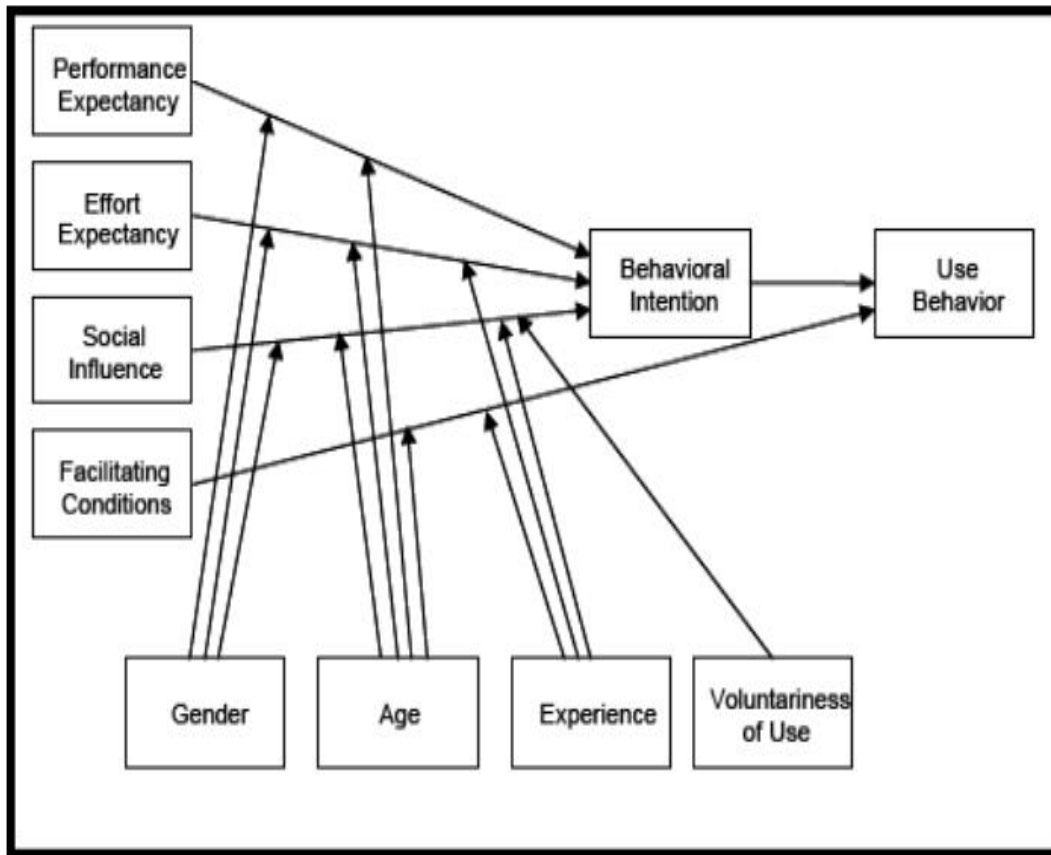

Figure 3-4. UTAUT, Source: Venkatesh et al., 2003

Table 3.1 reflects the development of OSAM over time. It started in the form of the TRA, which holds that an individual's behavioural intention depends on their attitudes; however, it was found that a person's real behaviour is not always influenced by the person's intentions. Thus, as discussed in Section 3.2.2, Ajzen (1985) introduced the TPB by coming up with another factor referred to as 'perceived behavioural control', which distinguishes the TPB from the TRA. The TAM was developed, and the components that affect and determined it are perceived usefulness, perceived ease, and behavioural intentions. The last stage of development is OSAM, where the focus is on consumer's satisfaction.

**Table 3-1.** Summary of history of OSAM

Study	Subject
Fishbein (1975)	Theory of Reasoned Action (TRA)
Ajzen (1985)	Theory of Planned Behaviour (TPB)
Davis (1989)	Technology Acceptance Model (TAM)
Venkatesh et al. (2003)	Unified Theory of Acceptance and Use of Technology (UTAUT)
Zhou et al. (2007)	Online Shopping Acceptance Model

### **3.3 Online Shopping Acceptance Model**

The TRA (Ajzen & Fishbein 1980), TAM, and TPB (Ajzen, 1991) have been used widely by scholars to provide a detailed explanation and forecast the behaviour of several users while shopping online (Pavlou, 2003). However, the development of OSAM was possible through the synthesis of some of the factors that affect online shopping acceptance to present a general consumer view of online shopping (Wolfenbarger & Gilly, 2001). The OSAM considers specific characteristics in the acceptance of online shopping, which emerged from its development with the TAM (Wu & Ke, 2016) Table 3.2 outlines the nature of several similar studies in the past and their outcomes in terms of TAM.



**Table 3-2.** Summary of the factors affecting online shopping intention

Major Factor	Factor Type	References	Survey Finding
Social Media		Kim et al., 2012; Mikalef et al., 2012; Saleh, 2016; Wally & Koshy, 2014; Weisberg et al., 2011; Pöyryet, 2012; Pöyry et al., 2012; Chin et al., 2009; Ramlugun & Jugurnauth, 2014; Koshy, 2013	Social media has a major impact on a brand of a product. It can make or break a brand as well as revive classical brands.
Demographics	Gender	Ansary & Roushdy, 2013; Doolin et al., 2005; Fan & Miao, 2012; Thamizhvanan & Xavier, 2013; McElroy et al., 2012; Chiu et al., 2014; Al-Magrabi, 2009	Some studies found that male consumers make more online purchases and spend more money online than females. On the other hand, females perceive greater risks toward online shopping; however, females are more attracted to websites that look attractive as compared to males who care more if a product is available or not.
	Age	Cowart & Goldsmith, 2007; Ha, 2012; Stafford et al., 2004; Chiu et al., 2014; Joines et al., 2003; Agrwal, 2014; Sulaiman et al., 2008; El-Ansary & Roushdy, 2013; Brown et al., 2007; Doolin et al., 2005; Fan & Miao, 2012; Haque et al., 2006; Thamizhvanan & Xavier, 2013; Thaichon, 2017	Different findings on the relationship between age and online shopping intention.
	Education	El-Ansary & Roushdy, 2013; Cho, 2004; Koyuncu & Lien, 2013; Liao & Cheung, 2001; Punj, 2011; Saprikis, 2013; Wang et al., 2012; Park, 2002; Van Slyke et al., 2002; Alhassan, 2011; Brosdahl & Almousa, 2013	Different education levels affect online shopping from non-related to a positive related.
	Products characteristics	Bruwer et al., 2011; Liao & Cheung, 2001; Amaro & Duarte, 2013; Koo et al., 2008; County, 2014; Zhou, 2004	Received insufficient attention in the extant research on online shopping
	Income	Haque et al., 2006; Serazio, 2013; Clemes et al., 2014; Al-Ghaith et al., 2010	Income is positively related to online shopping.

## Chapter Three. Literature Review

	Culture	Hawkins, 1997; Hofstede, 1991; Chau et al., 2002; Park & Jun, 2003; Wee & Ramachandra, 2000; Zaki, 2013; Sakarya & Soyer, 2013; Alsuwat, 2013; Ess, 2014; Rajput, 2012	Culture had an impact on intention to use Internet shopping in different ways. For example, cultural differences led to Internet usage, especially related to online shopping.
Online Shopping Experience		Lunn & Suman, 2002; Cho, 2004; Lohse et al., 2000; Lynch et al., 2001, Xia, 2002; Jusoh & Ling, 2012; Klaus & Maklan, 2012; Nambisan & Watt, 2011; Mikalef et al., 2011; Rouibah et al., 2016	National and regional culture had an impact on intention to use Internet shopping in different ways. For example, cultural differences are a major factor in what the Internet is used for, especially relating to online shopping.
Online Experience		Xia, 2001; Gentile et al., 2007. Verhoef et al., 2009; Bernard & Makienko, 2011; Mazaheri et al., 2014	There are mixed results on consumer experiences when it comes to online shopping.
Shopping motivation		Park et al., 2012; Chiu et al., 2014; Joines, 2003; Yu & Bastin, 2010; Childers et al., 2001; Chunling & Bastin, 2010; Holzwarth et al., 2006; Ling et al., 2011; Frang, 2016	Motivational factors play a key role in determining the time spent on product searching and online shopping. Experiential (hedonic) shoppers find more enjoyment in interactive environments than in pure text environments.
Shopping orientation		Mokhlis, 2009; Brown et al., 2007; Girard et al., 2003; Nichols et al., 2006; Joines et al., 2003; Mckinney, 2004; Rohm & Swaminathan, 2004; Li et al., 2007; Vijaysarathy, 2010; Dennis & Merrilees, 2009; Parikh, 2011; Vijayasathya & Jones, 2000; Park, 2002; Brown et al., 2007; Vijayasathya, 2010; Mosteller et al., 2014	Consumers' proclivity to purchase products online is not found to vary across different online shopping orientations.
Normative beliefs		Limayem et al., 2000; Vijayasathya, 2004; Gou et al., 2016; Zhou et al., 2007	The influence of friends, family and media recommendations on the tendency toward online shopping is mixed.

## Chapter Three. Literature Review

Innovativeness	An et al., 2016; Donthu & Garcia, 1999; Park & Jun, 2003; Limayem et al., 2000; Citrin et al., 2003; Sin et al., 2002.	Personal innovativeness has both direct and indirect effects on online shopping intention. The indirect effects are mediated by the shopper's attitude.
Attitude Towards	Mathwick & Rigdon, 2004; Yang et al., 2004; Rahman, 2016; Zendejdel et al., 2016	Studies investigated the influence of attitudes on the acceptance of online shopping, and found that attitudes are important in predicting online shopping intentions.

The aim of OSAM is to encourage potential consumers to shop online by showing how convenient it is for consumers to do so. The primary purpose is to predict and provide explanations regarding this type of shopping from different perspectives. These include the analysis of the perceived outcomes that cover both the potential risks and benefits that a consumer faces when online shopping, motivation, shopping intention, consumer demographics, satisfaction, and online experience – all of which converge to drive consumer buying (Wolfenbarger & Gilly, 2001). Furthermore, Figure 3.4 and Table 3.2 illustrate the depth and impact of OSAM in shaping consumer behaviour.

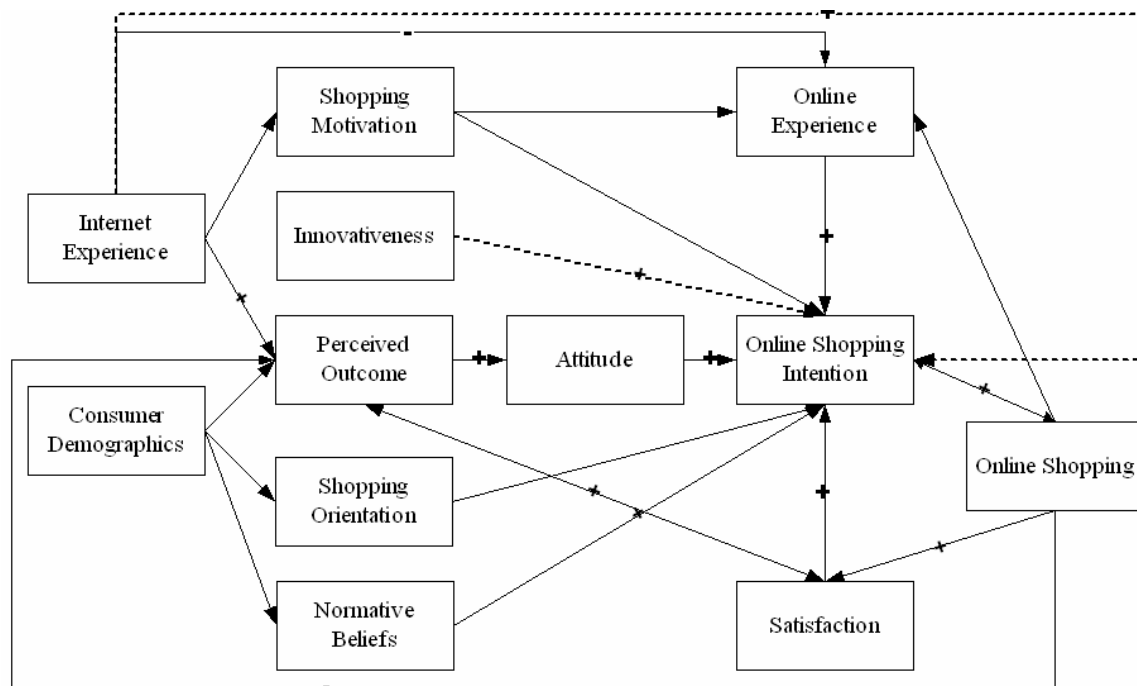

**Figure 3-4. OSAM, Source: Zhou et al., 2007**

Based on Figure 3.4, this study delineates the online shopping acceptance factors – consumer demographics, shopping motivation, shopping orientations, online shopping intention, online shopping experience, online experience, attitude, satisfaction, normative beliefs, perceived outcome and innovativeness.

### 3.3.1 Consumer Demographics

According to Limbu et al. (2012) and Liao and Keng (2013), the role of demographics is considerable in defining shopping trends. This claim was also made by Schindler et al. (2012). Research revealing the connection between demographics and online shopping has shown that people shopping on online platforms tend to be affluent, male and of a higher educational status (Liao & Keng, 2013; Utz et al., 2012). However, there is conflicting evidence as to whether this connection is valuable, as well as differing views as to whether

it will continue in future. For instance, one study reported no relationship between gender and online shopping (Fram & Grady, 1995).

In this study, demographics were examined as a significant factor that can impact online shopping intention in Saudi Arabia. Also, it is important to group consumers based on their characteristics, such as age, gender, income and education. Therefore, consumer demographics will moderate the relationship between the three independent variables – social media, shopping motivation and shopping orientation – and online shopping patterns.

### ***3.3.1.1 Gender***

The first of the consumer demographic factors is gender. Donthu and Garcia (1999) stated that there are few differences between online shoppers and non-shoppers and between genders; however, men were identified as making more purchases and spending more money on online transactions (El-Ansary & Roushdy, 2013; Doolin et al., 2005; Fan & Miao, 2012; Thamizhvanan & Xavier, 2013) in comparison to women (Susskind, 2004). Alreck and Settle (2002) argued that men's perception of online shopping is similar and at times more favourable than women's as men favour the availability of a product while women prefer to physically handle it before buying (Van Slyke et al., 2002).

McElroy et al. (2012) and Zhou et al. (2007) argued that hedonic values of the Internet derived from their respective studies are congruent with the results derived from other studies. These studies found that younger women emphasize hedonic motives more than their male counterparts and possess more powerful hedonic consumption drivers. Hedonic value measures the amount of joy or discomfort experienced by a consumer when doing various online shopping processes (Chiu et al., 2014).

In relation to the Saudi Arabian context, only one study has addressed gender in shopping online within the past decade. This authors demonstrated that female consumers are more interested in shopping than males (Al-Magrabi, 2009).

To address that gap, research needs to place more emphasis on gender to understand the effects of gender on online shopping intention in Saudi Arabia. Therefore, gender will moderate the relationship between the three independent variables – namely, social media, shopping motivation and shopping orientation – and online shopping patterns. This will allow us to test the following hypotheses: **H8**) gender is positively associated with online shopping intention (OSI) through shopping orientation (SO); **H12**) gender is positively associated with online shopping intention (OSI) through shopping motivation (M); and **H17**) gender is positively associated with online shopping intention (OSI) through social media (SM).

### *3.3.1.2 Age*

Like gender, age dictates distinctions between online customers. This was underscored in many studies where a correlation was found between customer's age and their likelihood of buying goods online (Stafford et al., 2004; Chiu et al., 2014). While research has shown that older individuals are more prone to buying online than younger ones (Coward & Goldsmith, 2007; Ha, 2012), other studies found that younger consumers (i.e., those under the age of 35) are more likely to shop online than older consumers (Joines et al., 2003). These different results can be explained by methodical reasons, such as different outcome variables and product types (Coward & Goldsmith, 2007).

In other studies, it was demonstrated that the millennial generation (i.e., those born between 1982 and 2002) enjoy the utilitarian and hedonic advantages of shopping online more than previous generations (Agrwal, 2014). This is due to the fact that millennials were largely exposed to Internet services, which have increased their awareness about products (Agrwal, 2014; Sulaiman et al., 2008). In addition, they are used to dealing with Internet-related issues.

According to Khalia (2014), who studies online shopping in Saudi Arabia, online shopping is becoming more popular among the younger generation, i.e., students and professionals

whose ages range from 18 to 29 years. Students usually prefer to buy goods from the original source and often they prefer to shop online.

On the other hand, a variety of studies have shown that there is a negative or even absence of relationship in the correlation (El-Ansary & Roushdy, 2013; Brown et al., 2007; Doolin et al., 2005; Fan & Miao, 2012; Haque et al., 2006; Thamizhvanan & Xavier, 2013). Moreover, Alsomali et al. (2009) found that younger Saudis were more likely to shop online than older ones. For example, Sulaiman et al. (2008) found that younger people are more likely to engage in online shopping due to their greater knowledge of computer technology, unlike the older generations who do not integrate technology into their life. This is not surprising since the younger generation tends to develop into Internet users more than the older generation due to their greater exposure to computers (Serazio, 2013).

In summary, this research will focus on age as an important factor that can affect online shopping in order to understand how age affects online shopping patterns in Saudi Arabia. Therefore, age will moderate the relationship between the three independent variables – social media, shopping motivation and shopping orientation – through the intention. This will answer several hypotheses: **H5)** Age is negatively associated with OSI through SO; **H9)** Age is negatively associated with OSI through M; and **H14)** Age is negatively associated with OSI through SM.

### ***3.3.1.3 Income***

The next factor in determining consumer online behaviour is income. Various studies show that most people who shop online have a higher income than those who shop in traditional stores. Most goods sold online are everyday products whose demand increases when there is an increase in the level of the consumer's income and purchasing power. For example, Haque et al. (2006) found that the attitudes of families with high monthly income tend to be positive towards online shopping compared to families with lower monthly income. Clear examples of these traditional goods include PC software and hardware, books, leisure and holiday travels, and music (Mahmood & Bagchi, 2004). Most online shoppers had

experience in online shopping, though young, and were usually of working-class age and thus with higher levels of income (Serazio, 2013).

Some studies have concluded that people with higher levels of income are more likely to shop online, while other studies suggest the opposite. This, however, applies to countries like Switzerland rather than Saudi Arabia (Haque et al., 2006). However, Al-Ghaith et al. (2010) found that income is the factor effect in consumer demographics best suited to online shopping in Saudi Arabia shopping because Saudi consumers have a high income level. People with more income are more likely to use the Internet for shopping.

This research will concentrate on income as a variable that may encourage consumers to develop online shopping intention in Saudi Arabia. Therefore, income will moderate the relationship between the three independent variables – social media, shopping motivation and shopping orientation – and online shopping patterns. This will test several hypotheses: **H7)** Income is positively associated with OSI through SO; **H11)** Income is positively associated with OSI through M; and **H16)** Income is positively associated with OSI through SM.

### ***3.3.1.4 Education***

There is a positive correlation between consumer's education and online shopping (Al-Ensary & Roushdy, 2013; Cho, 2004; Koyuncu & Lien, 2013; Liao & Cheung, 2001; Punj, 2011; Saprikis, 2013; Wang et al., 2012; Park, 2002; Van Slyke et al., 2002). Consumers who have higher levels of education tend to have a greater fluency with technology, and thus are more likely to engage in e-commerce activity more seamlessly. In fact, higher education creates higher amounts of discretionary income for people to spend online. In contrast, those with lower educational achievement levels demonstrate less comfort with technology as well as less discretionary income to spend online. Furthermore, in Saudi Arabia, there is a positive correlation between education and online shopping intention because consumers with a higher level of education are more likely to shop online (Brosdahl & Almousa, 2013).



This research will clarify the relationship between education and online shopping intention in Saudi Arabia. Therefore, education will moderate the relationship between the three independent variables – social media, shopping motivation and shopping orientation – and online shopping patterns. This will test several hypotheses: **H6)** Education is positively associated with OSI through SO; **H10)** Education is positively associated with OSI through M; and **H15)** Education is positively associated with OSI through SM.

### *3.3.1.5 Products Characteristics*

Product characteristics shape online shopping habits. Online sale channels can accommodate many kinds of products, although not all products are suitable for online sales. Bruwer et al. (2011) and County (2014) show that different products are more attractive to consumers in differing settings. For example, the appeal of a luxury car may seem greater in a television advertisement or a showroom than on a dealership website (Bruwer et al., 2011).

Consumer goods can be classified into three major categories: convenience goods, shopping goods, and specialty goods. Convenience goods are those which are bought frequently, immediately and with minimum shopping effort. Examples include groceries and newspapers. Shopping goods are generally durable, pricier than convenience goods, and their purchase is generally pre-planned. Examples are furniture and electronics. Specialty goods require special purchasing efforts, and the items possess some special features. The buyers are willing to spend a lot of time and money to buy them in contrast with shopping goods. Examples include jewelry and antiques (Kim et al., 2012).

Online marketing studies have shown that online shopping platforms are highly specialised. Studies in the past have concentrated mainly on similar goods (Liao & Cheung, 2001; County, 2014). A study undertaken by Aladwan (2013) focused on e-learning, while Dahlen and Lange (2009) explored the online selling of groceries. Bigne-Alcañiz et al. (2009) and Amaro and Duart (2013) evaluated online travel services. Al-Somali et al.

## Chapter Three. Literature Review

(2009) delved into online banking. In other words, the results of each study reflected a specific product or service market.

The level of consumer satisfaction regarding delivery, new products and post-delivery services differ according to the commodity type (Koo et al., 2008; County, 2014). Consumers were more satisfied with the delivery and post-delivery services of shopping and convenience goods. On the other hand, evaluation of the suitability of online buying was not effectively carried out by such classifications (Thirumalai & Sinha, 2005).

Additionally, the degree of acceptance of online shopping differs among customers particularly when they are purchasing dissimilar goods (Zhou, 2004). In some cases, customers link certain risks to certain products (Bhatnagar & Ghose, 2004). There is a difference in customer innovativeness and customer shopping orientation amid a variety of goods. Ultimately, the types of goods being sought influences whether consumers will turn to online or offline formats for their shopping.

### ***3.3.1.6 Culture***

The term ‘culture’ is complex and involves the knowledge, beliefs, arts, laws, ethics, customs, and many other abilities and habits that are obtained by an individual participating in a given society (Hawkins, 1997). It also refers to social factors such as reference groups, family, social roles, and social status (Wu, 2003).

In addition, ‘culture’ refers to a shared set of values that impact societal perceptions, attitudes, preferences, and responses. Hofstede’s cultural model (1991) develops five main cultural dimensions based on differences experienced within various countries and cultures across the world. The model includes notions of agency, gender, risk, orientation, and societal organization (Hofstede, 1991).

This model hinges on rather rigid interpretations of these notions. For instance, notions of gender may differ in various locales, while beliefs regarding individualism or collectivism are broad. In fact, these ideas do not seem to affect consumption habits, as those who are either more individualist or collectivist purchase products on Amazon equally among other

## Chapter Three. Literature Review

common outlets. In other words, political dispositions may have little impact on consumption habits.

In other studies, differences in cultures reflect differences in online shopping. For instance, an individualistic culture is realised within the US whereby inter-individual relationships are not strong. In these cultures, individuals utilize the Internet for personal purposes such as e-commerce and information searching (Chau et al., 2002; Park & Jun, 2003).

In a collectivist culture such as China, Saudi Arabia, Singapore, and Mexico, individuals place immense importance on communal relationships. Individuals within these cultures utilize the Internet for social communication and hobbies, such as sending/receiving e-mails, accessing/downloading software, and conducting work-related research (Wee & Ramachandra, 2000). On the other hand, Sakarya and Soyer (2013) examined the effects of different cultures in online shopping by comparing online shopping in Turkey and the United Kingdom. Their study found that online shopping behaviour significantly varies between these two cultures, and that culture has a significant differentiating effect on consumption value. Moreover, Alsuwat (2013) studied different cultures of online shopping between Saudi Arabia and New Zealand, and found that culture affects how individuals make decisions regarding buying online.

Another example of the relationship between a nation's population and culture is food delivery. It has been suggested that rapid development can be brought to the food delivery sector by facilitating the following:

- Adequate quantities of domestic products and services;
- Modifications in the lifestyles; and
- The promotion of online culture among the masses (Zaki, 2013).

The practice of both traditional and online food delivery is as familiar in Saudi Arabia as in other countries of the world, as families still rely on cooking and preparing food at home. Food preparation by housewives has its rituals, and families still prefer to eat homemade food, which provides an incentive for food retailers in the country. Hence, there are vital chances for a quick response to online food delivery in Saudi Arabia if it manages to get good advertising and marketing promotion. Moreover, a lack of public transportation and restrictions for women drivers also adds more value for this initiative (Zaki, 2013).

## Chapter Three. Literature Review

Cultures vary widely in this dimension, leading to the identification of different online shopping behaviours (Chau et al., 2002; Huang, 2003; Park & Jun 2003; Park et al., 2004). Some studies have found that there are relationships between resident areas and online shopping (Chau et al., 2002; Chen & Lee, 2005; Koyuncu & Lien, 2013; Doolin et al., 2005; Gong & Maddox, 2011; Van Slyke et al., 2010; Thamizhvanan & Xavier, 2013).

Sociocultural pressure has enhanced men's independence in their purchase decisions. Women, on the other hand, place more emphasis on personal contact and social relations in (Van Tubergen et al., 2016). Society has generally encouraged the development of affective relations among women through the incorporation of shared activities with adults of similar gender, as it enhances individual levels of interdependency in existent social relations (Rajput, 2012).

Gong (2009) identifies the sociocultural and technical factors that influence Saudi females' online shopping acceptance. The researchers present a semiotic diagnosis of the sociocultural e-commerce design requirement in their study, including human information functions (e.g., social world, pragmatics and semantics) and the IT platform (e.g., synthetics, empirics and physical world).

The research findings illuminate how sociological and cultural components drive female consumers to participate in online commerce platforms. In the next section, shopping motivation will be discussed, one of the factors of OSAM, and a factor inherited from the traditional (non-online) consumer.

Furthermore, a recent study comparing cultures between Saudi Arabia and the United States has concluded that an extraordinary doubt avoidance dimension would not accept any modification, and so opposed it. Therefore, this illustrates the substantial and major dissimilarities between customers living in the United States and in Saudi Arabia. According to the aforementioned survey, American consumers feel at less risk with online shopping generally and also less at risk in all six risk dimensions compared to Saudi Arabian consumers. Performance risk was rated as the highest by the US customers, followed by privacy risk, whereas consumers from Saudi Arabia felt the most risk financially in online shopping, followed by performance risk (Brosdahl & Almousa, 2013).

### **3.3.2 Shopping Motivation**

Online impulse buying has received some attention, and considerable academic studies have been conducted to examine online impulse buying behaviour (Park et al., 2012). Motivational factors have been found to be very important in improving online shopping by determining the amount of time people take to search and shop for products online (Chiu et al., 2014).

Likewise, motivational factors are among the factors seen in traditional studies regarding customers. Motivational factors explain how the shopping behaviour of customers affects the online environment (Joines, 2003). It has been observed that consumers in traditional retail stores shop in different ways. The difference in the method of shopping may be a result of their motivation to purchase goods online, which can be either utilitarian or hedonic (Yu & Bastin, 2010). Hedonic factors drive consumer actions toward goods and services that incite feelings of satisfaction and escapism (Childers et al., 2001), which tend to cost more. Furthermore, information related to that kind of content makes a hedonic purchase more probable, as one starts, for example, dreaming of an exotic destination rather than a local trip.

Chunling and Bastin (2010) discussed the hedonic factors leading to impulse consumption behaviour, and found that customers possessing hedonic behavioural characteristics tend to make quick decisions. Social media plays a role through advertising and viral promotion, which does influence compulsive buying. Arnold and Reynolds (2012) presented the novel idea that customers with hedonic attributes are attracted to online shopping as it makes their lifestyle more convenient. These customers can also be identified as experiential shoppers. As a result, the researchers concluded that the hedonic and utilitarian characteristics have a favourable influence on user intentions.

The extent of association offered by a website is a built-in feature in the support of instituting this association, since experiential shoppers frequently get extra pleasure in interactive surroundings compared to purely text backgrounds (Koo et al., 2008). Online shoppers who are beginners have a higher probability of using a website for experiential activities. Arguably, online shoppers who are experienced with using the Internet as well

## Chapter Three. Literature Review

as e-shopping mainly use the websites to quickly shop and not to spend time appreciating the site (Koo et al., 2008).

Chu (2008) investigated message framing and discovered that negative messages have more impact on consumers than positive ones (Chu, 2008). In other words, an online review, for example, that expresses a negative consumer experience influences consumer behaviour more than positive reviews. Other studies examined the impact of playful avatars, which refers to representations of humans in the virtual world, and perceived technology on online purchase intention (Alam et al., 2016). Moreover, online shoppers have to wait for the purchased goods to be delivered, which hinders their immediate satisfaction. This can also hinder spontaneous buying because it can pose an inconvenience (Francis & White, 2004). Additionally, the rise in consumers' expected expenditures in either returning or trading of goods may put off customers from purchasing goods online.

This research will focus on motivation as a significant factor that can affect online shopping intention in Saudi Arabia. Therefore, the motivation will affect online shopping intention and online shopping intention (OSI) through social media (SM).

This will test several hypotheses: **H9)** Age is negatively associated with OSI through M; **H10)** Education is positively associated with OSI through M; **H11)** Income is positively associated with OSI through M; **H12)** Gender is positively associated with OSI through M; and **H19)** M is positively associated with OSI through SM.

### **3.3.3 Shopping Orientations**

In the study of customer conduct, shopping orientations are known to stand out amongst the most proverbial ideas, which alludes to the general inclination of buyers around the demonstration of shopping (Mokhlis, 2009). This manner is shown in the shifting examples of item determination, data pursuit and elective assessment. Regarding the subject of shopping, the introductions are operationalized by a scope of mentality, presumption statements, and investment (Brown et al., 2007). Brown et al. (2007) suggest that the attitude of buyers would be influenced by Internet shopping, and that is why it is coherent

## Chapter Three. Literature Review

that purchasers have distinctive shopping introductions, and that the contrasts in prices are a significant motivation behind why they prefer Internet shopping. Al-Maghrabi and Dennis (2009) found that the Internet allows buyers to compare prices of an item from different retailers, and thus creates price competition. Thus, the Internet essentially diminishes the quest of cost for the buyers who are aware of the prices by giving them fast access to the data of the services or items (Girard et al., 2003). Regarding saving by shopping on the Internet, the creators recommend that the clients who are aware of the costs would attempt to discover the least expensive thing and decrease its cost by purchasing products on the Web.

Shopping orientations are identified through the general inclination of customers around the demonstration of shopping (Brown et al., 2007). They are *"conceptualized as a particular measurement of the way of life and operationalized on the premise of premiums, exercises, and assumption explanations. In fact, introductions have been contemplated for almost half a century in customary retailing and marketing writing"* (Nichols et al., 2006).

The fundamental attributes of Internet shopping include phenomenal comfort, the likelihood of being on time, shopping at desired places, compelling Internet searches, and helpful price comparisons (Schaupp & Carter, 2009; Al-Ghamdi et al., 2012). There is also a rehashed experimental confirmation demonstrating that purchasers have a tendency to be comfort-oriented (Donthu & Garcia, 1999; Li et al., 2007; Al-Ghamdi et al., 2012). Buyers value accommodation in shopping all the more as their recurrence of Internet shopping grows (Hidayat-ur-Rehman et al., 2016).

Parikh (2011) provides that along with demographic values such as age, gender, marital status and income, psychographic indicators are now also being employed to study consumer behaviour and market segmentation. Vijayasathy and Jones (2000) classify shoppers into four categories:

- Economic shoppers, who make their purchasing decision based on the price, quality and comparative value of the product;
- Personalizing shoppers, who tend to pay frequent visits to a shop and have personal-level interactions with sales staff;

## Chapter Three. Literature Review

- Ethical shoppers, who prefer to buy local products in order to support the country's economy (Shuman, 2013);
- Apathetic shoppers;
- In-home shoppers, who like to stay at home and order online;
- Economic shoppers, who look around for the best deal and arrive at a decision once they have checked the prices;
- Mall shoppers, who like visiting malls;
- Personalized shoppers, who like to shop around places where they are familiar with the salespeople;
- Convenience shoppers, who shop wherever is most convenient for them; and
- Enthusiastic shoppers, who enjoy the ritual of shopping.

Retailers need to determine the customers' shopping patterns in order to make sure their sales increase, because the retail outlets and market competition are competitive. A plethora of studies have revealed that shopping orientations have a huge impact on customers' online shopping patterns.

Another study conducted in Saudi Arabia showed that online shopping is more convenient than shopping in physical stores. Since people are always busy and short on time, they would rather buy gifts for other people online than actually purchasing them in person.

This research will focus on shopping orientation as an important factor that can affect online shopping patterns in Saudi Arabia. Therefore, shopping orientation will affect online shopping intention. This study will test several hypotheses: **H1)** SO is positively associated with OSI; **H5)** Age is negatively associated with OSI through SO; **H6)** Education is positively associated with OSI through SO; **H7)** Income is positively associated with OSI through SO; and **H8)** Gender is positively associated with OSI through SO.

### **3.3.4 Online Shopping Intention**

Online shopping intention is the degree to which customers are willing to purchase a product or service, and it is a simple, objective and observable predictor of future



## Chapter Three. Literature Review

purchasing behaviour (Lin & Liang, 2011). In fact, most of the retail and consumer researchers have examined intention in online shopping.

The Internet is rapidly maturing and becoming of a great benefit to shopping because consumers support the view that the integrity of online vendors is highly necessary and a main factor in forming consumer's intention to buy via the Internet, where their trust is still very tenuous (Ho & Chen 2013).

The topic of e-shopping has been researched widely, and results show that consumers' conative values regarding **acceptance** of e-shopping can be measured by e-shopping intention (Van Slyke et al., 2002; Al-Maghrabi & Dennis, 2011). It also can measure beliefs related to a consumer's intention to terminate an online deal before departure (Cho, 2004).

In Al-Maghrabi and Dennis's study, quite a lot of dimensions associated with e-shopping intention are independently measured and incorporated into a scalar intention, normally through factor assessment. In a survey conducted in Saudi Arabia, the researchers found that there is 65% growth in the trend of online shopping. The chief and foremost causes of online shopping continuance intention are pleasure, particular values and perceived practicality (Al-Maghrabi & Dennis, 2011). Moreover, Al-Ghamdi (2011) found that the presence of both physical and online shops and a government-backed e-commerce system are the major instigating factors for the trend of online shopping in Saudi Arabia.

On the other hand, Online shopping intention can be seen as any intention by consumers to purchase online goods. Online shopping can be seen through various factors such as possibility, expectations and probability. Some studies have played a great role in examining interaction between short- and long-term intentions to evaluate online shopping patterns (Choi & Geistfeld, 2004).

This research will focus on shopping intention as a significant factor that can affect online shopping in Saudi Arabia. Therefore, if shopping intention affects online shopping, that will answer part of the following hypotheses: **H1)** SO is positively associated with OSI; **H2)** M is positively associated with OSI; **H3)** OSI is positively associated OS; **H4)** OE is positively related to OSI; **H5)** Age is negatively associated with OSI through SO; **H6)** Education is positively associated with OSI through SO; **H7)** Income is positively

associated with OSI through SO; **H8**) Gender is positively associated with OSI through SO; **H9**) Age is negatively associated with OSI through M; **H10**) Education is positively associated with OSI through M; **H11**) Income is positively associated with OSI through M; **H12**) Gender is positively associated with OSI through M; **H13**) SM is positively associated with OSI; **H14**) Age is negatively associated with OSI through SM; **H15**) Education is positively associated with OSI through SM; **H16**) Income is positively associated with OSI through SM; **H17**) Gender is positively associated with OSI through SM; **H18**) SM is positively associated with OS through OSI; and **H19**) M is positively associated with OSI through SM.

### **3.3.5 Online Shopping Experience**

Online shopping can be defined as shopping processes that are conducted through the Internet although the system also uses other means such as mail to deliver the products. Consumers with in-home shopping experience are likely to purchase goods online. Most consumers who inquire about products by telephone are more likely to adopt e-shopping (Eastin, 2004). It has been observed that the use of mail or telephone in purchasing goods is closely related to online shopping (Lunn & Suman, 2002). In addition, the use of catalogues in shopping greatly influences consumers to adopt e-shopping (Lohseet et al., 2000).

The novelty of online shopping lies in the ability to browse online portals before and after shopping. Although online shopping begins with browsing, this does not guarantee a transaction, as customers may change their mind. Cho (2004) reported that only one out of four online shoppers makes a transaction. Moreover, Huang (2003) referred to the influence of product category and consumers' emotional connection to online shopping on browsing and transactions. Lynch et al. (2001), Xia (2002) and Huang (2003) discussed the role of the portal visitor's experience while browsing, which leads to the decision on whether to complete a transaction or abandon the visit.

A positive relationship exists between the probability of consumers to shop online and their experience with purchasing goods online. If experienced consumers are content with services and goods when they shop online, their probability of shopping more online is increased (Jusoh & Ling, 2012). Their shopping frequency will also increase (Klaus & Maklan, 2012). These consumers are less likely to terminate an intended online deal (Cho, 2004).

Subsequently, e-shoppers were found to be more likely to shop without going into a physical store, especially when buying goods from TV or a catalogue (Kaufman & Lindquist, 2002). It was also found that people with past experience in Internet shopping can easily adapt to buying goods online (Shim et al., 2001). In cases where a consumer has had a negative past experience regarding online shopping, the probability of such a consumer shopping online is minimal (Mikalef et al., 2012).

Following the model of online shopping acceptance, online experience is the least important factor of OSAM, which will be discussed in the next section and will also define the influence on the consumers of all the activities involved in online shopping (Zhou et al., 2007).

This research will highlight online shopping experience as a significant factor that can affect the online shopping intention in Saudi Arabia. Therefore, the online shopping experience will affect online shopping intention, and the online shopping experience and online shopping intention are moderated by online shopping, which will answer hypothesis **H4**: OE is positively related to OSI.

### **3.3.6 Online Experience**

According to Xia (2001), feelings are linked to a customer's understanding of their beliefs, given diverse online intentions. When a consumer is goal-oriented, he or she will take minimal time in browsing and processing such information, compared to those who browse for enjoyment. This can be interpreted as a positive effect. Online experiences are highly individualised, and the indulgence level varies from being rational to sensorial, spiritual,

emotional or physical (Gentile et al., 2007). The experience is also affected by factors that may be manageable or non-manageable for retailers. This includes the complete decision-making process, from searching to the post-purchase experience, in addition to various channels of purchase (Verhoef et al., 2009).

Mazaheri et al. (2014) conducted a study examining the effects of emotions on consumers' willingness and loyalty to purchase goods online in South America, North America, and Western Europe. It was discovered that positive emotions encouraged the manipulation of consumers in South America and Western Europe but not in North America. This research was undertaken in twelve countries from the three above-mentioned regions. Due to past experience of the North American population with online media, manipulation their emotions could not persuade them to buy CD players. From a product point of view, low-touch, harmonised goods may be less subject to the manipulation of the positive influence of the shopping experience than high-touch, experiential goods.

The diverse effects of the online shopping experience may perhaps be accredited to dissimilar things selected to assess it. According to Mathwick and Rigdon (2004), a positive online shopping experience improves customers' attitude towards online sellers and the types of goods being offered.

This research will highlight online experience as a significant factor that can affect online shopping intention in Saudi Arabia. Therefore, if online experience affects online shopping intention, that will answer two hypotheses: **H3)** OSI is positively associated with OS; and **H18)** SM is positively associated with OS through OSI.

### **3.3.7 Normative Beliefs**

“The influential interactive beliefs of a special group of referent individuals or sets such as family and friends” are called ‘normative beliefs’ (Ajzen, 1991). The subjective norm is, therefore, dependent on referent others’ (e.g., family, friends) perspectives of online shopping and how it drives the customer to agree with those beliefs (Ajzen, 1991 & Leo;

Vijayasathy, 2004). The theory of planned behaviour suggests this effect of normative beliefs on behavioural intentions.

However, there are no conclusive outcomes about the influence of friends. A study on online shopping intentions revealed that media influence ranks highest, followed by family influence, while the influence of friends was found to be insignificant (Limayem et al., 2000).

The category of online textbook purchases, however, was found to be affected by friends' recommendations (Zhou et al., 2007). This study suggests that referent influence is prone to the multiple categories of products.

### **3.3.8 Innovativeness**

Innovativeness is a measure of the speed with which individuals embrace new innovations and to what degree they accept them (Rogers, 1995; Agarwal et al., 2008).

Inconclusive findings were obtained regarding innovativeness. A portion of the research showed that having innovative behaviour had a positive direct influence on the acceptance of Internet shopping intention (Thakur & Srivastava, 2015).

The negative effect of innovativeness on online shopping intention was supported by several researchers (Donthu & Garcia, 1999; Park & Jun, 2003; Limayem et al., 2000; Citrin et al., 2003; Sin et al., 2002).

### **3.3.9 Perceived Outcome**

The perceived outcome suggested by Zhou et al. (2007) concerns both the perceived risks and benefits of online shopping. Perceived outcomes are comprised of all the possible outcomes (positive or negative) of a specific behaviour (Limayem et al., 2000). Hsu's study can also be termed as a cognitive behavioural belief analogous to the subjective probability that the behaviour will produce a given outcome (Hsu et al., 2014).

It is important, however, to also understand the different perceived risks in relation to different product categories: digital (e.g., music) and non-digital (e.g., apparel) (Park et al., 2004; Pires et al., 2004; Dillon et al., 2014). It was observed that perceived risk depends on many demographic factors, such as culture (Park et al., 2004), gender (Zhou et al., 2007), age (Zhou et al., 2007), Internet experience (Zhou et al., 2007), and product type (Pires et al., 2004). The choice of online shopping is made by customers based on the indirect probability of achieving a desired outcome; this theory was suggested in the TPB (Ajzen, 1991).

### **3.3.10 Satisfaction**

Satisfaction is a feeling that customers experience about their past online shopping encounters (Bhattacharjee, 2012). Satisfaction plays an important role in confirming consumer expectations based on their experience and also the imagined utility of an information system (Chang et al., 2009).

Marketing strategy is consequently affected by customer satisfaction. Generally, consumer satisfaction is said to have a positive effect on online shopping intentions. It simultaneously helps to retain the old customer base. Therefore, customer satisfaction has rightly become the top priority of companies across the world (Anisimova, 2013). The hallmarks of good customer service include responding quickly to customer queries and resolving customer complaints (Breazeale, 2009). To have a thorough grasp on factors affecting online consumer satisfaction is highly important for online retailers (McKinney et al., 2004). OSAM incorporates satisfaction as an extension in order to perceive the long-term continuance of online shopping. Satisfaction has also been described as an attitude factor that influences consumers' behavioural intention (Devaraj et al., 2002). As opposed to a consumer's pre-acceptance attitude, satisfaction is a post-acceptance attitude formed during various stages of online shopping.

### **3.3.11 Attitude Towards**

The focus of e-commerce has recently shifted towards consumers' attitudes and behaviour towards online shopping, as proposed by Chen (2009). This is because a consumer's perspective about a specific product is the most important precursor of their preferences towards products and services, including food (Voon et al., 2011). Hence, a better understanding of consumer attitude will allow us to understand individuals' preferences and behaviours.

Voon et al. (2011) described attitudes as an individual psychological feature, a representation of an individual's promptness to act or react in a particular way. Another definition is offered by Asiegbu et al. (2012) – namely, that attitude is a mental and neural state of promptness, resulting in response to experiences and stimulating a directive or dynamic response from the individual regarding all objects and scenarios relating to the individual. Another way of describing attitude, according to Fishbein and Ajzen (1975) in Asiegbu et al. (2012), is that it is a built-in inclination to counter or act in an unfailingly favourable (i.e., like) or unfavourable (i.e., dislike) manner with regards to a given object/situation.

A simpler definition given by Khalil (2014) states that an attitude is an outlook or predisposition to react in a specific manner owing to both an individual's experience and temperament, and his responses are a combination of feelings (emotions), thoughts (beliefs) and actions (behaviours). This definition conforms to the theory of Gordon W. Wilson (2010), who suggested that the attitude-behaviour relationship is multidimensional as opposed to previous views of its unidimensionality. According to Allport (2014), attitude is an intricate mix of an individual's beliefs about an object, his emotions about it, and his inclination to act with respect to that object. Another view proposed by Rahman (2016) suggests that attitude is an individual's perception of a single concept, which can oscillate between the extremes (positive or negative) of the continuum. Attitudes form as a result of one's personal experiences and develop further by learning from experience, information from friends, salespersons, and the news media. Attitude is a mixture of all direct and indirect life experiences. In a nutshell, what consumers' think and feel about a

product or service is ultimately a measure of the extent to which they adopt the product or service.

Many past studies on the influence of attitude in online shopping have revealed that attitude is indeed a very crucial factor in calculating online shopping intentions or behaviours. Zendehdel et al. (2016) proved that online shopping intentions were relatively high and supported by positive attitude towards online shopping among postgraduate students in Malaysia. Similarly, Jarvenpaa et al. (2000) showed that high consumers' intention to shop online (or readiness to buy from an Internet shop) was indicative of a positive attitude associated with online buying and thus ultimately affects customers' decision-making and purchasing actions.

Attitude towards online shopping has been identified as a very important antecedent of customers' online shopping intentions and behaviours in the works of George (2002) and Yang et al. (2004). Keeping in view the findings of the research, Wu (2003) proposed that since attitude is known to affect customers' online purchasing tendencies, a customer base with a relatively high positive attitude towards Internet buying should be the target market.

### **3.4 Social Media**

A person can be influenced socially by three main factors: media, relatives, and friends (Schivinski & Dabrowski, 2016). This applies mainly in the context of commerce (Chen, 2014). These factors were identified through research aiming to assess online shopping intentions. The leading component that affects online shopping is media, followed by family (Limayem et al., 2000). However, Hawang (2005) discovered that friends have little influence on the consumer's intention to purchase goods online. Nevertheless, trust in online shopping is influenced by media, family and friends (Hwang, 2005). Thus, people independently decided whether to purchase, but were influenced by others as to which sites to buy from; however, studies have shown that mass media, such as the popular press and news reports, greatly influences e-commerce needs, because the mass media influences individuals' behaviours (Bhattacharjee, 2012).



## Chapter Three. Literature Review

It is crucial that social media be made accessible to consumers. This enables people to browse information about products, which will exert a positive influence on their purchase intention. Therefore, the number of purchases can be increased by including information about the products on social media such as Facebook, which is the most popular type of social media in countries worldwide, with the exception of a few like China and North Korea. This is a very efficient strategy for companies. Social media pages act as a source of information. Consumers often compare the information about a product from various websites in order to make the best choice (Pöyryet, 2012). A consumer is likely to benefit from the relationship that exists between search questions and social media. This can be seen in Facebook, where Facebook Search has integrated a Search engine allowing users to search for newsfeeds while displaying consumer ads on the side.

It was found that social media plays a key role in marketing (Bough et al., 2010). This is because social media networks are used as advertising platforms, which increase product exposure to a large consumer base. Social media platforms improve brand recognition. Some companies market their products with correlated information on all platforms. This can act as a motivation for companies that have been reluctant to develop strategies to increase their online sales, because most of these consumers, after browsing for information on a product, share the information with family and friends. Hence, there is a higher probability of increased sales (Milkalef et al., 2012).

Studies focusing on the hedonic and utilitarian motivations context of adoption from the TAM were conducted primarily to understand consumer behaviour in company-hosted social media environments (Pöyry et al., 2012). Chin et al. (2009) suggested that the influence of social media in Malaysia in terms of positive and negative messages creates a moderating relationship between trust in the Internet and willingness to provide personal information online.

Ramlugun and Jugurnauth (2014) discussed the role of ease and value-based purchasing on social media platforms compared to traditional channels in relation to attracting customers. These researchers recommended that online social platforms for businesses

## Chapter Three. Literature Review

should provide quick, easy access to company offerings, as well as detailed information about their benefits.

Research into the users of social media in Saudi Arabia and the UAE with an Internet penetration of 91% in 2016 discovered that a high percentage of people spend too much time on Facebook. Fifty-two percent of the respondents in the UAE said that they could not live without Facebook. Most of them confess that logging into a social media platform like Facebook is the first thing they do on the Internet every day. Further, one-third of respondents said that they access social media in their place of work (Koshy, 2013).

Online shopping intention is one of the most frequently applied constructs developed on the basis of the OSAM and applied in various settings. Online shopping is influenced by a variety of factors and contingencies, including age, income, product type, information availability, quality and discount level. Ahmed and Bahaziq (2013) found that many individuals value the time spent shopping with friends or family members.

In addition, most individuals enjoy partaking in social activities while shopping. According to Wolfenbarger and Gilly (2001), the emergence of virtual communities caused a shift in the social benefits derived from the identification of more friends and relatives utilising the Internet. Internet shoppers enhance the information sharing process with online shoppers who have similar interests. Thus, the online experience developed into the main subject of conversations that provide high levels of pleasure to Internet shoppers.

The purchasing process is initiated when a consumer begins browsing for products, which may influence the purchase of these products (Milkalef et al., 2012). Milkalef et al. (2012) identified that purchasing incorporates a series of steps that includes browsing and purchasing. The relationship of social and online intentions to consumer demographics has been noted within the literature, and it has a strong influence upon inclusion within the online shopping process.

This research will highlight social media as a significant factor that can affect online shopping through online shopping intention in Saudi Arabia. Therefore, social media will affect online shopping intention and online shopping. This will test several hypotheses: **H13)** SM is positively associated with OSI; **H14)** Age is negatively associated with OSI

through SM; **H15**) Education is positively associated with OSI through SM; **H16**) Income is positively associated with OSI through SM; **H17**) Gender is positively associated with OSI through SM; **H18**) SM is positively associated with OS through OSI; and **H19**) M is positively associated with OSI through SM.

### **3.5 Why Is OSAM the Most Relevant for This Research?**

The main model considered for this study is OSAM because it captures some of the characteristics specific to shopping online. The development of the OSAM has involved the incorporation of consumer factors generated from marketing theories and traditional retail. These factors are inherited from the TAM, but the OSAM re-examines and aligns them specifically with online shopping, which is the main subject of this study. This re-examination involves developing a model that can be used to predict and explain consumer acceptance of online shopping, which includes seeking information on the product and its purchase (Fang et al., 2016).

Furthermore, the TAM was widely used in studies in an online shopping setting; however, it does not involve activities that are specifically related to shopping online, such as virtual browsing. The primary reason for developing the TAM was to explain and predict computer usage behaviour among the Internet community (Moon & Kim, 2001). As a result, even though the TAM is a more established theory, it is not specific to online shopping; thus, it will not be used in this study. There is an increased online experience and therefore consumers largely rely on their own shopping experiences. This study does not use the TAM for the following reasons:

1) TAM was designed to explain the acceptance and use of technology but does not clearly relate technology to the opposing choices from which consumers can choose; therefore, TAM handles the Internet separately from the offline channel. PU refers to the comparative advantages of Internet use, e.g., how Internet shopping enhances effectiveness and saves time, but it does not address the transactions that have to be made by consumers.

## Chapter Three. Literature Review

2) The TAM places more focus on the perceptions of technological application, thus covering the role of retailers (Zhou et al., 2007). It makes the assumption that e-retailers do not differ in their performance when predicting online channel adoption. The PU concept is extensive, i.e., it refers to utility but does not differentiate saving time and effort from improving outcome quality. Therefore, it is unclear whether consumers see the Internet as a useful tool due to its superiority and variety of products, lower prices, time savings or better service.

3) The relationship between intention and behavior is accepted both in the social sciences and in the field of information systems (IS). However, there are three challenges to characterizing this relationship. First, theories on the movement from intention to behavior take behavior as the destination; the models do not account for the fact that a behavior may sometimes be considered as a means to other objectives. For instance, the goal of software-purchasing behavior is to deal with information efficiently rather than to own the software. The TAM model incorporates the merits of use beyond acquisition.

4) In addition, the problems with TAM are not entirely peculiar to it but inhere as well in the TRA and TPB, which should bring pause to accepting any proposal suggesting that the TRA and TPB constitute panaceas. For purposes of organization, I maintain that the primary shortcomings of the TAM (and the TRA and TPB) reside in (a) two critical gaps in the framework, (b) neglect of the group, social, and cultural aspects of decision making, and (c) online shopping environments.

5) The gap between use and objective accomplishment is ignored in the TAM apart from the assumption of upstream in the TAM. Further, it is important for the TAM to clearly represent the end-state objective or goal for which technology is used, as discussed below. In addition, factors and events that occur between the development of an intention and the final action must be considered. The duration between intention and action can be of any length; during this time, various distracting or attracting events may arise, some of which may also be unpredictable.

Hence, we must account for instrumental and psychological implications, which may also call for the adjustment of a possibly ill-planned intention. Next, consumers often develop

## Chapter Three. Literature Review

a realisation of the attractions and deviations in the time before they act; they then seek other solutions to deal with any ambiguity that may arise. Consequently, consumers tend to take a step or acquire a technology that re-determines their viewpoint, and this is not only related to behaviour (Bagozzi & Yi, 2012).

6) The most important element lacking from TAM is the connection between consumers' reactions to using technology and their intentions. A wide range of influences is accepted by consumers when developing an intention for carrying out an action. The TAM and TRA discuss two influences, whereas the TPB determines three. Practically, these dimensions are assumed to be a result of various beliefs and considerations. Further, two factors call for attention. First, there is the probability of missing a convincing motivation toward an action based on an assumption (Bagozzi & Yi, 2012). For example, a person can recognize and even accept that PU or attitudes are favourable criteria for deciding to act, but have no desire to act and even explicitly decide not to act in the face of these reasons. In other words, PU and attitudes need not contain or constitute motives to act for any particular decision maker or specific situation. A second issue to consider is how multiple reasons for acting or not acting, which can be considerable in number, are reconciled and transformed into a decision or intention to act.

The internalisation process results from socialisation and psychological development, where individuals are subject to participation with respect to gender, family, ethnicity or similar and related group settings. It can also occur through groups in educational communities, training, adapting to instruction within some organisations and so on. A reference group is usually determined to be a mix of both ideas.

9) TAM identifies a process utilized in the study of online shopping environments. This process does not integrate the specific characteristics pertaining to online shopping. For instance, the online shopping environment aims at enticing more consumers to shop online, as opposed to being merely generic information systems. Therefore, this study integrates various consumer factors from traditional retailing and marketing theories to enhance effective development of the OSAM. Additionally, the factors inherited from the TAM incorporate regular re-examination from the online shopping context. OSAM has been

## Chapter Three. Literature Review

developed to enhance the prediction and explanation of consumer acceptance of online shopping. This was achieved by extending the belief-attitude-intention-behaviour relationship in the TAM through the integration of the following perspectives:

- Social media acts as a platform between consumer behaviour and shopping intention to account for repeated online shopping.
- The integration of consumer demographics and online shopping experience, and their direct or indirect effects on online shopping intentions.
- Perceived usefulness was replaced by perceived outcome to cover both the potential benefits and risks of online shopping.
- Three new factors were added as antecedents of online shopping intention. Two of them – namely, shopping orientation and shopping motivation (Childers et al., 2001) – were identified from traditional retailing and marketing literature, and the third – online experience – was derived from the results of empirical studies (Huang, 2003; Lynch et al., 2001; Xia, 2002).
- Satisfaction was a new mediating factor between behavior and shopping intention to account for repeated online shopping.

On other hand, this study found that integration across theories can be viewed in terms of the utility maximization theory of economics, in which the utility of an alternative is positively related with its benefits and negatively related to its costs. The evaluation, weighting, and way of combining benefits and costs may vary by individual, but each individual is assumed to balance the benefits of each alternative against its costs and to choose the one with the highest net benefits or utility. For example:

- (1) In the TRA, both attitudes and subjective norms can be positive with respect to the behavior (benefits) or negative (costs). For example, in Cho (2004), an inability to physically examine the goods and concerns over delivery and return can be viewed as liabilities or disadvantages of e-shopping, while the saving of effort it makes possible can be viewed as a benefit.

(2) Similarly, in the TPB, measures of perceived behavioral control (e.g., the site accessibility and transaction efficiency of Limayem et al., 2000) represent costs or benefits of adoption, depending on whether the measure is positively or negatively oriented, and whether a shopping alternative rates high or low on it. Cost measures can in some cases represent prohibitively high costs or outright constraints, and in other cases may fall on a continuum constituting gradually stronger disincentives to adopt. The converse is true for benefit measures.

(3) In the TAM, usefulness and ease of use are two categories of benefits (or, if negatively oriented, costs) which broadly construed can contain most or all of the constructs of the other theories. For example, a negative subjective norm can be viewed as reducing the ease of use of an alternative.

### **3.6 Limitations of the Online Shopping Acceptance Model**

The OSAM comprehensively covers most aspects of the online shopping experience and its relation to shopping intention, as compared to other models such as the TAM; however, the model has a few shortcomings worth noting.

The model fails to adequately tackle several important issues associated with consumer online shopping intentions. This is because some of the constituents of the model have not been researched adequately, thus creating a knowledge gap. For instance, product characteristics classified under consumer demographics (Ba et al., 2005) received insufficient attention, even though they are paramount in determining consumers' online shopping intentions. Most research conducted previously has concentrated on one or several products for simplicity or controllability of the study. This was the norm until a decade later, when researchers like Agwu and Murray (2015) examined the uptake of e-commerce.

Age is another factor important in determining shopping intention; yet, it too has been inadequately researched. Most researchers have concentrated on the effects of age on online shopping intention and ignored other important aspects that may influence a

consumer's online shopping intention, such as gender income and education. There is a need for more studies to include other aspects, such as whether people from different age groups shop for different purposes or if the effects of age on shopping intention will change with the growth of the Internet population (Zhou et al., 2007). Such studies will fill the information gaps and increase the acceptability and usability of the model. Apart from the inadequate research in some areas of the model, the OSAM provides a holistic view of the consumer online shopping experience, and most of the above-mentioned shortcomings can be overcome if researchers utilise the model to cover them more comprehensively.

Also, the OSAM does not focus on social media as an active factor that can strongly influence the acceptance of online shopping. Thus, there is a need for more studies to narrow their focus on social media channels such as Facebook, Instagram and Twitter.

### **3.7 Summary of Hypotheses**

Based on the literature review, a conceptual model has been designed to study the effects of online shopping intention, social media use and shopping motivation. The relationships between the predictors (independent variables) and dependent variables will be analysed in Table 3.3.



Table 3-3. **The Research Hypotheses** retrieved from Mikalef et al., 2012; Zhou et al., 2007.

<b>H1</b>
Shopping orientation (SO) is positively associated with online shopping intention (OSI).
<b>H2</b>
Motivation (M) is positively associated with online shopping intention (OSI).
<b>H3</b>
Online shopping intention (OSI) is positively associated with online shopping (OS).
<b>H4</b>
Online shopping experience (OE) is positively associated with online shopping intention (OSI).
<b>H5</b>
Age is negatively associated with online shopping intention (OSI) through shopping orientation (SO).
<b>H6</b>
Education is positively associated with online shopping intention (OSI) through shopping orientation (SO).
<b>H7</b>
Income is positively associated with online shopping intention (OSI) through shopping orientation (SO).
<b>H8</b>
Gender is positively associated with online shopping intention (OSI) through shopping orientation (SO).
<b>H9</b>
Age is negatively associated with online shopping intention (OSI) through shopping motivation (M).
<b>H10</b>

## Chapter Three. Literature Review

Education is positively associated with online shopping intention (OSI) through shopping motivation (M).
<b>H11</b>
Income is positively associated with online shopping intention (OSI) through shopping motivation (M).
<b>H12</b>
Gender is positively associated with online shopping intention (OSI) through shopping motivation (M).
<b>H13</b>
Social media (SM) is positively associated with online shopping intention (OSI).
<b>H14</b>
Age is negatively associated with online shopping intention (OSI) through social media (SM).
<b>H15</b>
Education is positively associated with online shopping intention (OSI) through social media (SM).
<b>H16</b>
Income is positively associated with online shopping intention (OSI) through social media (SM).
<b>H17</b>
Gender is positively associated with online shopping intention (OSI) through social media (SM).
<b>H18</b>
Social media is positively associated with online shopping (OS) through online shopping intention (OSI).
<b>H19</b>
Shopping motivation (M) is positively associated with online shopping intention (OSI) through social media (SM).

### **3.8 Summary**

This chapter reviewed studies on the development of the Online Shopping Acceptance Model (OSAM) from The Unified Theory of Acceptance and Use of Technology (UTAUT), The Technology Acceptance Model (TAM), which is also developed from the Theory of Reasoned Action (TRA) and Theory of Planned Behaviour (TPB). The theories survey the role of individuals' attitudes as well as subjective norms in determining behaviour in online shopping.

The OSAM was selected to examine the behaviour of online shoppers in Saudi Arabia and the factors that contribute to shoppers' behaviour of purchasing online. Demographic factors of the online shoppers are considered, such as gender, age, culture, education, and shopping orientation. These are all indicators of the acceptance or rejection of online shopping.

The chapter also adopts the use of social media as an additional factor that determines the use of online shopping. The components of the OSAM were analysed and studied individually in order to track their contribution to the acceptance/rejection or the nature of online shopping in Saudi Arabia. The next chapter discusses the methodological approach taken in achieving the aims of the study.

## **Chapter Four. METHODOLOGY AND RESEARCH PLAN**

### **4.1 Chapter Overview**

The previous chapter established the need for a framework which captures the factors that affect online consumers' perceptions of online shopping. The current chapter's aim is to present and discuss the methods of research adopted to satisfy the objectives of the research.

This chapter begins by explaining the three types of paradigms considered for this study: the positivist, the interpretive, and the critical social science paradigm. Additionally, the assumptions underlying these three paradigms are presented and discussed. The first section lays the framework for the positivist approach used in this study. Next, various types of research are explained, including exploratory, descriptive, and explanatory, along with the rationale of this study.

This chapter discusses the design and implementation of quantitative research. A survey and online questionnaire were employed as data collection tools. The chapter also offers a detailed explanation of the sampling issues encountered, the steps involved in carrying out the online survey, and how the survey was prepared for analysis.

### **4.2 Definition of Research**

Easterby-Smith et al. (2008) suggests that examining research philosophy helps clarify the choices available in research design. Consequently, it is important to select and identify the philosophy that best suits the study as it offers a firm foundation for the research (Coghlan & Brannick, 2014).

According to Pittaway (2006), paradigms must be defined and examined in scientific practice, because assumptions and philosophies are developed out of paradigms. Paradigms identify the framework within which the research is conducted.

### **4.3 Research Philosophy**

The philosophy used to design a study reflects the researcher's approach and the reasons for the development of knowledge based on its effects on the researcher's decision and how to carry out the study (Saunders et al., 2007). In addition, there are three reasons underscored by Easterby-Smith et al. (2004) that the individual carrying out the research should consider the underlying philosophy. First, the research philosophy elucidates the research design and its methods for collecting and interpreting the data required to answer the research questions. Second, it offers a direction for the research design that is appropriate and highlights the probable limitations of the design. Finally, it helps researchers produce new research designs or adapt designs to the constraints of the particular subject or knowledge structure.

The assumptions include ontological and epistemological assumptions. Ontological assumptions refer to the branch of metaphysics that seeks to assess the nature of existence (Pittaway, 2006). Ontological assumptions emphasise the nature of reality and develop an understanding of the construction and representation of reality in human consciousness (Pittaway, 2006). Epistemological assumptions stand for a branch of philosophy that studies the nature of knowledge by identifying its sources. Epistemological assumptions study the process whereby individuals create an understanding together with a conceptualization related to the world around them by developing assumptions about the aspects that constitute knowledge, together identifying its consequent construction and communication (Saunders et al., 2009).

Identification of the philosophical approach best suited for a research project depends on the association between the research questions and the philosophy underlying the thesis. Kura (2012) summarized three pertinent philosophies used in modern research – critical social science, interpretivism and positivism. In addition, Bryman (2012) specified that all philosophical approaches offer both positive and negative effects in different research

contexts. The following subsections explain the three options considered for this study and justify the selection made based on epistemology, ontology, axiology, and methodological beliefs.

### **4.4 Research Paradigm**

In accordance with Taylor et al. (2007), a *paradigm* is “a wide view or a view-of-something.” Furthermore, according Weaver and Olson (2006) how a paradigm is defined sheds light on how a study is affected and guided by a particular paradigm. The researchers point out that “paradigms are considered to be patterns of practices and beliefs that have control of inquiry in a discipline by giving lenses, processes and frames in a way which investigation is completed.” Hence, to clarify the inquiry structure of a researcher and choices of methods, paradigm exploration is discussed prior to any discussion about the choice of methodology.

According to Guba and Lincoln (1994), a paradigm is a set of beliefs, concepts, values, and methods, which deals with first or ultimate principles. A paradigm presents a worldview, the place of somebody within it, and its parts. Beliefs are termed as ‘basic’ in logic. Beliefs are accepted simply under the influence of faith, and there is no means of establishing their validity. Thus, philosophical debates cannot be resolved (Bryman, 2012).

#### **4.4.1 Positivism Paradigm**

The term *positivism* is a derivative of *positum*, a Latin word meaning ‘the passive version. Hence, positivism represents something which is set aside that offers facts that the researcher utilizes. Data represents an element which exists, and the task of the researcher is to gather and systemize data (Alevesson & Skoldberg, 2009). According to Tobin (2006), positivism is defined as a scientific method used to conduct study or research. This particular philosophy adds to realism as an element that is able to express an objective standpoint.

## Chapter Four. Methodology and Research Plan

Positivism is a traditional type of research. Kerlinger and Lee (1999) explain that positivism is based on the belief that research in the social sciences is carried out in the same way as research in the natural sciences. Positivistic research leads to predicting and controlling phenomena.

Myers (2013) argues that the positivist paradigm searches to test theory in order to understand the measured phenomena. Therefore, some researchers prefer a positivist approach because it highlights "*getting objective measures of 'hard facts' in the form of numbers*" (Neuman, 2006, p. 42).

### **4.4.2 Interpretivism Paradigm**

Researchers who engage in interpretive research make the assumption that access to reality, whether offered or constructed socially, is only by social construction. This includes shared meanings, consciousness, and language. Interpretivism incorporates an anti-positivist concept, where researchers identify reality as unstable and impossible to realize from an objective point of view (Creswell, 2013). The model of interpretivism covers two intellectual traditions – phenomenology and symbolic interactionism. Phenomenology represents the process incorporated in human thought that enables an understanding of the world (Bryman & Bell, 2011). Symbolic interactionism posits that humans are continually seeking interpretations of the social world by interpreting the actions of others. This enhances adjustment of the identified meaning pertaining to various incorporated actions.

Hermeneutics and phenomenology form the philosophical foundation of interpretive research. Generally, the study of interpretive issues obtains knowledge of phenomena through the meanings that individuals assign them, and methods of interpretive research are “aimed at generating context understanding of the information system, and the process where the influence of information system is context-influenced” (Walsham 1993, pp. 4-5). Interpretive studies do not predefine independent and dependent variables, but focus fully on the complexity of human sense-making as the situation arises (Kaplan & Maxwell, 1994). Walsham’s (1993) works are examples of the interpretive approach to qualitative

research. Klein and Myers' (1999) paper suggests a set of principles for conducting and evaluating interpretive research.

### **4.4.3 Critical-Social Science Paradigm**

A critical approach to research includes actionable research (Bhattacharjee, 2012), assuming that a complex phenomenon of social research is perhaps more appropriately tested by making observations on how the actions affect the population at the individual level. The corresponding ethnographic approach to research is directed towards building the necessary theory, which employs an inductive approach related to the data collected.

Critical study focuses on the contradictions, oppositions, and conflicts within a society that is contemporary and seeks to be emancipator. This approach is intended to help eliminate the causes of alienation and domination.

Ngwenyama and Lee's (1997) research, together with Hirschheim and Klein's (1994), provided an exemplary critical approach to qualitative research. Researchers who adopt a critical lens view social reality as constituted historically, generated and regenerated by individuals. Despite the fact that individuals have the ability to act in a conscious manner and change their socioeconomic circumstances, researchers in the category of critical research reveal that the ability to act is limited by several forms of political, cultural and social domination. Social critique is considered to be one major task of critical research, as the alienating and restrictive aspects of the status quo are revealed.

The critical social science paradigm has its own origins in critical theory. Horkheimer and Adorno (2002) are particularly credited for developing the paradigm of critical theory. He describes it as a paradigm that aims "to set free human beings from the conditions (circumstances) that make them slaves." It was established as a school of thought by five theoreticians – Herbert Marcuse, Max Horkheimer, Walter Benjamin, Theodor Adorno, and Erich Fromm – from the Frankfurt School in Germany. Drawing from the critical methods of Sigmund Freud and Karl Marx, the originators of critical theory focus mainly on ending social injustice. Researchers who use this paradigm today continue to aim at



transforming society by addressing inequalities, especially in relation to ethnicity, gender, and disability (Mackenzie & Knipe, 2006).

The purpose of this study is to investigate a causal relationship between the independent and dependent variables that affect the OSAM through social media in Saudi Arabia. Therefore, the rest of this chapter will focus on the positivist approach.

### **4.4.4 The Current Research**

This research was conducted from a positivist paradigm that contributes toward an improved understanding of the association between factors, which would identify relationships between online shopping and the corresponding factors affecting the use of social media. The current treatise considers a positivist view with regard to online consumers and the factors that play a role in the utilization of social media in online shopping; both the OSAM and TAM theoretically contribute towards the model chosen for this study.

Flick (2009) argued that the OSAM provides the outline that determines and summarizes the online shopping tendencies and aspects of consumer behaviour in conjunction with such factors as the available online infrastructure and the demographics of a given area. Furthermore, the effects of the OSAM were taken into consideration in this study. Hence, the study is considered to be an extension of previous research in this regard (Zhou et al., 2007), in addition to providing valuable input on the purchase trends of online buyers.

Table 4.1 provides a detailed summary of the objective-subjective debate as it relates to the positivist and interpretivist paradigms between the critical social sciences and the current study. This table also draws upon theories by Bryman (2012) and Kidd and Kral (2005). As illustrated in the table, the current study follows the positivist paradigm.

**Table 4-1.** Paradigm approach adapted from Bryman, 2012, Kidd & Kral, 2005

Assumption	Positivism	Interpretivism	Critical Social Science	The Current Study
<b>Epistemology</b> (Knowledge)	Only phenomena that can be observed can yield credible facts, data	Social phenomena and subjective meanings	Knowledge has a basis in historical practice, and no predefined measurements can conclusively prove or disprove a theory.	The current study will explain a phenomenon related to the use of social media for online shopping. It is a phenomenon that exists without the intervention of the researcher, and can provide credible data and objective facts that can be interpreted objectively.
<b>Ontology</b> (Nature of reality)	Objectivism, independent, external, objective and objective of social actors	Reality and meaning-making as socially constructed, subjective, changeable, multiple	Reality is produced and reproduced by human beings.	The current study approaches the phenomenon of social media use in online shopping objectively. That is, the views and beliefs of the researchers do not influence the development of the study or the phenomenon.
<b>Axiology</b> (Role of values)	Research is carried out in a manner that is value-free.	Researcher is biased through worldviews, cultural upbringing and experiences, which impacts the research.	Researcher considers the process of change to be a predominant factor in the lives of others.	There are no factors that influence the current study and its results except the phenomenon itself and the figures and statistics it yields.
<b>Methodological</b> (Research strategies)	Quantitative approach	Qualitative approach	Research practice may examine the manner in which others become educated.	The current study uses a quantitative method to collect data, then figures and statistical information are used to understand the phenomenon.

### **4.5 Purpose of the Current Research Study**

Evans et al. (2009) believed that a research initiative could be classified into three facets: explanatory, exploratory, or descriptive. Hence, the authors suggested that exploratory research is conducted when the topic under consideration has not been evaluated in previous studies. The primary objective of the exploratory process in the study is to gather as much basic information and data as possible to support subsequent studies. Saunders et al. (2009) claimed that exploratory research provides a platform to study and evaluate a new topic, especially if one is unaware of all the parameters involved regarding the subject. If this research is exploratory, multitudes of data would need to be processed to understand the topic. Normal buying patterns of Saudi online shoppers cannot be associated with the same patterns as walk-in clients in brick-and-mortar shops, so an entirely new approach is needed to discover how such online shoppers behave.

Gephart (2004) propounded the interpretive methodology as an efficient way to provide the necessary insights. This could be attributed to how such methodologies would further our understanding of human behaviour and the associated dynamics of that behaviour. Hence, such qualitative studies help create a clearer perspective, and provide a detailed explanation regarding aspects of behaviour in a social setting (Bryman & Bell, 2011). This also explains how undertaking an interpretive philosophy helps the researcher to conclude the factors related to online shopping behaviour.

An explanatory study focuses on the efficacy of the subject being considered. Correspondingly, this may be more related to the questions of 'how' and 'why', utilizing multiple tools like case studies and histories, or related experiments to explain the topic under consideration. These questions are associated with the ability to explain how certain phenomena occur over an extended period of time rather than specific instances in a particular time period. Yin (2003) found that individual case studies contribute to a clearer understanding of the entire process, rather than utilizing a corresponding exploratory or a descriptive process.

Nevertheless, the primary objective of this research is to comprehend the extent to which the current model enables researchers to understand the driving forces that determine the

## Chapter Four. Methodology and Research Plan

online behaviour of Saudi shoppers. The explanatory scope of this study depends on how well the study can be replicated with the available information and reproduced to achieve the study objectives. The model's predicative aspects are highlighted by the variance observed within it regarding the future behaviour of shoppers, which is beyond the scope of the current study.

According to Evans et al. (2009), a descriptive study provides a more realistic representation of the situation under consideration, since this is related to explaining and stating the observed situation and the behaviour concluded from the study. Alternately, a descriptive study lays the foundation on the basis of which exploratory research can be conducted. In this regard, it certainly helps to have an understanding of the issue under consideration, with the initiative undertaken to identify the specifics of the related variables in the study (Sekaran, 2000).

The design parameters are classified into either cross-sectional or longitudinal, with the former related to the collection of information and data from a specified population in a single initiative (Churchill & Iacobucci, 2002). Standard market research practices adopt this methodology, which can also be classified as single or multiple cross-sectional. The former entails collecting data and information from a single population, whereas the latter refers to at least two respondent pools (Saunders et al., 2012).

This study demonstrates how social media is influencing and affecting the trend of making online purchases within Saudi society. Correspondingly, this study can also be grouped with studies exploring the relationship between the listed aspects, for the purpose of which a descriptive methodology is adopted to provide the required input regarding the 'what is' paradigms (Gall et al., 1996).

A cross-sectional descriptive correlational design is utilised in this study by extending the OSAM to allow additional variables and align the results with the purpose of conceptualising the perception of online behavior, which requires greater details regarding the dimensions under consideration. Concerning the topic of online behaviour, previous studies probed a population of shoppers who have regularly shopped online (Jung & Loria,

2010). This initiative aims to gain insights into the phenomena by providing information on its physical and human aspects.

Such a process integrates the effects of social media on the topic under consideration, while it nevertheless excludes individuals and aspects that are secondary to the topic, or perhaps not directly related. Unfortunately, this introduces a bias to the sample, which can cause a major limitation. It makes sense to allow the incorporation of the descriptive research paradigms within the initial stages of the thesis since this provides input on aspects related to the questions of how, where, when, what and who. Descriptive research is also associated with statistical methodologies related to the explanation and documentation of information.

### **4.6 Research Approach**

An approach to research includes procedure and planning that is formulated for an investigation that span the steps from general assumptions to detailed methods of data collection, interpretation and analysis. However, there are two main investigative techniques – the quantitative and the qualitative approach (Rasooli, 2006).

#### **4.6.1 Qualitative Approach**

According to Rasooli (2006), the qualitative approach requires close proximity to the research object. It seeks to incorporate knowledge that will enable an interpretive understanding of the phenomena by offering an inside perspective (Yin, 2003). Qualitative data offers different implications through its non-standardized analysis process, and the complex nature of the data collected requires attentive sifting and coding (Phillips & Pugh, 2000; Collis & Hussey, 2009).

An advantage of the qualitative approach is that it facilitates direct contact between the researcher and participants. This method uses an approach that is adaptable in data collection and a process of inquiry that potentially provides greater insight into the issues affecting online shoppers. In accordance with Bryman (2012), qualitative research is more

adaptable than quantitative research because it allows more flexible insights and offers a summary of undesired results, which would lead to the need for further examination. Moreover, Creswell and Clark (2007) state that qualitative research asks participants to have a thought and identify the most possible responses. Nonetheless, Hromas et al. (1997) argued that the main disadvantage of this model is that its findings are not generalizable. Results vary depending on data interpretation and extraction (Malhotra & Birks, 2006).

### **4.6.2 Quantitative Approach**

According to Rasooli (2006), the quantitative approach involves distance and selectivity in relation to the object of research. This approach to data collection examines knowledge that is measurable and provides further explanations of real phenomena. Tull and Hawkins (1997) pointed out that its constructive purpose is to establish relationships among measurable variables.

Quantitative methods place more emphasis on numerical results as they look to minimize the influence of human factors. According to Hussey and Hussey (1997), the quantitative approach offers representative and objective results that are not influenced by the researcher. For instance, formal and large-scale questionnaires are distributed in an impersonal manner, and the responses are coded via statistical analysis (Malhotra, 2007; McDaniel & Gates, 2006). Manheim and Rich (1995) explain that quantitative research seeks to enhance direct retrieval of primary data from a given sample that supports the drawing of inferences about the larger population.

The data retrieved is utilized in validating or disproving the hypotheses set forth at the start (Malhotra & Birks, 2007). Quantitative research enables the researcher to test the validity and reliability of his hypothesis via statistical methods (Easterby-Smith et al., 2008). Thus, quantitative methods are capable of producing representative data.

The disadvantage of the quantitative approach is that when complex information is retrieved, it may contain rich details that are eliminated through the summative measures involved in the analysis process.

## Chapter Four. Methodology and Research Plan

Contrastingly, qualitative research shows particular levels of richness as it contributes detail to data. Moreover, quantitative research hides the contradictions and ambiguities that provide alternative explanations for the results (Denscombe, 2003).

This study incorporated quantitative research to ascertain results from a greater numerical foundation of knowledge that will justify the overall analysis of a variety of measurable variables. In fact, quantitative research will deliver a more objective macro-understanding of the influence of social media on the online shopping habits of the entire population in Saudi Arabia without being biased by the individual beliefs of the researcher.

Table 4.2 provides a detailed summary of qualitative and quantitative approaches, and compares them with that of the current study.

**Table 4-2.** Quantitative versus Qualitative

	Qualitative	Quantitative	Current Study: OSAM & Social Media
<b>Related to objective</b>	Identified by close proximity to the object	Selectivity and distance from object	The current study is quantitative in that the researcher aims to convert the findings into figures and statistics without any influence from the researcher’s beliefs or views. The phenomenon studied in the current research is not personal or subjective; it exists in the world regardless of the researcher.
<b>Sampling</b>	Small	Large	The sample used in the current study is a statistically significant, large sample.
<b>Research question</b>	How and why	What	The current study seeks to ask questions about the phenomenon, and what influences or causes it. The study seeks to define the phenomenon through figures and statistics.
<b>Aims</b>	Understanding through first-hand experience and quotations of actual conversation	Establishing relationships among measurable variables	The current study <b>explains</b> what the phenomenon is by converting facts into figures and statistics, which are used to understand the relationships between variables.
<b>Methods</b>	Predetermined	Hypotheses	The current study will collect quantitative data to test its hypotheses.
<b>Data</b>	Various implications	Statistical	The data gathered via questionnaire are converted into figures and statistics, which are then interpreted objectively.

### 4.7 Inductive and Deductive Approaches

A researcher may decide to follow either a deductive or inductive approach depending on several factors, such as the emphasis of the study or the nature of the research topic. These approaches dictate the direction of the research, that is, either beginning with the formulation of a hypothesis and moving towards data collection and analysis to test the



## Chapter Four. Methodology and Research Plan

hypothesis, or from collection and analysis of data to the formulation of hypotheses based on the data.

According to Wilson (2010), a deductive approach is one that is concerned with developing a hypothesis (or hypotheses) based on an existent theory. Here, the study is designed to examine hypotheses. This approach generally involves deducing conclusions from premises or propositions and, in most cases, begins with the expected pattern and is tested per the observations. In this approach, reasoning moves from more general to more particular observations and ultimately refutes or confirms the theory being tested. The opposite is true for the inductive approach.

An inductive approach requires competent knowledge and in-depth understanding of the research topic, which is instrumental in the formulation of alternative explanations of the problem. This approach involves reasoning, beginning with specific observations then moving towards broader generalisations and theories. Unlike in a deductive approach, where arguments are usually based on laws, rules, and accepted principles, arguments in the inductive approach are based on observations.

There are several criteria that can determine if a deductive or inductive approach will be most suitable for a project. The nature of the research topic is important in this regard. For instance, a topic on which there is a wealth of literature from which one can create a hypothesis and theoretical framework is better tackled by a deductive approach (Bryman & Bell, 2011). An inductive approach allows a researcher of a new topic that is still generating debate to generate and analyse data and then reflect upon whatever theories the data may suggest. Then the researcher can derive a hypothesis and theoretical framework.

Adopting a deductive quantitative approach, this study collects survey data to test a set of hypotheses as outlined in Chapter 3. It then presents a theory and examines theoretical postulates utilizing empirical data (Bryman, 2012). Furthermore, the time limitation factors into the rationale for applying a deductive approach, since an inductive study is more exploratory and requires a long process of analysing and collecting data for the purpose of developing a theory therefrom. However, the deductive approach is narrower in focus and examines a specific hypothesis or theory (Bryman & Bell, 2011).

### **4.8 The Questionnaire**

A questionnaire is a technique used to collect and record information on a certain issue of interest. It is mainly comprised of a list of questions, though it also contains instructions that are clearly stated and an empty space for administrative details or answers. A questionnaire can also be defined as any written instrument that offers a range of questions or statements to which participants respond by either drafting their own answers or choosing from the answers provided (Brown, 2008). Questionnaires have a definite purpose in relation to the research objectives. The purpose of the findings and how they will be used is clear from the outset. Respondents are informed about the purpose of the research wherever and whenever possible, and are alerted as about how to obtain feedback on the research findings.

#### **Questionnaire Administration**

The questionnaire was distributed to consumers who use social media for their purchasing activities. All respondents provided with a questionnaire were expected to complete it within the stipulated timeframe. The questionnaire was translated into Arabic to facilitate understanding among a larger population. Online surveys have more advantages in comparison to traditional mail surveys as they are both efficient due to reduced costs and effective in relation to the postage and printing processes (Andrews et al., 2003). For more on the advantages and disadvantages of online surveys, see Table 4.3. Theoretically, the Internet facilitates effective distribution of surveys to the online population. In addition, it allows online surveys to be conducted from any location.

This study utilized the online survey method as opposed to other methods, because the online method and the research share common ground in relation to Internet use. The online survey method more effectively reaches online shoppers and identifies the consumer population that uses online means for their shopping experiences. According to CustomerSat.com (1999), if respondents are familiar with the websites, the response and completion of online surveys is faster. Ranchhod and Zhou (2003) argue that people who take the option of answering online surveys are those with greater understanding of the

## Chapter Four. Methodology and Research Plan

technology and who usually use Internet extensively as a medium for communicating information. Although this raises a concern about the study's limitations, it can be overcome if the target population familiarizes itself with the Web and conducts their shopping online.

This study used online surveys that relay email links to respondents through their Facebook and Twitter accounts. This allowed more than 1,500 respondents to be recruited for this study. The questionnaire was active for approximately five months, from January to May 2015, and incorporated 53 questions divided into sections as discussed in Section 4.11.

The final version of the questionnaire was created via the online survey tool Survey Monkey. The completed Web-based questionnaire may be viewed through the Web link provided below. Furthermore, the questionnaire was generated in English and then refined through feedback obtained from various experts in the field of education, including the co-supervisor and supervisor of the researcher.

Moreover, a specialist in translation was given this questionnaire and asked to translate it into Arabic from English. Before commencing the fieldwork, the questionnaire was subjected to further refinement. It was translated into Arabic, and the accuracy of the translation was validated by the researcher's staff in Saudi Arabia, who recommended back-translation and a pilot test.

**Table 4-3.** Advantages and disadvantages of online surveys

Advantages	Disadvantages
Simple way to access a growing group of potential respondents (Bethlehem 2009; Chiu et al. 2014)	Online surveys are concise. Fram and Grady (1995) argue that consumers are more willing to respond to concise surveys. Therefore, online surveys should remain concise.
Can be accessed from any location at any time, thus offering ease of accessibility	Do not incorporate a representative sample of the entire population
It is convenient for online shoppers as it utilizes the population's online shoppers as the study's respondents. This eases accessibility and relevance of consumers to the setting (Szymanski & Hise, 2000).	Respondents may quit at any time, thus rendering it incomplete. Moreover, respondents may experience online technical problems, which may limit the entire process (Fricker & Schonlau, 2002; Heerwegh & Loosveldt, 2002).
The online approach is highly effective in identifying and communicating with online shoppers. Online shoppers are identified using a preliminary survey sent via e-mail.	Selection errors are rampant in online surveys when the sample is based on self-selection, because the researcher does not control the process. Also, the selection probabilities remain unknown, leading to biased estimations (Bethlehem 2009).
It enhances provision of more honest answers to questions pertaining to sensitive topics.	Online surveys are prone to random answers where respondents simply click any response to get the survey completed without understanding the process.

### 4.8.1 Questionnaire Design

A questionnaire was used to collect data in this particular study. Importantly, it was designed to ensure simplicity, concision and precision; however, the questionnaire was not short enough to maintain the interest of respondents. In fact, most participants gave up filling out the questionnaire immediately after realising how long it was. Research experts

## Chapter Four. Methodology and Research Plan

claim that questionnaires are not the most appropriate fit for participants because they take a large amount of their time and offer little or no emotional rewards (Nichols & Childs, 2009).

The researcher studied the fundamentals of questionnaire quality to ensure its successful development. For instance, the questionnaire was designed with an introduction section, which is essential in inviting participants to fill in the questionnaire. How captivating and convincing the introduction is determines the response rate. The introduction is supposed to be tailored to explain who the researcher is, why the researcher is undertaking the research, and how the respondents were chosen (Nichols & Childs, 2009).

In fact, a good methodology dictates that a questionnaire begin with the questions that are most important for the data collection, because some respondents may not fill out the entire survey. This way, if they complete only half, it can still be used in the analysis. Moreover, the reason for putting personal information at the end of the questionnaire is to ensure that respondents consider such questions after a rapport has been created (Brown, 2008).

Questionnaires can contain a mixture of closed, open and multiple-choice questions. The questionnaire developed for this study is a combination of the three. In the case of closed questions, the respondents are somewhat restricted to choose among certain answers. By contrast, open questions give participants the freedom to write whatever answers they think most suitable. Multiple-choice questions give respondents a choice of options from which they are supposed to identify the most appropriate choice (Potter, 2003).

Further, the questionnaire should be designed in a way that is attractive and makes data entry easy. This implies that the questions and layout should be simple in order to facilitate the entering and decoding of data in spreadsheets. Therefore, the answers should all be lined up on the right side of the questionnaires (Smith, 2008).

The different measurements that can be used in a questionnaire include nominal, ordinal, interval and ratio. Nominal is the major focus of this particular study, as nominal variables enumerate different categories of participants. Therefore, a question is determined to be nominal if the answers require a participant to fit into one category among several available (Nichols & Childs, 2009). An ordinal variable can be identified through identity and

## Chapter Four. Methodology and Research Plan

magnitude. Ordinal variables place hierarchical value (Constantinos et al., 2003). Interval variables have the properties of identity, magnitude, and equal intervals between points; however, since interval scales do not have an absolute zero point, the ratio of two scores cannot be meaningful. Such scales are normally constructed by adding together several separate questionnaire items that indicate a concept. Ratio scales have all the properties of interval scales as well as a true zero point. Therefore, all mathematical operations are appropriate, including taking the ratio of two numbers. Moreover, data from ratio scales are also sometimes called 'score data'. Examples include height, weight and age (Constantinos et al., 2003).

The last step in designing a questionnaire—pilot testing—is a critical part of an online survey process as it provides the opportunity to test all aspects of the survey in advance, thus ensuring the smooth operation and success of the actual online survey. Further, it aims not only to make sure that the target audience understands and responds to the questions in the expected way, but also to test the technical functionality of the online survey (Nichols & Childs, 2009). The effort put into conducting an online survey is wasted, however, if the online survey networking set-up does not work correctly and efficiently. Thus, this pilot test also aims to establish initial reliability. The critical issues and problems encountered in both the questionnaire and the technical aspects at this stage should be corrected well before the launching of the main survey (Constantinos et al., 2003).

If we test the questionnaire with only a few respondents to discover and eliminate any possible difficulties, this is pilot testing (Hunt et al., 1982). All aspects of the questionnaire, such as wording, question content, form and layout, sequence, question difficulty and the clarity of instructions are tested by conducting pilot surveys. Moreover, researchers test computer programming language, coding and data editing, data tabulation and processing in this way.

The initial questionnaire, including the OSAM, was drawn up by Zhou et al. (2007). However, to test the social media construct in the current study, questions about social media were added and several questions from the original questionnaire were removed since they were irrelevant. It is important to clarify that the OSAM is a summation of up

## Chapter Four. Methodology and Research Plan

to 40 positive and negative technological belief statements, each associated with one of the six factors comprising the OSAM dimension. Additionally, each of the items was graded on a scale of 1 to 7 on a Likert scale, where 7 indicates strong agreement and 1 indicates the opposite. Appendices 3 and 4 provide the survey in English and Arabic, respectively. Ratio scales have all the properties of interval scales as well as a true zero point. Therefore, all mathematical operations are appropriate, including taking the ratio of two numbers. Moreover, data from ratio scales are also sometimes called ‘scores’.

The first page of the questionnaire provides an introduction and a welcome, offering gratitude to participants for their involvement. Then, as illustrated in Appendix 3 or visit the [link of survey at https://www.surveymonkey.com/r/?sm=138C%2fsKXuiUINbND6GTlpw%3d%3d](https://www.surveymonkey.com/r/?sm=138C%2fsKXuiUINbND6GTlpw%3d%3d), the questionnaire is divided into seven sections. The first section introduces the survey. The second seeks to measure Internet experience. The third provides a deeper understanding of social media use, e.g., frequency of social media usage, by analysing a list of social media websites stipulated by Mikalefet et al. (2012). This study identified a list of social media websites from which users can select multiple items in accordance with the sites where they have created accounts. Options are also provided that facilitate the integration of additional social media websites not initially included. The fourth section focuses on online shopping. The fifth analyses online and social media users’ intention to purchase goods online, and defines the respondent’s intention to share information. The sixth section analyses the impact of social media in surveying shopping motivation together with the online experience. The final section inquires into the socio-demographic characteristics of respondents that are investigated the most – namely, the **acceptance** of online shopping (Grunert & Ramus, 2005). Studies that utilize demographic information in the identification of various consumer groups associated with online shopping show that gender, age, education, income, and social status influence one’s tendency to utilize online shopping (Verhoef & Langerak, 2001). Thus, they are key to this study’s inquiry.

### **4.8.2 Likert Scale**

A Likert scale is a standard of measurement frequently used in survey questionnaires, which has been developed to assess a person's attitudes (Likert 1932). As discussed above, four primary scales are used in questionnaires – nominal, ordinal, interval and ratio.

The nominal scale is a procedure for assigning a number to an object, property or concept in order to identify the thing to be measured (Burns & Bush, 2006). This scale can be based on natural categories like gender (male or female) or artificial categories like education. Examples include: did not attend school, primary school, elementary school, secondary school, BA degree, MA degree, PhD degree.

The ordinal scale involves the ranking of individuals, attitudes or items along a continuum of the characteristic being scaled (Argyrous, 2011; Antonius, 2013). For instance, an item may ask students to rank ten types of classroom activities from most to least interesting (Burns & Bush, 2006).

In statistics, the use of an arithmetic mean can only be justified through the adoption of interval scale-related data. Thus, interval scale data is particularly useful in this study. The rationale is that the interval scale embraces equal units of measurements, which makes it possible to interpret the scale score order (Burns & Bush, 2006).

It is important to determine if the wording of a scale is positive or negative. The scale can contain a variety of statements, such as dichotomous ratings and bivalent labels. An example of dichotomous rating is “agree” or “disagree”. In the case of bivalent labels, the example becomes “strongly agree” or “strongly disagree” (Dillon et al., 1994). These statements are often numbered from 1 to 9; however, some studies extend the scale to 11 (Russell & Bobko, 1992). The most common are scales ranging from 1 to 5 or 1 to 7 (Burns & Bush, 2006).



**Table 4-4.** Interval scale

	Strongly disagree	Disagree	Sometime disagree	Nature	Sometime agree	Agree	Strongly agree
<b>Score</b>	1	2	3	4	5	6	7

Among all the levels of measurement, the ratio scale is most common. A ratio scale measures variables such as weight, time and length. A ratio scales offers benefit in that it provides a comparison between scores and their relative magnitude (Burns & Bush, 2006).

Differences in the scales of measurement are vital to the researcher since they aid them in determining the best statistical analysis in each specific case.

This research study uses a measurement instrument containing 24 statements developed from 6 major dimensions of the OSAM – online shopping, online shopping experience, social media, online shopping intention, shopping motivation and shopping orientation. This approach accurately assesses the new model (interval scale).

As elucidated by the study, the six dimensions used are divided into two sets of statements; the initial set of statements is worded positively, and the second set is worded negatively. While observing the essentials of scale development, the scale here is designed based on a 7-point scale ranging from "strongly agree" (1) to "strongly disagree" (7). Points 2 through 6 feature no verbal statements. Below is an illustration:

IA1: Social media provides me with quick access to large volumes of information about products or services.

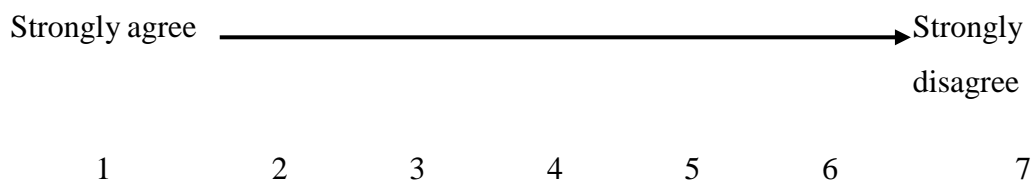

OE1: I am experienced at online shopping with the use of the social media sites.



First, some measurement items utilize 7-point interval scales as identified in previous studies (Al-Maghrabi et al., 2009; Mikalef et al., 2012; To et al., 2007). Secondly, the 7-point range provides the possibility of a wider spread, which enhances effective evaluation of the respondents' level of perception, as compared to the 5-point scale (Tharenou et al., 2007). This study gives respondents the opportunity to have a preference over each response category within a larger number of scale points. Moreover, an increase in the number of intervals makes larger variance possible, which leads to increased reliability (DeVellis, 1991). Thirdly, Malhotra (1996) states that more categories such as 7 or more are needed within the data analysis process, for utilizing sophisticated statistical techniques.

### **4.9 The Research Model**

As mentioned in Chapter 3, the OSAM framework contains the main determinants of online shopping intention. It was clear that various researches have used the TAM, and these researches have added the social media factor for the initial theory depending on the nature of the research. In addition, the TAM theory underwent modifications to adapt to the particular environment and content of these studies.

### **4.10 Reliability and Validity**

How can researchers ensure that the instrument used for data gathering measures the required variable in a consistent manner? Some questions can only obtain valid answers by establishing reliability and validity. These two aspects of research design are discussed in the following section.

#### **4.10.1 Reliability**

Reliability can be broadly described as the degree to which measurements are repeatable when taken by different people in dissimilar occasions under different settings and with different instruments. It generally refers to the uniformity or stability of measurements over different conditions where similar results are expected; however, even though reliability is a requirement for quality research, the data obtained is never 100% accurate, and this may occur either as random or systematic error.

Random error is easily cancelled out by taking the average of the measurements; however, systematic error cannot be cancelled out by taking the average, and it usually exacerbates the inaccuracy of the results (Saunders et al., 2012; Cooper & Schindler, 2008). Systematic errors are the main concern for validity. Although reliability is a necessary condition for validity, it is not enough to ensure validity on its own. A reliable measure is one that is entirely devoid of random error, and nothing else in the definition of reliability requires that the measure is valid. A measure can, therefore, be very reliable but still fail to be valid (Bollen, 1989).

## Chapter Four. Methodology and Research Plan

Typical methods utilized for test reliability estimation include split-halves, internal consistency, test-retest reliability, alternative forms, and inter-rater (Corbin, 2008). Reliability testing deals with three main areas – internal consistency, overtime consistency and equivalence consistency (Bryman & Bell, 2011). Test-retest reliability refers to the sequential measurement stability from one particular session to another. Moreover, the recommended procedure involves administering a test to a group of respondents and then administering a similar test to the same group of individuals on a later date.

The correlation between the same test given on various occasions was defined as test-retest reliability (Saunders et al., 2012). However, this technique has its limitations (Rosenthal & Rosnow, 1991). For instance, if the period between the two tests is too short, the respondents may know from the first test how to answer questions the next time the same test is administered, and thus may provide biased information. Additionally, if the duration is too long, respondents may have experiences that change their opinions, feelings and attitudes about the behaviour being studied. This effect is referred to as ‘maturation’.

The alternative forms technique is used in estimating reliability, similar to the test-retest technique except that various measures of a variable are gathered at different times (Saunders et al., 2012). If the correlation between the two results is low, then there is a considerable error in measurement. Several limits to the test-retest method also apply to the alternative forms technique (Saunders et al., 2012).

The split-half approach is the other method used to assess the reliability of a measurement whereby it is assumed that several items are available to measure a behaviour. Half of these items are joined to form a single new measure, and the other half are combined to make another. This results in two new tests for two new measures, both of which examine the same behaviour. Unlike the previous two techniques, the split-half approach is carried out simultaneously. The correlation between the two halves is then corrected to get the coefficient of reliability for the entire test.

The split-half method has an advantage over the test-retest and alternative form techniques since the effects of memory do not impact this approach and the split-halves are cheaper and easier to obtain as compared to data collected over time. The disadvantage of the split-

half method is that the examined tests have to be parallel measures, which means the correlation differs slightly depending on how the items are divided.

Inter-rater reliability assesses the reliability of judgments or the combined internal consistency of raters or judges used to measure behaviour. For instance, when two judges assess ten subjects, the correspondence of ratings obtained from these two judges will help in determining how reliable the two judges are in a particular situation. The compound reliability of the two raters or judges, also known as 'effective-reliability', is obtained by use of the Spearman-Brown calculation formula (Rosenthal & Rosnow, 1991).

Internal consistency is concerned with the reliability of test components (Schwab,1980). It measures the consistency of the instrument and tries to answer the question of how well the chosen items can measure a certain behaviour (Hair et al., 2010). For a test to be termed internally consistent, approximates of reliability are found to be on the average of inter-correlations among each individual item within a test. The most commonly used technique for testing internal consistency is the alpha coefficient, popularized by Cronbach, who recognized its usefulness, hence the adoption of the name 'Cronbach's alpha' (Hair et al., 2010).

The reliability of a test is affected by several factors, thus preventing measurements from being exactly replicable. Distinguishing between errors of measurement and errors of instrumentation is important since they affect the reliability differently and are corrected differently. Sampling is a major source of error within a test. It is mostly corrected by increasing the sample size, as the higher the number of respondents, the lower the chances of getting inaccurate results. This is because each respondent has the same probability of answering correctly. Cronbach's alpha is the correct measure of reliability in such cases where errors occur due to item sampling.

### **4.10.2 Validity**

The exact nature of validity as used in social and educational studies is widely debated, and there is no single definition that is universally accepted (Pedhazur & Schmelkin, 1991).

## Chapter Four. Methodology and Research Plan

Different scholars define validity differently, but the common concept on which all agree is that there is a level of accuracy in measuring a variable. They aim to answer whether a certain indicator actually measures what is meant to be measured and also if it is the best choice of indicator for the said variable. One of the most cited definitions of validity is that of Winter (2000), who wrote, “An account is considered true or valid if it accurately stands for those phenomena features that it planned to explain, describe or theorise.” Many authors have developed other terms and definitions, but all revolve around the same concept (Cooper & Schindler, 2008).

Validity is not to be confused, however, with precision. The more precise a measure, the more difficult it becomes to attain high levels of validity. For instance, time may be measured in how many milliseconds it took a child to complete a test that lasted for approximately one hour. The extra degree of precision in this case is highly unlikely to produce a greater degree of validity. Similarly, in most qualitative research where a high degree of accuracy is desired, over-precision is avoided since such results can confound or obscure the general purposes of the study. Nevertheless, validity is not a unitary concept as Hitchcock (2012) suggests.

Perceptions of validity vary depending on the research topic (Cooper & Schindler, 2008). This depends on the researchers and their beliefs regarding what stage of the research process requires validation – e.g., the measurement, scores, instruments, or observers – as opposed to the research process as a whole. According to Cooper and Schindler (2008), there are five types of validity related to different stages in the study process: theoretical, generalizability, interpretive, evaluative and validity.

Descriptive validity measures how the facts appear to be accurate from the researcher’s perspective, and thus acknowledge the vital role played by the one conducting research in the process of research (Waltz et al., 2005). It is concerned with data collection in the early stages of research. If various observers or methods of data collection generate different accounts of similar events or situations, then there is a question of descriptive validity (and consequently other kinds of validity as well) of the methods and accounts. Researchers consider doing a pilot study to ensure that validity is not compromised in these initial

## Chapter Four. Methodology and Research Plan

stages. Qualitative research, however, acknowledges that in studying human systems, contradiction is inevitable and should thus be investigated further; however, this is unacceptable in quantitative research.

Regarding interpretive validity, a measure is only valid or true if the actors or participants can confirm and recognize the findings. It measures the extent to which an interpretation is representative of the understanding of the underlying group (Hitchcock, 2012). A valid measure should respect the perspectives of the participants from which data are being collected. This applies mostly to qualitative research, since quantitative research is more objective; that is, it would be impossible for a reasonably constructed interpretation in a quantitative study to be rendered invalid based on the failure to be confirmed by the factor.

Valid theory is used to measure the extent to which an explanation of theory is obtained from the study results (Saunders et al., 2012). This type of validity is very specific to the research itself and to the emotional and mental constructs of the researcher. It is most commonly used for qualitative research (Waltz et al., 2005).

Evaluative validity measures the extent to which an evaluating framework can be applied to the study objects. Evaluation in research is inevitable; therefore, both the qualitative and quantitative approaches need to consider this form of validity seriously as it contributes to the overall validity of the study (Waltz et al., 2005).

Generalizability refers to the study's degree of reproducibility where the researcher can deduce from a specific event general truths that apply to another time, setting or context. Maxwell (1992) further classifies it into internal and external generalizability. Internal generalizability is the application of the same results within the underlying setting or group, and external generalizability refers to generalizability outside the confines of the study's population, time, setting, or context. Maxwell also explains that internal generalizability is more important than external in qualitative research.

A central part of developing any scale is establishing its content validity, construct validity, uni-dimensionality, and reliability. Content validity has been defined differently by various authors (Wynd et al., 2003; Waltz et al., 2005), but the general consensus is that content validity measures the degree to which a selected sample represents every single element in

a sample. It is important to consider in both qualitative and quantitative approaches since it determines the accuracy of the research in general. Sample representation is of particular concern in quantitative research.

Construct validity refers to the degree to which a test measure adequately measures what it claims to. Researchers must be careful in selecting their indicators since these are what are used to test the hypotheses and ultimately determine the validity of the research along with other measures of validity. Furthermore, other measures of validity, such as face validity, content validity and criterion-related validity, all contribute to the overall construct validity of a study.

### **4.10.3 Model Validity and Reliability**

To ensure the validity and reliability of the questionnaire, the questions were asked in a straightforward manner that prevented unwanted interpretations. Additionally, pilot tests were conducted with five Saudi researchers in two phases. This process helped identify the amount of time required to complete each phase of the questionnaire. This limits the occurrence of problems during the administration of the questionnaire (Zhou et al., 2007). Also, questionnaires were developed in English and translated into Arabic. This incorporated the method of back-translation to limit any form of bias (Brislins, 1986).

#### **4.10.3.1 Pre-testing**

According to McDaniel and Gates (2006), all the editing and writing did not ensure success. Pre-testing is the cheapest way of ensuring the success of a research questionnaire. Ensuring that the questionnaire offers respondents questions that are understandable and clear that will generate answers which are understandable is the key purpose of a pre-test. The research questionnaire was first pre-tested among a convenience sampling of five researchers who had worked with questionnaire design and had relevant experience.



## Chapter Four. Methodology and Research Plan

The five respondents were requested to give comments in regards to the wording and relevancy of the survey, its length and the time required for completion of the important questions to obtain feedback from individuals with diverse expertise, since their suggestions can be helpful regarding item additions and deletions as well as ways to improve the wording of the items. This limited the occurrence of problems during administration of the questionnaire (Zhou et al., 2007).

However, the researcher was advised that few respondents who started the questionnaire would complete it fully because it included 53 questions and took more than 10 minutes to complete. Thus, the research was revised to focus on one main factor, so shopping orientation was measured by different types of shopping, such as shopping at home, economic, recreational, mall and local. Therefore, 6 questions were deleted (see Table 4.5). Furthermore, it was suggested that the questionnaire be divided into seven sections as opposed to five: an introduction, Internet experience, and social media, online shopping, online shopping intention, and shopping motivation.

**Table 4-5.** Editing survey

Before editing	After editing	Reference
<b>Shopping Orientation (SO)</b>		
<p>SO 1: I like to shop from home (e.g., using mail order catalogues, TV or Internet).</p> <p>SO 2: I shop from home because I cannot find what I want in local stores.</p> <p>SO 3: Shopping from home is more convenient than going to the store.</p> <p>SO 4: I make it a rule to shop at a number of stores before I buy.</p> <p>SO 5: I can save a lot of money by shopping online.</p> <p>SO 6: I like to have a lot of information before I buy products or services online.</p> <p>SO 7: I enjoy going to big shopping malls.</p> <p>SO 8: Shopping malls are the best places to shop.</p> <p>SO 9: I like to go to shopping malls with a friend.</p> <p>SO10: I often combine going to shopping malls with lunch or dinner at a restaurant.</p> <p>SO 11: Shopping malls give me a chance to get out and do something.</p> <p>SO 12: I like to shop in shopping malls where people know me.</p> <p>SO 13: I owe it to my community to shop at mall.</p>	<p>SO 1: I like to shop from home (e.g., using mail order catalogues, TV or Internet).</p> <p>SO 2: I shop online because I cannot find what I want in local stores.</p> <p>SO 3: Shopping online is more convenient than going to the store.</p> <p>SO 4: I can save a lot of money by shopping online.</p> <p>SO 5: I like to browse a lot of information on social media sites before I buy products or services online.</p>	<p>Vijayasathy, 2002</p>
<b>Online Shopping Intention (OSI)</b>		

## Chapter Four. Methodology and Research Plan

<p>OSI1: When I need to buy a particular product or service, I search for a social media website that has the product or service.</p> <p>OSI2: I would likely visit a social media site to shop for my needs.</p> <p>OSI3: I plan to do more of my shopping via social media sites.</p> <p>OSI4: I buy products I see advertised on social media.</p> <p>OSI5: I intend to buy the products offered on social media sites in the near future.</p> <p>OSI6: I would consider buying from social media sites in the near future.</p> <p>OSI7: It is likely that I will buy a product from social media sites in the near future.</p>	<p>OSI1: When I need to buy a particular product or service, I search for a social media website that has the product or service.</p> <p>OSI2: I intend to buy products or services I see advertised on social media.</p> <p>OSI3: I intend to purchase online through social media sites in the near future.</p>	<p>Mikalf et al., (2012)</p>
<p><b>Trend Discovery (TD)</b></p>		
<p>TD1: Social media provides a great platform to exchange information about products with my friends.</p> <p>TD2: Through social media, I can be informed and effectively share my experience of a newly purchased product or service with others.</p>	<p>TD1: Social media provides a great platform to exchange information with my friends regarding products or services.</p> <p>TD2: Through social media, I can be informed and effectively share my experience of newly purchased products or services with others.</p>	<p>Mikalf et al., (2012)</p>
<p><b>Socializing (SO)</b></p>		
<p>SO1: Social media provides a great platform to exchange information with my friends regarding products.</p> <p>SO 2: Through social media, I can effectively share my experience of a newly purchased product or service with others.</p>	<p>SO1: Social media provides a great platform to exchange information with my friends regarding products or services.</p>	<p>Mikalf et al., (2012)</p>

SO3: I can make new friends with other shoppers through social media websites.	SO1: I can make new friends with other shoppers through social media websites.	
--	--	--

**4.10.3.2 Pilot Study**

Hand in hand with the pre-test, a pilot study was initiated with the aim of attaining 100 responses. A small-scale pilot survey enables researchers to observe patterns in respondents’ answers and any issues with the questionnaire, reliability and viability testing and also all questionnaire work-parts identification. In addition, some adjustments can be made to improve the clarity. The final questionnaire is shown in Appendix 3.

**4.10.3.3 Measures**

To enhance the validity of measurements while operating the research constructs, it is pertinent to identify which items have been validated in previous research. As seen in Table 4.6, all reflective items, especially those pertaining to shopping motivation and social media use, were developed and validated by Mikalef et al. (2012). These were utilized in to measure shopping intentions on social media. Online shopping and online intentions were assessed by incorporating measures from previous studies such as Zhou et al. (2007). Social media usage in online shopping intention is measured from the resulting consumer demographic, through a review of the relevant literature (Zhou et al., 2007; To et al., 2007). Likewise, social media usage in online shopping intention is measured from the resulting consumer demographic, through a review of the relevant literature (Zhou et al., 2007; To et al., 2007).

**Online Shopping** was measured with two items from Zhou et al. (2007) and Dai et al. (2014), respectively. The items were used to assess pediatricians’ subjective views of

purchasing online. In fact, previous research has found that the two-item measure has good reliability (Cronbach's alpha = 0.80-0.86).

**Online Shopping Experience** was measured with two items from Zhou et al. (2007) and Dai et al. (2014), respectively. The items were used to assess paediatricians' subjective view of past purchasing online. Previous research has found that the two-item measure has good reliability (Cronbach's alpha = 0.90-0.92).

**Social Media** was measured with six items from Mikalf et al. (2012). **The items assessed social media use in online shopping. Previous research has found that the two-item measure has good reliability (Cronbach's alpha  $\geq$  0.6).**

**Shopping Motivation** was measured based on Mikalf et al. (2012)'s concepts of utilitarian motivation and hedonic motivation. These particular items were used in this research to determine factors such as product selection, convenience and authority. Previous research has pointed out that Cronbach's alpha gave the measure of reliability when the values ranged between 0.490 and 0.889.

**Online Shopping Intention** was measured with three items from Zhou et al. (2007) and Mikalf et al. (2012). The items were used to assess paediatricians' subjective probability of purchasing online. Previous research has found that the two-item measure has good reliability (Cronbach's alpha = 0.474-0.722).

**Shopping Orientations** used three of the total five items of measurement that were determined to be reliable. The reliability of the five items was determined using Cronbach's alpha values ranging from 0.774 to 0.839. The items were meant to assess the relationship between shopping orientation and online shopping orientation (Vijayasathy, 2002). The table below illustrates the validity of the variables used in the study.

**Table 4-6. Variables used in the study**

	Zhou et al. 2007	Mikalef et. al (2012)	Xiang & Gretzel, 2010	López et al., (2011)	Pöyry et al., (2012)	To et al., (2007)
Online Shopping intention and Demographic	☐					☐
Online Shopping intention and social media		☐	☐	☐	☐	
Online Shopping intention and Online shopping Experience	☐					☐
Online Shopping intention and Online Motivation	☐				☐	
Online Shopping intention and online shopping	☐					
Online Motivation and Online Intention	☐					
Online Motivation and social media use		☐				
Online Motivation and online experience	☐					☐
Online shopping experience and social media use		☐				

### 4.11 The Research Model Constructs

This section brings to light all the constructs of the extended OSAM, which includes constructs motivated by the initial theory as well as constructs proposed by the research at hand (see Fig. 4.1 and Table 4.7). **However, it may well be time to challenge conventional measurement wisdom in management research concerning the use of two-item measures. While the latter do not in any way present a sound measurement option under all circumstances, there are conditions under which they do; therefore, the use of two-item measures should not be considered a flaw in the review process (Fuchs & Diamantopoulos, 2009).**

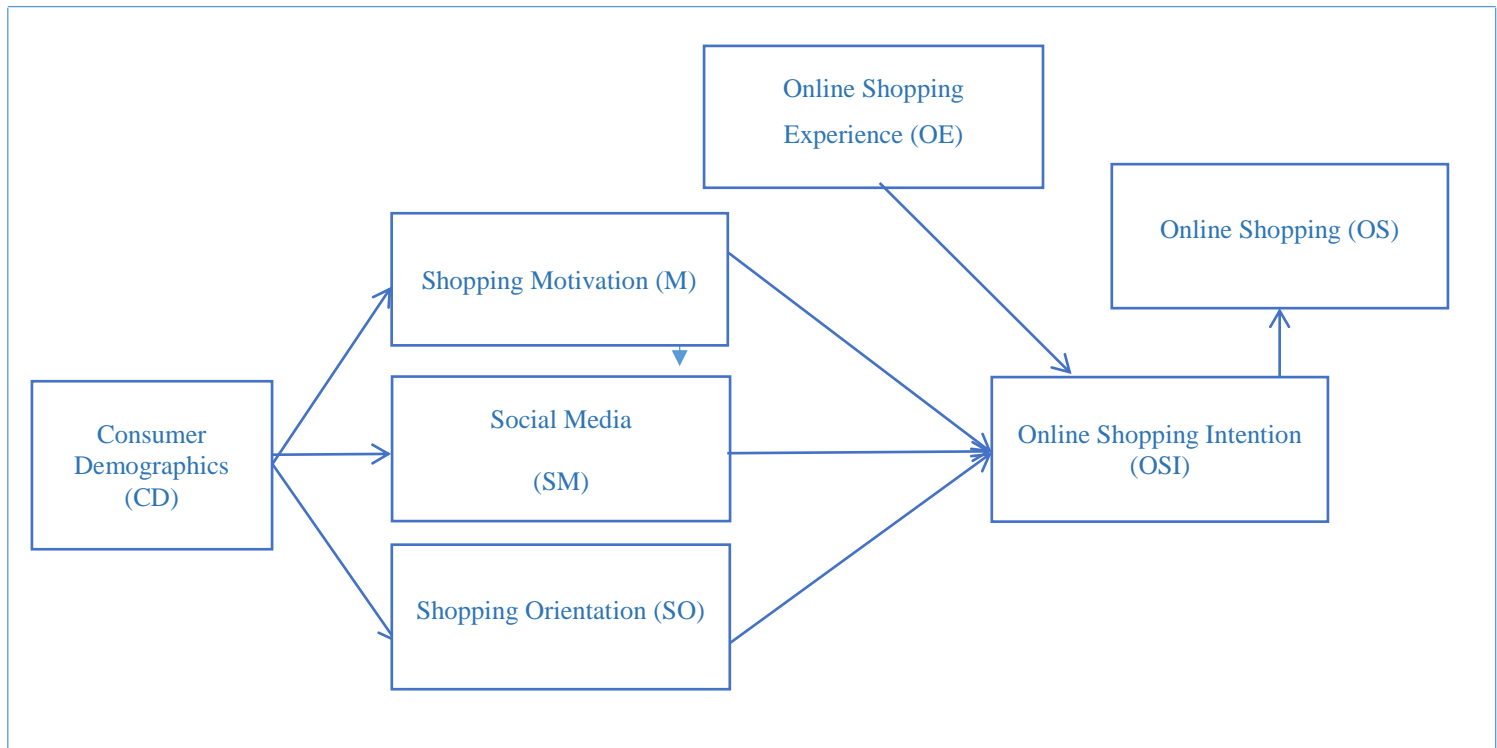

**Figure 4-1.** The Research Model

#### 4.11.1 Online Shopping (OS)

Online experience has been proven by several authors to affect online shopping intentions (Zhou et al., 2007; Dai et al., 2014). Online shopping is a very broad concept consisting of several facets, including how long the respondents have been using the Internet, how often they have shopped for goods and services online, which websites have they been shopping from, if they use social media websites to shop or make decisions about online shopping, and how much money they have spent on online shopping. However, for the goal of this research, only three of these aspects were considered (Fig. 4.1)—how long participants have been using the Internet, how often they shop online, and how much they have spent on online shopping (Dai et al., 2014).

Respondents were asked to rate the following:

1. I feel comfortable using social media sites to purchase online.

2. I feel that social media sites are easy to use when I purchase online.

#### **4.11.2 Online Shopping Experience (OE)**

Previous online experience was measured first by asking participants how long they have been using the Internet, and the responses categorized on an interval scale where 1 = less than 1 year, 2 = 1-2 years, 3 = 2-3 years, 4 = 3-4 years, 5 = 4-5 years and 6 = more than 5 years.

Online experience was measured by asking participants how often they have shopped online on average of one month. The results were categorized as follows: 1 = Never, 2 = 1-2 times, 3 = 3-4 times, 4 = 5-6 times, 5 = 7-8 times and 6 = more than 8 times. Also, respondents were asked about the total amount of money they spent on online shopping in the past year, and responses were classified in intervals as follows: 1 = SR 0-250, 2 = SR 251-500, 3 = SR 501-1,000 4 = SR 1,001-5,000, 5 = SR 5,001-7,500 and 6 = SR 7,501-10,000 and 7 = more than SR 10,000. Online experience was also measured by asking participants direct questions that required Yes/No responses (1 = yes, 2 = no).

Finally, respondents were asked to rate the following:

1. I am experienced in purchasing online through a social media site.
2. I feel competent using a social media site when I purchase online.

#### **4.11.3 Consumer Demographic (CD)**

As discussed in Chapter 2, various types of demographic variables impact purchase intentions of consumers online. Demographic factors such as age, gender, level of income and education have been examined in several studies. This study measured several consumer demographics that influence online shopping intentions—1) gender, 2) age, 3) income level and 4) education (Zhou et al., 2007).

##### **Gender**



## **C**hapter Four. Methodology and Research Plan

As discussed in Chapter 2, all of the studies in the literature review except for one show that gender has an influence on intention to shop online, and many studies bring to light that males are more likely to shop online than females (El-Ansary & Roushdy, 2013; Doolin et al., 2005; Fan & Miao, 2012; Thamizhvanan & Xavier, 2013; Zhou et al., 2007).

### **Age**

In most studies, age is found to have a negative or positive effect (El-Ansary & Roushdy, 2013; Doolin et al., 2005; Fan & Miao, 2012; Zhou et al., 2007). Three of the studies show that there is no significant relationship between consumers' intention to shop online and age (Doolin et al., 2005; Thamizhvanan & Xavier, 2013; Van Slyke et al., 2002).

Age was also measured by asking respondents about their age and then transforming that number into an interval scale for data analysis (Kent, 2007) i.e., 1 = 19-24 years, 2 = 25-29 years, 3 = 30-35 years and 4 = 36 years and above.

### **Education**

Among the demographic variables, education is considered as one of the key factors. It has been shown that educated people are more likely to shop online than less educated people (Thamizhvanan & Xavier, 2013; Punj, 2011; Zhou et al., 2007). Thus, education level was measured by the highest level of education achieved by the respondent, ranging from primary level to postgraduate degree.

### **Income**

Income has been analysed in most of the studies reviewed, and it has been shown that consumers who have high levels of income are more likely to practice online shopping than consumers with lower levels of income (Zhou et al., 2007). There is a statement that indicates purchases done online have a relationship to shopping online (Zhou et al., 2007; Wang et al., 2012). Thus, the income was measured by the highest level of monthly income achieved by the respondent, i.e., 1 = less than SR 2,000, 2 = SR 2,001-5,000, 3 = SR 5,001-8,000, 4 = SR 8,001-12,000, 5 = above SR 12,000.

### **Product Characteristics**

Product characteristics were measured by asking respondents which of several listed products or services were necessary and which were important (Zhou et al., 2007). However, shopping online experienced measurement as consumers' responses towards buying various types of products on Internet in the previous ages. Four product categories were identified by The Nielsen Corporation (a global marketing firm), which has reported that, across the globe, the most popular items purchased on the Internet are as follows (Nielsen Global Consumer Report, 2010):

1. Books;
2. Clothing, accessories, shoes;
3. Airline tickets;
4. Electronic equipment; and
5. Videos, DVD, games.

### **4.11.4 Social Media (SM)**

Utilization of social media is common today, and this impacts intention of online shopping both directly and indirectly. Through social media, most people interact and share opinions and views about products that are advertised online, and this directly influences consumers' intention to shop for items and services online (Chen, 2014). When shopping online, some people first check the comments of their friends about a certain product on social media before making a decision to purchase (Grunert & Ramus, 2005). However, it is less likely that people will buy a product after a friend recommends it on social media sites than when they see the product on a regular website, especially when it is receiving positive feedback from the majority of users (Chen, 2014).

Frequent use of social media also increases a person's level of online experience. This is because a person who visits social media websites more frequently will have a higher chance of purchasing items or services online as compared to one who rarely uses social media. Furthermore, social media provides a good platform for advertising products and services (Kuhlmeier & Knight, 2005), and manufacturers are increasingly utilizing this

## Chapter Four. Methodology and Research Plan

opportunity by providing links for consumers to purchase or provide feedback. This increases the chances of someone purchasing the products online as compared to when they see the same ads on other websites.

The questions examined information on the frequency of social media use by participants and also whether they purchased items they saw on social media websites (Crano et al., 2005). The questions are arranged as follows:

1. Have you joined any social media site?
2. Which social media website do you use most often?
3. How much time do you spend on social media networking websites in a day?

Mikalf et al. (2012) illuminates the criteria for selecting social media websites. In observance of these particular criteria, the researcher developed a list of the websites used for social media purposes. The researchers considered whether the users had accounts with these particular websites and if they did multiple item selection. There is a window for respondents to add more social media platforms not initially identified by the users. However, this is subject to determination if they really belong within the category of social media. Therefore, names that were found to be irrelevant were struck from the list.

Frequency of social media use for online shopping will also be measured to test the hypotheses (Mikalf et al., 2012). Respondents were asked about their frequency of online transactions through social media within the past month, and responses were classified according to the following interval scale: 1 = Never, 2 = 1-2 times, 3 = 3-4 times, 4 = 5-6 times, 5 = 7-8 times and 6 = more than 8 times.

In addition, to assess the degree to which users of social media engage in the process of using such sites to browse for products, respondents were asked to rate the following:

1. Social media provides a wonderful means to find products or services online.
2. I use social media to browse products or services on company-hosted pages when I am online.
3. I will continue to browse products and services online via social media websites in the future.

#### **4.11.5 Shopping Motivation (M)**

##### **Convenience (CO)**

To examine the degree of convenience that social media sites offer for product browsing (To et al., 2007), respondents were asked to rate the following:

1. Social media websites are a convenient medium since they enable me to find products or services whenever I want.
2. It is convenient to find products or services through social media since I can do so from the comfort of my own home.
3. Through social media, I can find products or services in accordance with my schedule.

##### **Information Availability (IA)**

Information availability can be defined as the accessibility of the information that is needed for a particular product or service by a shopper on a social platform (To et al., 2007). To assess information availability, respondents were asked to rate the following:

1. Social media provides me with quick access to large volumes of information about products or services.
2. I can collect useful information about a products or services I want through social media websites.
3. Comments by other users of social media websites help by giving feedback about the products or services being advertised.

##### **Product Selection (PS)**

A selection of products is found on company-hosted social media sites (To et al., 2007). To obtain information on product selection, respondents were asked to rate the following:

1. Social media helps me find products or services that I was unfamiliar with.
2. I can find a wide selection of products or services on one website through social media.

3. With social media, I can browse a large array of products or services.

**Customized Advertisements (CA)**

The compatibility of customized advertisements is presented to users of social media based on their likings (To et al., 2007). Information about customized advertisements was derived from the answers of respondents when asked to rate the following:

1. I find that through information from my profile on social media websites, I am presented with advertisements for products or services that are more compatible with my preferences.
2. Products presented to me on social media platforms are customized to my tastes.
3. Product or service recommendations on social media websites make me feel like an important customer.

**Trend Discovery (TD)**

Social media sites can provide the latest information about new trends and fashions (To et al., 2007). To assess trend discovery, respondents were asked to rate the following:

1. Social media provides a great platform to exchange information with my friends regarding products or services.
2. Through social media, I can be informed effectively and share my experience of newly purchased products or services with others.

**Socializing (S)**

Socializing is the ability to engage in a conversation (synchronous or asynchronous) with peers during the browsing of products on social media sites (To et al., 2007). In order to assess respondents' socializing habits, respondents were asked to rate the following:

1. Social media provides a great platform to exchange information with my friends regarding products or services.
2. I can make new friends with other shoppers through social media websites.

**Adventure (AD)**

## Chapter Four. Methodology and Research Plan

Adventure is the degree to which a social media site provides a novel and interesting browsing experience for users, and the sense of excitement that they get from using it (Mikalf et al., 2012). To assess socializing in the current study, respondents were asked to rate the following:

1. I find products or services through social media to be stimulating.
2. To me, finding products or services via social media websites is an adventure.
3. I get drawn into a world of my own when I find products or services on social media platforms.

### **Authority & Status (AS)**

Authority and status are the sense of authority that users of social media feel when browsing products (Mikalf et al., 2012). To assess authority and status, respondents will be asked to rate the following:

1. When I find products or services on social media websites, I feel that I am in control.
2. Through social media websites, I feel that I have good understanding of the products or services features that I find.
3. Social media enables me to control my browsing of products or services.

### **4.11.6 Online Shopping Intention (OSI)**

Online shopping intention is consumers' intention to purchase a product that they have seen on a social media website. To measure online shopping intention, respondents will be asked to rate the following (Mikalf et al., 2012):

1. When I need to buy a particular product or service, I search for a social media website that has the product or service.
2. I intend to buy products or services I see advertised on social media.
3. I intend to purchase online through social media sites in the near future.

#### **4.11.7 Shopping Orientations (SO)**

To examine these hypotheses, it is important to examine some variables first. In the case of this study as it relates to online shopping, the variables identified included home orientation, mall orientation, economic orientation, recreational orientation, personalizing orientation and ethical orientation. The literature explains the relationship between each of these orientations and the intent to shop online. Home shopping orientation implies the desire by a shopper to purchase all they need from the comfort of their home. This type of shopper prefers to purchase all they need from home because it saves them costs and time. Besides, they prefer it because they can access a wide variety of products at good prices from the comfort of their home (Vijayasathy, 2002).

The literature elucidates that the shoppers who prefer to shop from home are likely to have experience with shopping modes such as TV shopping and mail order catalogues. Therefore, due to the similarity between these modes and Internet shopping, it is presumable that this group of customers will have a positive intention to shop online. By contrast, mall shopping orientation inspires shoppers to shop in centres with malls. Such customers prefer malls because they offer a wide variety of stores within which they can procure all types of products in one trip. Therefore, the expectation is that this type of customer will have low intent to shop online (Lee & Lings, 2008).

Consequently, a shopper with an economic orientation is one who shops based on variables such as price and quality. This type of shopper may try to find many options that offer them value for their money on the products and services they decide to procure (Vijayasathy, 2002). Therefore, customers who have an economic shopping orientation tend to have a positive intent to shop online, because the Internet is rich in information on products that assists them in making the most optimal decision regarding what to purchase and at what price (Paden & Stell, 2000).

Recreational online shopping intent is subject to the definition of ‘recreation’. In the interest of this study, ‘recreation’ will be used to describe social activities in the physical

## Chapter Four. Methodology and Research Plan

world. It is important to establish this definition because online activities such as chatting and browsing could arguably qualify as recreational activities as well. Therefore, this type of shopper enjoys going out to places where they interact with family, friends and even create new friends and hobbies (Paden & Stell, 2000).

Therefore, based on the definition of 'recreation' used in this study, such shoppers may not find recreation online and thus are less likely to have the intention of online shopping. In addition, shoppers with a personalizing or ethical orientation tend to have a low preference for online shopping. Personalizing oriented shoppers prefer to be in contact with salespersons, but Internet shopping is impersonal. For ethically oriented shoppers, it is vital to ensure that they make a purchase from an individual who is affiliated with the local community, an aspect that tends not to be present in online shopping (Lee & Lings, 2008).

Intention to use online shopping is expected to have a positive relationship with economic and home shopping orientation. Conversely, it is expected to have a negative relationship with mall, personalizing and ethical shopping orientations (Vijayasathy, 2002). In order to test these hypotheses, respondents will be asked to rate the following:

1. I like to shop using mail order catalogues, TV or the Internet.
2. I shop online because I cannot find what I want in local stores.
3. Shopping online is more convenient than going to the store.
4. I can save a lot of money by shopping online.
5. I like to read a great deal of information on social media sites before buying products or services online.



## Chapter Four. Methodology and Research Plan

Table 4-7. Construct measurement adopted from Mikalef et al., 2012; Zhou et al., 2007; Vijayasathy, 2002.

Construct	Item
<b>Online shopping</b>	OS 1: I feel comfortable when using social media sites to purchase online. OS2: I feel that social media sites are easy to use when I purchase online.
<b>Online shopping experience</b>	OE1: I am experienced in purchasing online through social media sites. OE2: I feel competent in using the social media sites when I purchase online.
<b>Social Media</b>	SM1: Social media provides a wonderful means to find products or services online. SM2: I use social media to browse products or services on company-hosted pages when I am online. SM3: I will continue browsing through products and services online via social media websites in the future.
<b>Convenience</b>	CO1: Social media websites are a convenient medium since they enable me to find products or services whenever I want. CO2: It is convenient to find products or services through social media since I can do so from the comfort of my own home. CO3: Through social media, I can find products or services at my convenience.
<b>Information Availability</b>	IA1: Social media provides me quick access to large volumes of information about products or services. IA2: I can collect useful information about products or services I want through social media websites. IA3: Comments by other users of social media websites help by giving me feedback about the products or services advertised.
<b>Product Selection</b>	PS1: Social media helps me find products or services that I was unfamiliar with. PS2: I can find a wide selection of products or services on one website through social media. PS3: With social media, I can browse through a large array of products or services.
<b>Customized Advertisements</b>	CA1: I find that through information from my profile on social media websites, I am presented with ads for products or services that are more compatible with my likings. CA2: Products or services presented to me on social media platforms are customized to my tastes. CA3: Product or service recommendations on social media websites make me feel like an important customer.
<b>Trend Discovery</b>	TD1: Social media provides a great platform to exchange information with my friends regarding products or services.

	TD2: Through social media, I can be informed and effectively share my experience of newly purchased products or services with others.
<b>Socializing</b>	SO 1: Social media provides a great platform to exchange information with my friends regarding products or services. SO 2: I can make new friends with other shoppers through social media websites.
<b>Adventure</b>	AD1: I find products or services through social media to be stimulating. AD2: To me, finding products or services via social media websites is an adventure. AD3: I get drawn into a world of my own when I find products or services on social media platforms.
<b>Authority &amp; Status</b>	AS1: When I find products or services on social media websites, I feel I am in control. AS2: Through social media websites, I feel that I have a good understanding of the features of the products or services that I find. AS3: Social media enables me to control my browsing of products or services.
<b>Online Shopping Intention</b>	OSI 1: When I need to buy a particular product or service, I intend to search for a social media website that has the product or service. OSI 2: I intend to buy products or services I see advertised on social media. OSI 3: I intend to purchase online through social media sites in the near future.
<b>Shopping Orientations</b>	SO 1: I like to shop from home (e.g., mail order catalogue, TV or Internet). SO 2: I shop online because I cannot find what I want in local stores. SO 3: Shopping online is more convenient than going to the store. SO 4: I can save a lot of money by shopping online. SO 5: I like to read a great deal of information on social media sites before buying products or services online.

### 4.12 Sampling

There are two kinds of sampling technique—probability sampling and non-probability sampling. Probability sampling, also referred to as ‘representative sampling’, is used in research with strategies that are survey-based since it derives inferences from the used sample that is identified, in accordance with a population used in providing answers of the question(s) of research. Probability sampling identifies a non-zero opportunity adhering to the selection of every population element (Bryman, 2012). Bryman and Bell (2011), recognize four kinds of probability sampling—systematic sampling, multi-stage cluster sampling, simple random sampling and stratified random sampling.

Random sampling is limited by the type of sampling known as non-probability. Non-probability sampling gives a range of alternative techniques that enable sample selection based on one's subjective judgment. In the exploratory stages of some studies, like a pilot survey, the sampling is highly applicable though it may constrict the extent of the problem to be determined. In accordance with Bryman and Bell (2011), non-probability sampling can be classified as convenience sampling, quota sampling or snowball sampling, which has been employed in this research.

### **4.12.1 Sample Design**

A mixed process is employed in the sampling unit selection. A mixed process includes distribution of surveys online along with distribution of surveys to individuals and to online shoppers. The population selected for this study involves online shoppers, particularly those who utilize social media for their shopping. As previously recognized, it adds a random sampling technique, whereby the sample is chosen to target online shoppers by utilizing online surveys and distributing questionnaires to the general public in Saudi Arabia. The objective of using a mixture of three processes is to enable empirical data collection to be on-time and random, as the thesis identifies the importance of maintaining resources and time (Bryman & Bell 2011). This thesis will issue the questionnaire in various areas, such as different industries and population distributions.

### **4.12.2 Sample Size**

Many management and business studies have employed estimations with relation to the characteristics of the population at 95% plus or minus 3-5% of its true value (see Table 4.8). This specifies that if 45% is in a certain category, the research findings will have 95% certainty. This shows that the whole or total population in a similar group will be 45% plus or minus a margin of error, thus 42-48% for a 3% error margin (Bryman, 2012). Here are the main terms that need to be recognized by those carrying out the research in order to complete the calculation of their sample size:

## Chapter Four. Methodology and Research Plan

**Population size:** the total number of individuals a researcher is attempting to contact with his or her survey. If a researcher is carrying out a random sample of people in the US, the population size will be around 317 million. Similarly, if the researcher is doing a survey in his or her company, the population size will be the sum of all employees.

**Margin of error:** a given percent that describes how accurately a sample can yield the “true value”. The researcher is usually very close to obtaining an exact answer at a particular confidence level, as the error of margin gets smaller.

**Confidence level:** a measure of how accurately a particular sample reflects the population, within its margin of error. Standards commonly utilized by researchers are 99%, 95% and 90% (see Table 4.8 for more).

$$\text{Sample size} = \frac{\frac{z^2 \times p(1-p)}{e^2}}{1 + \left(\frac{z^2 \times p(1-p)}{e^2 n}\right)}$$

The Z-score is the amount of standard deviations that separates a provided proportion from the mean.

## Chapter Four. Methodology and Research Plan

To determine which Z-score to utilize, check the table below:

**Table 4-8. Z-score**

Confidence level	Z-score
80%	1.28
85%	1.44
90%	1.65
95%	1.96
99%	2.58

**Table 4-9. Sample size for different population sizes adapted from Saunders et al., 2009**

Population	Margin of Error			
	5%	3%	2%	1%
50	44	48	49	50
1,000	278	516	706	906
10,000	370	964	1936	4899
100,000	383	1056	2345	8762
1,000,000	384	1066	2395	9513
10,000,000	384	1067	2400	9595

## Chapter Four. Methodology and Research Plan

As seen in Table 4.8, there are 29,994,272 people living in Saudi Arabia, but only 15,800,000 are Internet users; however, 39% use online shopping in Saudi Arabia, which equals 6,162,000 people. Also, according to Social Clint (2013), there are 7.8 million users of social media.

The smaller the sample absolute size, and—to a much smaller extent—the lesser the relative proportion of the sum population sampled, the larger the margin of error. This enhances the margin of error that can be realized. In this context, the effect of absolute sample size on the margin of error declines for greater sample sizes. The sample size is approximately 385 people; however, the samples may not identify a 100% response rate, thus necessitating the incorporation of a bigger sample to ensure adequate responses for the margin of error needed. As seen in the equations for the minimum sample required, more than 1,500 surveys need to be distributed in order to identify responses from at least 25% of the surveys.

## Chapter Four. Methodology and Research Plan

**Table 4-10.** Sampling. Source: Central Department Statistic and Information, Saudi Arabia, 2014, Communications and Information Technology Commission of Saudi Arabia 2014

Internet Users	15,800,000 Internet users	
Online Shoppers	6,162,000 Internet users in the country use online shopping	39%
Social Media	7,800,000 social media users	49%

$$n = \frac{t^2 \times p^2}{m^2}$$

Where:

n = required sample size

t = 95% confidence level (standard value of 1.96)

p = estimated fractional population (39%)

Confidence Level 95%

m = margin of error at 5% (standard value of 0.05)

Therefore, minimum sample size (n) = 385

$$n^a = \frac{n \times 100}{re\%}$$

Where:

n<sup>a</sup> = actual sample size required

n = minimum sample

Re% = estimated response rate expressed as a percentage

Therefore, actual sample size required n<sup>a</sup> = 1,540

### **4.12.3 Sampling and Generalization**

The inability to draw a probability sample of Internet users is the biggest issue for any study using online methods. The reason why a probability sample is currently impossible in this study is that there is no complete list of the e-mail addresses of Internet users who have purchased online (Bryman, 2012). Since the sampling frame is restricted to people who have made such purchases and are registered within a specific organization (i.e., the response panel), there is no way to know how many people are actually excluded from the survey. Without the ability to draw a random sample, this study cannot declare the results to be generalizable to the entire population of Saudi online shoppers.

Another related issue is that it is an ethical obligation in research to use population samples comprised of all income levels, races, levels of education and gender in conducting their surveys. Individuals who are able to access modems, Internet and personal computers are not necessarily representative of the population as a whole.

As the nature of this study is to obtain responses from existing online shoppers who use social media, the sample should be drawn from people who have already at least one social media account. To ensure the representativeness of the sample, survey invitations were sent through Facebook, Twitter and Instagram. Evidence of the representativeness of the sample is shown by the descriptive analysis and profiles of respondents in Chapter 5.

### **4.13 Data Types**

Research in the social sciences incorporates two key types of data source: primary and secondary. According to Malhotra (2007), primary data is collected to address specific problem(s) of the research. Secondary data is comprised of data from previous research (Saunders et al., 2009). Secondary data is meaningful as it enables valuable insights into the field and helps develop a foundation from which to generate more ideas (Malhotra, 2007).



On the other hand, the collection of secondary data may not be needed. There may be no information existent that would bear direct relevance to the research questions. In addition, it is time-consuming to publish material; hence, the data might be out of date and hence losing its relevance to the research. This, therefore, highlights a strong concern for a study retrieved from the Internet, as it is rapidly undergoing change due to the continuous incorporation of technological innovations and ever-changing trends, which influence the activities of online shopping.

According to Easterby-Smith et al., (2008) primary and secondary data can complement one another efficiently and effectively. Hence, this study employs the use of both primary (online surveys) and secondary data (literature review).

### **4.14 Data Collection**

The University of Salford's ethical policy obligates researchers to apply for ethical approval before conducting field studies. Cooper and Schindler (2008) define research ethics as the "behaviour standards or norms that gives guidance on moral choices about behaviour of researchers and how they relate with others." The study has to uphold these standards.

This paper is intended for the core literature, and at the same time the researcher will conduct any other relevant processes that must be completed as part of the PhD requirements. In particular, the University's Ethical Approval was obtained (see Appendix 2). During the initial week of data collection, a link to the survey was displayed on the researchers' Facebook account. This post worked well to solicit participation in the survey. Approximately 20 users completed the survey in the first day. During the first week alone, almost 150 respondents participated without any email or other social media site solicitation.

By week two, the participation levels started to lag, so an Instagram message was sent out to prompt further participation. This resulted in an immediate escalation of responses on that day, attracting over 150 additional respondents within two days. However, the researcher's page at Twitter is going to be posted.

### 4.15 Data Error

With any study or sample, a researcher must be aware of potential sources of error. Bryman and Bell (2011) highlighted four types of possible error—errors of data collection, errors of sampling, errors of data processing, and sampling-related error (see Table 4.10). The former two sources are associated with sampling, whereas the latter two are not.

Webb (2002) took a less specific approach to sources of error, distinguishing more simply between sampling and non-sampling error. Webb (2002) defines sampling error as that associated with selecting a probability sample which is not representative of the population, whereas non-sampling error includes all other errors that are not sampling-related (which can reduce accuracy and validity). Increasing the sample size will decrease sampling error, though it might also increase non-sampling error.

Non-sampling error is much more of a problem in a research project than sampling error, because it cannot be estimated (Webb et al., 2001). No method will ever be perfect, so sources of non-sampling error are continually being found, making it more pervasive and harder to pinpoint (Webb et al., 2001). Non-sampling error has been divided into categories by Webb et al. (2001), including non-coverage (i.e., omitting areas of survey population), non-response, field (i.e., incorrect answers or refusals) and office (i.e., coding, tabulating, administration).

**Table 4-11.** Data error adapted from Saunders et al., 2009

Type of Error	
Sampling	The difference between the sample and the population from which it was selected, using probability sampling.
Non-sampling	The difference between sample and population deriving from insufficiency in the sampling approach.
Data collection	Involves the implementation of the research process, such as weak wording of questions or flaws in the management of research instruments.
Processing of data	Originates from defective management of data, specifically in the coding of answers.

### **4.16 Data Analysis**

Data analysis occurs after the collection of raw data from the market, and this process converts the latter into information. This information is then used to achieve the aim of the research and any quantitative data analysis. The quantitative data will then be analysed through the assistance of analysis tools such as SPSS.

Kinnear and Taylor (1991) suggest three basic guidelines in a trial to ascertain the most appropriate statistical technique for adoption.

1. How many variables will be analysed at the same time?
2. Does the researcher want to address description or inference questions?
3. In regard to the variable of interest, what levels of measurement (nominal, ordinal, and interval) are available?

In general, univariate data analysis involves the analysis of only one variable at a time, while bivariate data analysis investigates the relationship between two variables. Investigating the relationships among more than two variables at a time is known as multivariate data analysis. In the present study, a combination of the above statistical analysis is employed.

#### **4.16.1 Descriptive Statistics**

Descriptive statistics is a branch of statistics that uses numerical and graphic techniques to summarize data collection in a way that is clear and simple to understand. This is the reverse of inferential statistics, which aims to draw inferences about a population based on a representative sample. Descriptive statistics are useful in analysing large amounts of data to provide a simple summary. Descriptive statistics are divided into two broad categories—numerical and graphical methods. Numerical methods compute statistics such as the mode, standard and mean deviation, which are instrumental in offering an overview of the average and distribution of the data. Graphical methods are the preferred choice when identifying

## Chapter Four. Methodology and Research Plan

patterns or trends in a collection of data (Cole et al., 2003). However, both types of statistics complement each other and should be used together for best results.

Descriptive statistics examine three major features of a variable—distribution, central tendency and dispersion (Loether & McTavish, 1974). Distribution summarizes the frequency of a value or range of values for a particular variable. The most common way of describing a variable is through a frequency distribution. A frequency distribution organizes raw data into grouped and ungrouped data. Grouped data combines all values into classes and then indicates how frequent a value occurs in each class. Ungrouped data, on the other hand, provides a listing of all values and indicates the frequency of occurrence of each value.

Central tendency is a way of estimating the centre of a distribution of values. Central tendency has three key types of estimates—the mean, median and mode. The average value is the most common measure of central tendency. The median refers to the number or value that is in the middle when all values are arranged in numerical order, while the mode is the number that appears most frequently in the dataset (Healey, 2012).

Even though the most commonly utilized measure of central tendency is the mean, it has one major disadvantage. Unlike the other two measures, the mean can be influenced greatly by outliers (i.e., extreme data points). However, depending on the intention of the research, any of the three can be appropriate. For instance, if the study is looking to identify the dominant ethnic community in a location, the mode will be the best choice among the three.

Using central tendency alone cannot give a complete picture of the frequency distribution, specifically with regards to how scattered the values are within a certain distribution (Healey, 2012). Dispersion is used in such a case, since it measures how widely values in a distribution diverge from the average. This way, a researcher can ascertain the uniformity or consistency of certain data, because even though two datasets may have the same average, their values may be spread out across a wide range or clustered tightly together.

Measures of dispersion are inclusive of the range, standard deviation, mean deviation and quartile deviation. The range is simply the diversity between the highest and lowest values, while the standard deviation indicates the relation between the set of values and the sample

mean. Mean deviation is the average of the deviations of each value from the average of the sample. A commonly used measure of dispersion is standard deviation (Healey, 2012).

### **4.16.1.1 Mean Scores**

Probably the most often utilized descriptive statistics is the mean, which is similar to the average score of the numbers. The mean can be utilized in all kinds of statistical analyses and mathematical manipulations like the t-test. Specifically, the mean is an informative measure of the central tendency of the variable if it is reported with its intervals of confidence.

### **4.16.2 Reliability Analysis**

This analysis is completed after the descriptive analysis stage. Since this approach accurately describes certain parts of reality, it is considered to be associated with the positivist research philosophy with respect to quantitative research (Hanson & Grimmer, 2007). In cases when the study has been repeated, reliability becomes more about creating positive repetition of results in terms of quantitative data. Reliability has been defined by Malhotra and Birks (2007) in terms of quantitative data as the extent to which consistent results are produced by a scale, if the measurements are repeated on the characteristics.

According to Hawkins (1997), reliability is the absence of inconsistency causing random errors from the measures. This study used pilot testing to test questionnaires before implementing them. This allowed the elimination of any confusion and error from the questionnaire. Several other tests can be administered to establish the quality of a dataset. Table 4.11 shows some of these tests, such as test-retest reliability, alternative form reliability, internal consistency reliability and Cronbach's alpha (Malhotra & Birks, 2007).

**Table 4-12.** Reliability Test adapted from Fellows & Liu, 2008

Test	Description
T-test	Respondents are administered identical sets of scale items at two different times, under conditions as equivalent as possible
Alternative forms reliability	Requires two equivalent forms of the scale to be constructed, and then the same respondents are measured at two different times
Internal consistency reliability	An approach for assessing the internal consistency of a set of items, where several items are summated in order to form a total score for the scale
Cronbach's alpha	A measure of the internal consistency reliability, which is the average of all possible split-half coefficients resulting from different divisions of the scale items

### 4.16.3 Factor Analysis

A statistical set of techniques that are applied to model unmeasured variability in a dataset are all included in the factor analysis (Hoyle, 2000). The structure defining the set of variables is pointed out in the factor analysis (Hair et al., 2010), and the various interrelated measures are simplified into a particular order (Child, 1973). In cases where there is disorder, the results of the factor analysis are used to create order. A phenomenon can be observed and intellectual conclusions can be drawn in this manner. Malhotra and Birks (2007) have presented the steps that comprise the process of factor analysis (see Fig. 4.2). These are problem formulation, correlation matrix construction, and ascertaining the factor analysis method. Ascertaining the number of factors, factor loading, factor score calculation and eigenvalue. Exploratory and confirmatory factor analysis methods are used the most.

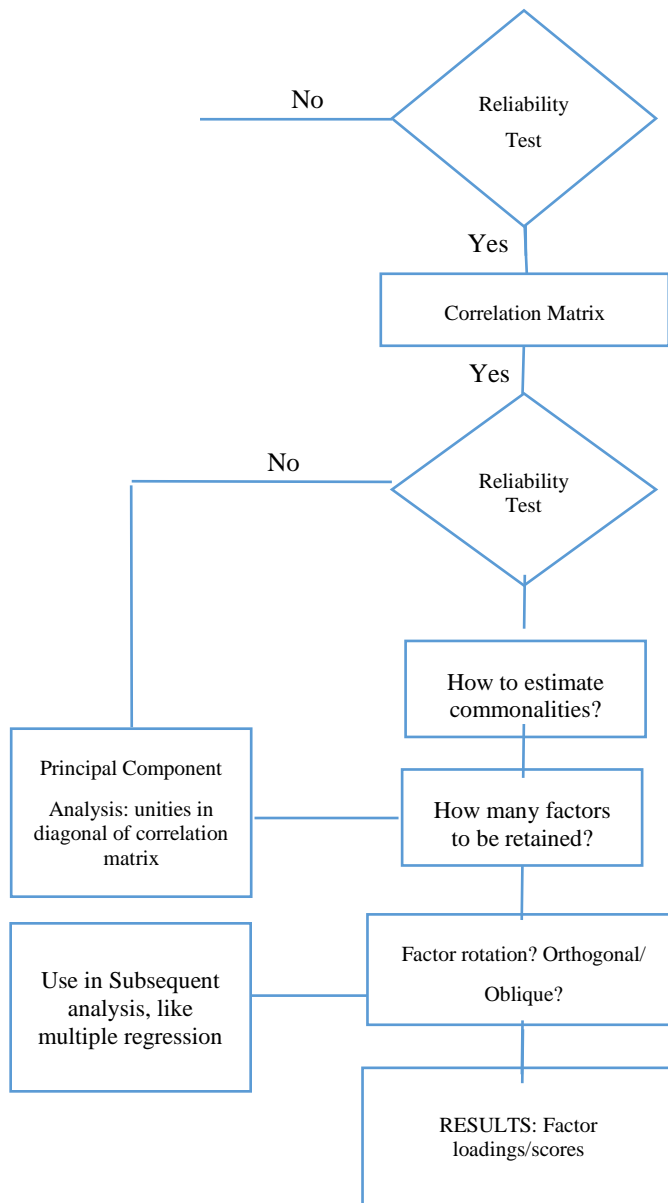

Figure 4-2. Steps of factor analysis adopted from Rietveld & Van Hout, 1993.

#### 4.16.4 Exploratory Factor Analysis

The underlying structure of a certain dataset is analysed in the exploratory factor analysis (EFA) method through the processes of reduction and summarization. This approach is a multivariate statistical technique (Malhotra & Birks, 2007). EFA can address a question in an inductive way or by uncovering the factors. This can be used as a contrasting approach.

## Chapter Four. Methodology and Research Plan

The correlation between a set of observed variables can be explored through the factor analysis method, which can also be used to determine whether these correlations are originated from their relationships to one or more latent constructs present in the dataset (Loarie et al., 2009).

The social sciences are immensely dependent upon these techniques (Costello & Osborne, 2011). When using the EFA, four primary factors that need to be considered – extraction, rotation, selection of factors in a solution, and sample size (Costello & Osborne, 2011). Inferential statistics are not used in the EFA. EFA should be specifically applied in the exploration of a dataset and the location of boundaries. These boundaries can then be further tested through confirmatory factor analysis. The two analytical methods will support each other. Table 4.11 shows the main statistics connected to the EFA.

**Table 4-13.** Key statistics associated with exploratory factor analysis adapted from Loarie et al., 2009

Test	Description
Bartlett's test of sphericity	Null hypothesis that the original correlation matrix is an identity matrix
Communality	Amount of variance that a variable shares with all other variables being considered
Correlation matrix	Calculating the correlations between each pair of variables
Eigenvalue	Total amount of variance explained by each factor
Factor loadings	Correlation of the original variable with a factor
Factor score	The scores of a subject on a (x) factor
Factor matrix	Contains all the factor loadings of all the variables on the factors extracted, equivalent term for a structure matrix
Kaiser-Meyer-Olkin (KMO) measure of sampling adequacy	An index used to examine the appropriateness of factor analysis (whether a dataset is factorable)
Screen plot	A graph that plots each factor in an analysis against its associated eigenvalue, which ultimately indicates the comparative importance of each factor



### **4.16.5 Confirmatory Factor Analysis**

The step following exploratory factor analysis is the confirmatory factor analysis (CFA), which enables an analyst to assess the degree to which the variables accurately denote the latent constructs being tested (Hair et al., 2010). The hypothesis, related to the unmeasured sources of variability responsible for similar aspects in a dataset, is tested through CFA (Hoyle, 2000). This analytical method is a deductive technique and can be used in cases where the latent variables are to some extent known (Byrne, 2010). In this case, some previous knowledge about the theory also exists. The analysis stipulates how the latent and observed constructs relate to each other, then examines them to ascertain their validity (Byrne, 2010).

A measurement model is constructed by using CFA (Byrne, 2010). Validating measurement model is the main aim of the CFA, since the without prior valid measurements no valid conclusions can be drawn (Hair et al., 2010).

It is imperative to meet the three basic requirements for the identification of a confirmatory model. The first requirements is to determine whether every factor has the three observed variables. The second is that no observed variable should behave as a part of more than one factor. And the third requirements is that there should be no relationship between the error terms. To ascertain whether a measurement model accurately denotes a dataset, the model fit statistics are used. The saturated model, sample size, independence model, Chi-square and degrees of freedom to output values of model fit (range 0-1) are all factors used for the calculation of the fit statistics (Schumacker & Lomax, 2004). The analyst will decide whether to reject or accept a model, although there are some acknowledged limits for these statistics.

CFA should be carried out prior to constructing a full latent model. Hypotheses can be tested by applying the CFA alone, although when used in combination with the full structural equation modelling (SEM), an analyst can gain further understanding of the process (Hoyle, 2000). Prior to accommodating a full structural model, the measurements of all the latent constructs in a study should be checked to determine whether they are

psychometrically sound or not (Byrne, 2010). The relationships between the measures of constructs, observed variables and latent factors are addressed by the CFA (Hoyle, 2000). When dealing with the relationships between the latent constructs, it is then that the structural model is used. Table 4.12 shows the primary statistics of a CFA.

**Table 4-14.** Key Statistics associated with CFA adapted from Hair et al. (2010)

Statistic	Description
Identification	Whether on the basis of the sample data contained in the sample covariance matrix or the theoretical model implied by the population covariance matrix, can a unique set of parameters be found?
Convergent validity	The extent to which indicators of a specific construct share a high proportion of variance
Discriminant validity	How truly distinct one construct is from other constructs
Measurement model	The part of a model that relates the measured variables to factors
Modification index	The amount that the model Chi-square value would decrease as a result of freezing any single particular path that has not yet been estimated
Parameter	Numerical representation of a characteristic of a population
Residuals	A value representing the discrepancy between the hypothesized model (or individual variables) and the observed data
Squared multiple correlations	A value representing the amount that a measured variable's variance is explained by a latent factor
Standardized residuals	The residuals of a model expressed in standard deviation units

#### 4.16.6 Exploring Relationships

The relationships among the constructs are studied through numerous statistical techniques, which also include the Chi-square test for independence, Spearman's rank

order correlation, Pearson's correlation multiple regression, canonical correlation and structural equation modelling (SEM). Hair et al. (2010) have evaluated the main objective of multivariate analysis. According to them, the measurement, explanation and prediction of the degree of the relationship among the variants are the main objectives of multivariate analysis.

### **4.16.7 Chi-Square Test for Independence**

When a relationship exists between two discrete constructs, the Chi-square test for independence is applied (Tabachnick & Fidell, 2007). The Chi-square test for independence is used in this case, as two categorical constructs are related (Loarie et al., 2009). The expected frequencies are created by the null hypothesis in the  $\chi^2$  analysis, which is used to test the observed frequencies in comparison. The value of  $\chi^2$  will be low when the frequencies observed are the same as the expected frequencies, while the null hypothesis is retained. The value of  $\chi^2$  will be high when the observed frequencies are different from the expected frequencies (Tabachnick & Fidell, 2007). The concept of the Chi-square test is based on the idea of conducting a comparison between the expected frequencies and the observed frequencies (Loarie et al., 2009).

### **4.16.8 Pearson Correlation**

The standardized strength measure of the relationship between two variables is termed the Pearson correlation (Loarie et al., 2009). The values range from -1 to +1. When a change in one variable causes the other variable to change in the opposite direction, then a value of -1 is obtained; however, when a change in one value causes the other value to change in the same direction, then the values of +1 are obtained (Loarie et al., 2009). Whether negative or positive, the Pearson correlation can indicate the direction of a relationship, while its absolute value will denote the strength of the connection between the variables (Pallant, 2007). The absence of a relationship between the two variables will be indicated by the correlation of 0 signals (Pallant, 2007).

#### **4.16.9 Spearman's Rank Order Correlation**

A Pearson's correlation that is non-parametric is Spearman's rank. This method is used to measure the amount of monotonic relationship between the two ordinal variables (Hardy & Bryman, 2010). A comparison between the rank orderings of respondents within the two 1.95 distributions is conducted by the Spearman's rho (Hardy & Bryman, 2010). The test performed by the Pearson's correlation is also done in the Spearman's rank. This method assesses the strength of the interrelationships between two variables. The significance measure is used to measure the output of this test. For instance, when there is a relationship between variables, then  $p < 0.5$ ; when the relationship is negligible, then  $p > 0.5$  (Loarie et al., 2009).

#### **4.16.10 Multiple Regression**

The main objective of multiple regression is to study causal relationships. The strength of these effects is reflected in these tests. In addition, it will help compare the strength of these effects across groups (Hardy & Bryman, 2010). The extent to which one dependent construct is related to a set of independent constructs is termed the multiple regression (Tabachnick & Fidell, 2007).

The prediction of dependent and independent constructs is the main focus of multiple regressions (Tabachnick & Fidell, 2007). The distributions that these constructs contain under hypothetical conditions are evaluated by describing the distribution of constructs. This is one of the uses of multiple regressions. The description of the distribution of the constructs is also used for modifying the observed differences to identify the effects of the confounding constructs. This would also help in determining important comparisons (Hardy & Bryman, 2010).

### **4.16.11 Canonical Correlation Analysis**

The relationship between two sets of constructs is measured by the canonical correlation (Pallant, 2007). The relationships between the two datasets are indicated by the canonical correlation, which in turn can be calculated directly from the data or from covariance matrices (Weenink, 2003). It is between two multidimensional constructs that a linear relationship is correlated. A value that is predicted in a test can be obtained by combining the sets of constructs on each side of the analysis. This predicted value has the strongest relationship with the predicted value on the other side (Tabachnick & Fidell, 2007). The dimension that connects the constructs on one side to those on the other will form a combination of constructs on each side (Tabachnick & Fidell, 2007). To achieve the highest correlation between both sets after transformation of these sets, the CCA looks for two linear transformations. The two latent constructs within two sets of measured constructs are used by the CCA in this manner (Dunteman, 1989).

### **4.16.12 Structural Equation Modelling (SEM)**

A collection of statistical techniques comprises structural equation modelling, which enables the existence of relationships between two or more independent variables. These relationships can be either discrete or continuous (Hair et al., 2010).

The field of psychology and social sciences made substantive use of SEM. The ability to use the methods of CFA provides researchers with a comprehensive way of modifying and analysing theoretical models, thus making this approach rather popular among researchers. Theoretical development can be further advanced on the grounds of this analytical method. The usage of a separate relationship for each set of dependent variables distinguishes SEM from other multivariate techniques (Hair et al., 2010). A range of different (separate), though independent, multiple-regression equations through SEM by specifying the structural model used in this statistical program.

Two factors of SEM have been studied by Byrne (2010). First, he studied a series of regression equations denoting the casual relationships in a study. Secondly, the theory studied is clearly depicted by graphically modelling the structural relationships.

SEM is undertaken through two approaches. In the first, it is confirmed whether the data fits the measurement model specified and measured during the CFA. Secondly, the EFA method through the reduction and summarization process. A full structural model is only specified after the measurement model has been confirmed. After that, the reliability can be rechecked. SEM needs to be over-identified or simply identified to ascertain that a certain data sample is sufficient (Schumacker & Lomax, 2004; Byrne, 2010). SEM is comprised of several basic steps (Schumacker & Lomax, 2004)

1. Model specification: a theoretical model is created
2. Model identification: it is ascertained whether a unique set of parameters exist in the sample data.
3. Model estimation: a fitting function is used to reduce the difference between the implied matrix.
4. Model testing: the extent to which data fits is ascertained.
5. Model modification: the new model is modified and analysed.

Kline (2011) provides a gist of the characteristics of SEM. According to Kline (2011), SEM should be regarded highly as it provides the additional benefits of flexibility and larger sample size, tests statistical significance, and explicitly represents the distinction between the observed and the latent constructs.

### **4.16.12.1 Advantage of SEM**

In comparison to conventional measured variable-only techniques like regression and multivariate-analysis, SEM renders numerous benefits. The relationships in the SEM are devoid of measurement errors as all the errors have been evaluated and eliminated prior to the study (Hair et al., 2010). Common variances are only left until the end. After the removal of measurement errors, it becomes easy to explicitly determine the reliability of

measurements within the analysis. Complicated relationships can also be studied through SEM. SEM emerges as the only analytical tool that gives space for simultaneous and complete tests of all relationships when multi-dimensional and complicated issues are involved.

### **4.17 Summary**

Chapter 3 provided a literature review pertaining to OSAM through the analysis of additional factors of social media use. This chapter gives a better understanding of the research methods utilized in the current study by providing an explanation of the procedures followed. The chosen research methods are well aligned with the study aims or objectives.

This research study has the following objectives:

- To understand online shopping acceptance through OSAM within Saudi Arabia.
- To understand the role of social media in online shopping acceptance in Saudi Arabia.

Various research methods were utilized to gather data pertaining to these objectives, including case studies, direct observation, questionnaires and interviews.

This study identified questionnaires as the most appropriate method for the following reasons:

- Questionnaires enhance the positive collection of well-defined quantitative data.
- The study of online shopping acceptance within Saudi Arabia integrated data gathered from many other countries. The locations identified collections of towns and suburbs spread over a broad area.
- In addition, methods that required actual visits to these towns and suburbs, such as interviews, were impractical and irrelevant to the study.

- The study needed data from a large group of consumers to identify an acceptable sample size for statistical analyses. The study established all the dependent and independent variables, thus identifying questionnaires as the ideal method. In addition, the questionnaire method enhanced the following:
  - a) Access to a large number of users.
  - b) Ability to gathering the most data within a limited amount of time.

The next two chapters present the findings from the descriptive and multivariate statistical analysis.



# **Chapter Five. ANALYSIS AND DISCUSSION (DESCRIPTIVE ANALYSIS)**

## **5.1 Chapter Overview**

The methods of this study were provided at length in the previous chapter. In this chapter, the conclusions drawn from the observations and the statistical tests from SPSS are described. The premise of this chapter is to investigate and to summarize the research previously completed. The data analysis is the key stage of this chapter where the data is assessed and then arranged in a concise manner. The formation of structure occurs in later stages by utilizing complex statistical methods of the analysis progression (Chatfield, 1985) like the Structural Equation Modeling (SEM) at the multivariate analysis level.

The first section in this chapter includes a detailed explanation of the observations obtained through this research. The demographic personality of the respondents that were used as a trial of Internet shoppers or the e-shoppers is illustrated through their given detailed information. The demographics of each are shown with the help of different methods that make them easier to evaluate like graphs, tables, and figures.

The second section addresses the moderation of the distribution and the conclusions drawn from the extensive analysis of the measurement scales for each constructs of the research. The next part includes the measurement scales for dependability and validity. It also contains the start-up multiple-regression analysis and its hypothesis depending on the theoretical outline made to check the link between the variables before the SEM analysis is carried out.

## **5.2 Descriptive Analysis**

Descriptive analysis is used to determine outcomes on the basis of variables or a series of variables without having to use theoretical ideas and then test them with hypothesizing (Tabachnick and Fidell (2007). The descriptive statistics are used to evaluate the characteristics of a sample (Pallant, 2007) or determine central tendencies (how data clusters around a value) (Tabachnick and Fidell, 2007). Other uses of the descriptive analysis include detecting a breach in the tasks that need to be executed for selected statistical techniques for a research like normality (Pallant, 2007). More uses of descriptive statistics as given in reference to Creswell, 2013; Pallant, 2007 are: the mean, medium, mode, frequencies, standard deviation, and skewness and kurtosis.

The inferential statistics are used together with the descriptive statistics in such a way that the descriptive statistics present the aspect of a data set (like socio-demographics or shopping frequencies) and set the plane for the inferences to give answers or relations. A comprehensive examination preceding the inferential data study was completed to check the frequencies and normality and to acquire a dependable explanation of the model.

## **5.3 Demographic Profile**

All the participants in the study were familiar with the concept of shopping through the web pages and as such, all of the participants had experience with e-shopping. The words ‘respondents’ means e-shoppers and hence both the words are used in the study.

The e-shoppers had to give their demographic data like age, gender, income, and education by going through a simple procedure of replying to multiple choice questions. The choices were created in the unexpected and expected scenarios with the unexpected ones further characterized into open-ended ones.

The results of the table 5.1 show that a greater number of e-shoppers are in 30-35 years (33.33%), after that in the ages 25 to 29 years (22.70%), and then in 18 to 24 years (17.97%). This means that a majority of the online shoppers are in the older ages or are in the middle ages between 25 and 35 years. There is additional research by Thamizhvanan & Xavier, 2013; Van Slyke et al., 2002, that examines the connection between the age

## Chapter Five. Analysis and Dissection (Descriptive Analysis)

group and their interest in the type of purchase they want to make. The conclusion reached here is that there is no specific age group that is more active with e-shopping than the other. In terms of gender, the table results show that there are less males than females involved in e-shopping. 33.57% are male and 66.43% are females, which clearly indicates that females are much more comfortable buying items online than the males. Some other researches also show the same result (El-Ansary & Roushdy, 2013; Fan & Miao, 2012; Thamizhvanan & Xavier, 2013). Regarding income, 30% of the respondents had salary range greater than 20,000 SR. The ones in a range of 8,001-12,000 SR income showed about 20.09%. This comparison is correct because it is in conjunction with other reviews that people with greater salaries are more likely to do to e-shopping than those with lesser salaries (Punj, 2011). The education level of the respondents also plays a role in e-shopping. The table shows that a large number of e-shoppers are professionals or graduates and among the respondents about 16.54% went to high school. We can say that mostly the e-shoppers are well-educated people, which is a similar finding of the other studies (Thamizhvanan & Xavier, 2013).

**Table 5-1** Demographic Characteristics

<b>Variables</b>	<b>Categories</b>	<b>%</b>	
N= 423			
<b>Gender</b>	Female	66.43%	281
	Male	33.57%	142
<b>Age</b>	18 or younger	0%	0
	18 – 24	17.97%	76
	25 – 29	22.70%	96
	30 – 35	33.33%	141
	36 -40	0%	0
	45 – 60	0%	0
	60 and above	26%	110
<b>Income</b>	2,000 and below	18.68%	79
	2,001 – 5,000	17.97	76
	5,001 – 8,000	12.77%	54
	8,001 – 12,000	20.09%	85
	12,001 – 15,000	0%	0
	15,001 – 20,000	0%	0
	20,001 and above	30.50%	129
<b>Education</b>	Did not attend school	0%	0
	Primary school	0.24%	1
	Elementary school	1.89%	8
	Secondary school	14.42%	61
	Bachelor degree	60.05%	254
	Master degree	17.97%	76
	PhD degree and above	5.44%	23

### 5.4 Internet Experience and Online Shopping

The respondents' shopping experience, the division of the products, and some associated online shopping with respect to the utilization of internet, searching frequency, purchase frequency, and types of Internet purchases are demonstrated in this part.

#### 5.4.1 Internet Usage

Tables 5.2 and 5.3 shows how long the responds have used the Internet. The table 19 shows the frequency of Internet use by the respondents in any ordinary day and the results show that around 50% of the e-shoppers are spending more than 4 hours a day using the social media. The outcomes also demonstrate that a large number of the e-shoppers (84.3%) were on the social media for more than 6 years. The respondents were skilled users of the internet for a long time and know how to fully utilize the social media offers. The research also found that the more successful transactions the user has made, the more likely he is to go for online shopping again and again (Brown et al. 2007; Yang et al., 2004). This research study also aligns with another study of Venkatesh and Morris (2000) which indicates that a person who uses a lot of internet is more likely to have positive behaviors towards the social media and its progression.

**Table 5-2** For how long have you been using the Internet?

		Percent	Valid Percent	Cumulative Percent
Valid	Less than 1 year	.5	.5	.5
	1 – 2 years	2.1	2.1	2.6
	3 – 4 years	4.9	4.9	7.5
	5 – 6 years	7.7	7.7	15.2
	more than 6 years	.5	.5	15.7
	Total	100.0	100.0	

**Table 5-3** In a typical day, roughly how much time do you spend using the Internet?

	Percent	Valid Percent	Cumulative Percent
Valid 0- 10 minutes	.7	.7	.7
11 – 30 minutes	3.0	3.0	3.7
31 minutes - 1 Hours	5.2	5.2	8.9
1- 2 Hours	14.5	14.5	23.4
2- 3 Hours	13.1	13.1	36.5
3- 4 hours and more	12.2	12.2	48.7
More than 4 hours	51.3	51.3	100.0
Total	100.0	100.0	

### 5.4.2 Internet Online Experience

The results of the online shopping done in a year are shown in table 5.4. The majority (59.8%) of the e-shoppers buy 1-5 things in a year, some (27.89%) buy 6-20 things in a year, while about 12.5% buy 21 or more things in a year through the Internet. The cumulative frequency of online shopping shows that only .12% of the e-shoppers shop regularly. There was an elevation in the frequency of online shoppers in the past 12 months.

Table 5.5 indicates the results of the amount spent by the e-shoppers. The majority (24.4%) of the e-shoppers spent about 501 to 2,000 SR per year, while only a small number of respondents (7.5%) spent 10,000 SR or more in a year.

These findings suggest that e-shoppers can be categorized as ‘frequent items’ who do a lot of online shopping, such as consumer; ‘ordinary shoppers’ who purchase more than 10,000 SR; and ‘occasional shoppers’ who spent for shopping online from 0 to 2,000 SR.

## Chapter Five. Analysis and Dissection (Descriptive Analysis)

**Table 5-4** How many approximately items have you purchased through Internet shopping for the last 12 months

		Percent	Valid Percent	Cumulative Percent
Valid	1-2 -	22.7	31.0	31.0
	3-5 -	20.4	27.8	58.8
	6-10 -	15.7	21.4	80.2
	11-20 -	5.4	7.3	87.5
	21 and above	9.1	12.5	100.0

**Table 5-5** how much have you spent on personal online purchases for the last 12 months

		Percent	Valid Percent	Cumulative Percent
Valid	SR 0 – 250	8.4	11.4	11.4
	SR 251 - 500	13.6	18.4	29.8
	SR 501 - 2,000.	24.4	33.0	62.9
	SR 2,001 – 5,000.	10.1	13.7	76.5
	SR 5,001 – 7,500.	5.9	7.9	84.4
	SR 7,501 – 10,000.	4.0	5.4	89.8
	SR 10,001 and more.	7.5	10.2	100.0
	Total	73.8	100.0	

### 5.4.3 Product Categories

The types of item bought online by the e-shoppers are shown in the figure 5.1. It shows the lists of all the product types that the e-shoppers purchased from the internet. A large number of the respondents claim to buy airline tickets (46.89%); Electronics/Mobile phones

## Chapter Five. Analysis and Dissection (Descriptive Analysis)

(30.75%); books (17.08%), and clothing/accessories/shoes (73.60%). The rest of the e-shoppers responded with ‘other items’ to indicate what they bought. However, it was found that car accessories and beauty products are the more popular products that were purchased. The Nielsen Global Consumer Report (2010) showed that the most popular items purchased on the Internet are as: books, clothing and accessories, shoes, airline ticket, electronic equipment and videos/ DVD/ games.

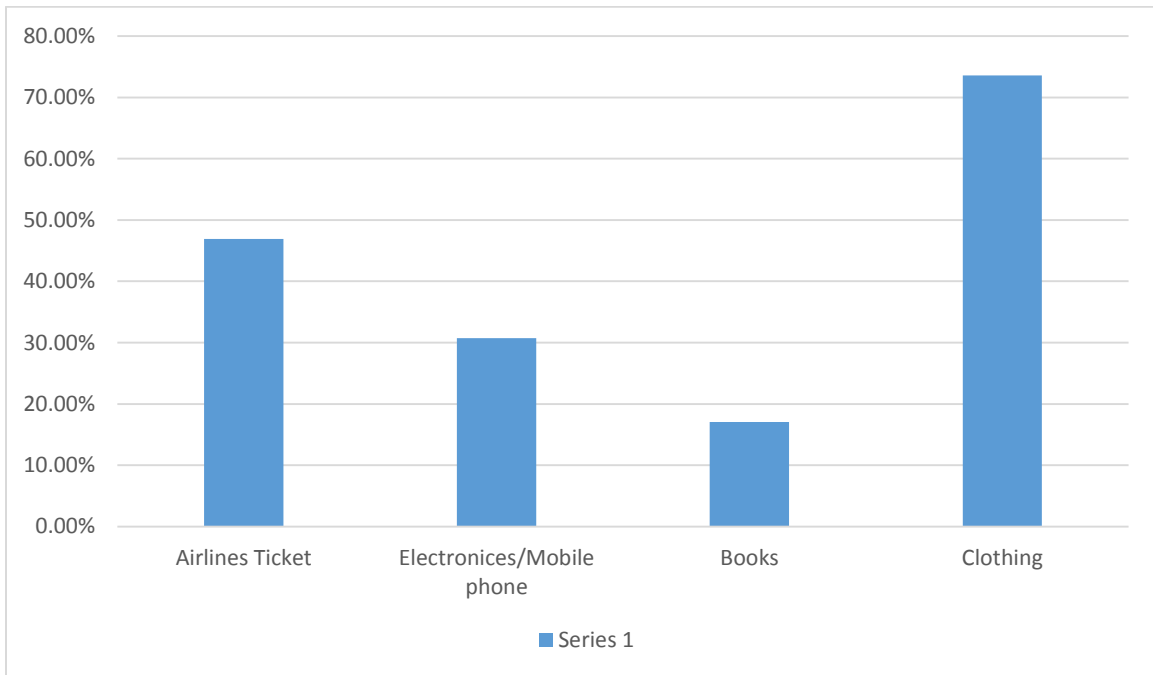

**Figure 5-1** Categories purchase online in the last 12 months



## 5.5 Social Media

This section shows the social media use or network. It particularly refers to the social media use in social networking through the frequencies of searches and purchases through the internet and the kinds of networks present.

### 5.5.1 Social Media Use

The figures 5.2 and 5.3 show the number of accounts the e-shoppers have on social media i.e. Facebook, Twitter and Google plus. About 57% have an account on YouTube and approximately 60% have an account on Facebook. In total, about 90.9% of users have accounts on social media websites.

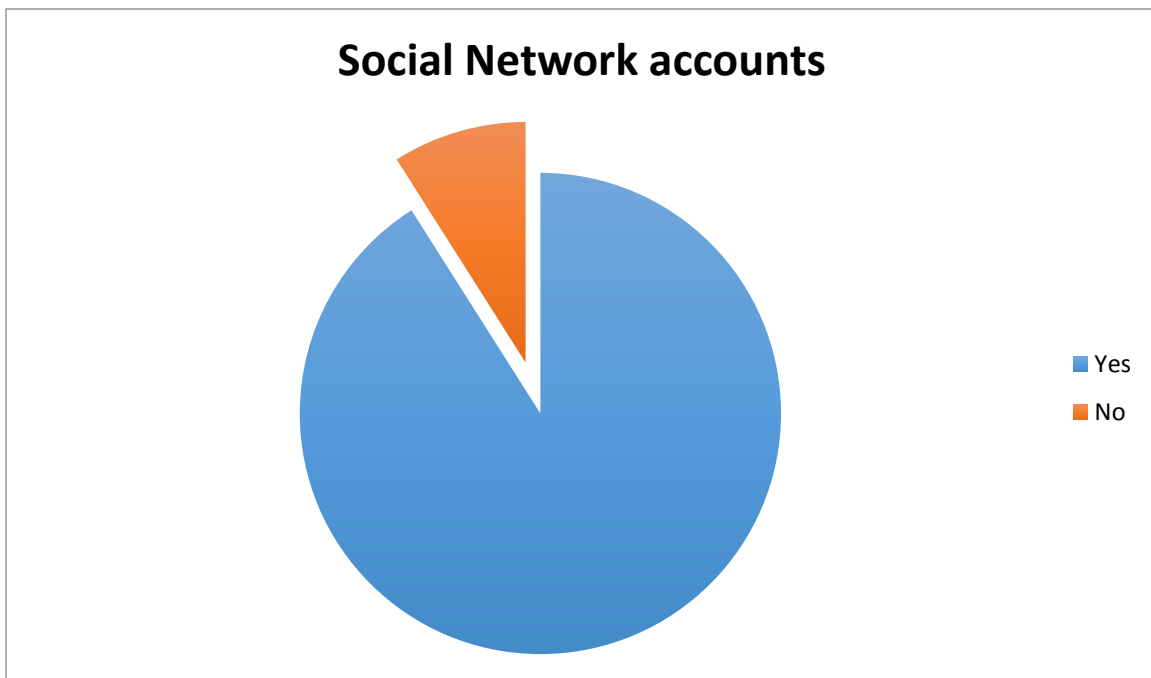

**Figure 5-2** Do you have any social network accounts?

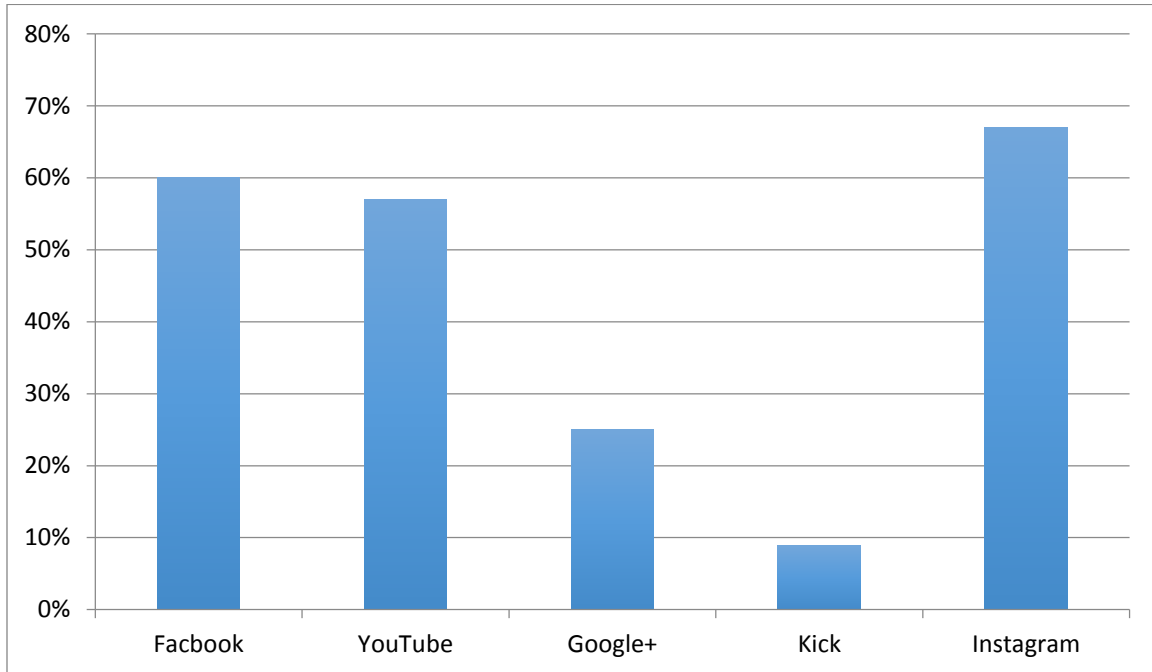
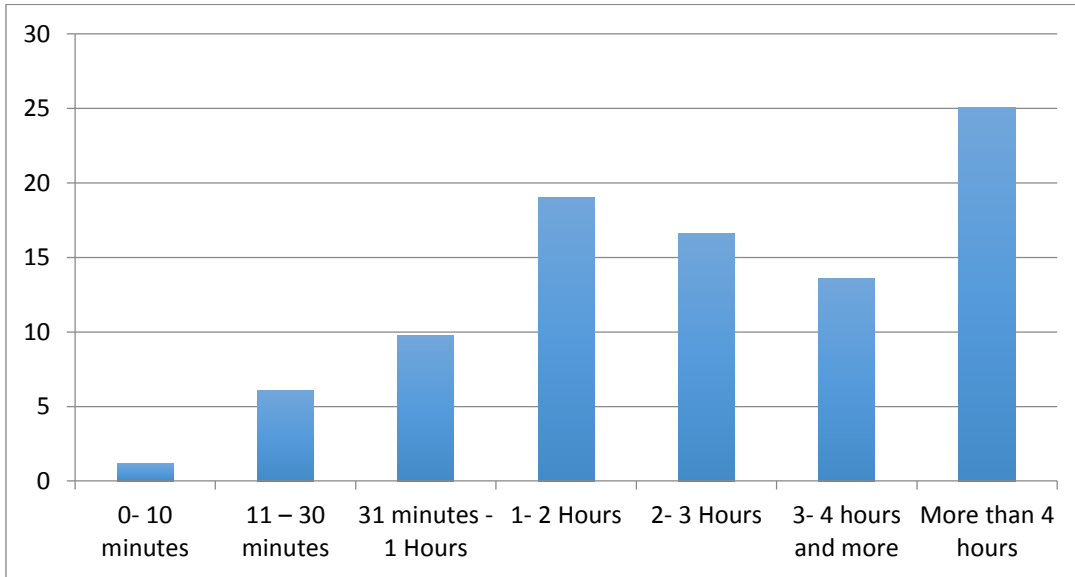

**Figure 5-3** Which social networking website do you most often use?

### 5.5.2 Social Media Usage

Figure 5.4 demonstrates how much time respondents spend using social media. The frequency of the respondents using internet is shown in figure 5.5. The results achieved say that a large number of e-shoppers (25.1%) spend about more than 4hours in a day on the social media. They also indicate that about 38% of the e-shoppers use the social media via their smart phones. This finding indicates that responders appear to be online consumers who are well versed, skillful with social media usage and technology. The results of this study are in accord with other findings that show the more time spent on the internet is directly related to more online shopping by those users. This is due to the fact that the person using the internet has easier access to the e-shopping stores than the ones not using it. The social media also gives the opportunity to people in promoting their items and goods services (Mikalef, et al., 2012).

## Chapter Five. Analysis and Dissection (Descriptive Analysis)



**Figure 5-4** how much time do you spend using social networking websites?

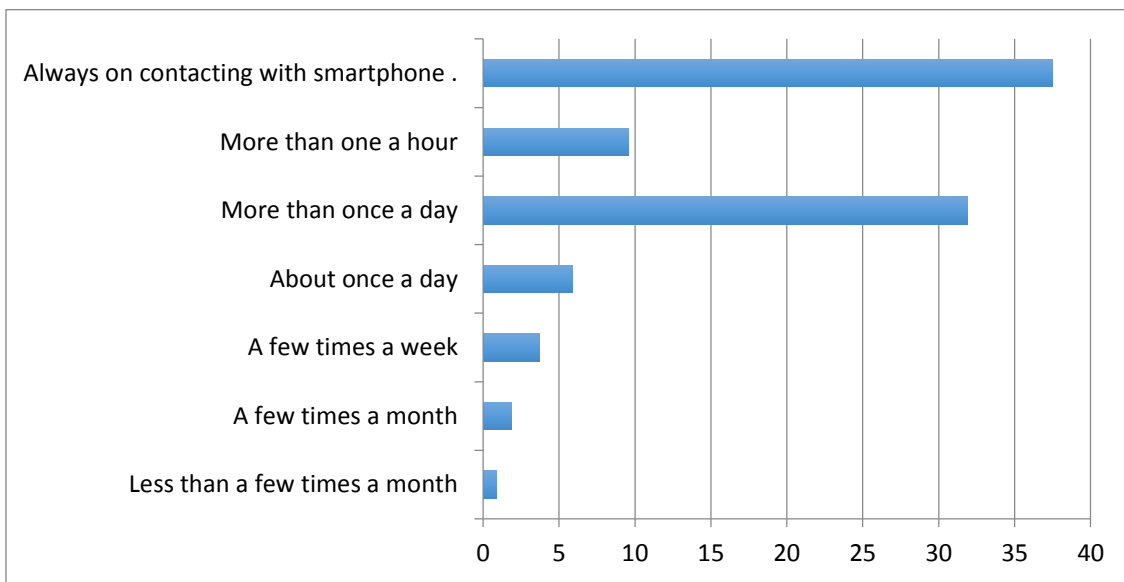

**Figure 5-5** How often do you log into social media networks?

### 5.5.3 Account of Social Media Used for Purchase Online

The most visited seven social media websites used for online shopping are shown in figure 5.6. The results show that Instagram is the most visited site for 57.4% of the online shoppers. The e-shoppers were found to have a particular choice and experience about where they want to buy their things. This finding indicates that responders appear to be online consumers who are well versed, skillful with social media account, especially Instagram account. Arno, in 2012, argued that more than 50% of the people currently using their smart phones have the ability to make purchases online through the social media websites like Twitter, Instagram, and Facebook.

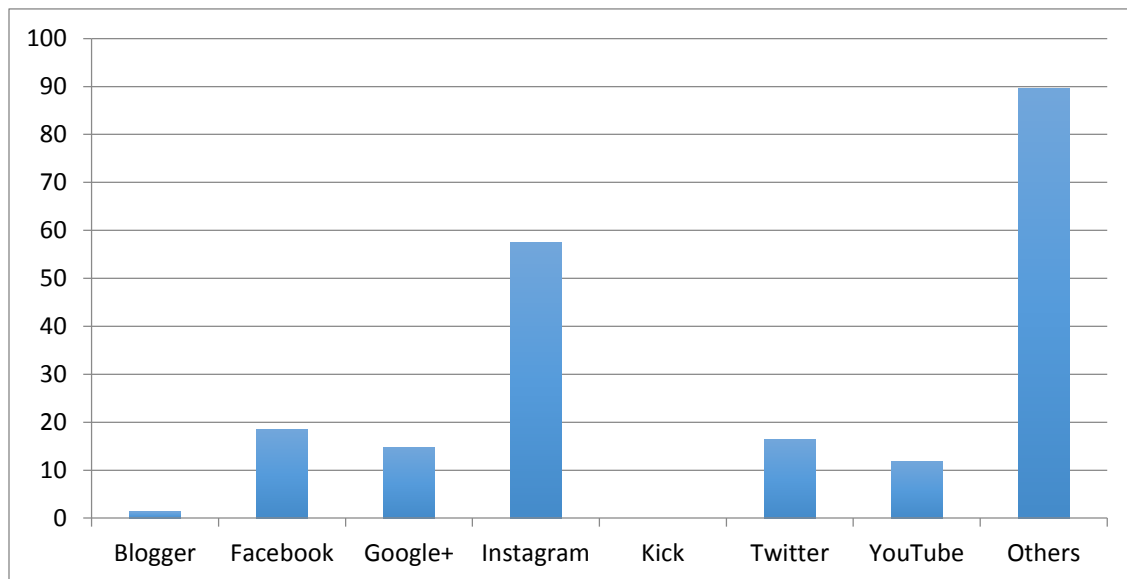

**Figure 5-6** Which social media websites have you used to shop or make decisions on regarding online shopping?

## 5.6 Descriptive Analysis of Measurement Scales

### 5.6.1 Result of Online Shopping (OS)

The measurement scale of the e-shopping has two parts that show the level of comfort the respondents are when shopping online. Table 5.6 shows the outcomes of the online shopping's' descriptive analysis. The e-shoppers were tested with questions that were

## Chapter Five. Analysis and Dissection (Descriptive Analysis)

interpreted using the seven-point Likert scales ranging from strongly disagree to strongly agree. Therefore, it can be said that the e-shoppers in this study exhibited relatively high agreement that online shopping is easy or comfortable to do. The people who use the Internet more easily are more likely to use e-shopping (Al-maghrabi and Dennis, 2010).

**Table 5-6** Measures of Online Shopping %

	1	2	3	4	5	6	7
<b>OS 1</b>	0	1.0	12.2	16.5	32.6	24.9	12.7
<b>OS 2</b>	.8	3.8	7.6	10.2	32.6	33.1	11.7

### 5.6.2 Result of Online Shopping Experience (OE)

The measurement scale of the e-shopping has two parts that show the level of respondents' comfort shopping online. Table 5.7 shows the outcomes of the online shopping descriptive analysis. The e-shoppers were tested with questions that were interpreted using the seven-point Likert scales ranging from strongly disagree to strongly agree. Therefore, it can be said that the e-shoppers in this study revealed relatively high agreement that e-shopping is easier and more convenient to do. The results of this research align with the results of other research, which claim that online purchases through social media websites is becoming easier. Additionally, online stores are making it even easier with greater access to their customers.

**Table 5-7** Measures of Online Experience %

	1	2	3	4	5	6	7
<b>OE 1</b>	0	.3	3.8	3.8	15.8	36.1	40.2
<b>OE 2</b>	.8	3.8	7.6	10.2	32.6	33.1	11.7

### 5.6.3 Result of Social Media (SM)

The measurement scale of e-shopping has two parts that show the level of comfort the respondents have when shopping online. Table 5.8 shows the outcomes of the online shopping descriptive analysis. The e-shoppers were tested with questions that were interpreted using the seven-point Likert scales ranging from strongly disagree to strongly agree. Therefore, we can say that the respondents in the research highly comply with the ease of online shopping and also with the fact that social media provides them with a nice service and a secure environment. This research has similar results with studies on the same subject that the social network keeps them up-to-date with other groups and helps them keep in touch with any progressing marketing plans and helps in giving greater profits in e-commerce sales.

**Table 5-8** Measures of Social Media %

	1	2	3	4	5	6	7
<b>SM 1</b>	.5	1.3	3.8	3.6	26.5	35.9	28.2
<b>SM 2</b>	0	1.8	4.8	5.9	19.1	40.5	28
<b>SM 3</b>	.3	3.6	2.5	7.5	17	32.6	36.4

### 5.6.4 Result of Online Shopping Intention (OSI)

The outcomes of the online shopping intention are shown in table 5.9. A seven-point Likert scale was used for the level of agreement just like in social OS, SM and OE was checked from a total of three things. Therefore, we can say that the respondents in the research perceive the ease of online shopping intention. The results match with the results of the preceding case where majority of the e-shoppers that have a social media account are more into the e-shopping trend. Most of the respondents tend to go to their favorite social media site for shopping online like Facebook or Twitter.

**Table 5-9** Measures of Online Shopping Intention %

	1	2	3	4	5	6	7
<b>OSI 1</b>	.8	2.8	6.9	1.0	24.7	37.4	26.5
<b>OSI 2</b>	.5	8.4	16	6.9	37.7	20.4	10.2
<b>OSI 3</b>	1.3	4.6	6.4	14.8	28.2	30.5	14.2

### 5.6.5 Result of Shopping Orientation (SO)

The outcomes of the online shopping orientation are shown in table 5.10. We use a seven-point Likert scale for the level of agreement just like in social OS, SM and OE was checked from a total of three things. The outcome demonstrates that the respondents have a significant orientation level even when they cannot get what they need from local shops and then go to online shopping in various unknown web stores. They mostly agreed with the SO1, SO2, SO3, SO4 and SO5. According to Zhou et al., (2007) the consumers inclination to buy items online was uniform among consumers with different shopping orientations (Brown et al. 2007). The online shoppers are provided a number of attractive offers by the e-commerce environments and as such, the customers are likely to decrease in getting used to online shopping between shoppers with different orientations.

**Table 5-10** Measures of Online Shopping Orientation %

	1	2	3	4	5	6	7
<b>SO 1</b>	2.3	8.7	8.9	6.1	29.0	24.9	20.1
<b>SO 2</b>	1.0	4.8	6.4	3.6	28.8	30.0	25.4
<b>SO 3</b>	1.8	12.2	9.2	5.9	35.1	22.1	13.7
<b>SO 4</b>	2.3	8.9	8.9	9.9	30.0	25.7	14.2
<b>SO 5</b>	.5	.8	2.8	4.1	18.6	39.9	33.3

### 5.6.6 Result of Online Shopping Motivation (M)

The motivation of online shopping is calculated through 8 sub types that consist of convenience (CO), information availability (IA), product selection (PS), customized advertisements (CA), trend discovery (TD), adventure (AD) and authority and status (AS). Preceding the analysis, the items in the scale were reverse-coded. The respondents were then supposed to select the level of agreement, from range 1 to 7, on items associated to hedonic motivation and utilitarian motivation. The table 5.11 demonstrates results that the measures online shopping motivation, for example that seemed satisfied with information availability(IA1) of the online shopping (M=6).

The respondents have shown significant motivation level for online shopping. This not provides convenience to purchase things but it is also imparting an enjoyable experience for shoppers to feel good while doing it. The motivation to enjoy the online shopping helps to make up for all the time that is spent while searching for the particular product on an e-store.



**Table 5-11** Measures of Online Shopping Motivation %

	1	2	3	4	5	6	7
<b>CO 1</b>	0.3	2.0	2.5	2.8	26.2	44.0	22.1
<b>CO 2</b>	.5	.8	2.8	3.8	23.2	45.5	23.4
<b>CO 3</b>	.3	.8	2.8	5.6	22.1	45.5	22.9
<b>IA 1</b>	.3	1.3	5.6	5.3	27.7	38.9	20.9
<b>IA 2</b>	.3	1.3	3.3	4.3	21.4	46.3	23.2
<b>IA3</b>	.3	1.5	2.5	4.1	21.4	43.0	27.2
<b>PS 1</b>	.3	.8	2.8	3.6	17.3	48.9	26.5
<b>PS 2</b>	.3	.5	2.8	5.3	20.6	46.8	23.7
<b>PS 3</b>	.3	.5	3.1	3.8	17.0	50.9	24.4
<b>CA 1</b>	1.5	4.6	7.1	14.2	21.1	35.9	15.5
<b>CA 2</b>	.3	.8	3.6	3.6	19.1	53.2	19.6
<b>CA 3</b>	.3	4.6	5.9	13.5	27.0	33.6	15.3
<b>TD 1</b>	.3	.8	3.6	4.8	23.2	48.9	18.6
<b>TD 2</b>	.3	1.3	4.1	6.4	20.4	45.5	22.1
<b>AD 1</b>	.5	.8	3.8	4.3	28.8	42.5	19.3
<b>AD 2</b>	.8	6.6	7.1	7.6	33.8	29.0	15.0
<b>AD 3</b>	.3	1.8	4.3	4.6	24.7	45.3	19.1
<b>AS 1</b>	.5	8.4	8.9	19.6	24.7	26.0	12.0
<b>AS 2</b>	.5	1.8	4.3	8.4	27.7	41.5	15.8
<b>AS 3</b>	.5	2.3	4.1	10.9	24.2	42.2	15.8

### **5.7 Summary**

The chapter began with the demographic profiles of the respondents. These profiles provided information about their history in context to the shopper's view about e-shopping. Most of the respondents that took part in the study high education, married but childless, belong to social media groups, and are middle aged.

The result was determined by the seven-point Likert scales for all the construct measures, which shows in the tables above that each of the construct must agree with the minimum level of acceptance of normality, skewness, and kurtosis. The results taken from the other variables show that most of the values are greater than the scales' mid-point which is 4.5. The results depict that the data are distributed closely around the mean and are uniform since majority of the standard deviations yield a value of less than 1.

The next chapter is data analysis that the measurements model fit which used determined the convergent validity and discriminate validity. The final step of next chapter, will used SEM for test hypotheses.

## **Chapter Six. DATA ANALYSIS II**

### **6.1 Chapter Overview**

The main Purpose of the previous chapter was to give the descriptive findings of the data while this chapter emphasizes the multivariate analysis' analytical process. In this case, the AMOS software will be used for the Structural Equation Modelling (SEM). The following sections are subdivided into two major parts which emphasize the structural model and the measurement model evaluation.

Based on SEM data analysis procedure presented, this chapter begins by recounting and explaining the analysis data preparation and screening steps which are composed of processes such as the detection of any outliers normality and missing data. The subsequent stage involves item purification measurement.

In addition, in order to validate the results with a procedure that is more accurate, they are subjected to a Confirmatory Factor Analysis (CFA) which will has been discussed into details in this chapter. Prior to CFA, all constructs in the study will be re-examined in terms of un-dimensionality, reliability, and validity utilizing SEM indicators.

The next section analyses the structural model, which is carried out by evaluating the general fit of the research model that was proposed. To achieve this, the chapter will establish the credibility of the hypothesized links amongst the dormant constructs.

### **6.2 Introduction**

The Structural Equation Modeling (SEM) is a very common multivariate method that is often used to simultaneously analyse various relationships (Byrne, 2010). The advantage of SEM over multiple regressions is defined by Hankins, French, and Horne (2000) as “multiple regressions is often applied to study the impact of a single variable and/or a set of independent variables on a single dependent variable, whilst the structural Equation Model examine complicated studies modelling several exogenous (independent) and several endogenous (dependent) variables.”

SEM is devoted to investigating two types of models of dimension and structure (Byrne, 2010). According to (Hair et al. 2010), a measuring model serves two purposes that include calculating dependability and indicators. Moreover (Byrne, 2010) pointed out that SEM uses CFA when employing the measuring model. Namely, CFA is a technique used for testing the measurement models. In contrast, the structural model is devoted to testing the hypothetical relationship among extracted factors and moderation variables. In this study, there is an interest to test the influence of observed variables known as moderating variables on the relationship between the underlying constructs. SEM was applied to examine the two models of study.

The technique of factor analysis is often utilized when investigating relationships between variables that are observed (items) and the interdependencies. The observed (measured) variables can be continuous or discrete (such variables measured on Likert scale). Since there are a number of latent variables (factors) that can be extracted from correlated observed variables, factor analysis aims to convert sets of observed variables that have similar patterns into fewer sets of latent (Fox, 1984). Thus, factor analysis is known as statistical reduction technique.

Assessment and testing of the model of interest were done using the SEM modeling through the path analysis and confirmatory factor analysis (CFA) techniques where CFA was the path analysis and measurement model were used to examine and test the hypotheses.

There are two main parts in this section: CFA results and hypothesis results. For CFA, model fit indices were examined that included validity and reliability of measurement model. Test of normality to justify using ML were also examined. In testing for the hypothesis, regression estimates were estimated using SEM.

Nine constructs with corresponding items were the basis of study model, see Table 6.1. For the measurement model given in Figure 6.1, thirteen constructs were selected in the study model to evaluate the use of Online Shopping Acceptance Model (OSAM): Online Shopping (OS), Online Shopping Experience (OE), Social Media (SM), Convenience (CO), Information Availability (IA), Product Selection (PS), Customized Advertisements (CA), Trend Discovery (TD), Socializing (S), Adventure (AD), Authority and Status (AS), Online Shopping Intention (OSI), Shopping orientations (SO).

Table 6-1 The Construct measurement Mikalef et al., 2012; Zhou *et al.* (2007); Vijayasarthi and Jones (2000)

Construct	Item
<b>Online Shopping</b> <b>OS</b>	OS 1: I feel comfortable when using the social media sites to purchase online. OS2: I feel that the social media sites are easy to use when I purchase online.
<b>Online Shopping Experience</b> <b>OE</b>	OE1: I am experienced in purchasing online with the use of the social media sites. OE2: I feel competent in using the social media sites when I purchase online.
<b>Social Media</b> <b>SM</b>	SM1: Social Media provide a wonderful means in order to find products or services online. SM2: I use Social Media to go through products or services on company hosted pages when I am online SM3: I will continue to browse through products and services online via Social Media websites in the future
<b>Convenience</b> <b>CO</b>	CO1: Social Media websites are a convenient medium since I can find products or services whenever I want to. CO2: It is convenient to find products or services through Social Media since I can do so in the comfort of my own space CO3: Through Social Media I can find products or services in accordance with my schedule
<b>Information Availability</b> <b>IA</b>	IA1: Social Media provide me with a quick access to large volumes of information about products or services IA2: I can collect useful information about products or services I want through Social Media websites IA3: Comments by other users of Social Media websites help in giving me feedback about a products or services advertised
<b>Product Selection</b> <b>PS</b>	PS1: Social Media help me find more products or services that I was unfamiliar with before PS2: I can find a wide selection of products or services in one website through Social Media PS3: With Social Media I can browse through a large array of products or services
<b>Customized Advertisements</b> <b>CA</b>	CA1: I find that through information from my profile on Social Media websites, I am presented with products or services advertisements that are more compatible with my likings CA2: Products or services presented to me on Social Media platforms are customized to my needs

## Chapter Six. Data Analysis II

	CA3: Products or services recommendations on Social Media websites make me feel as an important customer
<b>Trend Discovery</b> <b>TD</b>	TD1: Social Media provide a great platform in order to exchange information with my friends regarding products or services.  TD2: Through Social Media I can be informed and effectively share my experience of newly purchased products or services with others.
<b>Socializing</b> <b>S</b>	SO 1: Social Media provide a great platform to exchange information with my friends regarding products or services.  SO 2: I can make a new friend with other shoppers through Social Media websites
<b>Adventure</b> <b>AD</b>	AD1: I find products or services through Social Media to be stimulating  AD2: To me, finding products or services via Social Media websites is an adventure  AD3: I get drawn in to a world of my own when I find products or services on Social Media Platforms
<b>Authority &amp; Status</b> <b>AS</b>	AS1: When I find products or services on Social Media websites I feel I am in control  AS2: Through Social Media websites I feel that I have a good understanding on the products or services features which I find AS3: Social Media enable me to control my products or services browsing
<b>Online Shopping Intention</b> <b>OSI</b>	OSI 1: When I need to buy a particular product or service, I intend to search for a social media website which has the product or service.  OSI 2: I intend to buy products or services I see advertised on Social Media.  OSI 3: I intend to purchase online through social media sites in the near future.
<b>Shopping orientations</b> <b>SO</b>	SO 1: I like to shop from home (for example, using mail-order catalogues, the TV or the Internet).  SO 2: I shop online because I cannot find what I wanting local stores.  SO 3: Shopping online is more convenient than going to the store.  SO 4: I can save a lot of money by online shopping.  SO 5: I like to have a great deal of information on social media sites before I buy products or services online

### 6.3 The Measurement Model

The measurement model stipulates the methods used to measure the hypothetical constructs and the latent variables on the basis of the variables that are observed. The measurement model

## Chapter Six. Data Analysis II

in the SEM aims to evaluate and describe how the experimental indicators fit as an instrument used to measure for the variables that are latent. This is achieved by evaluating the dimensionality, reliability/consistency, and validity of the results or measurement properties. It is not effective to test and examine the structural model before assuring the measurement model is accurate and holds. The process of the measurement model commences with data preparation and screening.

### **6.3.1 Data Screening**

Kline (2011) provided two reasons why researchers focus on data screening and preparation before conducting an SEM analysis. First, the Structural Equation model requires specific assumptions about the dataset distributional characteristics that are employed for the SEM analysis. Secondly, problems that are linked to the data could be the cause of why fitting and model estimation programs fail to give results and solutions and at sometimes may be the basis of the program ‘crashing.’

According to Schafer and Graham (2002), the concern is significant about data that cannot be accounted for because it complicates scientific research. This is made worse by the fact that most data analysis procedures were not designed to account for the missing data. Consequently, the data that cannot be accounted for results to two major problems. These include: (1) the capacity of the statistical test to infer a connection or relationship in a dataset is significantly reduced and (2), the parameter estimates will be biased (Roth, 1994; De Vaus, 2001). However, as the research design of the present study employed an online survey, the missing data issue was addressed at the data collection stage. The online survey setting required the respondents to answer every question of the survey before submitting the results and this produced more accurate results in the data set and no values were reported to be missing.

Conducting SEM with a small sample size can possibly result in errors and wrong conclusions or assumptions. Model misspecification can affect parameter estimate accuracy. Schumacker and Lomax (2004) depicted that it is vital that a sufficient number of respondents or constructs in the chosen sample size to reduce chances of errors from occurring.

In James Steven’s book, “Applied Multivariate Statistics for the Social Sciences,” he explained that fifteen respondents are enough to make a good sample size where least squares multiple regression analysis is involved. This also happens when SEM is used. According to Hu and Bentler (1998) stated that often only five respondents can be approached when using the SEM

method when some circumstances are prevailing like adequate data and information on related issues. Loehlin (1992) emphasized that 100 cases or more, there should be two or four features. A good example is the simulation of Monte Carlo that implemented confirmatory factor analysis models. The using a less sample size of 200 with SEM can causes inaccuracy, erroneous solutions, and technical inadequacy because it is customized for sample sizes which are significantly larger.

Sample sizes that are large are more accurate where data is scarce. Uneven distribution of specific data calls for supplementary sample sizes. This enables a more accurate pool of information to be gathered without room for biased responses or unanswered questions, which may be a priority. This makes it difficult to achieve a better-informed decision.

Variables that are most dependent and mediated are found in SEM. These variables can also be referred to as downstream variables or endogenous. Practically, the assuming of continuity and the joint factor is never met. The importance of this method provide a bridge to the problem of inadequate data due to the nature of its scarcity. SEM method also mostly requires independent variables.

### **6.3.2. Exploratory Factor Analysis**

Fifteen variables related to the Online Shopping Experience (OE), Online Shopping (OS), Online Shopping Intention (OSI), Social Media (SM) and Shopping Orientations (SO) were considered to perform the first EFA. The researchers calculated the value of the Kaiser–Meyer–Olkin (KMO) measure of sampling adequacy, and its value (i.e. 0.876) was found suitable for factor analysis. Moreover, statistical significance (Sig. = 0.000) was attained using Bartlett’s test of sphericity, which indicated that the factor analysis has valued. Besides eliminating the variable having cross-loadings between factors, the variables with small factor weights (below 0.4) were excluded from.

The presence of five factors on 10 items was confirmed with the help of the maximum likelihood method. Approximately 70.03% total variance was obtained with these four factors.

An extremely clean factor structure is demonstrated by the pattern matrix (Table 6.3), wherein the high loadings within factors and no major cross-loadings between factors make the convergent and discriminant validity visible, clear cut and unambiguous. Checking the factor correlation matrix is the second method to observe if there is discriminant validity (see Table



## Chapter Six. Data Analysis II

6.4). Correlations should not go beyond 0.7, as we have seen in this example. The factor structure obtained in pattern matrix confirmed presence of five factors (Online shopping (OS), online shopping experience (OE), social media (SM), online shopping intention (OSI), and shopping orientations (SO).

**Table 6-2** Pattern Matrix

Name of factor		Factor					Communalities <sup>a</sup>	
		1	2	3	4	5	Initial	Extraction
Online Shopping	OS1	.958					0.51	0.83
	OS2	.612					0.48	0.54
Online Shopping Experience	OE1		.824				0.53	0.67
	OE2		.798				0.57	0.71
Social Media	SM1			.767			0.53	0.64
	SM2			.866			0.58	0.77
Shopping Orientation	SO1				.524		0.56	0.64
	SO3				.974		0.46	0.84
Online Shopping Intention	OSI2					.397	0.49	0.52
	OSI3					.923	0.58	0.83

Extraction Method: Maximum Likelihood.

Rotation Method: Promax with Kaiser

Normalization.

**Table 6-3** Factor Correlation Matrix

Factor	1	2	3	4	5

## Chapter Six. Data Analysis II

1	1.000	.556	.434	.557	.550
2	.556	1.000	.444	.515	.585
3	.434	.444	1.000	.457	.531
4	.557	.515	.457	1.000	.566
5	.550	.585	.531	.566	1.000

Extraction Method: Maximum Likelihood.

Rotation Method: Promax with Kaiser Normalization.

**The second EFA** was conducted over 20 variables related to Information Availability (IA), Convenience (CO), Customized Advertisements (CA), Product Selection (PS), Trend Discovery (TD), Authority and Status (AS), Socializing (S), and Adventure (AD). The value of the Kaiser-Meyer-Olkin Measure of Sampling Adequacy (KMO) was calculated and its value (0.965) indicated that the data was suitable for factor analysis. Also, Barlett's test of sphericity reached statistical significance (Sig. = 0.000), which indicated that the application of factor analysis is justified. With the aim to achieve discriminant and convergent validity of the scale, variables with a small factor weights (below 0.3) were excluded from further analysis as well as those that had cross-loadings between factors.

On sixteen items (table 6.5), maximum likelihood method confirmed the presence of four factors. These four factors obtained 72.5% of total variance explained. By reviewing scree plot (figure 6.2) and taking into account the Cattell (1966) criteria, all of four factors were retained for further analysis.

The factor structure obtained in pattern matrix confirmed presence of four factors ((Product Selection (PS), Information Availability (IA), Convenience (CO), and Authority and Status (AS).

Pattern matrix (table 6.6) illustrates a very clean factor structure in which convergent and discriminant validity are evident by the high loadings within factors and no major cross-loadings between factors. The second method to examine if there is discriminant validity was to check the factor correlation matrix, as shown below. Correlations between factors should not exceed 0.7, and that was exactly the case in this correlation matrix. Correlations above 0.7 indicates that there are discriminant validity issues, which can be fixed by doing second – order factor analysis when the measurement model were estimated.

**Table 6-4** Pattern Matrix

		Factor	Communalities
--	--	--------	---------------

## Chapter Six. Data Analysis II

Name of factor		Product Selection	Authority & Status	Convenience	Information Availability	Initial	Extraction
<b>Product Selection</b>	PS3_1	.915				.823	.872
<b>Customized Advertisements</b>	CA2_1	.828				.756	.786
<b>Product Selection</b>	PS2_1	.817				.779	.802
<b>Product Selection</b>	PS1_1	.659				.766	.771
<b>Trend Discovery</b>	TD1_1	.583	.306			.716	.734
<b>Information Availability</b>	IA3_1	.544				.646	.619
<b>Authority &amp; Status</b>	AS1_1		.830			.484	.570
<b>Customized Advertisements</b>	CA3_1		.655			.548	.573
<b>Authority &amp; Status</b>	AS3_1		.634			.660	.712
<b>Customized Advertisements</b>	CA1_1		.602			.421	.447
<b>Authority &amp; Status</b>	AS2_1		.474			.649	.673
<b>Convenience</b>	CO2_1			.907		.727	.819
<b>Convenience</b>	CO1_1			.722		.725	.768
<b>Convenience</b>	CO3_1			.586		.741	.766
<b>Information Availability</b>	IA2_1				.899	.782	.999
<b>Information Availability</b>	IA1_1				.439	.699	.689

Extraction Method: Maximum Likelihood.  
Rotation Method: Promax with Kaiser Normalization.

a. Rotation converged in 9 iterations.

**Table 6-5** Factor Correlation Matrix

Factor	1	2	3	4
1	1.000	.732	.792	.756
2	.732	1.000	.728	.641
3	.792	.728	1.000	.773
4	.756	.641	.773	1.000

Extraction Method: Maximum Likelihood.

Rotation Method: Promax with Kaiser Normalization.

### 6.3.3. Confirmatory Factor Analysis

According to Hair et al. (2010), the approach of the Confirmatory Factor Analysis is based on past information and understanding of various factors that have the corresponding number of items. Each set of items should highly on their latent factor (constructs). Using CFA, the researcher could assess the fit while exploratory factor analysis (EFA) does not (Ahire & Devaraj, 2001). The measurement model was examined through the application of CFA. Marsh et al., (1985) indicated that the importance of the concept are it assists in structuring strategy while doing research activities, it contains exceptional hypothesizes and exhibits reusable information which is employed in areas where there are similar concepts to determine accuracy. Through these advantages, CFA stood out in its effectiveness compared to exploratory factor analysis. Kline (2011) continued to support that CFA is better since it is used to test for both convergent and discriminant validity.

To confirm the factor structure carried out in the first exploratory factor analysis, researchers tend to conduct an initial confirmatory factor analysis. Regarding the measurement model, only one dimension with error terms is measured by every observed variable. Moreover, the dimensions do not correlate with latent dimensions or even with each other.

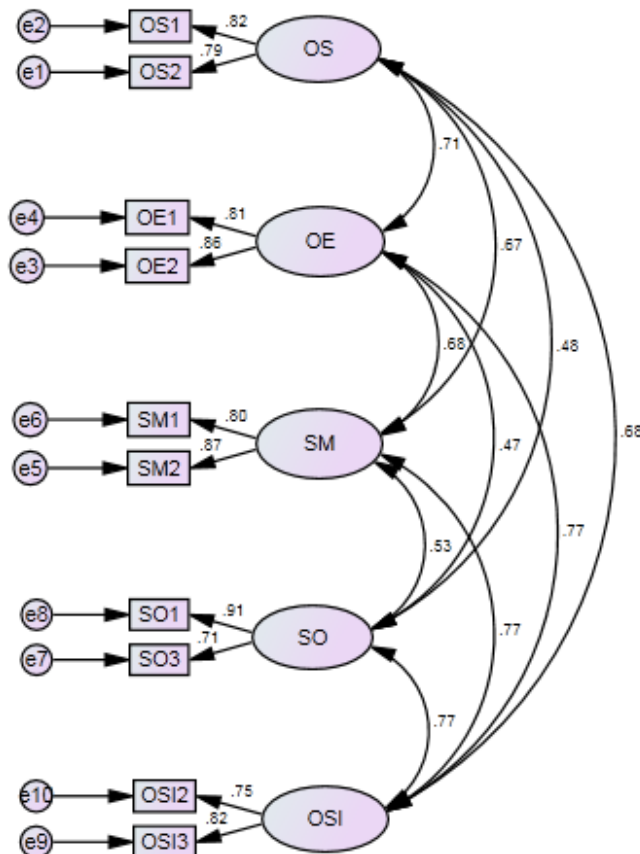

Figure 6-1 Measurement model

### 6.3.4 Indicators of Assessing Goodness-of-fit

It is important to evaluate the level of which a model suits the data of the underlying study. A good fitting model has to be consistent with the data. There are two different indices used in to measure the adequacy of fit for this study. These included complete appropriate catalogs or relative appropriate catalogs (Kline, 2011).

#### 6.3.4.1 Absolute Indices

To measure the minimum discrepancy between covariance matrix of proposed and data of study,  $\chi^2/df$  (CMIN/DF) test is conducted (Holmes- Smith, 2011). The acceptable level of  $\chi^2/df$  is ranging from 1 to 5 (Arbuckle, 2003).

## Chapter Six. Data Analysis II

The Root Mean Square Error of Approximation (RMSEA) was also defined as a measure or amount used to evaluate the fitted model with respect to acceptable sensitivity to model misspecification (Byrne, 2010). The smaller RMSEA is better. As a result, RMSEA was reasonable approximate fit if it lies between .05 and .08 " (Kline, 2011). If the p-value resulting from RMSEA has values greater than 0.05, then it becomes a better gauge to be used in the assessment of hypothesizes. According to Bagozzi and Yi (2012) supported the suggestion given by Steiger (2007) a value of 0.07 or less was an appropriate range of calculating RMSEA. Also, PCLOSE was a one-sided test/analysis of the null hypothesis is that the Root Mean Square Error of Approximation (RMSEA) equals to .05, but it can be resolved that the model' fit is close (i.e. RMSEA is  $< 0.05$ ) if the PCLOSE is  $> 0.5$  (i.e. it is not statistically substantial) (Kenny, 2014).

The RMR was used to calculate the regular variance that occurs between the model's variance-covariance and the matrix's variance-covariance (Byrne, 2010). The RMR was influenced by characteristics of the representation of the entire elements, the number of indicators per latent variable, the scale used for observed variables, the number of dormant variables, and gauge loadings as defined by (Hu & Bentler, 1998). As a result, it is recommended to employ Standardized RMR (SRMR) as a substitute of RMR (Kline, 2011). Hu and Bentler (1998) suggested another similar category of value in SRMR of not more than 0.08.

Jöreskog and Sörbom (1984) advised a vital model to measure the divergence that is denoted as the Goodness-of-Fit Index (GFI). Shevlin and Miles (1998) supported this argument by stating that the GFI's cut-off value ought to be more or equivalent to approximately 0.95 in the event that it ranges from low to intermediate factor loadings irrespective of the size of the sample. The Accustomed Goodness-of-Fit Index (AGFI) is comparable to the Goodness-of-Fit Index; however, according to Holmes-Smith (2011), the Accustomed Goodness-of-Fit Index (AGFI) takes into account the amount of flexibility in this quantified model. In fact, Hooper et al., (2008) explained that there is no agreement to recommend a specific cut-off for AGFI. Several types of research acclaim a value of 0.90. In addition, Chau (1997) continued to elaborate the effectiveness of 0.80 as an appropriate level for AGFI. Various researchers like Hair et al. (2010) and Bagozzi and Yi (2012) agreed that there appear to be many different values for GFI and AGFI. Hooper et. al. (2008) stated that the acknowledged rate of GFI and the Accustomed GFI is more than or equivalent to .90.

### **6.3.4.2 Incremental Fit Indices**

The value of incremental indices lies between 0.0 and 1.0, where zero indicating that that fitted model is poor, whilst 1.0 meaning that the fitted model is perfect as described by Holmes-Smith (2011).

According to Bentler and Bonett (1980), the NFI is a sign of incremental acceptable indicators. Hu and Bentler (1998) stated that Tucker-Lewis Index (TLI) (1973) or Relative Noncentrality Index (RNI) was thought to be similar to the Normed Fit Index (NFI). In their research, Hu and Bentler (1998) noted a critical problem with the use of TLI, where NFI is stated to be the better model between the two and hence giving better results. However, the disadvantage of this take as given by (Tabachnick & Fidell, 2007) is that it has unreliable gauges. Hu & Bentler (1998) pointed out a precautionary measure by using the CFI. Hair et. al. (2010) stated that the CFI is a good indicator which is highly insensitive to model complexity. The cut-off of fit indices considered in this study was  $>.950$ .

### **6.3.5 Validity and Reliability**

The item validity and reliability are needed to be assessed to know the ability of the items in measuring the latent constructs (Cohen, 1988). This approach enabled the researcher to evaluate the quality of data collected (Pallant, 2007).

#### **6.3.5.1 Validity**

Zikmund et al (2009) stated that, “The accuracy of a measure or the extent to which a score truthfully represents a concept.” The validity of each item was measured by a standardized factor loading in the corresponding construct.

A better structure model as attained through frequent examination of rationality to results for informed conclusions. Analysis of the measuring model delivers gauges for evaluating the two main types validity and the structuring model that indicates homological rationality (Schumacker & Lomax, 2004).

In the following section, the main forms of validity that are used in the study are laid out. These forms include construct validity, discriminant validity, and convergent validity. They are described in detail below.



### **Construct Validity**

A wide-ranging measure of validity is called *construct validity*. According to Wang (2003), this can be divided into three categories, namely convergent validity, unidimensionality and discriminant validity. According to Bagozzi and Yi (2012), construct validity can be described as ‘the degree to which a construct and its indicators measure what they are supposed to measure’ (p. 18). Construct validity can be evaluated by the goodness of fit; the model has construct validity if it achieves good fit (Holmes-Smith, 2011).

The relationships between the constructs and the observed variables are evaluated by this type of validity (Schumacker & Lomax, 2004). As far as convergent validity is concerned, ‘the same construct having multiple measures operate in a similar way or hang together’ (Neuman, 2006).

### **Convergent and Discriminant Validity of Constructs**

Schumacker and Lomax, (2004) defined convergent validity as the association existing between experimental variables and hypotheses. Whereas (Neuman, 2006) said it is a repetitive study of similar concepts in an identical manner. Discriminant validity is considered a key measure to test the constructs because since it confirms whether the hypothesized structural paths are real or whether they are a result of statistical discrepancies’ (Farrell, 2010).

Average variance extracted (AVE) and composite reliability (CR) are considered to evaluate the convergent validity of the construct. All three conditions become true ( $AVE > 0.5$ ;  $CR > 0.7$ ;  $CR > AVE$ ); hence, the convergent validity of the measurement model is observed.

Values of AVE, maximum shared variance (MSV) and Shared Average Variance (ASV) were compared to assess the discriminant validity of the constructs. Both the necessary conditions were true ( $ASV < AVE$ ;  $MSV < AVE$ ), and the value of the correlation between constructs was found to be less than the square root of the AVE. Moreover, discriminant validity of the constructs was also found. The correlation matrix with the square root of the AVE on the main diagonal is illustrated in Table 6.7.

**Table 6-6** Convergent and discriminant validity

	CR	AVE	MSV	ASV	OS	SO	OSI	SM	OE
OS	0.788	0.650	0.501	0.408	<b>0.806</b>				
SO	0.802	0.673	0.588	0.328	0.476	<b>0.820</b>			
OSI	0.764	0.619	0.599	0.561	0.677	0.767	<b>0.787</b>		
SM	0.820	0.696	0.599	0.445	0.668	0.526	0.774	<b>0.834</b>	
OE	0.818	0.692	0.598	0.445	0.708	0.471	0.773	0.678	<b>0.832</b>

*Necessary conditions:* CR > 0.7; AVE > 0.5; CR > AVE; MSV < AVE; ASV < AVE

*Note 1:* The diagonal represents the square root of average variance extracted (AVE) of each construct

*Note 2:* CR - Composite Reliability;

AVE - Average Variance Extracted;

MSV - Maximum Shared Variance;

ASV - Shared Average Variance.

### 6.3.5.2 Reliability

Reliability was considered as dependability or consistency of hidden constructs (Neuman, 2006). The indicators to measure reliability used in this study were Squared Multiple Correlation, Construct reliability (composite reliability), and Cronbach's alpha.

#### Squared Multiple Correlation

The amount of variance explained by the independent observed variables is shown by the squared multiple correlation (SMC) coefficients' 'item reliability' (Schumacker & Lomax, 2004). Researchers have also incorporated the squared multiple correlations so that the reliability of each item could be evaluated (Bagozzi & Yi, 2012). SMC exceeding 0.50 provided indication of good reliability for the observed variable of interest, and 0.30 was considered as an acceptable level of item reliability (Schumacker & Lomax, 2004).

#### Construct Reliability (Composite Reliability)

Construct reliability was a measurement of the reliability for all the items representing the corresponding construct. The essential objective for using construct reliability was to examine the internal consistency of the constructs (Holmes-Smith, 2011). The rule of thumb of construct reliability is 0.70 (Hair et al., 2010). A value of construct reliability less than 0.70 was acceptable if the CFA reached satisfactory fit (Bagozzi & Yi, 2012).

### **Cronbach's Alpha**

The test's internal consistency is tested by measuring the Cronbach's alpha. A result of 0.70 is the recommended level, and for exploratory research, 0.60 is acceptable (Hair et al., 2010). George and Mallery (2012) proposed the following rule of thumb for Cronbach's alpha:  $\alpha > 0.9$  = excellent,  $\alpha > 0.8$  = good,  $\alpha > 0.7$  = acceptable,  $\alpha > 0.6$  = questionable,  $\alpha > 0.5$  = poor, and  $\alpha < 0.5$  = unacceptable.

### **6.3.6 Fit Indices Results**

Chi-square statistics (CMIN/DF) was used to assess the measurement. It can lead to misleading result when the sample size is large or violation of normality assumption (Hair et. al., 2010; Byrne, 2010; Schumacker and Lomax, 2004). The relative chi-square should be accepted if its value is ranging from 3 to 1 (McIver& Carmines, 1981). Also, SMRS, GFI, NFI, RFI, IFI, TLI, RMSEA, and PCLOSE were used to assess the model fit. See table 1-10 below for more details. PCLOSE provided a one-sided analysis of the null hypothesis where the Root Mean Square Error of Approximation (RMSEA) was equal to .05, but it was resolved because the model' fit was close (i.e. RMSEA is  $< 0.05$ ) if the PCLOSE provides is  $> 0.5$  (i.e. it is not statistically substantial).

The results are provided below in table 1-10. The results showed that CMIN/DF was less than three while other indices were above accepted limit. In terms of the rest of resulting indices, the model fit indicators for the first iteration did not meet the acceptable threshold, see Table below. According to Jöreskog and Sörbom (1984), the lack of fitting can be attributed to the high standardized residual covariance's of items. Standardized residual covariance for should be less than two in absolute (Jöreskog & Sörbom (1984). A number of iterations were conducted to eliminate items with high residual covariance in order to improve fit indices of the model. For each iteration, an item with high covariance residuals is dropped from the model, and then the fit indices were examined for each iteration. Items deletion was stopped when the fit indices reached the acceptable threshold. By eliminating those items, the resulting fit indices were improved and reached the acceptable threshold. The improved measurement model after eliminating items with high residual covariance was presented in table 6.8 and figure 6.2.

**Table 6-7** Fit indices of measurement model

Indicator	Acceptable value	Initial model before eliminating items	Improved model after eliminating items
CMIN/DF	Below 3	2.918	<b>1.662</b>
RMR	.10 or below	.094	<b>.050</b>
GFI	Close to .90 to 1	.946	<b>.979</b>
NFI	Close to .95 to 1	.918	<b>.979</b>
TLI	Close to .95 to 1	.923	<b>.985</b>
CFI	Close to .95 to 1	.944	<b>.991</b>
RMSEA	< .05 = very good > .05 to .08 = good > .08 to .10 = mediocre > .10 = bad fit	.070	<b>.041</b>
PCLOSE		.008	<b>.730</b>

\* It has become less popular in recent years and it has even been recommended that this index should not be used (Sharma et al,2005). According to Hooper et al. (2008) the accepted value of GFI and AGFI is  $\geq .90$ .

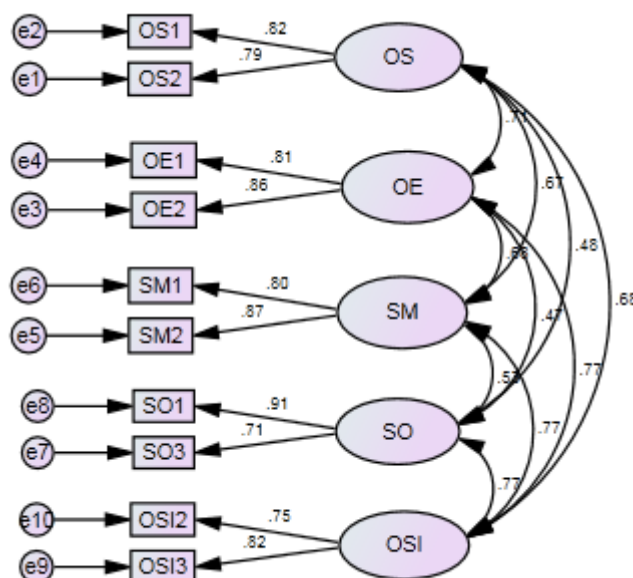

Figure 6-2 Measurement model

## 6.4 The Measurement Model with Second-Order with Motivation

### 6.4.1 CFA for Motivation

Firstly, the measurement model for Motivation (M), which was comprised of 4 sub indicators, was tested. However, as discussed in Chapter 5 concerning reliability and validity, item ‘PS 1 was deleted, as it did not contribute to the scale reliability. Thus, this item was not included in the CFA, as it may not be a reliable measure of motivation (M). This was a counterpart to the CFA process, which focuses much attention on standard error, squared multiple correlations ( $R^2$ ) and standardized loadings for each individual item. The same procedures are applied for all CFA models presented later.

A second order model can be applied after the factors of the lower order are considerably linked with each other and in case there exist a factor of higher order that is theorized to explain the relationship that exists amongst the subordinate order factors. Considering that correlations between AS, CO, IA and PS are above 0.7, it indicated that there are discriminant validity issues in the aim of fixing it, researcher tend to collapse AS, CO, IA, and PS measures into a single construct called Utilitarian Motivation (UM), rather than conduct dimension-by-dimension analysis.

According to Byrne (2010), CFA should be run first in case of a first order so as to present into the research model a higher order structure and at that moment a structure of higher order is

## Chapter Six. Data Analysis II

presented and then the higher order is incorporated into the research model that has been hypothesized.

Accurate statistics were obtained from a good output. The statistics are meant to describe the model's appropriateness. Comparison of the absolute fit of the specified to the Independence models was done through using the Comparative Fit Index (CFI) and the Tucker-Lewis Index (TLI). Large values of the descriptive statistics resulted from the big variance between the models. If the Values are 0.95 or greater, it means that CFI is larger than the TLI (Hu and Bentler, 1998). Any parameter projected may cost CFI pays a consequence. In the case where both TLI and CFI occur together, only one has to be stated. It is better to have the model fit measured through the use of RMSEA which could also be named as "Ramsey." Moreover, MacCallum et al., (1996) emphasized the indication of excellent, good and mediocre fits can be represented by values of 0.01, 0.05, and 0.08.

Sharma et al., (2005) showed that some measures like those of GFI and AGI should not be used because of their interference on the sample size. However, Bentler and Bonett (1980) depicted that there is a better measure that can be used for the fit which describes values which are 0.95 and above as excellent and those less than 0.90 as not good.

When the null hypothesis showed results of a one-sided test or a value equivalent to 0.05, it described p of Close Fit (PCLOSE) and RMSEA respectively but the value can also exceed 0.05 in cases where the RMSEA can be greater than or less than 0.05. In cases where the value is above .05 then p cannot be rejected but is taken to be statistically insignificant and the null hypothesis is not rejected. This is why the word close is used and as a result it is resolved that the model's fit is "close". But when this value is lower than 0.05, the null hypothesis is rejected and said to be not a close fit.

The proposed model showed poor discriminant and convergent validity of the constructs so improvement of the model was made by introducing the second order factor in the measurement model. The specified model was estimated and obtained indicators of goodness of fit which suggested that the model (see figure 6.3 and 6.4 and table 6.9) achieve a good model fit.

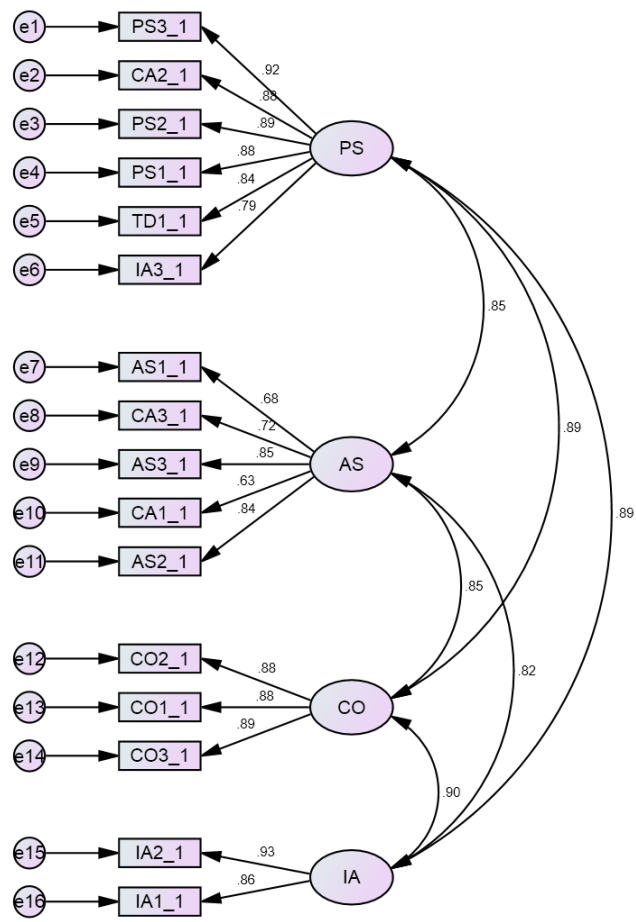

Figure 6-3 first -Order for motivation

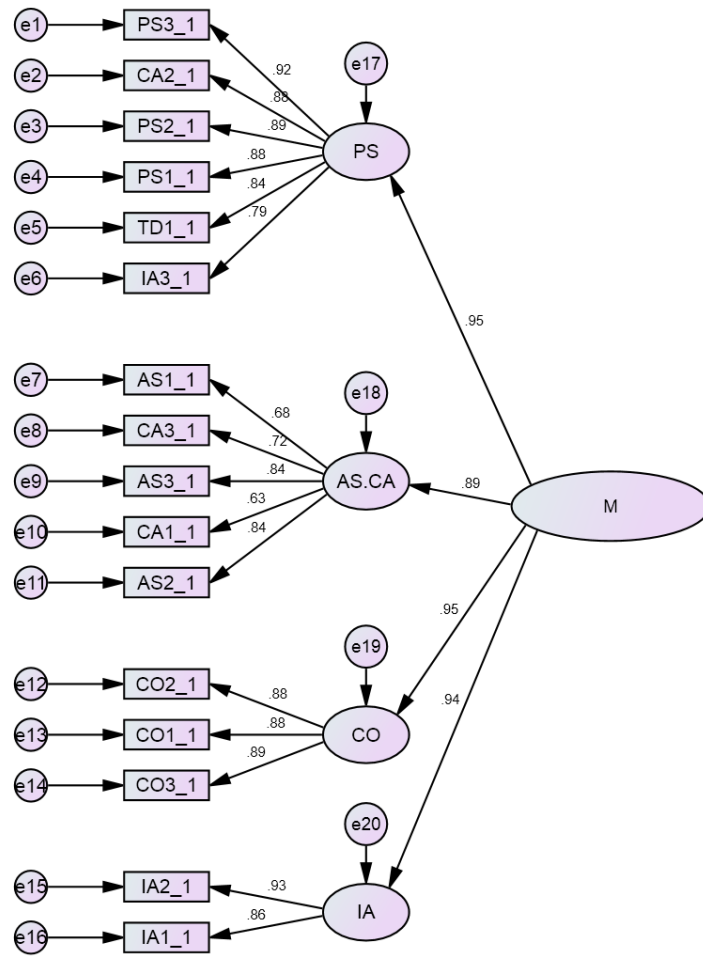

Figure 6-4 Second -Order for motivation



**Table 6-8** Model fit indices

Indicator	Acceptable value	First –order CFA for motivation	Second order CFA for motivation
CMIN/DF	Below 3	2.785	<b>2.753</b>
RMR	.10 or below	.047	<b>.047</b>
GFI*	Close to .90 to 1	.918	<b>.917</b>
NFI	Close to .95 to 1	.954	<b>.954</b>
TLI	Close to .95 to 1	.963	<b>.964</b>
CFI	Close to .95 to 1	.970	<b>.970</b>
RMSEA	< .05 = very good > .05 to .08 = good > .08 to .10 = mediocre > .10 = bad fit	.067	<b>.067</b>
PCLOSE		.001	<b>.002</b>

After confirming the goodness of model fit, two measurement models (discussed previously) are used to create a new measurement model which consisted of constructs: Online shopping (OS), Online shopping experience (OE), Social Media (SM), Online shopping intention (OSI), Shopping orientation and Motivation (M) (see figure 6.5). Thus, specified model showed a good model fit, which indicates fit indices (see table 6.10).

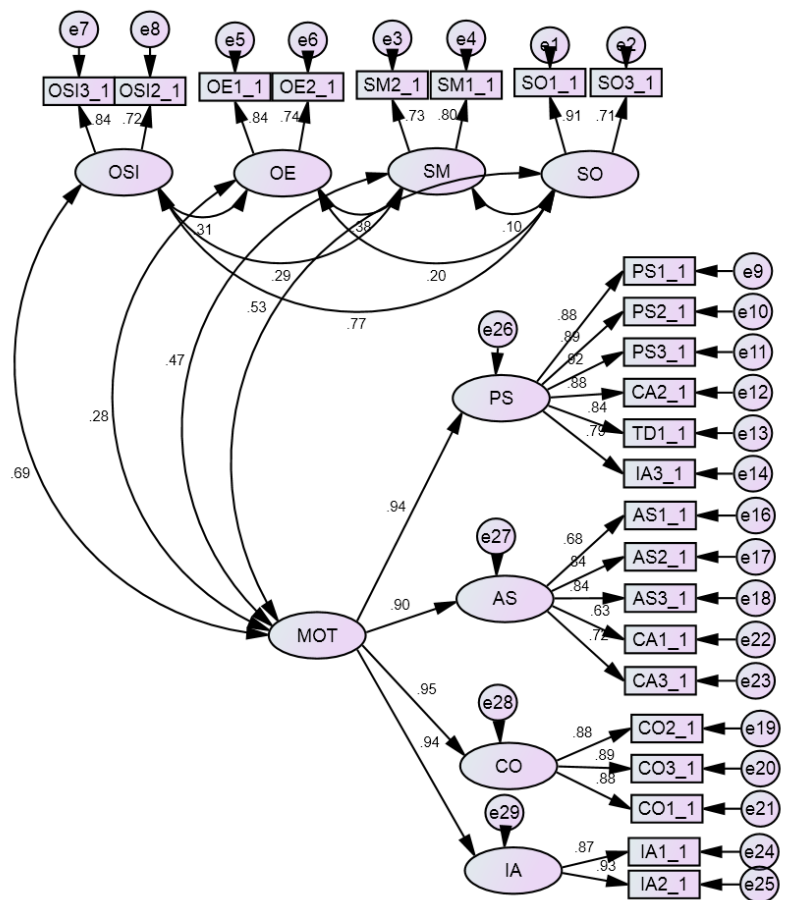

Figure 6-5 Measurement model with second-order with motivation

**Table 6-9 Model fit indices**

Indicator	Acceptable value	Measurement model with second-order with motivation
CMIN/DF	Below 3	<b>2.174</b>
RMR	.10 or below	<b>.071</b>
GFI*	Close to .90 to 1	<b>.898</b>
NFI	Close to .95 to 1	<b>.930</b>
TLI	Close to .95 to 1	<b>.955</b>
CFI	Close to .95 to 1	<b>.961</b>
RMSEA	< .05 = very good > .05 to .08 = good > .08 to .10 = mediocre > .10 = bad fit	<b>.055</b>
PCLOSE		<b>.112</b>

**6.4.2 Convergent and Discriminant Validity**

Convergent validity of the construct is evaluated on the basis of Composite Reliability (CR) and Average Variance Extracted (AVE). All three conditions are met (CR > 0.7; AVE > 0.5; CR > AVE). This indicates that there is a convergent validity of the measurement model. In order to assess the discriminant validity of the constructs, values of Average Variance Extracted (AVE), Maximum Shared Variance (MSV), and Shared Average Variance (ASV) were compared. Both the necessary conditions are met (MSV < AVE; ASV < AVE) and the square root of the value Average Variance Extracted was greater than the value of the correlation between constructs. It was concluded that there is discriminant validity of the constructs as well. Table 6.11 demonstrates the correlation matrix with the square root of Average Variance Extracted on the main diagonal.

**Table 6-10** Convergent and discriminant validity

	CR	AVE	MSV	MaxR(H)	SO	SM	OE	OSI	MOT
SO	0.801	0.672	0.588	0.859	<b>0.820</b>				
SM	0.740	0.587	0.223	0.900	0.103	<b>0.766</b>			
OE	0.768	0.624	0.144	0.926	0.195	0.380	<b>0.790</b>		
OSI	0.758	0.612	0.588	0.941	0.767	0.288	0.312	<b>0.782</b>	
MOT	0.964	0.870	0.477	0.978	0.532	0.472	0.283	0.691	<b>0.932</b>

*Necessary conditions:* CR > 0.7; AVE > 0.5; CR > AVE; MSV < AVE; ASV < AVE

*Note 1:* The diagonal represents the square root of average variance extracted (AVE) of each construct

*Note 2:* CR - Composite Reliability;

AVE - Average Variance Extracted;

MSV - Maximum Shared Variance;

ASV - Shared Average Variance.

## 6.5 Structural Model

According to the structural model, the hypothetical relationships that exist between or among the constructs (Bollen, 1989; Byrne, 2010) as well as identifying whether the values of other constructs that are in the model are directly or indirectly affected by the construct(s) (Byrne, 2010). This section will explain the test of the theoretical conceptual model that recommended the links among SO, SM, and M in the success of OSI. The relevant supporting discussions and concepts of the measurement variables that are linked with the constructs were discussed in the previous chapters.

### 6.5.1 Test The Model and The Hypotheses

After examining the validity and reliability in the identified measurement model, the hypothesis of the study were tested using a regression analysis. SEM was used to estimate the regression model for six variables that include SO, M, OE, OSI, SM, and OS. The proposed model, given in Figure 6.6, was designed to achieve the objective which is to investigate and examine the function of OE in OSI's success. In addition, we examine the attainment of OSI through considering factors like SO, SM, or M. Thus, IT infrastructure was considered as a

## Chapter Six. Data Analysis II

foundation of the success of e-learning systems. The findings of the regression of path examination using SEM to test the study hypothesis were presented in Figure 6.6.

Statistics that were used should be within a stipulated limit i.e. CMIN/df ratio=2.171; Standardized RMR = .045 and the GFI = .951; CFI = .898 and NFI=.930; IFI=.961; TLI=.955 and RMSEA = .071 and a PCLOSE = .112. Thus, the model achieved a good fit.

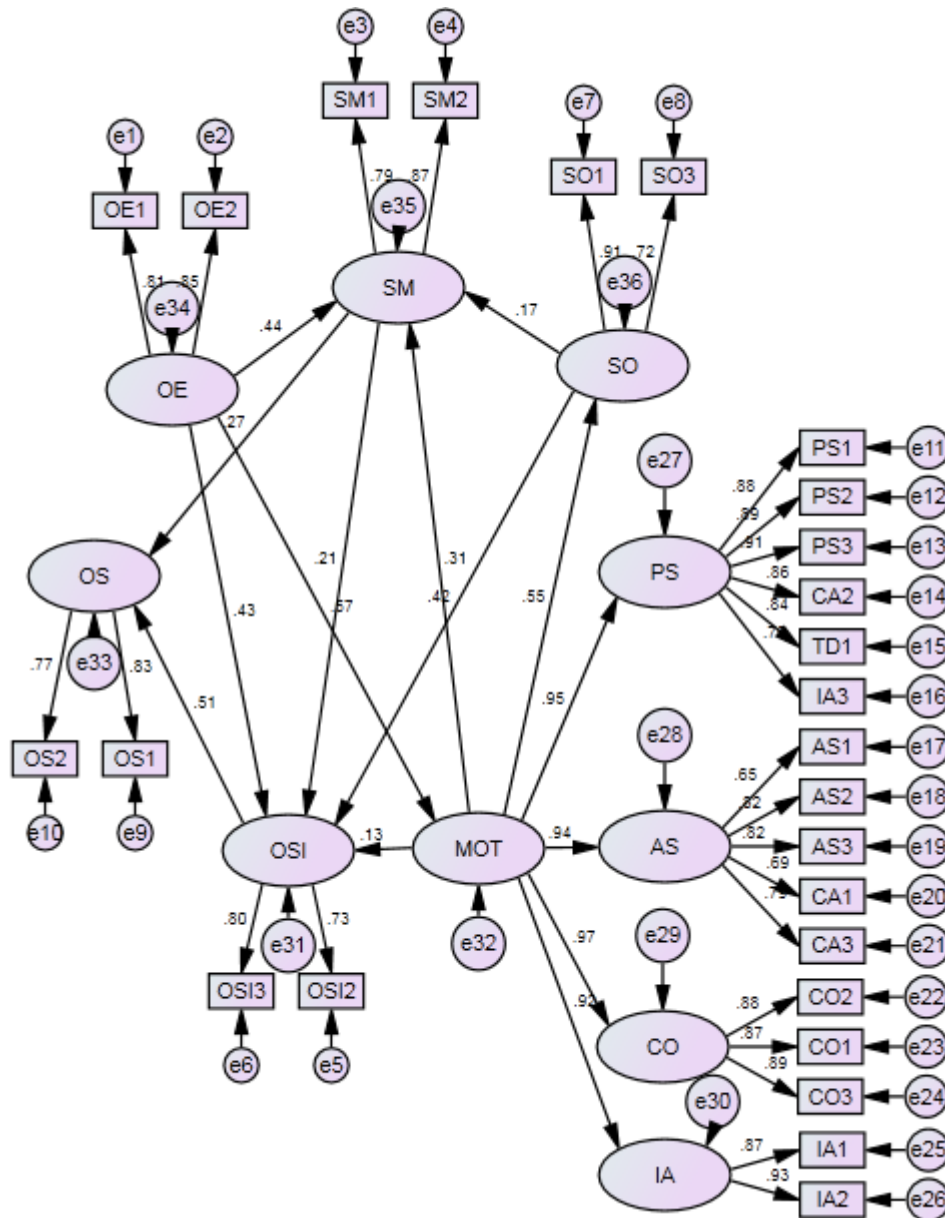

Figure 6-6 Paths diagram of hypothesized model standardized estimates

### 6.5.2 Hypotheses Testing Results of Proposed Model

The findings on Online Shopping Acceptance Model (OSAM) demonstrated that there are causal relationships between Shopping orientation (SO), online shopping intention (OSI), social media (SM), and online shopping intention (OSI), motivation (M) and online shopping intention (OSI), Social media and online shopping and Shopping motivation (M) and social media (SM).

**H1:** Shopping orientation (SO) is positively associated with online shopping intention (OSI).

**H2:** Motivation (M) is positively associated with online shopping intention (OSI).

**H3:** Online Shopping intention (OSI) is positively associated online shopping (OS).

**H13:** Social media is positively associated with through online shopping intention (OSI).

Table 6.12 showed the outcomes of the construct using the different tracks in the event of testing for hypothesis representation given in Figure 6.6 for entire data. SM affects the OSI, where the regression coefficient that describe how the exogenous construct is influenced by the endogenous constructs, and their coefficients are called path coefficients or regression weights was  $\beta = 0.177$  with critical ratio  $t = 2.779$  at highly significant level 0.001. The OSI was significantly impacted through service delivery quality of SO where the regression coefficient was  $\beta = .295$  with critical ratio  $t = 6.858$  at very highly significant level 0.001. Regression tests illustrated that influencing active shopping motivation leads to the use of social media. Namely, OSI was significantly impacted by motivation (M), its regression coefficient is  $\beta = 0.175$ , the t-value being 2.348 with the highest significance of 0.001.

Lastly, OSI showed a strong positive significant influence on OS, while the critical and regression value are 5.147 and .505 respectively. This results in the highest level of significance were 0.001.

**Table 6-11** Results of regression estimates for H1, H2, H3 and H9

Dependent		independent	Regression Weights	S.E.	C.R.	p-value	Standardized Regression Weights	Decision
SO	<---	OSI	.295	.043	6.858	***	0.416	Accept H1
OSI	<---	SM	.177	.064	2.779	***	0.203	Accept H13
OSI	<---	M	.175	.074	2.348	***	0.139	Accept H2
OS	<---	OSI	.505	.098	5.142	***	0.513	Accept H3
Notes: *** p-value < 0.01; ** p-value < 0.05; * p-value < 0.10								

**H4:** Online shopping experience (OE) is positively related to online shopping intention (OSI). After analyzing the findings given in table 6.13, the influence of online shopping experience on the online shopping intention was statistically very highly significant ( $\beta = .423$ ; p-value <.001). Hence, H4 was supported.

**Table 6-12** Result of regression estimate H4

Dependent		Independent	Estimate	S.E.	C.R.	P
OSI	<---	OE	.423	.065	6.459	***
Notes: *** p-value < 0.01; ** p-value < 0.05; * p-value < 0.10						

**H18:** Social media (SM) is positively associated with online shopping (OS) through online shopping intention (OSI).

The mediation concept/indirect effect suggested an underlying theory where a dependent variable was caused by an independent variable through its influence on the mediating variable (MacKinnon, 2008). To examine the indirect effect caused on OSI by M through SM

## Chapter Six. Data Analysis II

(mediation), a bootstrap procedure is provided in AMOS to estimate this indirect effect (Byrne, 2010).

The results showed that direct impact of SM on OS was not significant ( $\beta = .231$  p-value > .10). See table 6.14 for more details. Additionally, the effect of SM on OS through SM was significant ( $\beta = .090$  p-value < .05) indicating SM was the strong mediator variable, which contributed the positive relationship between SM and OS. Hence, H8 was accepted.

**Table 6-13** Result of regression estimate for H9

	Dependent		Independent	Estimate	S.E.	C.R.	P
Direct effect	OS	<---	SM	.231	.170	1.358	.125
Indirect effect (through OSI)	OS	<---	SM	.090	.067	1.343	.016**
Total effect	OS	<---	SM	.426	.105	4.057	.072*

Notes: \*\*\* p-value < 0.01; \*\* p-value < 0.05; \* p-value < 0.10

**H19:** Shopping motivation (M) is positively associated with online shopping intention (OSI) through social media (SM).

The bootstrap procedure was used to test the mediation of SM on the effect of M on OSI. The result showed that direct impact of M on OSI was positively highly important ( $\beta = .175$  p-value < .0001), see Table 6.15. Regarding the effect through SM, the effect was significant ( $\beta = .079$  p-value < .05) indicating SM was the strong mediator variable which contributed the positive relationship between M and OSI. Hence, H13 was accepted.

The result showed that direct impact of M on OSI was positively highly important ( $\beta = .392$  p-value < .0001), see Table 6.15. Regarding the total effect, the effect was significant ( $\beta = .547$  p-value < 0.01) indicating SM was the mediator variable which contributed the positive relationship between OSI and M. Hence, H19 was accepted.



**Table 6-14** Results of regression estimates for H10

	Dependent		Independent	Estimate	S.E.	C.R.	P
Direct effect	OSI	<---	M	.175	.074	2.348	***
Indirect effect (through SM)	OSI	<---	M	.079	.040	1.975	.013**
Total effect	OSI	<---	M	.426	.105	4.057	.005**
Notes: *** p-value < 0.01; ** p-value < 0.05; * p-value < 0.10							

### 6.5.3 Testing the Association of Personal Information on The Model

The significance of this section was to evaluate the causal effect without involving moderation. To enhance or weaken the causal effect, the moderation was adopted to assess the relationships between the model constructs using SEM. For the moderating effects to be investigated, the entire sample was first subdivided into low and high groups as per the individual’s median including age, education, gender and income.

If the Z-score difference between the two pairs of models-- low and high is substantial, it can then be stated that the association influences across the two groups are significant (Baron & Kenny 1986; Byrne, 2010).

#### 6.5.3.1 Age Association

**H14:** Age is negatively associated with online shopping intention (OSI) through social media (SM).

From Table 6.16, for the relationship between SM and OSI, only high age group was inclined to be affected by SM when their attitude towards OSI ( $\beta_{\text{low age}} = .112$ ,  $p\text{-value} > .10$ ;  $\beta_{\text{high age}} = .252$ ,  $p\text{-value} < .01$ ) was being formed, indicating that the high age showed more influence. However, the results of z-score variation comparisons amongst various pairs of different models indicated that there was a insignificant variation between low age group and high age group model ( $z=1.116$ ). Hence, age was not the association variable, and hence H14 was rejected.

## Chapter Six. Data Analysis II

**H8:** Age is negatively associated with online shopping intention (OSI) through shopping orientation (SO).

For the relationship between SO and OSI, both age groups were influenced by shopping orientation when forming their attitude toward online shopping intention ( $\beta_{\text{low age}} = .309$ ,  $p\text{-value} < .001$ ;  $\beta_{\text{high age}} = 0.247$ ,  $p\text{-value} < .001$ ). Also, the low age showed slightly lower influence than high age. However, there was no major variation between the model of low age group and the model of high age group ( $Z = -0.338$ ). Hence, age is not the association variable (H8 was rejected).

**H9:** Age is negatively associated with online shopping intention (OSI) through shopping motivation (M).

Shopping motivation had a very highly significant, positive, influence on the intent of shopping online, for only low age groups ( $\beta_{\text{low age}} = 0.231$ ,  $p\text{-value} < .01$ ;  $\beta_{\text{high age}} = 0.117$ ,  $p\text{-value} > .10$ ). The result of z-score for the comparison amongst pairs of various given models indicated that there was an insignificant variation amid the model of low age group and the model of high age group ( $z = -0.774$ ). Hence, age was not the association variable (H9 is rejected).

**Table 6-15** Result of age association

Dependent		Independent	<30 years		≥30 years		z-score	Hypothesis
			Estimate	P	Estimate	P		
OSI	<-- -	SM	0.112	0.214	0.252	0.004	1.116	H7a
OSI	<-- -	SO	0.309	0.000	0.247	0.000	-0.338	H5a
OSI	<-- -	M	0.231	0.010	0.117	0.319	-0.774	H5e

Notes: \*\*\* p-value < 0.01; \*\* p-value < 0.05; \* p-value < 0.10

### 6.5.3.2 Gender Association

**H17:** Gender is positively associated with online shopping intention (OSI) through social media (SM).

As shown in table 6.17, SM showed significant positive influence towards the OSI, for only males ( $\beta_{\text{female}} = 0.256$   $p\text{-value} < .01$ ;  $\beta_{\text{male}} = 0.158$   $p\text{-value} < .10$ ). The resulting z-score ( $Z = --$

## Chapter Six. Data Analysis II

0.765) was insignificant indicating that both males and females tended to have the same influence and hence H17 was rejected.

**H8:** Gender is positively associated with online shopping intention (OSI) through shopping orientation (SO).

The SO showed very highly significant positive influence towards the OSI for both males and females ( $\beta_{\text{female}} = .349$  p-value < .001;  $\beta_{\text{male}} = .291$  p-value < .001). The resulting z-score ( $Z = -.614$ ) was insignificant indicating that both males and females tended to have the same influence. The gender was not the association variable and hence H8 was rejected.

**H12:** Gender is positively associated with online shopping intention (OSI) through shopping motivation (M).

The shopping motivation (M) showed significant positive influence towards the OSI, only for females ( $\beta_{\text{female}} = -0.013$  p-value > .10;  $\beta_{\text{male}} = 0.220$  p-value < .05). The resulting z-score ( $Z = 1.488$ ) was insignificant indicating that both males and females tended to have the same influence. Thus, H12 was rejected.

**Table 6-16** Result of gender association

Dependent		Independent	Male		Female		z-score	hypothesis
			Estimate	P	Estimate	P		
OSI	<-- -	SM	0.256	0.009	0.158	0.056	-0.765	H17
OSI	<-- -	SO	0.349	0.000	0.291	0.000	-0.614	H8
OSI	<-- -	M	-0.013	0.916	0.220	0.021	1.488	H12

Notes: \*\*\* p-value < 0.01; \*\* p-value < 0.05; \* p-value < 0.10

### 6.5.3.3 Education Association

**H15:** Education is positively associated with online shopping intention (OSI) through social media (SM).

From table 6.18, for the relationship between SM and OSI, only low education group tended to be affected positively by SM during the formation of their attitude towards OSI ( $\beta_{\text{low education}} = 0.365$ , p-value < .001;  $\beta_{\text{high education}} = 0.042$  p-value > .10), indicating the low education showed

## Chapter Six. Data Analysis II

more influence. The result of z-score on the difference amongst various pairs of given models indicated that there was a substantial variation between the group of low education model and the model of high education group ( $z=-2.264^{**}$ ). Hence, education was the association variable. However, the negative z-score for the group of low education model and the model of high education group means that education is negatively associated with online shopping intention (OSI) through social media (SM). Hence, H15 was supported.

**H6:** Education is positively associated with online shopping intention (OSI) through shopping orientation (SO).

For the relationship between SO and OSI, both education groups were positively influenced by shopping orientation when forming their attitude toward online shopping intention ( $\beta_{\text{low education}} = 0.365$  p-value < .001;  $\beta_{\text{high education}} = 0.263$  p-value < .001), indicating the high education showed slightly more influence than low education. There was no significant difference between the model of low education group and the categorized as high ( $z=-1.127$ ). Hence, education was not the association variable and H6 was rejected.

**H10:** Education is positively associated with online shopping intention (OSI) through shopping motivation (M).

Low education groups were negatively influence, while high education groups were positively influenced by shopping motivation when forming their attitude toward OSI ( $\beta_{\text{low education}} = -0.164$ , p-value < .10;  $\beta_{\text{high education}} = 0.356$ , p-value < .001), where both education groups showed considerably different effect. In addition, a major discrepancy existed between the model of low education group and model of high education group ( $z=3.626^{***}$ ). Hence, education was the association variable and H10 was supported.

**Table 6-17** Result of education association

Dependent		Independent	Low education		High education		z-score	Hypothesis
			Estimate	P	Estimate	P		
OSI	<-- -	SM	0.341	0.000	0.042	0.674	-2.264**	H15
OSI	<-- -	SO	0.365	0.000	0.263	0.000	-1.127	H6
OSI	<-- -	M	-0.164	0.100	0.356	0.000	-3.63***	H10

Notes: \*\*\* p-value < 0.01; \*\* p-value < 0.05; \* p-value < 0.10

### **6.5.3.4 Income Association**

**H16:** Income is positively associated with online shopping intention (OSI) through social media (SM).

Based on table 6.19, for the relationship between SM and OSI, low income seemed to be influenced positively by SM when their attitude was being formed toward OSI ( $\beta_{\text{low income}} = .183$ ,  $p\text{-value} < .01$ ;  $\beta_{\text{high income}} = .247$ ,  $p\text{-value} > .10$ ). The resulting z-score on the assessment and comparison between different models showed that no much divergence between the two groups of income identified that is, low and high ( $z=0.357$ ). Hence, income was not the association variable and H16 was rejected.

**H7:** Income is positively associated with online shopping intention (OSI) through shopping orientation (SO).

For the relationship between OSI and SO, low and high-income groups were influenced by SO when forming their attitude toward OSI ( $\beta_{\text{low income}} = 0.270$   $p\text{-value} < .001$ ;  $\beta_{\text{high income}} = 0.321$ ,  $p\text{-value} < .001$ ) the group of high income portrays a better effect. However, the results of z-score showed no significant variance between the two models of low and high-income groups ( $z=0.568$ ). Hence, education was not the moderation variable. Thus, H7 was rejected.

**H11:** Income is positively associated with online shopping intention (OSI) through shopping motivation (M).

Groups that had low income were influenced by shopping motivation (M) when forming their attitude toward online shopping intention ( $\beta_{\text{low income}} = .204$ ,  $p\text{-value} < .05$ ;  $\beta_{\text{high income}} = .017$ ,  $p\text{-value} > .10$ ), where low-income group seemed to show slightly higher effect than high income-group. Based on the resulting z-score, there was the insignificant difference between the two model of low and high-income groups ( $z=-1.165$ ). Hence, education was not the association variable and H11 was rejected.

**Table 6-18** Result of income association

Dependent		Independent	Low income		High income		z-score	Hypothesis
			Estimate	P	Estimate	P		
OSI	<-- -	SM	0.183	0.006	0.247	0.133	0.357	H16
OSI	<-- -	SO	0.270	0.000	0.321	0.000	0.568	H7
OSI	<-- -	M	0.204	0.014	0.017	0.903	-1.165	H11

Notes: \*\*\* p-value < 0.01; \*\* p-value < 0.05; \* p-value < 0.10

## 6.6 Summary

This chapter detailed the methods employed to test the hypothesis and the measurement model. The data perceptions were presented in the first section of this chapter while Normality was explained on the second section of the chapter. This section focused on the testing of the measurements model and testing and analysing the validity and reliability of the constructs and items. The last section paid attention to testing the study’s hypothesis and the study model by use of six constructs. The results of hypothesis test of the study model indicated that:

- 1- Shopping orientation (SO) was strongly supported since it had a positive relationship with the online shopping intention (OSI).
- 2- Social media (SM) was supported since it was positively related to the online shopping intention (OSI).
- 3- Motivation (M) was strongly supported since it was positively related to the online shopping intention (OSI).
- 4- Online Shopping (OS) being positively associated online shopping intention (OSI)” was strongly supported.
- 5- Online shopping experience (OE) being positively related to online shopping intention (OSI) was supported.
- 6- Social media having a positive relationship with the online shopping (OS) through online shopping intention (OSI) was strongly supported.
- 7- Shopping motivation (M) was supported to have a positive relationship with the online shopping intention (OSI) through social media (SM).

## Chapter Six. Data Analysis II

The following chapter discusses and addresses the details the questions of this research study. The chapter drew upon the research findings and are followed by the conclusions of the overall data analysis. This includes the implications of these findings and suggestions for future research.

## Chapter Seven. DISCUSSIONS

### 7.1 Chapter Overviews

This chapter continues the discussion of the findings from Chapters five and six with a focus on answering the research questions presented earlier in Chapter 1. This chapter summarises the research findings by analysing how the results of the hypothesis testing have contributed towards addressing the research questions.

### 7.2 Introduction

This research aims to **explain** acceptance of online shopping in Saudi Arabia using **OSAM** and the additional variable of **social media**.

The research is aimed at achieving the following two objectives:

- To understand online shopping acceptance through **OSAM** in Saudi Arabia.
- To understand the role of **social media** in online shopping acceptance in Saudi Arabia.

The discussion is based on the results of statistics emerging from the data collected. The statistical outcomes discussed in this chapter are based on the results of hypothesis testing, research objectives, research questions realisations, and finally the unique inferences resulting from this study.

This chapter illuminates the limitations of the research and how they could be best addressed in future research. The research further highlight trends in online shopping in Saudi Arabia. The statistics discussed in this chapter can assist businesses in making decisions on what target market they have online and what to sell to them based on what factors.



### **7.3 Discussion of Research Questions**

A structural equation model was the major tool that was used to determine if their existed structural relationships on the proposed OSAM revised model. As presented in the preceding chapter, out of the fifteen hypotheses proposed only nine of them in this study were supported. Moreover, the hypotheses generated statistically significant t-values and standardized coefficient scores (see Chapter 7, Section 7.3.1). The subsequent sections offer detailed discussions of the findings addressed by the following research questions:

- What are the factors affecting online shopping acceptance?
- What role does social media play in online shopping acceptance in Saudi Arabia?

To address the research questions, this section is devoted to the assessment of the OSAM (see RQ1) and the examination of each hypothesis path, which includes M, OS, SO, and OSI. Hypotheses H1to H12 were confirmed (see table 7.1) which means that shopping orientation (SO), some consumer demographic characteristics (CD), and shopping motivation (M) were found to influence online shopping acceptance in Saudi Arabia. Social media (SM) and in certain cases clarifying specific added a new factor which social media on OSAM (see RQ2). Subsequently, by responding to the research questions, this study was able to explicitly highlight the contributions of this research.

**Table 7-1** Proposed Structural Model and Hypotheses Test Results

H1	Shopping orientation (SO) is positively associated with online shopping intention (OSI)	Supported
H13	social media (SM) is positively associated with online shopping intention (OSI).	Supported
H2	Motivation (M) is positively associated with online shopping intention (OSI)	Supported
H3	Online Shopping intention (OSI) is positively associated online shopping (OS).	Supported
H4	Online shopping experience (OE) is positively related to online shopping intention (OSI).	Supported
H18	Social media (SM) is positively associated with online shopping (OS) through Online shopping intention (OSI).	Supported
H19	Shopping motivation (M) is positively associated with online shopping intention (OSI) through social media (SM).	Supported

### 7.3.1 Online Shopping Orientation

Hypothesis H1 proposed that shopping orientation had a positive relationship with online shopping intention. The shopping orientation factors were identified. Al-Somali et. al. (2009) hypothesised that the general concept of the orientation of shopping was a particular lifestyle which is put into action by a diverse activity range. This hypothesis is applicable to the different shopping decisions.

Al-Somali, et al (2009) and Li, Kuo and Russell (1999) agree on the same definition of online shopping orientation: a certain aspect of a lifestyle that is made possible by a number of activities, interests, and opinions that are in line with shopping decisions and consequently affect the consumer’s intention shop online shopping. Such factors include: the perceived ease of use, perceived usefulness, perceived risk, product involvement, subjective norms, the attitude of the consumer towards online shopping, and the consumer’s intention to use online shopping.

## Chapter Seven. Discussions

Product involvement is a defining factor that relates to online shopping intention. Product involvement is defined as the perception that a consumer has of a good, based on the existing needs, values, and interests. Bo et al. (2014) explained that product involvement for a consumer can either be low or high. Bo et al. (2014) indicated that consumers who have high product involvement tend to be interested in researching further on products and services in order to gain more information. Such consumers are more likely to compare product characteristics and less likely to be concerned with the product's brand. Consumers with a high product involvement were found to remain loyal to a brand for products within the same category. High product involvement consumers have a slow purchase decision making process.

Product involvement does influence the decision making a process on the purchase of a particular product. Yi et al., 2016 has established that high product involvement has a positive effect on users attitudes towards online shopping. The availability of product information and the availability of similar products on different websites influences consumer decisions regarding online shopping (Yi et al., 2016). Therefore consumers with high product involvement are likely to have a positive attitude towards shopping and more likely to develop the personal intention to shop online.

Kwek et al., (2010) highlights subjective norms as the other factor that relates to shopping intention. Subjective norms refer to the social pressure to behave in a certain manner. The definition is in accordance with the theory of reasoned action. Whether an individual approves or disapproves of a specific human behaviour is attributable to the normative beliefs the individual holds. Thus, it can be said that subjective norms are a result of an individual's normative belief that a particular behaviour is acceptable, encouraged, or even promoted by a circle of influence. Additionally, subjective norms are categorised into social influence and societal norm.

Nai-Hua & Ya-Wen, (2015) has found that consumers shopping behaviour was influenced by their believes concerning the online shopping preferences of family, friends, and peers. Further literature has established a correlation between engaging in conversation about online shopping with friends and the consumer's intention to engage in online shopping. Therefore, a consumer's intention to shop online can be increased by positive contributions

## Chapter Seven. Discussions

from the media and the individual's family or social group, and by attempting to control the variables contributing to risk which lead to the de-motivation to conduct online purchases (Nai-Hua & Ya-Wen, 2015).

Al-Somali et. al. (2009) recognise the seven types of shopping orientation that are based on the study of the relationship between online shopping orientation and the shopping orientation more generally. The seven types are: in-home shoppers, economic shoppers, mall shoppers, personalised shoppers, ethical shoppers, convenience shoppers, and enthusiastic shoppers. In-home shoppers are consumers who prefer to shop from home. Economic shoppers are consumers who check multiple locations before making any purchasing decision. However, the outcome of this study showed a positive correlation between shopping orientation with online shopping intention as it revealed a  $p$ -value  $< 0.01$ ,  $SRW = 0.747$  and  $CR = 9.508$ .

### **7.3.2 Online Shopping Experience**

Hypothesis H4 proposed that online shopping intention (OSI) and online shopping experience (OE) are positively correlated. Online shopping experience affects online shopping intention. This hypothesis is supported by the findings of this study. The Online Shopping Acceptance Model proposed by Zhou et al., (2007) further supports this hypothesis. According to Zhou et al., (2007), a consumer's online shopping intention is positively affected by their online shopping experience. Furthermore, other studies have also demonstrated that repurchase intention is positively affected by online experience (Mikalef et al., 2012).

The analysis from Ngai et. al. (2015) proposed the quadrant. The analysis of quadrant helped in charting the importance that is derived from each of the factors and contrast this with the satisfaction rating. It is considered important for the retailers because they want to sustain the high satisfaction levels on elements of the online shopping experience.

However, Ngai et. al (2015) found the factors that are mentioned in the shopping experience are of lower importance in satisfying the online shopping. Bo et al., (2014) investigates the relationship between the three types of risks and previous online shopping

experience and purchase intentions. The first question that the study seeks to address is the influence of previous online shopping experience on the three types of risks. The results indicate that previous online shopping experience reduces the perception of a product, and financial risks related to online shopping.

### **7.3.3 Shopping Motivation**

As there two hypotheses (H2 and H10) related to shopping motivation (M), it was found that online shopping intention (OSI) and shopping motivation (M) are positively correlated; moreover, they are positively connected through social media (SM). A positive effect of shopping motivation on online shopping intention through social media is illustrated by the findings of this study.

The first study to explore the motivations for shopping was Tauber (1972). Tauber (1972) found that consumers are motivated by the various psychological needs. Such motivations can be categorised into personal motivations and social motivations. Personal motivations include diversion, the stimulation of the senses, role playing, physical activity, self-gratification, and learning about some of the recent trends. Social motivations include the attractions of the peer groups, authority, social experiences, bargaining pleasure, and the communication with others (Tauber, 1972).

Al-Maghrabi et. al. (2011) suggested that the motivations for shopping comprise motivations that are deemed as either functional or non-functional. Functional motivations are the perceptible qualities such as variety, convenience, and physical facility, along with the merchandise quality. Non-functional motivations are the social essentials for interacting with different people. Hernández et. al (2011) considered the growth of a class of online shoppers that are a result of the motivations of shopping. However, there are no studies on Saudi Arabia that **explain** the existence of motivations as a factor in online shopping. Hernández et. al (2011) findings implicated empirical evidence that holds that online shoppers shop based on motivations as opposed to physical storefronts. Consumers received more than product value, that is, a memorable online shopping experience where they derived pleasure and joy.

## Chapter Seven. Discussions

With regard to the effect of shopping motivation on online shopping intention, the outcome is consistent with that of Mikalef et. al., (2012). The study from Mikalef et al., (2012) provides a clarification on both utilitarian and hedonic motivation factors to have a positive significant impact on online shopping intention to buy products from websites. However, the authors further clarify that utilitarian is a stronger motivator when compared to hedonic motivations.

Users who spend a lot of time on social media and browsing the internet are more likely to be driven by utilitarian motivators and less likely to be driven by hedonic motivators. These findings validate the notion that online communities have a strong positive value to those who use them (Bateman et. al., 2010). The findings support the utilitarian motivation strategy of considering not just the product but also the platform through which it is advertised (Kourouthanassis et. al., 2008; To et. al., 2007); the results demonstrate that utilitarian motivations are a result of influence by factors such as convenience, cost saving, availability of information, and product selection. These factors are simply classified as determinants of consumer purchase intention.

Additionally, the hedonic factors were reviewed for this present study. It was discovered that the constructs of trend discovery impact online shopping intention. As elaborated, there is a significant positive relationship of trend discovery with product. The relationship is justifiable through continuously updating the products on social media. The process of updating requires little effort when compared to the conventional form of shopping. The online users are thus able to enjoy the latest fashion and product trends. Further, the comments offered by other users through online discussions influence the consumer's realization of trends. Therefore, it is valid to argue that social media attracts users to the latest trends (Bo et al., 2014). Notwithstanding that, some of the users engaging on social media browsing products do so out of adventure.

According to Ozen and Kodaz (2016), hedonic shoppers love to shop. However, their love for shopping does not concern obtaining the product; that does not give them satisfaction. In the case of the hedonic shopper, the most crucial factor is the enjoyment that they derive from the overall shopping process. Consequently, the hedonic shopper is given more

## Chapter Seven. Discussions

attention because they are inclined towards emotions and experiment as opposed to utilitarian shopper.

### **7.3.4 Social Media**

The two hypotheses (**H7 and H10**) related to social media posit that (1) social media (SM) has a positive relationship with online shopping intention (OSI) and (2) social media has a positive relationship with online shopping (OS) through online shopping intention (OSI). The research findings point to a positive effect of social media on online shopping intention and online shopping .

The finding of this study agree with Al-Maghrab et. al. (2012) that social media reveals definite insights about why and how the shoppers engage with the brands of the retails on different channels. The survey indicated that around eighty-four percent of the shoppers make use of such social media channels. This is mainly because online shopping through social media can offers several insights. There are two important foundations. Shopping enjoyment and trust have positive effects on improved purchase intention in social media as confirmed by Lee et. Al., (2007). In addition, the most important finding by Mikalef et. al., (2012) was the strong positive relationship between online shopping intention and online shopping.

### **7.3.5 Consumer Demographic**

According to Zhou et. al., (2007), age, income, education level, and gender are major predictors major predictors of a consumer's likeliness to shop online/engage in online shopping (see table 7.2 for summary result). Another issue regarding online purchasers is that most of them are young, well educated, and have a higher income, as compared to those who never bought a product online.

Typically, online shoppers are young, affluent, and male (Brosdahl & Almousa, 2013), according to the findings of the research studies in which the relationship between online

## Chapter Seven. Discussions

shopping and consumer demographics was analysed. On the contrary, it was stated that these associations were not always conclusive.

For instance, it was shown by Hernández et. al. (2011) that there is no such role played by gender to predict the intentions in online shopping. In addition, it was suggested by Shiau and Luo (2012) that there was a change noticed in the demographic profile of the online shopper over the years. Gender, income, and age appeared as the important indicators along with the orientations of the local shopping, economic, and the home in particular. Demographic information is easier to collect and considered as more freely accessible when compared with th information on a consumer's shopping orientation. A correlational analysis was conducted to distinguish the connection between the two variables of the market segmentation.



**Table 7-2** Summary of testing the moderation

		Dependent	Independent	
Age	H14	OSI	SM	Rejected
	H5	OSI	SO	Rejected
	H9	OSI	M	Rejected
Education	H15	OSI	SM	Supported
	H6	OSI	SO	Rejected
	H10	OSI	M	Supported
Income	H16	OSI	SM	Rejected
	H7	OSI	SO	Rejected
	H11	OSI	M	Rejected
Gender	H17	OSI	SM	Rejected
	H8	OSI	SO	Rejected
	H12	OSI	M	Rejected

### 7.3.5.1 Age

Three hypotheses (H5, H9 and H514) posit that online shopping intention and age are negatively correlated. According to the findings of this study, through shopping orientation, social media and shopping motivation, age can have a positive effect on online shopping intention. We observed this from the outcomes of the z-score difference in the comparison between pairs of given models. The models for the low age group and high age group exhibited a considerable difference.

## Chapter Seven. Discussions

According to the findings of Stafford et al., (2004), a positive relationship was found between consumers' age and their likelihood of buying online products. However, other indicators have been identified that indicated there was no relationship (Li et al., 2007; Rohm & Swaminathan, 2004) or a negative relationship (Joines et al., 2003).

Some researchers found an inverse relationship between age and the acceptance of various technologies in different contexts. Akhter (2003) found that younger people have a higher likelihood of purchasing products and services over the Internet when compared to older people. Shiao & Luo (2012) assert that there is an ever-narrowing gap in the age of online and non-online consumers. Even though the effect of age on consumer's shopping intention does not remain clear.

### ***7.3.5.2 Education***

The three hypothesis (**H6, H10 and H15**) related to education posted that (1) education has a positive relationship with online shopping intention (OSI) through social media (SM), (2) education has a positive relationship with online shopping intention (OI) through shopping orientation (SO), and (3) education has a positive relationship with online shopping intention (OSI) through shopping motivation (M).

Education has a positive relationship with online shopping intention. The findings of this study revealed positive effects for H10 and H15, which was positive on social media and online shopping motivation. Thus, there was a negative effect on shopping orientation (H6) because it was not a significant difference between model of low education group and model of education.

Some findings of this study are similar to that of other studies which indicate that people who buy online are not always more educated than those who do not shop online (Mahmood & Bagchi, 2004; Bellman et. al., 1999; Donthu and Garcia, 1999; Mahmood et. al., 2004). On other hand, other studies found a relationship between education and factors such as time and money consumers spend online (Li et. al., 1999; Liao & Cheung, 2001; Susskind, 2004). In addition, Punj (2011) found that consumers who had obtained higher

## Chapter Seven. Discussions

levels of education reported buying products in excess of their needs as compared to those with lower levels of education.

### ***7.3.5.3 Income***

The three hypothesis related to income (**H7, H11 and H16**) posit that income has a positive relationship with online shopping intention through social media, online, shopping motivation, and shopping orientation. Based on the results of this study, all hypotheses were rejected because there was no significant difference between the model of the low-income group and the high-income group.

However, Schepers and Wetzels (2007) found that income is completely related to the consumer's inclination to shop online. The procedure of sampling used in this study was proposed to replicate the population based on the levels of the income. However, the data on household income for the target sample was not obtainable. A replacement measure was used. According to Hernandez et. al. (2011), people who have higher levels of income are likely to be perceived to have greater enjoyment when shopping online.

### ***7.3.5.4 Gender***

There are three hypotheses related to gender (**H8, H12 and H17**) which posit that gender has a positive relationship with online shopping intention. The findings of this study indicate that there is a negative relationship between gender and online shopping intention though shopping orientation (SO), social media (SM), and motivation (M). There are many studies which demonstrate that there is a relationship between gender and online shopping intention however the results from this study do not agree.

Therefore, it is evident that males and females have different tastes in products and services when making purchases. For instance, males tend to have interest in products such as hardware, software, and electronics. On the contrary, females tend to have interest in products such as food, beverages, and clothing. E-commerce at its initial stages was male oriented because all the products sold were those that interest mostly males (Van Slyke et.

## Chapter Seven. Discussions

al., 2002). Consequently, women were not able to make purchases because they were not able to identify the products that they were interested in.

When evaluating a product, women need more tangible input than men (Citrin et. al., 2003). Thus, the fact that women are not able to touch and try on some of the products sold online may be a reason for fewer female online shoppers. This factor affects female consumers the most and has a negative effect on online purchases of products that required evaluation through tangibility.

Dittmar et al., (2004) references the differences in conventional shopping motivations between men and women as a likely explanation for why women have a lower likelihood of buying online.

### **7.4 Summary**

This discussion of the research questions explicitly clarifies several important issues on consumer in the context of the online shopping in Saudi Arabia. The results demonstrate that consumer demographic is not equally important as others variables in the model. On the other hand, shopping orientation is the most directly influence on online shopping intention.

Online shopping orientation is a process that influences the online shopping intention. Orientation is complex because it includes perceived ease of use, perceived usefulness, perceived risk, product involvement, subjective norms, and attitude of consumers towards online shopping.

Perceived ease of use refers to the perception that the users have regarding the level of difficulty to access the online shopping platform. When the users perceive that online shopping is easy then they are likely to have a positive online shopping intention. Perceived usefulness is another factor that refers to the benefits that that a user is likely to derive from using the online shopping technology. If the consumers perceive benefits that are in line with their expectations during the online shopping process, then they are likely to make a purchase. Perceived risk implies the perception that a consumer is likely to either lose or gain upon deciding to shop online. The risk can be reduced by the online retailers to

## Chapter Seven. Discussions

increase consumer's online shopping intention. Product involvement is the idea that the product is not physically available for testing and thus the consumers have to develop expectations. Consumers with high expectations from a product are referred to have high product involvement. These types of consumers tend to seek for more information and compare products before making a purchase in order to be sure that the product will meet the existing needs which has led them to make a purchase online. Therefore, to ensure that the consumers have online shopping intention in the instance of high product involvement, information should be readily available on the products for sale.

Online shopping is another factor that has a positive relationship with online shopping intention. Online shopping relationship was examined with and without three types of risks. The three types of risks taking the place of mediation are previous online shopping leads to a reduced perception of a product, privacy risks, and financial risks related to online shopping.

Shopping motivation refers to the catalyst for consumers to make a purchase online. It is a factor that has a positive relationship with online shopping intention. As pointed out in the discussion of customer motivation, it can be encouraged through diversity and variability of psychological needs. Motivations can be divided into social motivations and the personal motivations that include diversion, the stimulation of the senses, role playing, physical activity, self-gratification, and learning about some of the recent trends. Additionally, social motivations include the attractions of the peer groups, authority, social experiences, bargaining pleasure, and communication with others.

This study did not only seek to explain the acceptance of online shopping but further to propose answers concerning the use of social media for online shopping. This study has been designed to explain the acceptance of online shopping and the role which social media plays to influence that acceptance. Therefore, social media is a part of the hypothesis that has to be determined against online shopping.

Consumer demographic is the last factor that was taken into consideration in relation to online shopping; the relationship between these two variables was equally positive. The components of consumer demography, which include income, gender, education level, and age, were major predictors of online shopping.

## Chapter Seven. Discussions

The following chapter will illuminate the pertinent results reported in this chapter with a view to presenting the study's contributions to theoretical and practitioners' perspectives. Then, limitations of the study and potential future research opportunities and directions will be presented.

# **Chapter Eight. Conclusion, Contributions, Limitations and Future Work**

## **8.1 Chapter Overviews**

This final chapter aims to conclude the research effort by presenting a final discussion of the overall thesis chapters, followed by an examination of the research contributions. To date, very limited research pertaining to the use of OSAM in Saudi Arabia has been conducted, it is therefore believed that the findings of this research could contribute some insights to the existing marketing literature and methodology, as well as enlightening practitioners about shopping online. This is followed by a discussion of the limitations of the study and suggestions for future research directions, and finally the overall conclusion of this study will be drawn.

## **8.2 The Model**

As stated earlier in this research, the extended Online Shopping Acceptance Model (OSAM) model (see figure 8.1) was developed. Consequently, a number of hypotheses that relate to the new factor were added to the original model to determine its effect on the online shopping intention in Saudi Arabia to adapt to OSAM. This new factor is social media, which has an effect on online shopping acceptance.

The constructs of a new factor are the resultant of the structure used for the research model. The research did adopt thirty-five measurement items because they constituted the research survey with an aim of measuring the main research constructs. Thereafter, the relationships among various sets of variables were determined using confirmatory factor analysis of the research data. The results of the factor analysis supported confirmation of factorial validity for six of the main constructs, namely Motivation (M), shopping orientation (SO), online

## Chapter Eight. Conclusions

shopping (OS), online shopping experience (OE), online shopping intention (OSI) and social media (SM).

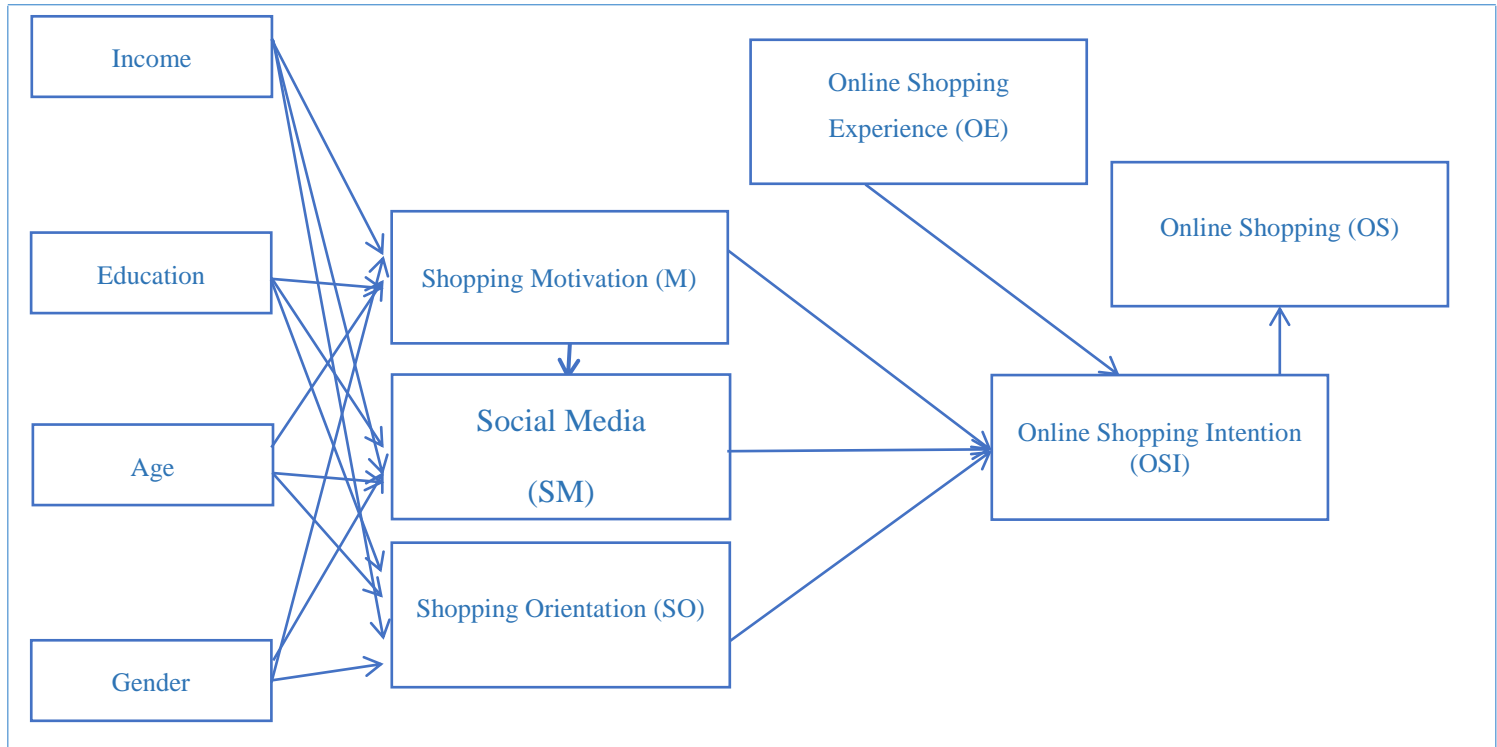

**Figure 8-1** The model

### 8.2.1 The Factors Effect on Online Shopping

Using the specific model, future online marketing strategies can be aligned with online consumer research. There are factors that affect the online shopping intention of the consumers and the online retailers are able to enhance their knowledge through the model. Retail stores can establish online marketing strategies to retain the present consumers and to gain new customers.

The results clearly indicate that online shopping intention is affected through status and authority values. There are factors such as adventure and sociality that do not affect the online shopping intention. During the online shopping process, the customers are interested in interactions with the online retailers, in terms of sociality. However, these online



## Chapter Eight. Conclusions

shoppers have not yet considered the importance of sociality and its critical ability to add value to the shopping experience.

According to the mentioned model, the consumers are constantly looking for convenience, lower prices, and a large selection of goods. This is specifically the case with online shopping and these factors are dominant in influencing the Saudi Arabian online shopping consumer.

The consumers who purchase online value the large variety available, the competitive prices, and the convenience associated with Internet shopping. Hence, it is essential for online retailers to extend competitive pricing as well as convenience to its potential customers. This would help gain the customer's attention. Social media platforms can be used to encourage the purchasing decisions of these consumers. Such activities are expected to create competition among retailers and with an enhanced level of competition, the search engines are also intelligent. These search engines have the ability to compare the various shopping retailer commodities or offerings and present the consumer with valuable information regarding the product.

At the same time, it is vital to assess the relationship between online shopping intention and shopping orientation. The loyalty and value of the customers is dependent on their entire shopping experience. The shopping environment can be made more suitable through Internet skills, such as the ease of computer use. Online shopper retention is created through interactive social media application designs. The product or service specifications and price must meet the requirements of the consumers for them to even consider making a purchase online.

Additionally, shopping orientation has a significant influence on online shopping intention. For online shopping intention, this shopping orientation is considered vital. Therefore, online shopping is accepted by the customers and they are highly motivated to use the service when the shopping orientation factors are present.

Results from the data also indicate that impulsive online shopping intention reacts to their interest. This can take place when a customer is exploring websites or social media channels and they see something they want and purchase it online.

Finally, the influence of demographics was not investigated in this research. Notably, this research only presented the demographic characteristics of people in Saudi Arabia.

There are several differing findings from this research. An example is that income did not have a positive effect on online shopping intention as compared to the findings of the OSAM by Zhou et. al. (2007) which suggested that gender plays an important role in online shopping intention.

### **8.2.2 Social Media Helps Online Shopping Acceptance Model**

Through the OSAM, it was observed that purchase intention is positively affected through social media. On social media platforms, sociability is experienced through associations and level of communality.

Various criteria can be used by organizations to assess a specific platform. It is essential to extract the social media platform in small communities that interest groups present. It is also important to understand the interactions among the people within the groups and examine if and how people are discussing the topic. Another question is which group members are contributors of valid and valuable content discussion. If any group influencers are present, who may be able to initiate an appropriate conversation. Are individuals sharing their purchasing experiences and other product information with fellow members of the group? By answering these questions, the retail stores or academic researchers can evaluate the relevance of social media platforms. It is also possible for organizations to establish their own groups and invite users to join, on a platform where there are no existing groups. These platforms may have a large variety of users who can be invited to this present group.

By establishing a new group, the organization can maintain complete control of the communication and advertising. Many organizations have established their own home page and have public profiles upon various social media platforms to obtain recognition. By creating a public profile, organizations are able to continuously update their activities, offers, and discussions. Through this valuable information, more users are attracted and participate in the discussion. If there is a large number of users on the platform, it is considered appropriate for use in social media. However, this does not guarantee that the user pay attention to all the available information or put it into use.

## Chapter Eight. Conclusions

To make sure that the customers are continuously engaged with the platform, the functions and features must be constantly updated. For this purpose, the organizations are required to enhance their attraction concepts to make sure the present customers are retained and new customers are also attracted. Organizations must always keep in mind the customer requirements when delivering the products to help establish a trustworthy relationship.

Taprial and Kanwar (2012) presented two steps which would help establish social media dependency of the consumer towards the organisation. Firstly, an organisation must advertise themselves using clear core values, a brand image, and other aspects. Through this clarity, they can be distinguished from other brands on social media. Users are always inclined to follow innovative, distinctive, and new brands. Secondly, the organization is required to establish long term customer relationships through social media. It is not only required to attract new customers but it is also a necessary factor in maintaining the loyalty of these customers, which is important in the eventual success of the organisation.

The transition is attained through two approaches. Organisations on social media must thoroughly assess the needs of the customers and satisfy these needs through strong communication. Also, organisation and consumer relationships are enhanced on social media through activities like attaining feedback and solving issues, problems, or queries.

Currently, communication is a routine activity and all consumers are engaged in this activity largely through the use of smartphones. Social media is able to provide valuable information regarding brands and it is the first platform accessed when a need arises. There are some in-built social media tools which are being used by organisations to send information to potential customers. These include the messages and newsletters that are sent regarding freebies, discounts, new products, and other aspects. This approach is quite similar to the online and offline product flyers. The only caveat is that the messages or emails could be referred to as junk information by some potential customers.

Therefore, new purchase channels are established by organisations through social media communities and group development. The consumers are provided with additional value in the long term and their purchasing decisions are complemented with valuable and reliable information.

### **8.3 Research Contribution**

The contributions of this study are divided into three subsections that address contributions to theory and practice.

#### **8.3.1 Theoretical Contributions**

There is substantial literature concerning online shopping because of previous studies that were conducted. However, whenever a study is conducted it provides an opening for more research through identifying information gaps. Existing studies are instrumental in the development of new research work. As such, it is important to note that this study was undertaken to examine an information gap concerning the Saudi Arabian market. It is valid to imply that a given answer to some solutions for information on a market gap, the topic contributes in theoretical, methodological, as well as in practical dimensions.

Theoretical dimensions can be pinned down into the new information that is available regarding the issue of online shopping. Online shopping as previously pointed out is not a new topic in research. However, this study was conducted to ensure that the information gathered provided solutions specific to the Saudi Arabian Market. The findings of this study are necessary because the information available on online shopping was completed for other countries and it is not statistically advisable to infer the results between countries because of the differences in a variety of aspects such as culture and other related factors. Inference of the results to another market would not have any meaningful importance because of these differences.

In the Saudi Arabia market, online shopping was determined based on nine hypotheses. The hypothesis stated that in Saudi Arabia, online shopping intention is related to the online shopping orientation. Consumers with high intention are likely to undertake the actual buying of products online. The other hypothesis was regarding online shopping experience that are directly related to online shopping intention with or without the mediating factors of perceived risks of products and financial risks. Moreover, there is a positive relationship between online shopping motivation and online shopping intention. A similar relationship can be observed between online shopping intention with social media and consumer

## Chapter Eight. Conclusions

demography. Lastly, the theoretical contribution played a role in social media through OSAM because it incorporates new factors that influence acceptance aside from what is traditionally stipulated.

### **8.3.2 Practical Contributions**

The following implications and suggestions are recommended for OASM practitioners.

#### ***8.3.2.1 Contributions to Marketing Strategies***

The results of this study demonstrated that the OSAM constructs have both a direct and indirect effect on shopping intention to purchase online. For that reason, the data from this study has potential for practical application in the development and management of online retail stores.

Shopping orientation is the most important construct that effects online shopping intention. Therefore, it is necessary for the managers of retail stores to place more emphasis on the price and quality of their goods.

In addition to these findings, there is a highly significant link between online shopping intention and online shopping through social media, which can be used for marketing purposes. This can result in increased sales. This outcome is one of the first to be empirically proven through quantitative research methods. Many initiatives were made over social media to promote brand recognition. This finding could propel firms that have been hesitant to invest in a structured acceptance plan with the aim of increasing commerce transactions. Additionally, users that engage in finding products are likely to share the information they find with friends, which attracts additional potential customers.

This research study was designed to ensure that it elaborated on the factors that influence online shopping intention, which in turn influences consumer's behaviour. It is also a subset of online shopping experience that is mediated by products and financial risks. Additionally, it is a subset of shopping motivation and shopping on social media. The

## Chapter Eight. Conclusions

information is valid and the analysis of results implies that the intention of a consumer is a dependent variable of social media factor.

Thus, for the online retailers in Saudi Arabia, they need to understand, appreciate, and implement the independent factors that support online shopping intention. The retailers are supposed to understand their target market and determine which of the independent variables apply to their specific case. An understanding of which variables work is likely to lead to increased online shopping intention. This will provide online shopping for a consumer to purchase a particular product. For example, in the case that a retailer realises a target market has a fear of making online purchases because of financial risk, the retailer can take measures to reduce the financial risks involved in making purchases for that target market in order to increase their purchase intention.

### ***8.3.2.2 Contributions to Understanding the Online shopping in Saudi Arabia***

This study has been designed to ensure that it explains the information available on the area of as a medium for commercial use and identifying consumers' rationales for adopting e-shopping. As noted by Al-Ghaith et. al. (2010), predicting the future of online shopping is subject to acknowledging the reasons that individuals to engage in online shopping. In the case of management, there are two perspectives. To begin with are the findings from this study point to the ability for managers to make investment decisions with ease. Additionally, the managers get the necessary information about decision making with regard to the development of Internet services that address the concerns and wants of the consumer. However, the outcomes of the research are based on extensive empirical investigation. The results are valid and applicable only for Saudi Arabia consumers. Although other countries were examined using OSAM previously, the results could not be assumed in the case of Saudi Arabia because of the existence of its differences such as culture, lifestyle, economics, and technological advancement.

### **8.4 Research Limitations and Future Research**

The information gathered in this study provides a more thorough understanding of the factors affecting online shopping acceptance in Saudi Arabia. However, there remains the need to follow up with further research to deepen the understanding of the effect of other factors on online shopping intention such as trust and smart mobile use. Thus, the findings of this study can be used to assist in the determination of consumer choices. The research undertaken in this study had limitations.

Firstly, it begs acknowledgement that businesses operating over the Internet and through social media are still at the level of infancy. Future research needs to investigate how firms can influence users to promote their products and services to others within their networks. The generalised analysis of social media is a drawback of this study. Future research needs to examine specific social media platforms and how they can be leveraged to achieve marketing objectives. Nevertheless, this study draws the conclusion that social media is an innovative mode of shopping as compared to traditional and electronic means of shopping.

Secondly, even though this study attempted to include a wide range of variables to explain online shopping acceptance in Saudi Arabia, it is clear that other factors associated with this complex phenomenon must be explained and potentially included in a more complete theoretical model. The finding of the direct relationships of external variables over and above the OSAM variables may be illustrative of the fact that in online shopping settings the OSAM needs to be extended to include other mediating beliefs. Future research could also seek to further extend models of technology acceptance to encompass other theoretical constructs relevant to e-shopping. It is essential, to investigate the role of trust and the use of smartphones.

Finally, this study was conducted based on gaps found in the literature concerning OSAM in Saudi Arabia. They were as follows:

- o Lack of empirical studies on OSAM in this context.
- o Lack of empirical studies on online shopping motivation in Saudi Arabia.

Another limitation is that this study used quantitative research methods only. Further research initiatives should include at least two different research methods. This could

## Chapter Eight. Conclusions

include a combination of quantitative and qualitative research for the collection of data and for analysis. In Saudi Arabia, this could include a mix of interviews and questionnaires. If future research studies use questionnaires, these questionnaires should be brief in order to motivate participants to complete them. There was a challenge with the use of questionnaires for this study because approximately nineteen percent of participants did not complete them due to the length involved in filling it out. Most participants who did not fill out the long questionnaires did not have enough time to answer all questions. The author of this study propose that the research methodology should to incorporate more than one specific tool to ensure an appropriate understanding of the information gathered.

### **8.5 Summary**

In conclusion, the dissertation provided an overall framework that can assist retail manager in the Saudi Arabian market to make decisions with ease about online shopping. This dissertation was position to provide valuable information about what constitutes online shopping intention. This was intended so that managers of online retail stores are able to work on the issues raised within this dissertation to attract more consumers to buy their produces. This will consequently result in more sales. Furthermore, it shows the managers how they can take advantage of social media to increase online shopping intention. Therefore, the study is also relevant to create new academic information to add to the literature on online shopping as well as practical solutions to problems that are troubling online businesses in Saudi Arabia.



# References

- AAG (Arab Advisor Group) 2012, The volume of electronic commerce for individuals in Saudi Arabia and United Arab Emirates, Kuwait, Lebanon Exceeded 4.87 billion U.S. dollars during the year 2012, Arab Advisor Group, viewed 22 Nov 2013, <http://www.arabadvisors.com/arabic/Pressers/presser-040208.htm>.
- Abed, S., Dwivedi, Y., & Williams, M. (2015). Social Commerce Adoption by Saudi Consumers: A Conceptual Model.
- Adler, M. (2010). A study of Marketing and Online Marketing Tools which improve online success.
- Agag, G., & El-Masry, A. A. (2016). Understanding consumer intention to participate in online travel community and effects on consumer intention to purchase travel online and WOM: An integration of innovation diffusion theory and TAM with trust. *Computers in Human Behavior*, 60, 97-111.
- Agwu, E. & Murray, P. (2015). Empirical Study of Barriers to Electronic Commerce Uptake by SMEs in Developing Economies. *International Journal Of Innovation In The Digital Economy*, 6(2), 1-19.
- Ahire, S. L., & Devaraj, S. (2001). An empirical comparison of statistical construct validation approaches. *IEEE Transactions on Engineering Management*, 48(3), 319-329.
- Ahmed, S. & Bahaziq, Y. (2013). *Online shopping in Saudi Arabia*. *Arab Journal of Administrative Sciences*, 20(1), 125-149.
- Ajzen, I. (1991). The theory of planned behavior. *Organizational Behavior And Human Decision Processes*, 50(2), 179-211.
- Ajzen, I. (2011). Design and evaluation guided by the theory of planned behavior. *Social psychology and evaluation*, 74-100.
- Ajzen, I., & Fishbein, M. (1980). Understanding attitudes and predicting social behaviour.
- Al-Adwan, A., Al-Adwan, A., & Smedley, J. (2013). Exploring students acceptance of e-learning using Technology Acceptance Model in Jordanian universities. *International Journal of Education and Development using Information and Communication Technology*, 9(2), 4.

- ALAM, A., MALIK, O. M., HADI, N. U., & GAADAR, K. (2016). Barriers of Online Shopping in Developing Countries: Case Study of Saudi Arabia. *European Academic Research*, 3(12), 12957-12971.
- AlAwadhi, S., & Morris, A. (2008, January). The Use of the UTAUT Model in the Adoption of E-government Services in Kuwait. In *Hawaii International Conference on System Sciences, Proceedings of the 41st Annual* (pp. 219-219). Ieee.
- Alevesson, M. & Skoldberg, K. (2009). *Reflexive Methodology*. 2<sup>nd</sup> Ed. SAGE Pub Ltd.
- Alfuraih, S. (2008, April). E-commerce and e-commerce fraud in Saudi Arabia: A case study. In *Information Security and Assurance, 2008. ISA 2008. International Conference on* (pp. 176-180). IEEE.
- Al-Ghaith, W., Sanzogni, L., & Sandhu, K. (2010). Factors influencing the adoption and usage of online services in Saudi Arabia. *EJISDC: The Electronic Journal on Information Systems in Developing Countries*, (40), 1.
- AlGhamdi, R., Drew, S., & Alkhalaf, S. (2012). Government initiatives: The missing key for e-commerce growth in KSA. *arXiv preprint arXiv:1211.2398*.
- AlGhamdi, R., Nguyen, A., Nguyen, J., & Drew, S. (2011). Factors Influencing Saudi Customers' Decisions to Purchase from Online Retailers in Saudi Arabia: A Quantitative Analysis. In *IADIS International Conference e-commerce* (pp. 153-161).
- Al-Ghamdi, R., Nguyen, J., Nguyen, A., & Drew, S. (2012). Factors influencing e-commerce adoption by retailers in Saudi Arabia: A quantitative analysis. *International Journal of Electronic Commerce Studies*, 3(1), 83-100.
- Al-Gahtani, S. S. (2014). Empirical investigation of e-learning.
- Alharbi, S and Drew, S. (2014). Using the Technology Acceptance Model in Understanding Academics' Behavioural Intention to Use Learning Management Systems. *International Journal of Advanced Computer Science and Applications*, Vol. 5, No. 1, 2014.
- Aljazira Capital, 2016. Oil and Gas. Viewed on 1 October 2016. Available at: <http://www.aljaziracapital.com.sa/report.asp?rep=e>
- Al-Mamary, Y. H., Al-nashmi, M., Hassan, Y. A. G., & Sana'a, Y. (2016). A Critical Review of Models and Theories in Field of Individual Acceptance of

- Technology. *International Journal of Hybrid Information Technology*, 9(6), 143-158.
- AlMunajjed, M., Sabbagh, K., & Insight, I. C. (2011). Youth in GCC countries: meeting the challenge. *Booz & Company Inc.*
- Al-maghrabi, T., & Dennis, C. (2009). Driving online shopping: Spending and behavioral differences among women in Saudi Arabia.
- Al-Maghrabi, T., & Dennis, C. (2011). What drives consumers' continuance intention to e-shopping? Conceptual framework and managerial implications in the case of Saudi Arabia. *International Journal of Retail & Distribution Management*, 39(12), 899-926.
- Al-Maghrabi, T., Dennis, C., Halliday, S. V., & BinAli, A. (2011). Determinants of customer continuance intention of online shopping. *International Journal of Business Science and Applied Management*, 6(1), 41-65.
- Al-Mowalad, A., & Putit, L. (2012). Factors that influence Saudi consumers behavior to make online purchase. In *International Conference on Management, Behavioral Sciences and Economics Issues*.
- Al-Otaibi, M. B., & Al-Zahrani, R. M. (2003). E-commerce adoption in Saudi Arabia: an evaluation of commercial organizations' web sites. *International Conference on Information Technology in Asia (CITA)*.
- Al-Rasheed, M. (2010). *A history of Saudi Arabia*. Cambridge University Press.
- Alreck, P., & Settle, R. B. (2002). Gender effects on Internet, catalogue and store shopping. *Journal of Database Marketing & Customer Strategy Management*, 9(2), 150-162.
- Al-Solbi, A. N. H., & Al-Harbi, S. (2008). An exploratory study of factors determining e-government success in Saudi Arabia. *Communications of the IBIMA*, 4(25), 188-192.
- Al-Somali, S. A., Gholami, R., & Clegg, B. (2009). An investigation into the acceptance of online banking in Saudi Arabia. *Technovation*, 29(2), 130-141.
- Alsuwat, M. O. (2013). *Online buying behavior in Saudi Arabia and New Zealand: a comparative case study* (Doctoral dissertation, Auckland University of Technology).
- Alvesson, M., & Sköldbberg, K. (2009). *Reflexive methodology: New vistas for qualitative research*. Sage.

- Amaro, S., & Duarte, P. (2013). Online travel purchasing: A literature review. *Journal of Travel & Tourism Marketing*, 30(8), 755-785.
- Ambali, A. R. (Ed.). (2014). *ICT Adoption and Application in the Malaysian Public Sector*. IGI Global.
- An, L., Han, Y., & Tong, L. (2016). Study on the Factors of Online Shopping Intention for Fresh Agricultural Products Based on UTAUT2.
- Andrews, D., Nonnecke, B., & Preece, J. (2003). Electronic Survey Methodology: A Case Study in Reaching Hard-to-Involve Internet Users. *International Journal of Human-Computer Interaction*, 16(2), 185-210.
- Anisimova, T. (2013). Evaluating the impact of corporate brand on consumer satisfaction. *Asia Pacific Journal Of Marketing And Logistics*, 25(4), 561-589.
- Annamalah, S. Adoption and Usage of Internet Banking 'A Technological Perspective'. *SSRN Electronic Journal*.
- Arbuckle, J. L. (2003). 5.0 Update to the Amos user's guide. SmallWaters Corporation, Chicago, IL.
- Armitage, C. J., & Conner, M. (2001). Efficacy of the theory of planned behaviour: A meta-analytic review. *British journal of social psychology*, 40(4), 471-499.
- Arno, C. (2012). *Worldwide Social Media Usage Trends in 2012*. Viwed on 15 October 2015. Retrieved from <http://searchenginewatch.com/article/2167518/Worldwide-Social-Media-Usage-Trends-in-2012>
- Arnold, M. & Reynolds, K. (2003). Hedonic shopping motivations. *Journal Of Retailing*, 79(2), 77-95. [http://dx.doi.org/10.1016/s0022-4359\(03\)00007-1](http://dx.doi.org/10.1016/s0022-4359(03)00007-1).
- Asfoura, E., Jamous, N., Kassam, G., & Dumke, R. (2009). E-mall as solution for marketing the federated ERP components on the basis of web services. *International Review of Business Research Papers*, 5(4), 478-490.
- Ashraf, A., Thongpapanl, N., & Auh, S. (2014). The Application of the Technology Acceptance Model Under Different Cultural Contexts: The Case of Online Shopping Adoption. *Journal Of International Marketing*, 22(3), 68-93.
- Asiegbu, I. F., Powei, D. M., & Iruka, C. H. (2012). Consumer Attitude: Some Reflections on Its Concept, Trilogry, Relationship with Consumer Behavior, and Marketing Implications. *European Journal of Business and Management*, 4(13), 38-50.

- Asraar Ahmed, K. A. (2015). Utilitarian and hedonic motives of university students in their online shopping-a gender based examination. *Global Management Review*, 9(4).
- A.T. Kearnet. (2016). Global Cities 2016.
- Bach, M. P., Čeljo, A., & Zoroja, J. (2016). Technology Acceptance Model for Business Intelligence Systems: Preliminary Research. *Procedia Computer Science*, 100, 995-1001.
- Bahaddad, A. A., Drew, S., Houghton, L., & Alfarraj, O. A. (2015). Factors attracting online consumers to choose e-Malls for e-procurement in Saudi Arabia. *Enterprise Information Systems*, 1-32.
- Bagozzi, R.P., & Yi, Y. (2012). Specification, evaluation, and interpretation of structural equation models. *Journal of the Academy of Marketing Science*, 40(1), 1-27.
- Bakos, J. Y. (1997). Reducing buyer search costs: Implications for electronic marketplaces. *Management science*, 43(12), 1676-1692.
- Baron, R. & Kenny, D. (1986). The moderator–mediator variable distinction in social psychological research: Conceptual, strategic, and statistical considerations. *Journal Of Personality And Social Psychology*, 51(6), 1173-1182.
- Bateman, B. T., Berman, M. F., Riley, L. E., & Leffert, L. R. (2010). The epidemiology of postpartum hemorrhage in a large, nationwide sample of deliveries. *Anesthesia & Analgesia*, 110(5), 1368-1373.
- Bentler, P. & Bonett, D. (1980). Significance tests and goodness of fit in the analysis of covariance structures. *Psychological Bulletin*, 88(3), 588-606.
- Bernard, H. R. (2011). *Research methods in anthropology: Qualitative and quantitative approaches*. Rowman Altamira.
- Bhatnagar, A., & Ghose, S. (2004). Online information search termination patterns across product categories and consumer demographics. *Journal of Retailing*, 80(3), 221-228.
- Bhatti, T. (2015). Exploring factors influencing the adoption of mobile commerce. *The Journal of Internet Banking and Commerce*.
- Bhattacharjee, A. (2012). *Social science research: principles, methods, and practices*.
- Biemans, M., Swaak, J., Hettinga, M., & Schuurman, J. G. (2005, November). Involvement matters: the proper involvement of users and behavioural theories

- in the design of a medical teleconferencing application. In *Proceedings of the 2005 international ACM SIGGROUP conference on Supporting group work* (pp. 304-312). ACM.
- Bigne-Alcaniz, E., Aldas-Manzano, J., Andreu-Simo, L., & Ruiz-Mafe, C. (2009). Business-to-Business e-commerce adoption and perceived benefits: evidence from small and medium Spanish enterprises. *International Journal of Electronic Business*, 7(6), 599-624.
- Bigné, J. E., Sánchez, I., & Andreu, L. (2009). The role of variety seeking in short and long run revisit intentions in holiday destinations. *International Journal of Culture, Tourism and Hospitality Research*, 3(2), 103-115.
- Bo, D., Sandra, F., & Wi-Suk, K. (2014). THE IMPACT OF ONLINE SHOPPING EXPERIENCE ON RISK PERCEPTIONS AND ONLINE PURCHASE INTENTIONS: DOES PRODUCT CATEGORY MATTER? *Journal of Electronic Commerce Research*, 13-24.
- Bobbitt, L. M., & Dabholkar, P. A. (2001). Integrating attitudinal theories to understand and predict use of technology-based self-service: the internet as an illustration. *International Journal of Service Industry Management*, 12(5), 423-450.
- Bollen, K. A., & Ting, K. F. (2007). Confirmatory tetrad analysis.
- Bough, B. B., Agresta, S., & Miletsky, J. I. (2010). Perspectives on Social Media Marketing.
- Brashear, T. G., Kashyap, V., Musante, M. D., & Donthu, N. (2009). A profile of the Internet shopper: Evidence from six countries. *Journal of Marketing Theory and Practice*, 17(3), 267-282.
- Breazeale, M. (2009). „An Assessment of Electronic Word-of-Mouth Research “. *International Journal of Market Research*, 51(3), 297-318.
- Bollen, 1989, Overall fit in covariance structure models: Two types of sample size effects. *Psychological Bulletin*, 107, 256-259.
- Brdese, H., Corbitt, B., Pittayachawan, S., & Alsaggaf, W. (2012, July). Organisational culture and adoption of electronic commerce: A study of the Saudi Arabian tourism market. In *Computer Science & Education (ICCSE), 2012 7th International Conference on* (pp. 857-862).

- Brislin, R. W. (1986). Research instruments. *Field methods in cross-cultural research: Cross-cultural research and methodology series*, 8, 137-164.
- Brosdahl, D. J., & Almousa, M. (2013). Risk perception and internet shopping: comparing United States and Saudi Arabian consumers. *Journal of Management and Marketing Research*, 13, 1.
- Brown, J., Broderick, A. J., & Lee, N. (2007). Word of mouth communication within online communities: Conceptualizing the online social network. *Journal of Interactive Marketing*, 21 (3), 2–20.
- Brown, J. D. (2008). 19 Research Methods for Applied Linguistics: Scope, Characteristics, and Standards. *The handbook of applied linguistics*, 476.
- Bruwer, J., Saliba, A., & Miller, B. (2011). Consumer behaviour and sensory preference differences: implications for wine product marketing. *Journal of Consumer Marketing*, 28(1), 5-18.
- Bryman, A. (2012) *Social research methods*, Oxford: Oxford University Press.
- Bryman, A., & Bell, E. (2011). *Business Research Methods 3e*. Oxford University Press.
- Bughin, J., Doogan, J., & Vetvik, O. (2011). A new way to measure word-of-mouth marketing. *McKinsey Quarterly*, viewed 22 Nov 2014  
[http://www.mckinseyquarterly.com/A\\_new\\_way\\_to\\_measure\\_word-of-mouth\\_marketing\\_2567](http://www.mckinseyquarterly.com/A_new_way_to_measure_word-of-mouth_marketing_2567)
- Burrell, G., & Morgan, G. (1979). Sociological paradigms and organisational analysis. *Elements of the sociology of corporate life..The World Factbook — Central Intelligence Agency*. (2014). *Cia.gov*.
- Burns, A. & Bush, R. (2006). *Marketing Research. Globalization. Vol.1, No.7..*
- Butt, I., Tabassam, S., Chaudhry, N. G., & Nusair, K. (2016). USING TECHNOLOGY ACCEPTANCE MODEL TO STUDY ADOPTION OF ONLINE SHOPPING IN AN EMERGING ECONOMY. *Journal of Internet Banking and Commerce*, 21(2), 1.).
- Byrne, B.M. (2010). *Structural Equation Modeling with AMOS: Basic Concepts, Applications, and Programming* (2nd ed.). New York: Routledge Taylor & Francis Group.

- Caine, S., Lane, T., May, P., Jakob, C., Siems, S., Manton, M., & Pinto, J. (2013). Statistical Assessment of Tropical Convection-Permitting Model Simulations Using a Cell-Tracking Algorithm. *Mon. Wea. Rev.*, *141*(2), 557-581.
- Chang, H.H., Wang, Y., and Yang, W. (2009). The impact of e service quality, customer satisfaction and loyalty on e marketing: Moderating effect of perceived value. *Total Quality Management*, *20*(4), 423-443.
- Chang, Y. S., & Pak, D. H. (2017). Warren Buffett Value Indicator vs. GDP Size— is the Relationship Superlinear?.
- Chatfield, C. (1985). The initial examination of data. *Journal of the Royal Statistical Society. Series A (General)*, 214-253.
- Cheal, J. (2012). Science, Philosophy and NLP. *Neuro Linguistic Programming*, 29.
- Chen, Chun-An, (2009). "Information-oriented Online Shopping Behavior in Electronic Commerce Environment", *Journal of Software*, Vol. 4, No. 4, pp. 307-314
- Cheng, D., Liu, G., Song, Y. F and Qian, C. (2008). Adoption of Internet Banking: An Integrated Model". *Proceeds of the 4th International Conference on Wireless Communications, Networking and Mobile Computing*, 12-14 Oct. 2008, Dalian.
- Chen, L., Gillenson, M., & Sherrell, D. (2002). Enticing online consumers: an extended technology acceptance perspective. *Information & Management*, *39*(8), 705-719.
- Chen, W. (2014). Contextual Innovation and R&D Strategy: An Analysis of the Competitive Advantage of Social Media Companies in China.
- Chen, Y., Kishore, S., & Li, J. (2006, April). Wireless diversity through network coding. In *Wireless Communications and Networking Conference, 2006. WCNC 2006. IEEE* (Vol. 3, pp. 1681-1686). IEEE.
- Child, J. (1973). Predicting and Understanding Organization Structure. *Administrative Science Quarterly*, *18*(2), 168.
- Childers, T., Carr, C., Peck, J., & Carson, S. (2001). Hedonic and utilitarian motivations for online retail shopping behavior. *Journal Of Retailing*, *77*(4), 511-535.
- Chiu, C., Wang, E., Fang, Y., & Huang, H. (2014). Understanding customers' repeat purchase intentions in B2C e-commerce: the roles of utilitarian value, hedonic value and perceived risk. *Information Systems Journal*, *24*(1), 85-114.



- Cho, J. (2004). Likelihood to abort an online transaction: influences from cognitive evaluations, attitudes, and behavioral variables. *Information & Management*, 41(7), 827-838.
- Choi, J. & Geistfeld, L. (2004). A cross-cultural investigation of consumer e-shopping adoption. *Journal Of Economic Psychology*, 25(6), 821-838. <http://dx.doi.org/10.1016/j.joep.2003.08.006>
- Chong, A., Ooi, K., Lin, B., & Bao, H. (2012). An empirical analysis of the determinants of 3G adoption in China. *Computers In Human Behavior*, 28(2), 360-369.
- Churchill, G. A. & Iacobucci, D.(2002). *Marketing Research-Methodological Foundations*.
- Cimperman, M., Brenčič, M. M., & Trkman, P. (2016). Analyzing older users' home telehealth services acceptance behavior—applying an Extended UTAUT model. *International journal of medical informatics*, 90, 22-31.
- Citrin, A. V., Stem, D. E., Spangenberg, E. R., & Clark, M. J. (2003). Consumer need for tactile input: An internet retailing challenge. *Journal of Business research*, 56(11), 915-922.
- Cohen, J. (1988). *Statistical power analysis for the behavioral sciences* (2nd ed.). Hillsdale, NJ: Erlbaum
- Coghlan, D., & Brannick, T. (2014). *Doing action research in your own organization*. Sage.
- Collis, J. & Hussey, R. (2009) *Business Research: A Practical Guide for Undergraduate and Postgraduate Students*. 2<sup>nd</sup> Ed. Basingstoke: Palgrave Macmillan.
- Communications and Information Technology Commission. (2016). *Internet Usage Study in the Kingdom of Saudi Arabia* Communications and Information Technology Commission, Riyadh.
- Constantinos N., Phellas, A. & Clive S. (2003), *Researching Society and Culture*. 3<sup>rd</sup> Edition.
- Cooper, D. & Schindler, P. (2008). *Business research methods, 10th edition, London. UK: McGrawHill*.
- Coppel, J. (2000). *E-commerce*.

- Costello, A. B., & Osborne, J. W. (2011). Best practices in exploratory factor analysis: four recommendations for getting the most from your analysis. *Pract Assess Res Eval* 2005; 10. URL <http://pareonline.net/getvn.asp>, 10(7).
- County, M. (2014). Is Gen Y really breaking up with the car?. *development*, 501, 2
- Cowart, K. O., & Goldsmith, R. E. (2007). The influence of consumer decision-making styles on online apparel consumption by college students. *International Journal of Consumer Studies*, 31(6), 639-647.
- Crano, W., Brewer, M., & Lac, A. (2005). *Principles and methods of social research*. Psychology Press.
- Creswell, J. W. (2013). *Research design: Qualitative, quantitative, and mixed methods approaches*. Sage publications.
- Creswell, J. W., & Clark, V. L. P. (2007). Designing and conducting mixed methods research.
- Dahlén, M., Lange, F., & Smith, T. (2009). *Marketing Communications: A Brand Narrative Approach John Wiley and Sons, 2009. 584 s. ISBN 978-047031-992-5*.
- Dai, B., Forsythe, S., & Kwon, W. S. (2014). The impact of online shopping experience on risk perceptions and online purchase intentions: does product category matter?. *Journal of Electronic Commerce Research*, 15(1), 13.
- Dann, S. (2010). Redefining social marketing with contemporary commercial marketing definitions. *Journal of Business Research*, 63(2), 147-153.
- Davis, F. D., Bagozzi, R. P., & Warshaw, P. R. (1992). Extrinsic and intrinsic motivation to use computers in the workplace1. *Journal of applied social psychology*, 22(14), 1111-1132.
- Denscombe, M. (2003). The good research guide for small-scale social research projects \_.
- Devaraj, S., Fan, M., & Kohli, R. (2002). Antecedents of B2C channel satisfaction and preference: validating e-commerce metrics. *Information systems research*, 13(3), 316-333.
- Dillon, S., Buchanan, J., & Al-Otaibi, K. (2014). Perceived risk and online shopping intention: a study across gender and product type. *International Journal of E-Business Research (IJEER)*, 10(4), 17-38.

- Dittmar, H., Long, K., & Meek, R. (2004). Buying on the Internet: Gender differences in on-line and conventional buying motivations. *Sex roles, 50*(5-6), 423-444.
- Donthu, N., & Garcia, A. (1999). The internet shopper. *Journal of advertising research, 39*(3), 52-52.
- Doolin, B., Dillon, S., Thompson, F., & Corner, J. L. (2005). Perceived Risk, the Internet Shopping Experience and Online Purchasing Behavior: A New Zealand Perspective. *Journal of Global Information Management (JGIM), 13*(2), 66-88.
- Dunteman, G. H. (1989). *Principal components analysis* (No. 69). Sage.
- Easterby-Smith, M., Thorpe, R. Jackson, P. & Lowe, A. (2008) *Management Research*. 3<sup>rd</sup> edn. Sage: London.
- El-Ansary, O., & Roushdy, A. S. (2013). Factors Affecting Egyptian Consumers' Intentions for Accepting Online Shopping.
- El-Masry, A. A., & Agag, G. (2016). Why do consumers trust online travel websites? Drivers and outcomes of consumer trust towards online travel websites.
- Ess, C. 2014. *Culture, Technology, Communication: Towards an Intercultural Global Village*. Suny Press.
- Evans, J. D., Saegerman, C., Mullin, C., Haubruge, E., Nguyen, B. K., Frazier, M., ... & Tarpy, D. R. (2009). Colony collapse disorder: a descriptive study. *PloS one, 4*(8), e6481.
- Fakultas, E. (2014). Theory of Reasoned Action.
- Farrell Patrick, H. (2010). High Resolution Two-Dimensional Electrophoresis of Proteins. *J Biol Chem, 250*(10), 4007-4021.
- Fang, J., Wen, C., George, B., & Prybutok, V. R. (2016). CONSUMER HETEROGENEITY, PERCEIVED VALUE, AND REPURCHASE DECISION-MAKING IN ONLINE SHOPPING: THE ROLE OF GENDER, AGE, AND SHOPPING MOTIVES. *Journal of Electronic Commerce Research, 17*(2), 116.
- Flick, K. L. (2009). *Assessing consumer acceptance of online shopping: Examining factors affecting purchase intentions*. ProQuest.
- Florian, L., Black-Hawkins, K., & Rouse, M. (2016). *Achievement and inclusion in schools*. Routledge.

- Fox, J. (1984). *Linear Statistical Models and Related Methods: With Applications to Social Research*. New York: Wiley
- Fram, E. H., & Grady, D. B. (1995). Internet buyers: Will the surfers become buyers? *DIRECT MARKETING-GARDEN CITY-*, 58, 63-63.
- Fuchs, C., & Diamantopoulos, A. (2009). Using single-item measures for construct measurement in management research: conceptual issues and application guidelines. *Die Betriebswirtschaft*, 69(2), 195.
- Furnham, A. (2005). *The psychology of behaviour at work: The individual in the organization*. Psychology Press.
- Gall, M. D., Borg, W. R., & Gall, J. P. (1996). *Educational research: An introduction*. Longman Publishing.
- Gefen, D., Karahanna, E. & Straub, D. (2005). Trust and TAM in online shopping: an integrated model. *MIS Quarterly*, Vol. 27, No.1, pp. 51–90.
- Gentile, C., Spiller, N., & Noci, G. (2007). How to sustain the customer experience:: An overview of experience components that co-create value with the customer. *European Management Journal*, 25(5), 395-410.
- Gephart, R. P. (2004). Qualitative research and the Academy of Management Journal. *Academy of Management Journal*, 47(4), 454-462.
- George, H. F., (2002), “Influences on the Internet to make purchases”, *Internet Research*, Vol. 12 No. 2, pp. 165-80.
- Giovanis, A. N., Binioris, S., & Polychronopoulos, G. (2012). An extension of TAM model with IDT and security/privacy risk in the adoption of internet banking services in Greece. *EuroMed Journal of Business*, 7(1), 24-53.
- Girard, R., Oughourlian, J., & Lefort, G. (2003). *Things Hidden since the Foundation of the World*. A&C Black.
- GMI. (2016). Gulf Market International. Viewed on November 2016. Available at: <http://www.gulfmarketsintl.com/?p=1557>
- Godes, D., & Mayzlin, D. (2004). Using online conversations to study word-of-mouth communication. *Marketing science*, 23(4), 545-560.
- Goldsmith, P. B. (2002). On the equivalence of causal LTI iterative learning control and feedback control. *Automatica*, 38(4), 703-708.
- Gong, W. (2009). National culture and global diffusion of business-to-consumer e-commerce. *Cross cultural management: an international journal*, 16(1), 83-101.

- Grabner-Kräuter, S., & Kaluscha, E. A. (2003). Empirical research in on-line trust: a review and critical assessment. *International Journal of Human-Computer Studies*, 58(6), 783-812.
- Grunert, K. G., & Ramus, K. (2005). Consumers' willingness to buy food through the internet: A review of the literature and a model for future research. *British Food Journal*, 107(6), 381-403.
- Guba, E. G., & Lincoln, Y. S. (1994). Competing paradigms in qualitative research. *Handbook of qualitative research*, 2(163-194), 105.
- Guo, Y., Barnes, S. J., Le-Nguyen, K., & Jia, Q. (2016). A THEORETICAL APPROACH TO ONLINE REVIEW SYSTEMS: AN INFLUENCE OF REVIEW COMPONENTS MODEL.
- Grabner-Kräuter, S., & Kaluscha, E. A. (2003). Empirical research in on-line trust: a review and critical assessment. *International Journal of Human-Computer Studies*, 58(6), 783-812.
- Gyamfi, G.D. (2014). Evaluating Entrepreneurship Education as a Tool for Economic Growth: The Ghanaian Experience, *British Journal of Education, Society & Behavioural Science*, Vol. 4(3), 318-335
- Ha, S., & Stoel, L. (2012). Online apparel retailing: roles of e-shopping quality and experiential e-shopping motives. *Journal of Service Management*, 23(2), 197-215.
- Hair, J.F., Black, W.C., Babin, B., & Anderson, R.E. . . (2010). *Multivariate data analysis* (7th ed.). New Jersey: Prentice Hall.
- Hankins, M., French, D., & Horne, R. (2000). Statistical guidelines for studies of the theory of reasoned action and the theory of planned behaviour. *Psychology and Health*, 15(2), 151-161
- Hansen, T., Jensen, J. M., & Solgaard, H. S. (2004). Predicting online grocery buying intention: a comparison of the theory of reasoned action and the theory of planned behavior. *International Journal of Information Management*, 24(6), 539-550.
- Hanson, D., & Grimmer, M. (2007). The mix of qualitative and quantitative research in major marketing journals, 1993-2002. *European Journal of Marketing*, 41(1/2), 58-70.
- Haque A, Sadeghzadeh J, Khatibi A (2006). Identifying potentiality online sales in malaysia: A study on customer relationships online shopping. *J. Appl. Bus.*

Res., 22(4):119.

- Hardy, M. & Bryman A. (Eds.)(2004). Handbook of Data Analysis. In *Forum Qualitative Sozialforschung/Forum: Qualitative Social Research* (Vol. 7, No. 2).
- Hawkins, M. (1997). *Social Darwinism in European and American thought, 1860-1945: nature as model and nature as threat*. Cambridge University Press.
- Healey, J. F. (2012). *The Essentials of Statistics: A Tool for Social Research*. Cengage Learning.
- Heerink, M., Kroese, B., Evers, V., & Wielinga, B. (2009, September). Measuring acceptance of an assistive social robot: a suggested toolkit. In *Robot and Human Interactive Communication, 2009. RO-MAN 2009. The 18th IEEE International Symposium on* (pp. 528-533). IEEE.
- Heinrichs, J. H., Al-Aali, A., Lim, J. S., & Lim, K. S. (2016). Gender-Moderating Effect on e-Shopping Behavior: A Cross-Cultural Study of the United States and Saudi Arabia. *Journal of Global Marketing*, 1-13.
- Hernández, B., Jiménez, J., & José Martín, M. (2011). Age, gender and income: do they really moderate online shopping behaviour?. *Online Information Review*, 35(1), 113-133.
- Hidayat-ur-Rehman, I., Mokhtar, S. A., & Katan, H. (2016). An Empirical Analysis of Consumers' Continuance Intention Towards Online Shopping. *Mediterranean Journal of Social Sciences*, 7(5), 95.
- Hill, R., Fishbein, M., & Ajzen, I. (1977). Belief, Attitude, Intention and Behavior: An Introduction to Theory and Research. *Contemporary Sociology*, 6(2), 244.
- Hirschheim, R., & Klein, H. K. (1994). Realizing emancipatory principles in information systems development: the case for ETHICS. *MIS quarterly*, 83-109.
- Hitchcock, D. (2012). Deductive and inductive: Types of validity, not types of argument. *Informal Logic*, 2(3).
- Hoffman, D. L., Novak, T. P., & Peralta, M. (1999). Building consumer trust online. *Communications of the ACM*, 42(4), 80-85.
- Hofstede, G. (1991). Cultures and organizations. Intercultural cooperation and its importance for survival. *Software of the mind*. London: Mc Iraw-Hill.

- Holmes-Smith, P. (2011). *Advanced Structural Equation Modelling using Amos*: Australian Consortium for Social and Political Research Incorporated, Monash University, Clayton.
- Hooper, D., Coughlan, J., & Mullen, M. R. (2008). Structural Equation Modelling: Guidelines for Determining Model Fit. *Electronic Journal of Business Research Methods*, 6(1), 53-60.
- Horkheimer, M., & Adorno, T. W. (2002). Dialectic of enlightenment: Philosophical fragments (E. Jephcott, Trans.). *Cultural memory in the present*. Palo Alto, California: Stanford University Press. (Original work published 1947).
- Horky, A., & Collier, J. (2016). Exploring Showrooming Experiences at Small Retailers. In *Celebrating America's Pastimes: Baseball, Hot Dogs, Apple Pie and Marketing?* (pp. 863-866). Springer International Publishing.)
- Horrigan, J. A. (2008). Online shopping. *Pew Internet & American Life Project Report*, 36, 1-24.
- Howe, W. (2012). *A brief history of the Internet*. Retrieved from <http://walthowe.com/navnet/history.html>
- Hoyle, M. (2000). *U.S. Patent No. 6,141,010*. Washington, DC: U.S. Patent and Trademark Office.
- Hromas, R., Gray, P. W., Chantry, D., Godiska, R., Krathwohl, M., Fife, K., ... & Cooper, S. (1997). Cloning and characterization of exodus, a novel  $\beta$ -chemokine. *Blood*, 89(9), 3315-3322.
- Hsu, M. H., Chuang, L. W., & Hsu, C. S. (2014). Understanding online shopping intention: the roles of four types of trust and their antecedents. *Internet Research*, 24(3), 332-352.
- Hu, L. T., & Bentler, P. M. (1998). Fit indices in covariance structure modeling: Sensitivity to underparameterized model misspecification. *Psychological methods*, 3(4), 424.
- Huang, M. H. (2003). Modeling virtual exploratory and shopping dynamics: an environmental psychology approach. *Information & Management*, 41(1), 39-47.
- Informix TechInfo Center: - IBM. (2000). Developing Restful Web Application for Liberty in CICS.

- Internet Society (2016). Brief History of Internet. Retrieved from <http://www.internetsociety.org/internet/what-internet/history-internet/brief-history-internet>
- Internet World Statas, (2016). Internet Users in the World in Regions (June, 2016). Retrieved from <http://www.internetworldstats.com/stats.htm>
- Ioană, E., & Stoica, I. (2014). Social media and its impact on consumers behavior. *International Journal of Economic Practices and Theories*, 4(2), 295-303.
- Jarol, M., & Richard, R. (1995). Empirical political analysis research methods in political science.
- Jarvenpaa, S. L., Tractinsky, N., & Vitalec, M. (2000). Consumer trust in an Internet store. *Information Technology and Management*, 1, 45-71.
- Jiang, P. (2009). Consumer Adoption of Mobile Internet Services: An Exploratory Study. *Journal Of Promotion Management*, 15(3), 418-454.
- Joines, J. L., Scherer, C. W., & Scheufele, D. A. (2003). Exploring motivations for consumer Web use and their implications for e-commerce. *Journal of consumer marketing*, 20(2), 90-108.
- Jöreskog, K.G., & Sörbom, D. (1984). LISREL VI: Analysis of Linear Structural Relationships by Maximum Likelihood, Instrumental Variables, and Least Squares Methods (3rd ed.). Mooresville: Ind: Scientific Software.
- Jung, M. L., & Loria, K. (2010). Acceptance of Swedish e-health services. *Journal of multidisciplinary healthcare*, 3, 55.
- Jusoh, Z. M., & Ling, G. H. (2012). Factors influencing consumers' attitude towards e-commerce purchases through online shopping. *International Journal of Humanities and Social Science*, 2(4), 223-230.
- Kaplan, R. M., & Maxwell III, J. T. (1994). *U.S. Patent No. 5,325,091*. Washington, DC: U.S. Patent and Trademark Office.
- Karahanna, E., Straub, D. W., & Chervany, N. L. (1999). Information technology adoption across time: a cross-sectional comparison of pre-adoption and post-adoption beliefs. *MIS quarterly*, 183-213.
- Katawetawaraks, C., & Cheng, L. W. (2011). Online shopper behavior: Influences of online shopping decision. *Asian Journal of Business Research*, 1(2).



- Kaufman-Scarborough, C., & Lindquist, J. D. (2002). E-shopping in a multiple channel environment. *Journal of Consumer Marketing*, 19(4), 333-350.
- Keen, N. & Taylor, S. (2004). Aurora-kinase inhibitors as anticancer agents. *Nature Reviews Cancer*, 4(12), 927-936.
- Kenny, D. A., Kaniskan, B., & McCoach, D. B. (2015). The Performance of RMSEA in Models With Small Degrees of Freedom. *Sociological Methods & Research*, 44(3), 486-507.
- Kent, R. A. (2007). *Marketing Research: Approaches, methods and applications in Europe*. London: Thomson Learning.
- Kerlinger, F. N., & Lee, H. B. (1999). Foundations of behavioral research.
- Khalil, N. (2014). Factors affecting the consumer's attitudes on online shopping in Saudi Arabia. *International Journal of Scientific and Research Publications*, 4(11), 1-8.
- Kidd, S. A., & Kral, M. J. (2005). Practicing Participatory Action Research. *Journal of Counseling Psychology*, 52(2), 187-195.
- Kim, A. J., & Ko, E. (2012). Do social media marketing activities enhance customer equity? An empirical study of luxury fashion brand. *Journal of Business Research*, 65(10), 1480-1486.
- Kim, J. B. (2012). An empirical study on consumer first purchase intention in online shopping: integrating initial trust and TAM. *Electronic Commerce Research*, 12(2), 125-150.
- King, W. & He, J. (2006). A meta-analysis of the technology acceptance model. *Information & Management*, 43(6), 740-755.
- Kinney, T. & Taylor, J. (1991). Marketing research: an applied approach.
- Klein, H. K., & Myers, M. D. (1999). A set of principles for conducting and evaluating interpretive field studies in information systems. *MIS quarterly*, 67-93.
- Kline, R.B. (2011). *Principles and Practice of Structural Equation Modeling* (3rd ed.). New York: The Guilford Press.
- Ko, H., Jung, J., Kim, J., & Shim, S. W. (2004). Cross-cultural differences in perceived risk of online shopping. *Journal of Interactive Advertising*, 4(2), 20-29.
- Koshy, S. (2013). Twitter as marketing tools in the UAE. The University of Wollongong.

- Kourouthanassis, P. E., & Giaglis, G. M. (2008). *Pervasive information systems*. ME Sharpe.
- Koyuncu, C. & Lien, D. (2013). E-commerce and consumer's purchasing behavior. *Applied Economics*, 35, 721-726.
- Kuhlmeier, D., & Knight, G. (2005). Antecedents to internet-based purchasing: a multinational study. *International Marketing Review*, 22(4), 460-473.
- Kura, S. Y. B. (2012). Qualitative and Quantitative Approaches to the Study of Poverty: Taming the Tensions and Appreciating the Complementarities. *The Qualitative Report*, 17(34), 1-19.
- Kwek, C. L., Lau, T. C., & Tan, H. P. (2010). The Effects of Shopping Orientations, Online Trust and Prior Online Purchase Experience toward Customers' Online Purchase Intention . *International Business Research* , 63-75.
- Laroche, M., Habibi, M. R., & Richard, M. O. (2013). To be or not to be in social media: How brand loyalty is affected by social media?. *International Journal of Information Management*, 33(1), 76-82.
- Laroche, M., Yang, Z., McDougall, G. H., & Bergeron, J. (2005). Internet versus bricks-and-mortar retailers: An investigation into intangibility and its consequences. *Journal of retailing*, 81(4), 251-267.
- Laudon, K., & Traver, C. G. (2007). E-Commerce 2007: Business. *Technology*.
- Lee, N., & Lings, I. (2008). *Doing business research: a guide to theory and practice*. Sage.
- Leonardi, P. M., Bailey, D. E., Diniz, E. H., Sholler, D., & Nardi, B. (2016). Multiplex Appropriation in Complex Systems Implementation: The Case of Brazil's Correspondent Banking System. *Mis Quarterly*, 40(2), 461-473.
- Liao, T. H., & Keng, C. J. (2013). Online shopping delivery delay: Finding a psychological recovery strategy by online consumer experiences. *Computers in Human Behavior*, 29(4), 1849-1861.
- Liao, Z., & Cheung, M. T. (2001). Internet-based e-shopping and consumer attitudes: an empirical study. *Information & Management*, 38(5), 299-306.
- Lim, H., & Dubinsky, A. J. (2004). Consumers' perceptions of e-shopping characteristics: an expectancy-value approach. *Journal of Services Marketing*, 18(7), 500-513.

- Lim, K. H., Sia, C. L., Lee, M. K., & Benbasat, I. (2006). Do I trust you online, and if so, will I buy? An empirical study of two trust-building strategies. *Journal of management information systems*, 23(2), 233-266.
- Lim, W. M., & Ting, D. H. (2012). E-shopping: an analysis of the technology acceptance model. *Modern Applied Science*, 6(4), 49.
- Lim, W. M. (2014). Understanding the influence of online flow elements on hedonic and utilitarian online shopping experiences: a case of online group buying. *Journal of Information Systems*, 28(2), 287-306.
- Lim, Y. J., Osman, A., Salahuddin, S. N., Romle, A. R., & Abdullah, S. (2016). Factors Influencing Online Shopping Behavior: The Mediating Role of Purchase Intention. *Procedia Economics and Finance*, 35, 401-410.
- Limayem, M., Khalifa, M., & Frini, A. (2000). What makes consumers buy from Internet? A longitudinal study of online shopping. *IEEE Transactions on Systems, Man, and Cybernetics-Part A: Systems and Humans*, 30(4), 421-432.
- Limbu, Y. B., Wolf, M., & Lunsford, D. (2012). Perceived ethics of online retailers and consumer behavioral intentions: The mediating roles of trust and attitude. *Journal of Research in Interactive Marketing*, 6(2), 133-154.
- Loarie, S. R., Duffy, P. B., Hamilton, H., Asner, G. P., Field, C. B., & Ackerly, D. D. (2009). The velocity of climate change. *Nature*, 462(7276), 1052-1055.
- Loether, H. J., & McTavish, D. G. (1974). *Descriptive statistics for sociologists: An introduction*. Boston: Allyn and Bacon.
- Lohse, G. L., Bellman, S., & Johnson, E. J. (2000). Consumer buying behavior on the Internet: Findings from panel data. *Journal of interactive Marketing*, 14(1), 15-29.
- Lukka, V., & James, P. T. (2014). Attitudes toward Facebook advertising. *Journal of management and Marketing Research*, 14, 1.
- Lunn, R. J., & Suman, M. W. (2002). Experience and trust in online shopping. *The internet in everyday life*, 549-577.
- Lynch, P. D., Kent, R. J. and Srinivasan, S. S., "The Global Internet Shopper: Evidence From Shopping Tasks in Twelve Countries," *Journal of Advertising Research* Vol. 41, No. 3: 15-23, 2001.

- MacArthur, R. L., Wang, Y. H., & Feng, X. (2016). Influence of Age and Education on Nutritional Knowledge and Dietary Choices among Chinese Consumers in Shenyang.
- MacCallum, R. C., Browne, M. W., & Sugawara, H. M. (1996). Power analysis and determination of sample size for covariance structure modeling. *Psychological methods*, 1(2), 130.
- Mackenzie, N., & Knipe, S. (2006). Research dilemmas: Paradigms, methods and methodology. *Issues in educational research*, 16(2), 193-205.
- MacKinnon, D. P. (2008). Introduction to Statistical Mediation Analysis. New York, NY: Lawrence Erlbaum Associates.
- Mahmood, M. A., Bagchi, K., & Ford, T. C. (2004). On-line shopping behavior: Cross-country empirical research. *International Journal of Electronic Commerce*, 9(1), 9-30.
- Maldonado, U. P. T., Khan, G. F., Moon, J., & Rho, J. J. (2009, November). E-learning motivation, students' acceptance/use of educational portal in developing countries: a case study of Peru. In *Computer Sciences and Convergence Information Technology, 2009. ICCIT'09. Fourth International Conference on* (pp. 1431-1441). IEEE.
- Malhotra, N. (2007). Marketing Research- An Applied Orientation. 5<sup>th</sup> edition, NJ: Pearson/Prentice-Hall.
- Malhotra, N. K., & Birks, D. F. (2007). *Marketing research: An applied approach*. Pearson Education.
- Marsh, Herbert W., and Dennis Hocevar. "Application of confirmatory factor analysis to the study of self-concept: First-and higher order factor models and their invariance across groups." *Psychological bulletin* 97.3 (1985): 562.
- Mathwick, C., & Rigdon, E. (2004). Play, flow, and the online search experience. *Journal of consumer research*, 31(2), 324-332.
- Maxwell, J. (1992). Understanding and validity in qualitative research. *Harvard educational review*, 62(3), 279-301.
- Mazaheri, E., Richard, M. O., Laroche, M., & Ueltschy, L. C. (2014). The influence of culture, emotions, intangibility, and atmospheric cues on online behavior. *Journal of Business Research*, 67(3), 253-259.

- McDaniel, C. & Gates, R. (2006). *Marketing Research Essentials – 5<sup>th</sup> Ed.* United State: Thomson Learning.
- McElroy, D., Walsh, C., Markwick, A. J., Cordiner, M. A., Smith, K., & Millar, T. J. (2012). The UMIST database for astrochemistry 2012. *Astronomy & Astrophysics*, 550, A36.
- Mckinney, L. N., "Internet Shopping Orientation Segments: An Exploration of Differences in Consumer Behavior," *Family and Consumer Sciences Research Journal* Vol. 32, No. 4: 408-433, 2004.
- McKnight, D. H., & Chervany, N. L. (2001). What Trust Means in E-Commerce Customer Relationships: An Interdisciplinary Conceptual Typology. *International Journal of Electronic Commerce*, 6(2), 35-59.
- McIver, J., & Carmines, E. G. (1981). *Unidimensional scaling* (No. 24). Sage.
- Meuter, M. L., Bitner, M. J., Ostrom, A. L., & Brown, S. W. (2005). Choosing among alternative service delivery modes: An investigation of customer trial of self-service technologies. *Journal of Marketing*, 69(2), 61-83.
- Mikalef, P., Giannakos, M., & Pateli, A. (2012). Shopping and Word-of-Mouth Intentions on Social Media. *J. Theor. Appl. Electron. Commer. Res.*, 8(1), 5-6.
- Ministry of Communications and Information Technology of Saudi Arabia (2016). Saudi Report and Statistics. Viewed on 10 November 2016. Available at <https://www.saudi.gov.sa/wps/portal/saudi/aboutKingdom/reportsAndStatistics>
- Moe, W. & Fader, P. (2004). Dynamic conversion behavior at e-commerce sites. *Management Science*, Vol. 50, No. 3, pp. 326-335.
- Mokhlis, S. (2009). Relevancy and measurement of religiosity in consumer behavior research. *International Business Research*, 2(3), 75.
- Moon, J. W., & Kim, Y. G. (2001). Extending the TAM for a World-Wide-Web context. *Information & management*, 38(4), 217-230.
- Mortenson, M. J., & Vidgen, R. (2016). A computational literature review of the technology acceptance model. *International Journal of Information Management*, 36(6), 1248-1259.

- Mosteller, J., Donthu, N., & Eroglu, S. (2014). The fluent online shopping experience. *Journal of Business Research*, 67(11), 2486-2493.
- Myers, M. D. (2013). *Qualitative research in business and management*. Sage.
- Nai-Hua, C., & Ya-Wen, H. (2015). ONLINE SHOPPING ORIENTATION AND PURCHASE BEHAVIOR FOR HIGH-TOUCH PRODUCTS. *International Journal of Electronic Commerce Studies*, 187-202.
- Nambisan, P., & Watt, J. H. (2011). Managing customer experiences in online product communities. *Journal of Business Research*, 64(8), 889-895.
- Neilson, (2016). Global Connected Commerce. Viewed on 10 November 2016. Available from <http://www.nielsen.com/content/dam/corporate/us/en/reports-downloads/2016-reports/connected-commerce-report-jan-2016.pdf>
- Neuman, W.L. (2006). *Social Research Methods: Quantitative and Qualitative Methods* (6th ed.). Boston: Pearson Education, Inc.
- Nichols, E., & Childs, J. H. (2009). Respondent Debriefings Conducted by Experts: A Technique for Questionnaire Evaluation. *Field Methods*, 21(2), 115-132.
- Nichols, H. B., Trentham-Dietz, A., Hampton, J. M., Titus-Ernstoff, L., Egan, K. M., Willett, W. C., & Newcomb, P. A. (2006). From menarche to menopause: trends among US women born from 1912 to 1969. *American journal of epidemiology*, 164(10), 1003-1011.
- Ngai, E. W., Moon, K. L. K., Lam, S. S., Chin, E. S., & Tao, S. S. (2015). Social media models, technologies, and applications: an academic review and case study. *Industrial Management & Data Systems*, 115(5), 769-802.
- Ngwenyama, O. Lee (1997). The critical social theory approach to information systems: problems and challenges. *Information systems research: Contemporary approaches and emergent traditions*, pp. 267-280.
- Novak, T. P., Hoffman, D. L., & Yung, Y. F. (2000). Measuring the customer experience in online environments: A structural modeling approach. *Marketing science*, 19(1), 22-42.
- Nunnally, J. C. (1978). *Psychometric theory*. New York: MacGraw-Hill. \_ d.*Intentar embellecer nuestras ciudades y también las*.
- Ogilvie, J., Lindsey, K., Reynolds, K., & Northington, W. M. (2016). Examining Reactive Customer Engagement Strategies in Online Shopping Cart

- Abandonment: A Regulatory Fit Perspective. In *Rediscovering the Essentiality of Marketing* (pp. 755-756). Springer International Publishing.
- Olsson, F.M. (2008). *New Developments in the Psychology of Motivation*. Nova Publishers
- Orlikowski, W. J., & Baroudi, J. J. (1991). Studying information technology in organizations: Research approaches and assumptions. *Information systems research*, 2(1), 1-28.
- Özen, H., & Kodaz, N. (2016). Utilitarian or hedonic? A cross cultural study in online shopping. In *Thriving in a New World Economy* (pp. 234-239). Springer International Publishing.
- Paden, N., & Stell, R. (2000). Using consumer shopping orientations to improve retail Web site design. *Journal of professional services marketing*, 20(2), 73-85.
- Pallant, J. (2007). *SPSS survival manual, 3rd. Edition. McGrath Hill*.
- Park, C., & Jun, J. K. (2003). A cross-cultural comparison of Internet buying behavior: Effects of Internet usage, perceived risks, and innovativeness. *International Marketing Review*, 20(5), 534-553.
- Park, J., Lee, D., & Ahn, J. (2004). Risk-focused e-commerce adoption model: A cross-country study. *Journal of Global Information Technology Management*, 7(2), 6-30.
- Park, J., Yoon, Y. & Lee, B. (2009). The effect of gender and product categories on consumer. Online Information Search. *Advances in Consumer Research*, Vol. 36, pp. 362-366.
- Park, S. Y., Nam, M. W., & Cha, S. B. (2012). University students' behavioral intention to use mobile learning: Evaluating the technology acceptance model. *British Journal of Educational Technology*, 43(4), 592-605.
- Parikh, D. (2011). Customer acceptance of Internet shopping in India: impact of shopping orientations, knowledge and security.
- Parra-López, E., Bulchand-Gidumal, J., Gutiérrez-Taño, D., & Díaz-Armas, R. (2011). Intentions to use social media in organizing and taking vacation trips. *Computers In Human Behavior*, 27(2), 640-654.
- Pavlou, P. A. (2003). Consumer acceptance of electronic commerce: Integrating trust and risk with the technology acceptance model. *International journal of electronic commerce*, 7(3), 101-134.

- Pedhazur, E. J., & Schmelkin, L. P. (1991). Measurement, design, and analysis: An integrated analysis.
- Pence, H. E. (2010). Smartphones, smart objects, and augmented reality. *The Reference Librarian*, 52(1-2), 136-145.
- Perea y Monsuwé, T., Dellaert, B. G., & De Ruyter, K. (2004). What drives consumers to shop online? A literature review. *International journal of service industry management*, 15(1), 102-121.
- Phang, J. Y. (2016). *Consumers' Acceptance towards E-Grocery* (Doctoral dissertation, UTAR).
- “Phil” Klaus, P., & Maklan, S. (2012). EXQ: a multiple-item scale for assessing service experience. *Journal of Service Management*, 23(1), 5-33.
- Phillips, E. A. D. P., & Pugh, D. (2000). How to get a PhD.
- Pickett, K. (2008). Sexist Humor: Local and Systemic Manifestations of Privilege and Disadvantage. ProQuest
- Pinto, J. (2013). Statistical Assessment of Tropical Convection-Permitting Model Simulations Using a Cell-Tracking Algorithm. *Monthly Weather Review*, Vol. 141, No. 2, pp. 557-581.
- Pires, Guilherme, John Stanton, and Andrew Eckford. "Influences on the perceived risk of purchasing online." *Journal of Consumer Behaviour* 4, no. 2 (2004): 118-131.
- Pittaway, L. (2006). Philosophies in entrepreneurship: a focus on economic theories. *Int Jnl Of Ent Behav & Res*, 11(3), 201-221.
- Potter, J. (2003). Review Essay Studying the Standardized Survey as Interaction. *Qualitative Research*, 3(2), 269-278.
- Pratkanis, A. R., Breckler, S. J., & Greenwald, A. G. (2014). *Attitude structure and function*. Psychology Press.
- Punj, G. (2011). Impulse buying and variety seeking: Similarities and differences. *Journal of Business Research*, 64(7), 745-748.
- Queensland Government (2016). Tips of buying online <https://www.qld.gov.au/law/your-rights/consumer-rights-complaints-and-scams/consumer-advice-rights-and-responsibilities/tips-to-become-a-smarter-shopper/tips-for-buying-online/>



- Rahman, M. T. (2016). Customers' Attitude towards Online Shopping: The Case of Bangladesh. *World*, 6(2).
- Rajagopalan, K. K. (2016). Global trends in supply chain management. *ZENITH International Journal of Business Economics & Management Research*, 6(1), 99-112.
- Rajput, N., Kesharwani, S., & Khanna, A. (2012). Dynamics of Female Buying Behaviour: A Study of Branded Apparels in India. *International Journal Of Marketing Studies*, 4(4).
- Ramlugun, V. G., & Jugurnauth, L. (2014). The Scope of Social Media Browsing and Online Shopping for Mauritian E-Retailers: A Study Based on Utilitarian and Hedonic Values. *Review of Integrative Business and Economics Research*, 3(2), 219.
- Rasooli, P. (2006). Knowledge management in call centres. Luleas University of Technology.
- Rezaei, S., Amin, M., & Khairuzzaman Wan Ismail, W. (2014). Online repatronage intention: an empirical study among Malaysian experienced online shoppers. *Intl J Of Retail & Distrib Mgt*, 42(5), 390-421.
- Rietveld, T., & Van Hout, R. (1993). *Statistical techniques for the study of language and language behaviour*. Walter de Gruyter.
- Rogers, E. M. (1995). Diffusion of Innovations: modifications of a model for telecommunications. In *Die Diffusion von Innovationen in der Telekommunikation* (pp. 25-38). Springer Berlin Heidelberg.
- Rohm, A. J., & Swaminathan, V. (2004). A typology of online shoppers based on shopping motivations. *Journal of business research*, 57(7), 748-757.
- Rosenthal, R., & Rosnow, R. L. (1991). *Essentials of behavioral research: Methods and data analysis*. McGraw-Hill Humanities Social.
- Rubin, H. J., & Rubin, I. S. (1995). Qualitative interviewing: The art of hearing data SAGE Publications. *Thousand Oaks, Calif.*
- Ruotsalo, T., Jacucci, G., Myllymäki, P., & Kaski, S. (2015). Interactive intent modeling: Information discovery beyond search. *Communications of the ACM*, 58(1), 86-92.
- Russell, C. & Bobko, P. (1992). Moderated regression analysis and Likert scales: Too coarse for comfort. *Journal Of Applied Psychology*, 77(3), 336-342.

- Sait, S., Al-Tawil, K., & Hussain, S. (2004). E-commerce in Saudi Arabia: Adoption and perspectives. *Australasian Journal of Information Systems*, 12(1).
- Sakarya, S., & Soyer, N. (2013). Cultural differences in online shopping behavior: Turkey and the United Kingdom. *International Journal of Electronic Commerce Studies*, 4(2), 213.
- Saleh, M. A. H. (2016). Social Networks and Customer Relationship Development at the Saudi Telecommunication Service Providers. *International Journal of Marketing Studies*, 8(4), 77.
- Santos, J. (2003). E-service quality: a model of virtual service quality dimensions. *Managing Service Quality: An International Journal*, 13(3), 233-246.
- Saprikis, V. (2013). Suppliers' behavior on the post-adoption stage of business-to-business e-reverse auctions: An empirical study. *Telematics and Informatics*, 30(2), 132-143.
- Saudi Ministry of Commerce (2016). *E-commerce in the kingdom: Breakthrough for the future*, Saudi Ministry of Commerce, Riyadh.
- Saudi Ministry of Foreign Affairs, 2016. Saudi Ministry of Foreign Affairs, Riyadh.
- Saunders, M., & Lewis, P. Thornhill Adrian, 2009. *Research Methods for Business Students*, 5th ed. Harlow, England: Pearson Education Limited.
- Savitskie, K., Royne, M., Persinger, E., Grunhagen, M., & Witte, C. (2007). Norwegian Internet Shopping Sites: An Application & Extension of the Technology Acceptance Model. *Journal Of Global Information Technology Management*, 10(4), 54-73.
- Schafer, J. L., & Graham, J. W. (2002). Missing data: our view of the state of the art. *Psychological methods*, 7(2), 147.
- Schaupp, L. C., & Carter, L. D. (2009). Antecedents to e-file adoption: The US citizen's perspective. *eJournal of Tax Research*, 7(2), 158.
- Schepers, J., & Wetzels, M. (2007). A meta-analysis of the technology acceptance model: Investigating subjective norm and moderation effects. *Information & management*, 44(1), 90-103.

- Schivinski, B., & Dabrowski, D. (2016). The effect of social media communication on consumer perceptions of brands. *Journal of Marketing Communications*, 22(2), 189-214.
- Schindler, R. & Bickart, B. (2012). Perceived helpfulness of online consumer reviews: The role of message content and style. *Journal Of Consumer Behaviour*, 11(3), 234-243.
- Schumacker, R. E., & Lomax, R. G. (2004). *A beginner's guide to structural equation modeling*. Psychology Press.
- Schwarz, N. (1999). Self-reports: How the questions shape the answers. *American Psychologist*, 54(2), 93-105.
- Serazio, M. (2013). Selling (Digital) Millennials: The Social Construction and Technological Bias of a Consumer Generation. *Television & New Media*, 16(7), 599-615.
- Sharma, S., Mukherjee, S., Kumar, A., & Dillon, W. R. (2005). A simulation study to investigate the use of cutoff values for assessing model fit in covariance structure models. *Journal of Business Research*, 58(7), 935-943.
- Shevlin, M. & Miles, J. (1998). Effects of sample size, model specification and factor loadings on the GFI in confirmatory factor analysis. *Personality And Individual Differences*, 25(1), 85-90.
- Shiau, W. L., & Luo, M. M. (2012). Factors affecting online group buying intention and satisfaction: A social exchange theory perspective. *Computers in Human Behavior*, 28(6), 2431-2444.
- Shih, H. (2004). An empirical study on predicting user acceptance of e-shopping on the Web. *Information & Management*, 41(3), 351-368.
- Shim, S., Eastlick, M., Lotz, S., & Warrington, P. (2001). An online prepurchase intentions model. *Journal Of Retailing*, 77(3), 397-416.
- Shuman, M. (2013). *Going local: Creating self-reliant communities in a global age*. Routledge.
- SimilarWeb. (2016) Viewed on 10 October 2016. Available at: <https://www.similarweb.com/>
- Simpson, L., & Lakner, H. B. (1993). Perceived risk and mail order shopping for apparel. *Journal of Consumer Studies & Home Economics*, 17(4), 377-389

- Simonis, P., Dufour, T., & Tenenbaum, H. (2010). Long-term implant survival and success: a 10-16-year follow-up of non-submerged dental implants. *Clinical Oral Implants Research*, 21(7), 772-777.
- Sin, L. Y., Tse, A. C., Yau, O. H., Lee, J. S., & Chow, R. (2002). The effect of relationship marketing orientation on business performance in a service-oriented economy. *Journal of Services marketing*, 16(7), 656-676.
- Sorce, P., Perotti, V., & Widrick, S. (2005). Attitude and age differences in online buying. *International Journal of Retail & Distribution Management*, 33(2), 122-132.
- Stafford, T., Turan, A., & Raisinghani, M. (2004). International and Cross-Cultural Influences on Online Shopping Behavior. *Journal Of Global Information Technology Management*, 7(2), 70-87.
- STATISTA, (2016). Viewed on 10 November 2016. Available from <https://www.statista.com/outlook/243/110/e-commerce/saudi-arabia#>
- Steg, L., Van den Berg, A., E., de Groot, J., I., M., (2012). *Environmental Psychology: An Introduction*. John Wiley & Sons
- Straub, D., Boudreau, M. C., & Gefen, D. (2004). Validation guidelines for IS positivist research. *The Communications of the Association for Information Systems*, 13(1), 63.
- Sulaiman, A., Ng, J., & Mohezar, S. (2008). E-ticketing as a new way of buying tickets: Malaysian perceptions. *Journal of Social Science*, 17(2), 149-157.
- Šumak, B., Polancic, G., & Hericko, M. (2010, February). An empirical study of virtual learning environment adoption using UTAUT. In *Mobile, Hybrid, and On-Line Learning, 2010. ELML'10. Second International Conference on* (pp. 17-22). IEEE.
- Susskind, A. (2006). Electronic Commerce and World Wide Web Apprehensiveness: An Examination of Consumers' Perceptions of the World Wide Web. *Journal Of Computer-Mediated Communication*, 9(3).
- Susskind, A. M. (2004). Electronic commerce and World Wide Web apprehensiveness: An examination of consumers' perceptions of the World Wide Web. *Journal of Computer-Mediated Communication*, Vol. 9, No.3.

- Swaminathan, V., Lepkowska-White, E., & Rao, B. P. (1999). Browsers or buyers in cyberspace? An investigation of factors influencing electronic exchange. *Journal of Computer-Mediated Communication*, 5(2), 0-0.
- Tabachnick, B. G., & Fidell, L. S. (2007). *Experimental designs using ANOVA*. Thomson/Brooks/Cole.
- Talal, A.-M., & Charles, D. (2011). Conceptual framework and managerial implications in the case of Saudi Arabia. *What drives consumers' continuance intention to e-shopping?* , 899-926.
- Taprial, V., & Kanwar, P. (2012). Understanding social media. Varinder Taprial & Priya Kanwar & Ventus Publishing ApS.
- Tauber, E. M. (1972). Why do people shop?. *The Journal of Marketing*, 46-49.
- Taylor, B. J., Kermode, S., & Roberts, K. L. (2006). Research in nursing and health care: Creating evidence for practice.
- Teo, T. (2011). *Technology Acceptance in Education: Research and Issues*. Springer Science & Business Media
- Teo, T., Lim, V., & Lai, R. (1999). Intrinsic and extrinsic motivation in Internet usage. *Omega*, 27(1), 25-37.
- Thakur, R. & Srivastava, M. (2015). A study on the impact of consumer risk perception and innovativeness on online shopping in India. *Intl J Of Retail & Distrib Mgt*, 43(2), 148-166.
- Thamizhvanan, A. & Xavier, M. (2013). Determinants of customers' online purchase intention: an empirical study in India. *Jnl Of Indian Business Res*, 5(1), 17-32.
- Thirumalai, S., & Sinha, K. K. (2005). Customer satisfaction with order fulfillment in retail supply chains: implications of product type in electronic B2C transactions. *Journal of Operations Management*, 23(3), 291-303.
- Tobin, P. K. J. (2006). *The use of stories and storytelling as knowledge sharing practices: a case study in the South African mining industry* (Doctoral dissertation, University of Pretoria, Pretoria).
- Trading Economic, 2016. Saudi Arabia online. Viewed on 10 November 2016. Available from <http://www.tradingeconomics.com/saudi-arabia/population>
- Tull, D. & Hawkins, D. (1997). *Marketing research*. 5<sup>th</sup> Ed. New York: Macmillan.
- Uma Sekaran. (2000). *Research methods for business: A skill-building approach*. John Wiley & Sons.

- Utz, S., Kerkhof, P., & van den Bos, J. (2012). Consumers rule: How consumer reviews influence perceived trustworthiness of online stores. *Electronic Commerce Research And Applications*, 11(1), 49-58.
- Vallerand, R., Pelletier, L., & Koestner, R. (2008). Reflections on self-determination theory. *Canadian Psychology/Psychologie Canadienne*, 49(3), 257-262.
- Van Tubergen, F., Al-Modaf, O. A., Almosaed, N. F., & Al-Ghamdi, M. B. S. (2016). Personal networks in Saudi Arabia: The role of ascribed and achieved characteristics. *Social Networks*, 45, 45-54.
- Van Slyke, C., Comunale, C., & Belanger, F. (2002). Gender differences in perceptions of web-based shopping. *Communications Of The ACM*, 45(8), 82-86.
- Venkatesh, V. & Davis, F. (2000). A Theoretical Extension of the Technology Acceptance Model: Four Longitudinal Field Studies. *Management Science*, 46(2), 186-204.
- Venkatesh, V., Morris, M., & Ackerman, P. (2000). A Longitudinal Field Investigation of Gender Differences in Individual Technology Adoption Decision-Making Processes. *Organizational Behavior And Human Decision Processes*, 83(1), 33-60.
- Venkatesh, V., Thong, J. & Xu, X. (2003). Consumer acceptance and use of information technology: extending the unified theory of acceptance and use of technology. *MIS quarterly*, Vol. 36, No.1, pp.157-178.
- Verhoef, P. & Langerak, F. (2001). Possible determinants of consumers' adoption of electronic grocery shopping in the Netherlands. *Journal Of Retailing And Consumer Services*, 8(5), 275-285.
- Vijayarathy, L. (2002). Product characteristics and Internet shopping intentions. *Internet Research*, 12(5), 411-426.
- Vijayarathy, L. (2003). Shopping Orientations, Product Types and Internet Shopping Intentions. *Electronic Markets*, 13(1), 67-79.
- Visser, E., & Du Preez, R. (2010). Apparel shopping orientation: Two decades of research. *Journal of Family Ecology and Consumer Sciences*. 29, (1).
- Voon, M. L., Lo, M. C., Ngui, K. S., & Ayob, N. B. (2011). The influence of leadership styles on employees' job satisfaction in public sector organizations in Malaysia. *International Journal of Business, Management and Social Sciences*, 2(1), 24-32.

- Wally, E., & Koshy, S. (2014). The use of Instagram as a marketing tool by Emirati female entrepreneurs: an exploratory study.
- Walsham, G. (1993). *Interpreting information systems in organizations*. John Wiley & Sons, Inc..
- Waltz, C., Strickland, O., & Lenz, E. (2005). *Measurement in nursing and health research*. Springer Publishing Company.
- Wan, Y., Nakayama, M., & Sutcliffe, N. (2010). The impact of age and shopping experiences on the classification of search, experience, and credence goods in online shopping. *Information Systems And E-Business Management*, 10(1), 135-148.
- Wang, C., Chen, C. & Jiang, J. (2009). The Impact of Knowledge and Trust on E-Consumers' Online Shopping Activities: An Empirical Study. *Journal of Computer*, Vol. 4, No. 1, pp. 11-19.
- Wang, J., Chung, N., Park, M. & McLaughlin, J. (2012). Understanding online community participation: A technology acceptance perspective. *Communication Research*, Vol.39, No. 6, pp. 781–801.
- Wang, W. T., Wang, Y. S., & Liu, E. R. (2016). The stickiness intention of group-buying websites: The integration of the commitment–trust theory and e-commerce success model. *Information & Management*.
- Weaver, K., & Olson, J. K. (2006). Understanding paradigms used for nursing research. *Journal of advanced nursing*, 53(4), 459-469.
- Webb, J., Murphy, M., Flambaum, V., Dzuba, V., Barrow, J., & Churchill, C. et al. (2001). Further Evidence for Cosmological Evolution of the Fine Structure Constant. *Phys. Rev. Lett.*, 87(9).
- Webb, S. (2002). Intensity-modulated radiation therapy using only jaws and a mask: II. A simplified concept of relocatable single-bixel attenuators. *Physics In Medicine And Biology*, 47(11), 1869-1879.
- Wee, K. N. L., & Ramachandra, R. (2000). Cyberbuying in China, Hong Kong and Singapore: Tracking the who, where, why and what of online buying. *International Journal of Retail & Distribution Management*, 28(7), 307.
- Weenink, D. (2003). Canonical correlation analysis. In *Proceedings of the Institute of Phonetic Sciences of the University of Amsterdam* (Vol. 25, pp. 81-99). University of Amsterdam.

- Weisberg, J., Te'eni, D., & Arman, L. (2011). Past purchase and intention to purchase in e-commerce. *Internet Research*, 21(1), 82-96.
- West, S. G., Finch, J. F., & Curran, P. J. (1995). Structural equation models with nonnormal variables: Problems and remedies.
- Westbrook, R. A., & Black, W. C. (1985). A motivation-based shopper typology. *Journal of retailing*.
- Wilson, J. (2010). *Essentials of Business Research: A Guide to Doing Your Research Project*. SAGE Publications.
- Winter, G. (2000). A comparative discussion of the notion of 'validity' in qualitative and quantitative research. *The qualitative report*, 4(3), 1-14.
- Wolfenbarger, M. & Gilly, M. (2001). Shopping Online for Freedom, Control, and Fun. *California Management Review*, 43(2), 34-55.
- Wortham, J. (2010). Cellphones now used more for data than for calls. *New York Times*, 14.
- Wu, S. I. (2003). The relationship between consumer characteristics and attitude toward online shopping. *Marketing Intelligence & Planning*, 21(1), 37-44.
- Wu, W. Y., & Ke, C. C. (2016). An online shopping behavior model integrating personality traits, perceived risk, and technology acceptance. *Social Behavior and Personality: an international journal*, 44(3), 85-97.
- Wynd, C., Schmidt, B., & Schaefer, M. (2003). Two Quantitative Approaches for Estimating Content Validity. *Western Journal Of Nursing Research*, 25(5), 508-518.
- Xia, L. (2002). Affect as information: the role of affect in consumer online behaviors. *NA-Advances in Consumer Research Volume 29*.
- Yang, Z. and R. T. Peterson., (2004), "Customer perceived value, satisfaction, and loyalty: The role of switching costs", *Psychology & Marketing*, Vol. 21, No. 10, pp. 799.
- Yi, J. L., Abdullah, O., Shahrul, N. S., Abdul, R. R., & Safizal, A. (2016). Factors Influencing Online Shopping Behavior: The Mediating Role of Purchase Intention. *Procedia Economics and Finance* , 401 – 410 .
- Yilmaz, Ö. (2014). The effect of websites on customer preferences related to tourism products within the framework of Technological Acceptance Model (TAM). *IIB International Refereed Academic Social Sciences Journal*, 5(16), 46.



- Yin, R. (2003). Case study research. Design and methods. 3<sup>rd</sup> edition, Thousand Oaks, Sage.
- Yu, C. & Bastin, M. (2010). Hedonic shopping value and impulse buying behavior in transitional economies: A symbiosis in the Mainland China marketplace. *Brand Manag*, 18(2), 105-114.
- Yun, W., Makoto, M. & Norma, S. (2012). The impact of age and shopping experiences on the classification of search, experience, and credence goods in online shopping. *Information Systems & e-Business Management*, Vol. 10, No. 1, p135 – 152.
- Zaki, S. (2013). *Saudi online food delivery market to reach SR820 m. Saudi Gazette*,. Retrieved 8 February 2015, from <http://www.saudigazette.com.sa/index.cfm?method=home.regcon&contentid=20130926181641>
- Zendehdel, M., Paim, L. H., & Delafrooz, N. (2016). The moderating effect of culture on the construct factor of perceived risk towards online shopping behaviour. *Cogent Business & Management*, 3(1), 1223390.
- Zhang, J. H., Xu, Y. J., & Zhang, Z. (2014). E-commerce Discipline Teaching Reform and General Education. In *2014 International Conference on Management Science and Management Innovation (MSMI 2014)*. Atlantis Press.
- Zhou, J. (2003). When the presence of creative coworkers is related to creativity: Role of supervisor close monitoring, developmental feedback, and creative personality. *Journal Of Applied Psychology*, 88(3), 413-422.
- Zhou, L., Dai, L., & Zhang, D. (2007). Online shopping acceptance model-A critical survey of consumer factors in online shopping. *Journal of Electronic Commerce Research*, 8(1), 41.
- Zikmund-Fisher, Brian J., Timothy P. Hofer, Mandi L. Klamerus, and Eve A. Kerr. "First Things First." *The Patient: Patient-Centered Outcomes Research*2, no. 4 (2009): 221-231.

## Appendix 1: PhD Flow Map

	Research Problems	Research Questions	Data sources	Literature	Contributions to knowledge
1. The OSAM in Saudi Arabia	Many studies concerning the e-consumer or shopping online have been conducted in Saudi Arabia, but none have focused specifically on the OSAM, particularly examining trust in the OSAM model.	1-What are the factors that affect the acceptance of online shopping in Saudi Arabia?	Online Survey of NUMBER of people in Saudi Arabia, distributed through WHAT? When will this be collected?  Using a common OSAM questionnaire	OSAM  Online shopping  Online shopping acceptance	This research will show that the OSAM <b>explain</b> user acceptance of e-commerce by examining online shopping behavior differences in Saudi Arabia. In addition, it will add to knowledge of the OSAM variable of trust as having an additional effect on consumer acceptance.
2. The OSAM in Saudi Arabia and social media platform use	Research on measuring social media platform use and online shopping acceptance in Saudi Arabia is rare, especially using the OSAM model	2. How does the use of social media platforms make an impact on the OSAM model?	Online Survey Questions regarding social media platform use and prediction of purchasing through social media	OSAM  Online shopping intention  Social media platform use	This research will contribute to showing the importance of the role that use of social media platforms plays in Saudi Arabia, which will influence the OSAM factors.

## Appendix 2: Ethical Approval

University of  
**Salford**  
MANCHESTER

College of Arts & Social Sciences  
Room 631 Maxwell Building  
The Crescent  
Salford, M5 4WT  
Tel: 0161 295 5876

11 June 2014

Aber Wazzan  
University of Salford

Dear Aber

**Re: Ethical Approval Application – CASS130036**

I am pleased to inform you that based on the information provided, the Research Ethics Panel have no objections on ethical grounds to your project.

Yours sincerely

**Deborah Woodman**  
**On Behalf of CASS Research Ethics Panel**

## **Appendix 3: Questionnaire**

### **3.1 English Questionnaire**

#### **SECTION ONE: Introduction**

Dear Participant,

I am a PhD student in the University of Salford - Salford Business School and I am currently conducting research into develop a conceptual model of online shopping acceptance OSAM in Saudi Arabia which is a reference tool used to describe consumer behaviour in terms of acceptance of online shopping in Saudi Arabia and it will show the roles that social media platforms provide to the potential customer. This research will form part of my PhD dissertation and your help in completing this questionnaire would be extremely important to me. Responses this survey are considered confidential and therefore I can assure you that the results from this study will not be released in its raw format. In participating in this survey, the participant recognizes that only statistical analysis of the collective data from all participants will be reported in the thesis. Also, there will be no commercial use of the results from the survey. Thus, there are anonymous and no names or other personal information will be revealed in accordance with the standards of Research Ethics governing the University of Salford students and staff. I very much appreciate you completing ALL the questions, as incomplete questions means that your valuable contribution cannot be used.

If you need to contact me please feel free to do so at:

a.a.wazzan@edu.salford.ac.uk

If you are under 18 please do not proceed with this survey.

Are you a current resident of Kingdom of Saudi Arabia? (Please note that this survey is for residents only)?

Yes

No

## **SECTION TWO: Internet Experience:**

**For how long have you been using the Internet?**

- Less than 1 year
- 1–2years
- 2–3years
- 3–4years
- 4- 5 years
- More than 5 years

**In a typical day, roughly how much time do you spend using the Internet?**

- 0- 10 minutes
- 11 – 30 minutes
- 31 minutes - 1 Hours
- 1- 2 Hours
- 2- 3 Hours
- 3- 4 hours and more
- More than 4 hours

## **SECTION THREE: Social Network**

**Do you have any social network accounts (e.g. Facebook, Google+, etc.)? (If you answer No, please note that you will automatically transferred into Fourth Section).**

- YES
- N o

**Which social networking website do you most often use? (Please select all that apply.)**

- Blogger
- Facebook
- Google
- Instagram
- Kick
- Twitter
- YouTube
- Other (please specify)

**In a typical day, about how much time do you spend using social networking websites?**

- 0- 10 minutes
- 11 – 30 minutes
- 31 minutes - 1 Hours
- 1- 2 Hours
- 2- 3 Hours
- 3- 4 hours and more
- More than 4 hours

**How often do you log into social media networks (e.g. Facebook, Google+, etc.)?**

- Less than a few times a month
- A few times a month

- A few times a week
- About once a day
- More than once a day
- More than one a hour
- Always on contacting with smartphone

**Which social media websites have you used to shop or make decisions on regarding online shopping?**

- Blogger
- Facebook
- Google
- Instagram
- Kick
- Twitter
- YouTube
- Other (please specify)

**Please state how much you agree with the following statements:**

Strongly disagree Disagree Some what disagree Neutral Some what agree Agree  
Strongly agree

- Social Media provide a wonderful means in order to find products or services online
- I use Social Media to go through product or services on company hosted pages when

I am online

- I will continue to browse through products and services online via Social Media websites in the future

#### **SECTION FOUR: Online Shopping Experience**

**Have you ever used online shopping in Saudi Arabia? ( If you say NO you will automatically transferred to the next section)**

- YES

- NO

**How often do you buy products or services online in Saudi Arabia?**

- Extremely often

- Quite often

- Moderately often

- Slightly often

- Not at all often

**How many approximately items have you purchased through Internet shopping for the last 12 months?**

- 1-2

- 3-5

- 6-10

- 11-20

- 21 and above

**Regarding costs, how much have you spent on personal online purchases for the last 12 months?**



- 0 – 250 SR
- 251-500 SR
- 501- 2,000 SR
- 2,001 – 5,000 SR
- 5,001 - 7,500 SR
- 7501- 10,000 SR
- SR 10,001 and more

**In which of these categories do your personal online purchases fit in the past 12 months? (Please select all that apply.)**

- Books
- Clothing/accessories/Shoes
- Airline reservations
- Electronics/Mobile phones
- Videos/ DVD/ Games
- Other (please specify)

**Please state how much you agree with the following statements:**

Strongly disagree Disagree Some what disagree Neutral Some what agree Agree  
Strongly agree

- I feel comfortable of using the social media sites to purchase online
- I feel that the social media sites is easy to use when I purchase online
- I feel competent of using the social media sites when I it comes to online purchasing
- I have experienced when it comes to online shopping via social media websites

## **SECTION FIVE: Online Shopping Intention**

Strongly disagree Disagree Some what disagree Neutral Some what agree Agree  
Strongly agree

- When I need to buy a particular product or service, I would intend to search for a social media which has the product or service.
- I intend to buy products or services, I see advertised on Social Media
- I intend to purchase online through social media sites in the near future
- I like to shop from home (for example, using mail-order catalogues, the TV or the Internet)
- I shop from online because I cannot find what I want in local stores Shopping online is more convenient than going to the store
- I can save a lot of money by online shopping
- I like to have a great deal of information on social media sites before I buy products or services online

## **SECTION SIX: Shopping Motivation**

Strongly disagree Disagree Some what disagree Neutral Some what agree Agree  
Strongly agree

- Social Media websites are a convenient medium since I can find products or services

whenever I want to

- It is convenient to find products or services through Social Media since I can do so in the comfort of my own space

- Through Social Media I can find products or services in accordance with my schedule

- Social Media provide me with quick access to large volumes of information about products or services

- I can collect useful information about a products or services I want through Social

- Comments by other users of Social Media websites help in giving feedback about a products or services advertised

- Social Media help me find more products or services that I was unfamiliar with before

- I can find a wide selection of products or services in one website through Social Media

- With Social Media I can browse through a large array of products or services

- I find that through information from my profile on Social Media websites, I am presented with products or services advertisements that are more compatible to my likings

- Products or services presented to me on Social Media platforms are customized to my needs

Products or services recommendations on Social Media websites make me feel as an important customer

Social Media provide a great platform in order to exchange information with my friends regarding products or services

- Through Social Media I can be informed effectively share my experience of a newly purchased products or services with others.

- I can make a new friend with other shoppers through Social Media websites
- I find products or services through Social Media to be stimulating
- To me, found products or services via Social Media websites is an adventure
- I get drawn in to a world of my own when found products or services on Social Media Platforms
- When found products or services on Social Media websites I feel I am in control
- Through Social Media websites I feel that I have a good understanding on the products or services features which I found it
- Social Media enable me to control my products or services browsing

**SECTION SEVEN: Demographic**

What is your gender?

- 1- Male**
- 2- Female**

Which category below includes your age?

- 1- 18-24
- 2- 25-29
- 3- 30-35
- 4- 36 or older

What is your approximate average income per month?

- 1- SR 2,000 and below
- 2- SR 2,001- 5,000
- 3- SR 5,001 - 8,000
- 4- SR 8,001 - 12,000
- 12,001 and up

What is the highest level of education you have completed?

- 1- Did not attend school
- 2- Primary school

- 3- Elementary school
- 4- Secondary School
- 5- Bachelor degree
- 6- Master Degree
- 7- PhD Degree and above

## Arabic Questionnaire

### المقدمة

عزيزي المشارك/المشاركة:  
السلام عليكم ورحمة الله وبركاته اما بعد

انا طالبة دكتوراه من جامعة سالفورد قسم التسويق ببريطانيا ، اقوم حاليا باجراء دراسه بحثية في تطوير نموذج قبول التسوق الالكتروني في المملكة العربية السعودية حيث ان هذا النموذج هو اداة قياس مرجعية لسلوك المستهلكين في قبول التسوق الالكتروني ودور شبكات التواصل الاجتماعية في زيادة هذا القبول.

ان هذا البحث هو جزء من رسالة دكتوراه، لذا فان مساعدتكم في استكمال هذا الاستطلاع سوف يكون في غاية الاهمية بالنسبة لي. تعتبر نتائج هذه الدراسة سرية للغاية بالتالي يمكنني ان اؤكد بان مخرجات هذا الاستطلاع لن يتم الافصاح عنها بأي شكل من الاشكال حيث ان الهدف الاساسي خلف هذا الاستطلاع هو التحليل الاحصائي فقط دون اي غرض تجاري، بالتالي ووفقا للمعايير التي تحكم اخلاقيات البحوث الخاصة بطلاب وموظفي جامعة سالفورد، فإنه لن يتم الكشف عن أي اسما ء او معلومات شخصية.

اتقدم مسبقا بكامل الشكر والتقدير لكل من شارك ومنحني بعضا من وقته لانهاء كافة الاسئلة.

تنويه:

ان هذا الاستطلاع لن يكون ذو فائدة مالم نكتمل الاجابة على جميع اسئلته، لذا ومن هذا المنطلق، فاني ارجو من كل مشترك الاجابة عليها جميعا  
أعدّ هذا الاستبيان لمن هم فوق سن الثامنة عشرة فقط. لذا ارجو شاكرا لمن هم خارج نطاق هذه الفئة العمرية بعدم تعبئته

إذا كنت بحاجة إلى استفسار فلا تتردد بالاتصال بي على الايميل التالي :

[a.a.wazzan@edu.salford.ac.uk](mailto:a.a.wazzan@edu.salford.ac.uk)

هل تقيم او تقيمي حاليا في المملكة العربية السعودية؟

هذا الاستبيان مخصص فقط للمواطنين والمقيمين في السعودية

- نعم
- لا

الجزء الثاني : خبرات استخدام الانترنت

منذ متى وأنت تستخدم الانترنت ؟

- أقل من سنة واحدة
- من سنة إلى سنتين

- من ثلاث سنوات الى ٤ سنوات
- من ٥ سنوات الى ٦ سنوات
- أكثر من ٦ سنوات

في يومك العادي، كم معدل استخدامك الانترنت ؟

- من صفر - ١٠ دقائق
- من ١١ دقيقة الى ٣٠ دقيقة
- ٣١ دقيقة الى ساعه
- من ساعه الى ساعتين
- من ساعتين الى ثلاث ساعات
- من ثلاث الى اربع ساعات
- أكثر من اربع ساعات

### الجزء الثالث : مواقع التواصل الاجتماعي

هل لديك حساب على اي شبكة من شبكات التواصل الاجتماعية (مثل الفيسبوك ، تويتر ، الخ ) ؟  
(اذا كانت اجابتك لا فسوف تنتقل الى القسم الرابع من الاستبيان)

- نعم
- لا

أي موقع من شبكات التواصل الاجتماعي تستخدم في معظم الأحيان ؟ (يرجى اختيار كل الحسابات التي لديك)

- بلوقر
- فيسبوك
- جوجل بلس
- انيستجرام
- كيك
- تويتر
- يوتيوب
- اخرى

في اليوم العادي ، كم من الوقت تقريبا تقضي على مواقع التواصل الاجتماعي ؟

- من صفر - ١٠ دقائق
- من ١١ دقيقة الى ٣٠ دقيقة
- ٣١ دقيقة الى ساعه
- من ساعه الى ساعتين
- من ساعتين الى ثلاث ساعات
- من ثلاث الى اربع ساعات
- أكثر من اربع ساعات

ما هو معدل دخولك على شبكات التواصل الاجتماعي (مثل الفيسبوك ، تويتر ، الخ ) غالبا ؟

- أقل من بضع مرات في الشهر
- بضع مرات في الشهر
- بضع مرات في الأسبوع
- مرة واحدة في اليوم
- أكثر من مرة في اليوم
- أكثر من مرة في الساعه
- دائما على اتصال مع الهاتف الذكي

أي موقع من مواقع التواصل الاجتماعي تستخدمها في شراء المنتجات او اتخاذ القرار بالنسبه للشراء الالكتروني ؟

- بلوقر
- فيسبوك
- جوجل بلس
- انيستجرام
- كيك
- تويتر
- يوتيوب
- اخرى

يهيئنا التعرف على مدى اتفاقك في كل من العبارات التاليه:

لا أوافق بشده لا أوافق بعض الأحيان لا أوافق لا أعلم بعض الأحيان أوافق أوافق و  
بشده

- وسائل التواصل الاجتماعي توفر وسيلة رائعة للبحث عن المنتجات أو الخدمات عبر الإنترنت
- يمكنني من خلال وسائل التواصل الاجتماعي التعرف على منتجات أو خدمات لشركة معينة من خلا ل زيارة استضافة صفحتهم في مواقع التواصل الاجتماعي
- سوف استمر في التعرف على المنتجات والخدمات الالكترونيه من خلال مواقع التواصل الاجتماعي في المستقبل

**الجزء الرابع: مدى استخدامك للشراء الالكتروني**

هل سبق لك الشراء عبر الإنترنت في المملكة العربية السعودية؟  
( اذا كانت اجابتك لا فسوق تنتقل الى الجزء التالي من الاستبيان )

- نعم
- لا



ماهو غالبا معدل شراء المنتجات أو الخدمات عبر الإنترنت في المملكة العربية السعودية ؟

- في غالب الاحيان
- في كثير من الاحيان
- الى حد ما
- في بعض الاحيان
- لا على الاطلاق

كم عدد المنتجات تقريبا قمت بشرائها خلال ال ١٢ شهر الماضيه ؟

- ٢-١
- ٥-٣
- ١٠-٦
- ٢٠-١١
- ٢١ أو أكثر

بالسنيه للتكلفة، كم معدل انفاقك بالريال السعودي في الشراء عبر الإنترنت للأغراض الشخصية في خلال الأشهر ال ١٢ الماضية ؟

- من صفر إلى ٢٥٠ ريال
- من ٢٥١ إلى ٥٠٠ ريال
- من ٥٠١ إلى ٢,٠٠٠ ريال
- من ٢,٠٠١ إلى ٥,٠٠٠ ريال
- من ٥,٠٠١ إلى ٧,٥٠٠ ريال
- من ٧,٥٠١ الى ١٠,٠٠٠ ريال
- اكثر من ١٠,٠٠٠ ريال

خلال الأشهر ال ١٢ الماضية ، أي من الفئات التالية تدرج الأغراض الشخصية التي قمت بشرائها عبر الانترنت ؟

- كتب
- ملابس / اكسسوارات / احذية
- تذاكر الطيران
- الجوالات او الاجهزه الالكترونيه
- افلام / دي في دي / العاب الكترونية
- أخرى

يهيئنا التعرف على مدى اتفاقك في كل من العبارات التالية:

لا أوافق بشده لا أوافق بعض الأحيان لا أوافق لا أعلم بعض الأحيان أوافق أوافق وأوافق و بشده

- أشعر بالراحة لاستخدام مواقع التواصل الاجتماعي في الشراء الالكتروني
- أشعر أن موقع التواصل الاجتماعي سهل عملية الشراء الالكتروني

- لدي خبرة في الشراء الالكتروني وذلك عن طريق استخدام مواقع التواصل الاجتماعي
- أشعر بأنني متخصص في استخدام مواقع التواصل الاجتماعي عند الشراء الالكتروني

#### القسم الخامس : نية التسوق الالكتروني

يهيئنا التعرف على مدى اتفاقك في كل من العبارات التالية:

لا أوافق بشده لا أوافق بعض الأحيان لا أوافق لا أعلم بعض الأحيان أوافق أوافق وأوافق و  
بشده

- عندما يكون لدي رغبة في شراء منتج معين أو خدمة معينة، أود أن بحث عنها من خلال وسائل التوا  
صل الاجتماعي

- أنوي دائما شراء المنتجات او الخدمات التي اجد اعلانها في مواقع التواصل الاجتماعي
- أنوي الشراء عبر الإنترنت من خلال مواقع وسائل الاعلام الاجتماعية في المستقبل القريب
- (أود أن تسوق من المنزل أكثر من التسوق العادي (على سبيل المثال، وذلك عن طريق وسائل التوا  
صل الاجتماعي والمواقع الالكترونية

- أفوم بالتسوق الالكتروني لأنني لم أجد المنتج أو الخدمه في المتاجر المحلية
- التسوق الالكتروني أكثر ملائمة من الذهاب الى المتجر
- يمكنني التوفير الكثير من المال من خلال التسوق الالكتروني
- أحب أن يكون لدي كثير من المعلومات عن طريق مواقع التواصل الاجتماعي قبل أن شراء منتجات أ  
و خدمات عبر الانترنت

#### القسم السادس : دوافع التسوق الالكتروني

يهيئنا التعرف على مدى اتفاقك في كل من العبارات التالية:

لا أوافق بشده لا أوافق بعض الأحيان لا أوافق لا أعلم بعض الأحيان أوافق أوافق وأوافق و  
بشده

- مواقع التواصل الاجتماعي هي وسيلة مناسبة لانها تمكنني العثور على منتجات أو خدمات
- عمليه البحث عن منتجات او خدمات عبر مواقع التواصل الاجتماعي في أوقات فراغي تعتبر مريحة
- من خلال مواقع التواصل الاجتماعي فإنه يمكنني البحث عن منتجات أخدمات بما يتوافق مع جدولتي
- وسائل التواصل الاجتماعي توفر لي معلومات مفصلة عن منتجات او خدمات
- يمكنني جمع معلومات مفيدة حول منتجات أو خدمات أريدها من خلال مواقع وسائل التواصل الاجتماعي  
عي

- تعليقات المستخدمين الآخرين للمواقع التواصل الاجتماعي تساعدني في الحصول على المعرفة ع  
ن المنتجات أو الخدمات المعلن عنها
- وسائل التواصل الاجتماعي تساعدني في العثور على المزيد من المنتجات أو الخدمات غير مألوفه بال  
نسبي لي

- يمكنني العثور على مجموعة واسعة من المنتجات أو الخدمات في موقع واحد من خلال وسائل التوا  
صل الاجتماعي

- من خلال وسائل التواصل الاجتماعي يمكنني تصفح مجموعه كبيره من المنتجات والخدمات
- أجد أنه من خلال المعلومات في ملفي الشخصي على مواقع وسائل التواصل الاجتماعي ، أنني أقدم اعلان عن منتجات أو خدمات تتلاءم ميولي
- من خلال التواصل الاجتماعي يمكنني الاطلاع على مجموعة كبير من المنتجات أو الخدمات
- التوصيات علي المنتجات والخدمات في مواقع التواصل الاجتماعي تجعلني اشعر انني عميل مهم
- توفر وسائل التواصل الاجتماعي منصة كبيرة لتبادل المعلومات مع أصدقائي حول منتجات او الخدمتا
- من خلال وسائل التواصل الاجتماعي يمكنني أن أنشر عن تجربتي لمنتجات أو خدمات تم شراؤها حد
- يثا مع الآخرين
- يمكنني التعرف على أصدقاء جدد من المتسوقين من خلال مواقع التواصل الاجتماعي
- أجد بعض المنتجات والخدمات الموجوده في مواقع التواصل الاجتماعي مثيره
- بالنسبة لي، وجود المنتجات أو الخدمات عبر مواقع التواصل الاجتماعي هي مغامرة
- أشعر بالسعادة عندما اجد المنتجات او الخدمات في مواقع التواصل الاجتماعي
- عندما أجد منتجات أو خدمات معينه في مواقع التواصل الاجتماعي، اشعر بالسيطره
- من خلال مواقع التواصل الاجتماعي أشعر أن لدي فهم جيد على مميزات منتجات أو خدمات قد وجدتها من قبل
- وسائل التواصل الاجتماعي تتيح لي السيطرة على تصفح المنتجات أو الخدمات

#### القسم السابع: المعلومات الشخصية

##### الجنس

- ذكر
- أنثى

##### العمر

- من ١٨ الى ٢٤
- ٢٥ الى ٢٩
- ٣٥ الى ٣٥
- ٣٦ وما فوق

##### متوسط الدخل الشهري بالريال السعودي

- ٢٠٠٠ ريال أو أقل
- ٢٠٠١ الى ٥٠٠٠
- ٥٠٠١ الى ٨٠٠٠
- ٨٠٠١ الى ١٢٠٠٠
- ١٢٠٠١ وما فوق

##### مستوى التعليم

- لم التحق بالمدرسه
- شهاده الابتدائي
- شهاده المتوسطه
- شهاده الثانويه
- شهاده البكالوريس
- شهاده الماجستير
- شهاده الدكتوراه ومافوق

### Appendix 4: Regression Weights: (Group number 1 - Default model)

				Estimate	C.R.	P
OS1_1	<---	OS	.821			
OS2_1	<---	OS	.712	10.987	<.001	
OE1_1	<---	OE	.907			
OE2_1	<---	OE	.753	10.727	<.001	
SM1_1	<---	SM	.988			
SM2_1	<---	SM	.988	47.481	<.001	
CO2_1	<---	CO	.865			
CO3_1	<---	CO	.904	24.612	<.001	
IA1_1	<---	IA	.852			
IA2_1	<---	IA	.906	24.234	<.001	
PS1_1	<---	PS	.881			
PS2_1	<---	PS	.897	26.202	<.001	
PS3_1	<---	PS	.924	28.017	<.001	
TD2_1	<---	TD	.857	24.267	<.001	
TD1_1	<---	TD	.911			
AD3_1	<---	AD	.671	7.418	<.001	

AD1_1	<---	AD	.819		
AS3_1	<---	AS	.863	17.553	<.001
AS2_1	<---	AS	.863	17.540	<.001
AS1_1	<---	AS	.752		
OSI2_1	<---	OSI	.760		
OSI3_1	<---	OSI	.795	13.336	<.001
IA3_1	<---	IA	.787	19.060	<.001
SO3_1	<---	SO	.801	9.601	<.001
SO5_1	<---	SO	.743		
CA3_1	<---	CA	.775		
CA2_1	<---	CA	.913	19.459	<.001
CA1_1	<---	CA	.725	14.959	<.001
S2_1	<---	S	.716		
S1_1	<---	S	.804	4.219	<.001